

SNAPPER TRACTOR

REAR PTO ROTARY TILLER

36" - #6-0373

42" - #6-0374

48" - #6-0375

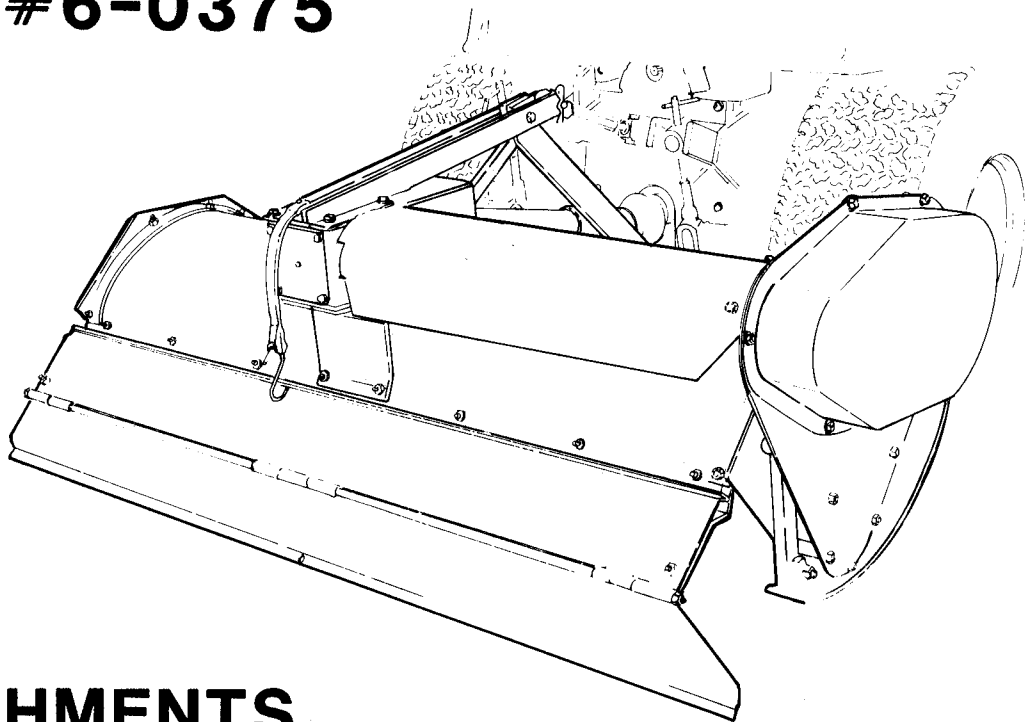

ATTACHMENTS

IT IS THE POLICY OF McDONOUGH POWER EQUIPMENT TO IMPROVE ITS PRODUCTS WHENEVER IT IS POSSIBLE AND PRACTICAL TO DO SO. WE RESERVE THE RIGHT TO MAKE CHANGES OR ADD IMPROVEMENTS AT ANY TIME WITHOUT INCURRING ANY OBLIGATION TO MAKE SUCH CHANGES ON PRODUCTS MANUFACTURED PREVIOUSLY.

36" TILLER INDEX

ATTACHMENT #6-0373

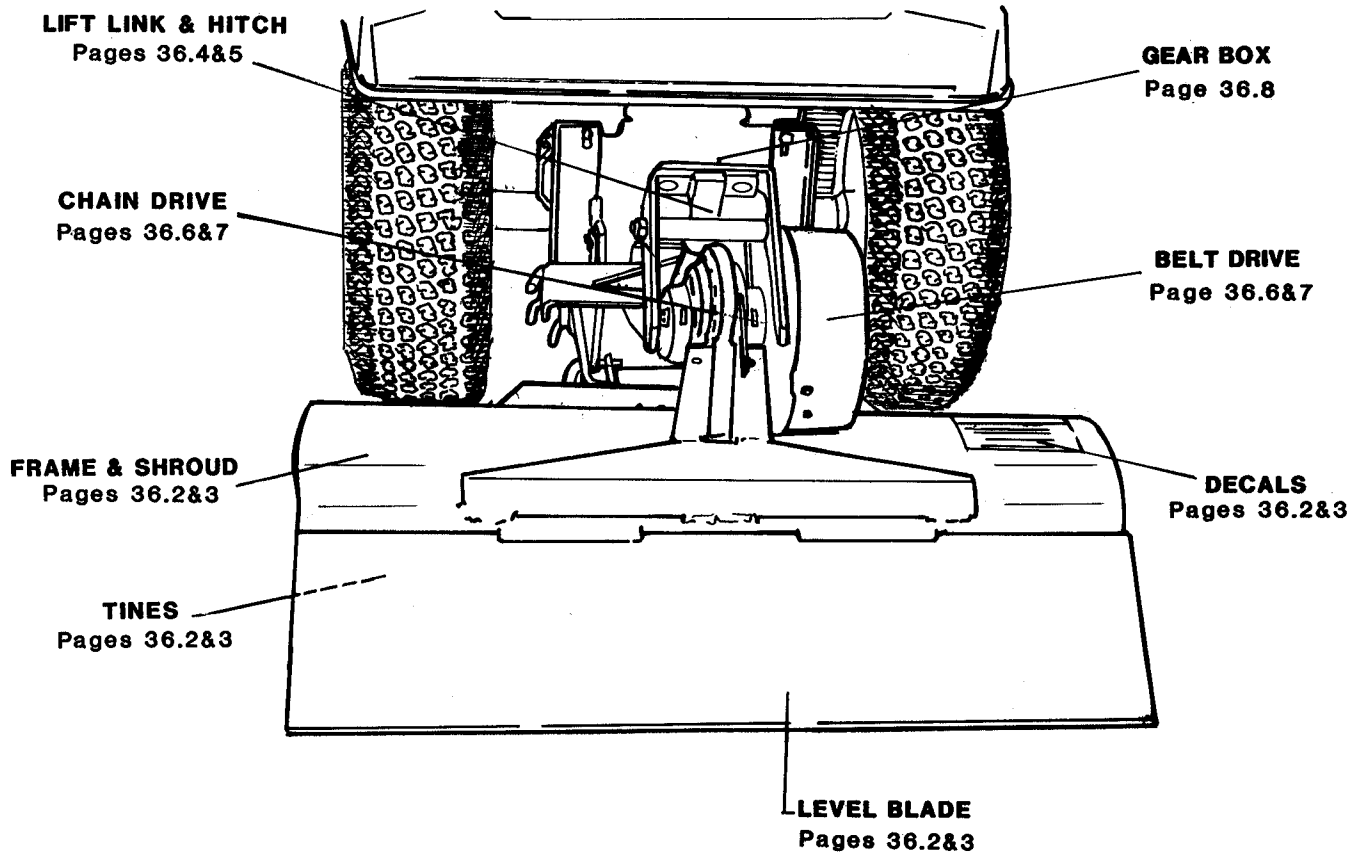

36" GENERAL SPECIFICATIONS

OVERALL WIDTH	-----	38 INCHES
WEIGHT (APPROXIAMTE)	-----	205 LBS.
SHIPPING WEIGHT	-----	230 LBS.
TILLING WIDTH	-----	36 INCHES
TILLER TIPS (NUMBER)	-----	20
TILLING DEPTH (MAXIMUM)	-----	8 INCHES
TINE MATERIAL	-----	HIGH CARBON, HEAT TREATED STEEL
TINE RETAINING BOLT TORQUE	-----	50 to 55 FT. LBS.

FRAME, SHROUD, TINES

36" TILLER

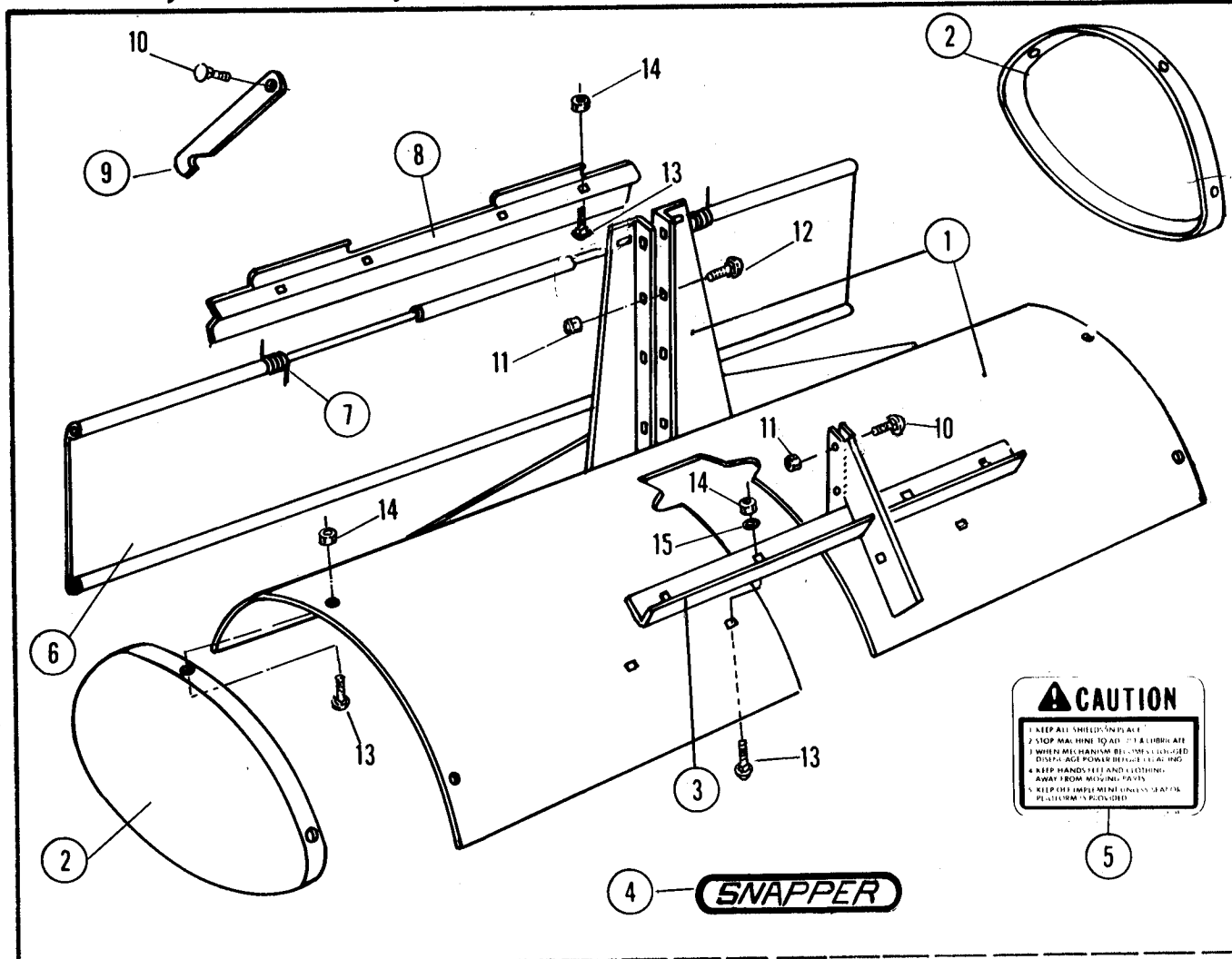

TINES

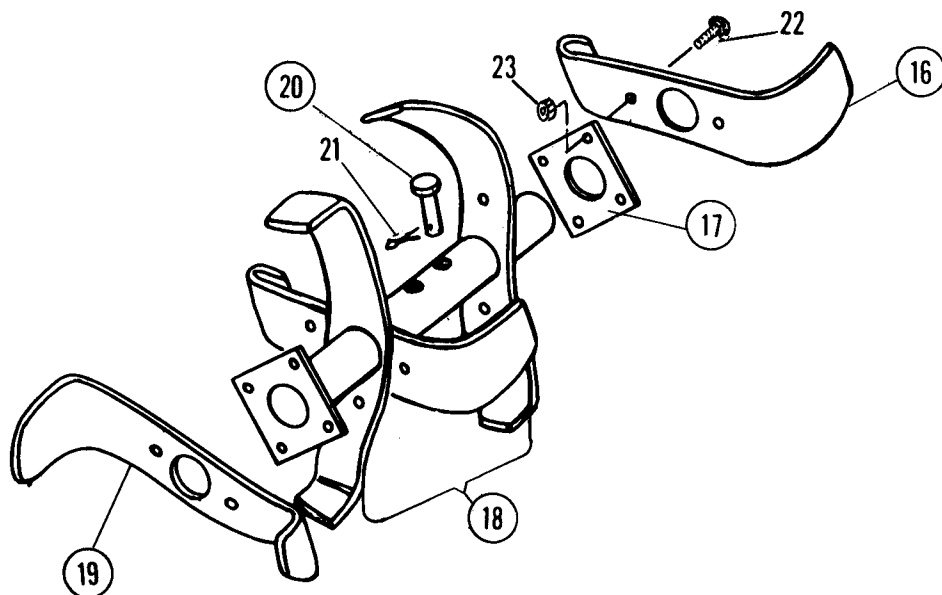

36" TILLER

FRAME, SHROUD, TINES

ITEM	PART NO.	DESCRIPTION
1	1-3799	SHROUD ASSEMBLY, 36" TILLER
2	1-3095	COVER, SHROUD END (SAME BOTH SIDES)
3	1-3798	BRACE, SHROUD
4	1-9668	DECAL, SNAPPER
5	1-8443	DECAL, CAUTION
6	1-3199	LEVEL BLADE
7	1-3955	SPRING, TENSION (2)
8	1-3094	HINGE PLATE
9	1-3801	STRAP, BLADE LOCKING
10	9-0496	BOLT, 1/4-20 x 1 CARRIAGE
11	9-0761	LOCKNUT, 1/4-20 HEX
12	9-0074	BOLT, 1/4-20 x 3/4 CARRIAGE
13	9-0731	BOLT, 5/16-18 x 1/2 CARRIAGE
14	9-0194	LOCKNUT, 5/16-18 HEX
15	9-0692	WASHER, 5/16 PLAIN
16	1-3097	TINE, RIGHT HAND
17	1-3096	PLATE, TINE ATTACHMENT
18	1-3220	TINE ASSEMBLY - RIGHT HAND
-	1-3221	TINE ASSEMBLY - LEFT HAND
19	1-3098	TINE, LEFT HAND
20	1-3100	PIN, TINE SHEAR (4)
21	9-0041	PIN, 1/8 x 1 COTTER (4)
22	9-0762	BOLT, 7/16-20 x 1 HEX HEAD
23	9-0739	LOCKNUT, 7/16 - 20 HEX

UPPER HITCH, ADJUSTER

36" TILLER

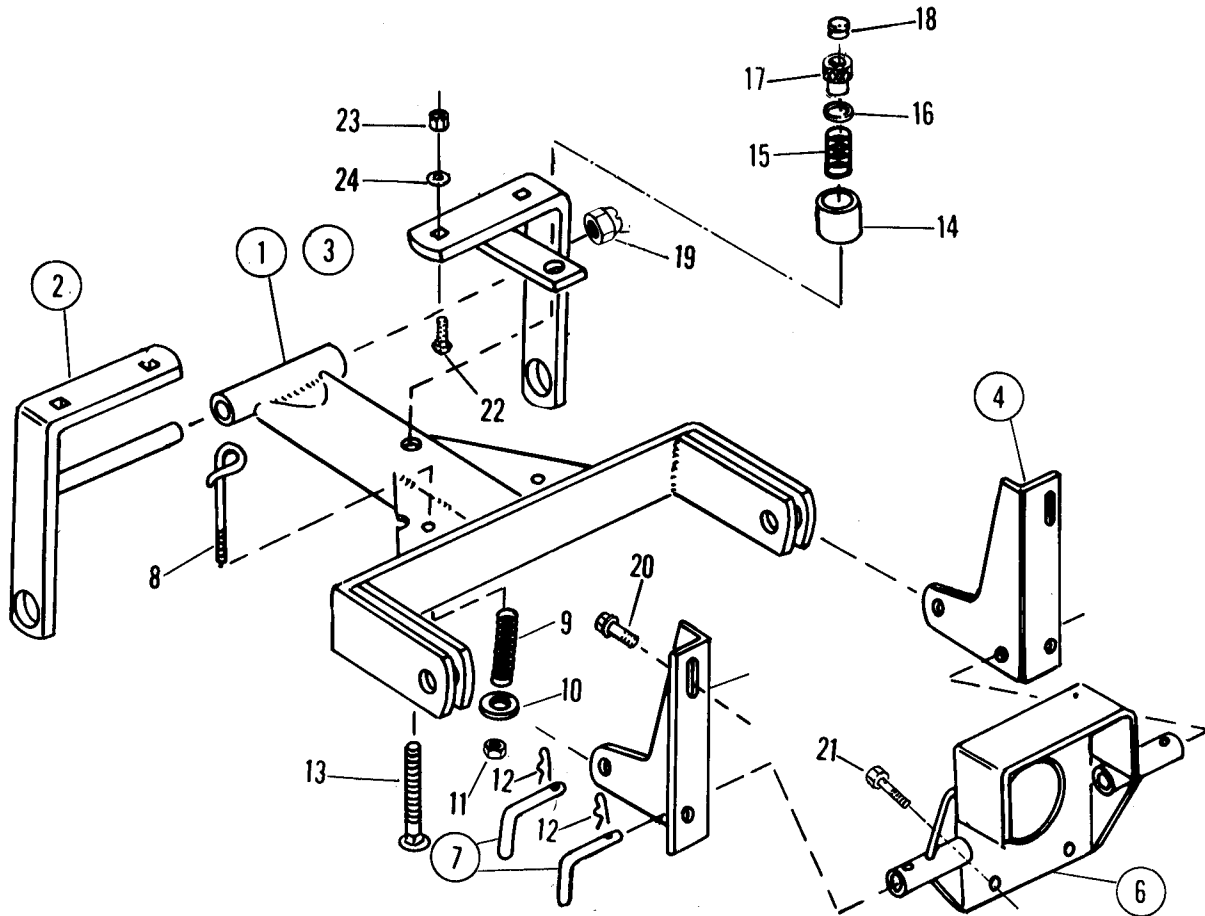

ITEM	PART NO.	DESCRIPTION
1	1-3192	LINK, UPPER HITCH
2	1-3193	BRACKET, RIGHT HAND
3	1-3194	BRACKET, LEFT HAND
4	1-3186	BRACKET, HITCH MOUNT - RIGHT HAND
5	1-3187	BRACKET, HITCH MOUNT - LEFT HAND
6	1-3190	MOUNT, GEAR BOX
7	1-3191	L-PIN, SHORT
8	1-3202	ROD, LOCK
9	1-3203	SPRING, LOCK ROD
10	9-0598	WASHER, SPECIAL
11	9-0761	LOCKNUT, 1/4 HEX
12	1-2867	PIN, 1/8 x 1-7/8 COTTER
13	9-0763	BOLT, SPECIAL CARRIAGE
14	1-3196	TUBE, TENSION LIMIT
15	1-3197	SPRING, BELT TENSION
16	9-0600	WASHER, SPECIAL WIDE RIM
17	1-3960	KNOB, BELT TENSION TORQUE
18	1-3984	GROMMET
19	9-0755	LOCKNUT, 5/8 HEX
20	9-0582	BOLT, HEX FLANGE 3/8 x 1
21	9-0587	BOLT, 3/8-16 x 1-1/4 HEX (4)
22	9-0759	BOLT, 1/2 x 1-1/4 CARRIAGE (2)
23	9-0706	NUT, 1/2-13 HEX LOCK (2)
24	9-0705	WASHER, 1/2 PLAIN (2)

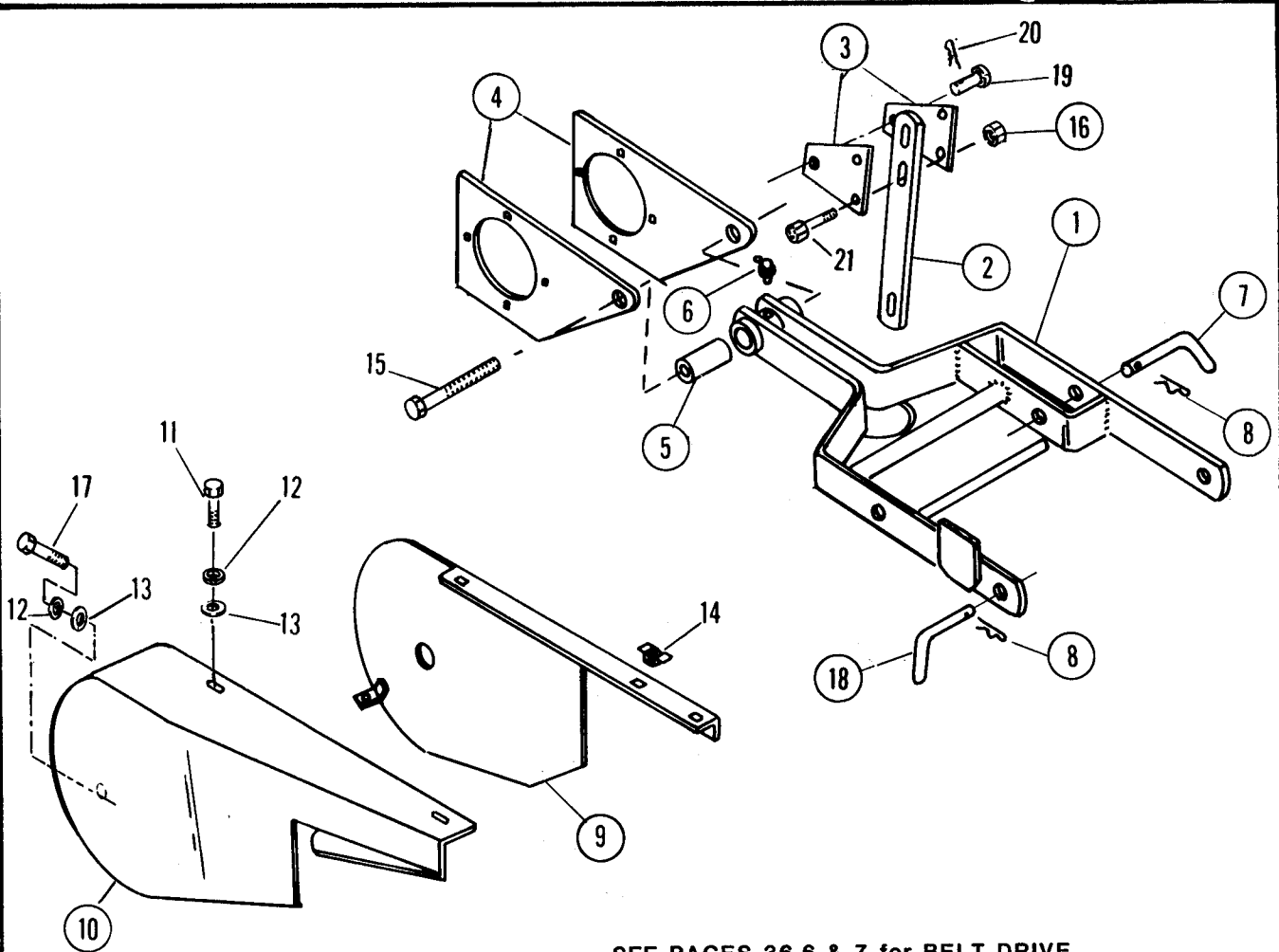

ITEM	PART NO.	DESCRIPTION
1	1-3188	LINK, LOWER LIFT
2	1-3222	STRAP, BAR LIFT
3	1-3223	PLATE, LIFT STRAP (2)
4	1-3092	PLATE, ATTACHING (2)
5	1-3189	BEARING, TUBE
6	1-3066	FITTING, LUBE
7	1-3224	L-PIN, LONG (2)
8	1-2867	PIN, COTTER HAIR 5/32 x 1-13/16
9	1-3200	SHIELD, BELT INNER
10	1-3201	SHIELD, BELT OUTER
11	9-0206	BOLT, 5/16 x 3/4 HEX HEAD
12	9-0187	LOCKWASHER, 5/16
13	9-0692	WASHER, 5/16 PLAIN
14	1-3254	NUT, SPEED GRIP
15	9-0656	BOLT, 1/2 x 4 HEX HEAD
16	9-0706	LOCKNUT, 1/2 HEX
17	9-0203	BOLT, 5/16 x 1/2 HEX HEAD
18	1-3191	L-PIN, SHORT (2)
19	1-3226	PIN, DRILLED
20	1-2714	PIN, HAIR COTTER 5/32 x 1-13/16
21	9-0587	BOLT, 3/8 x 1-1/4 BOLT

CHAIN DRIVE, DRIVEN BELT

36" TILLER

SEE PAGE 36.8 for DRIVE SHEAVE

RIGHT SIDE SHOWN -
REVERSE ORDER ON LEFT

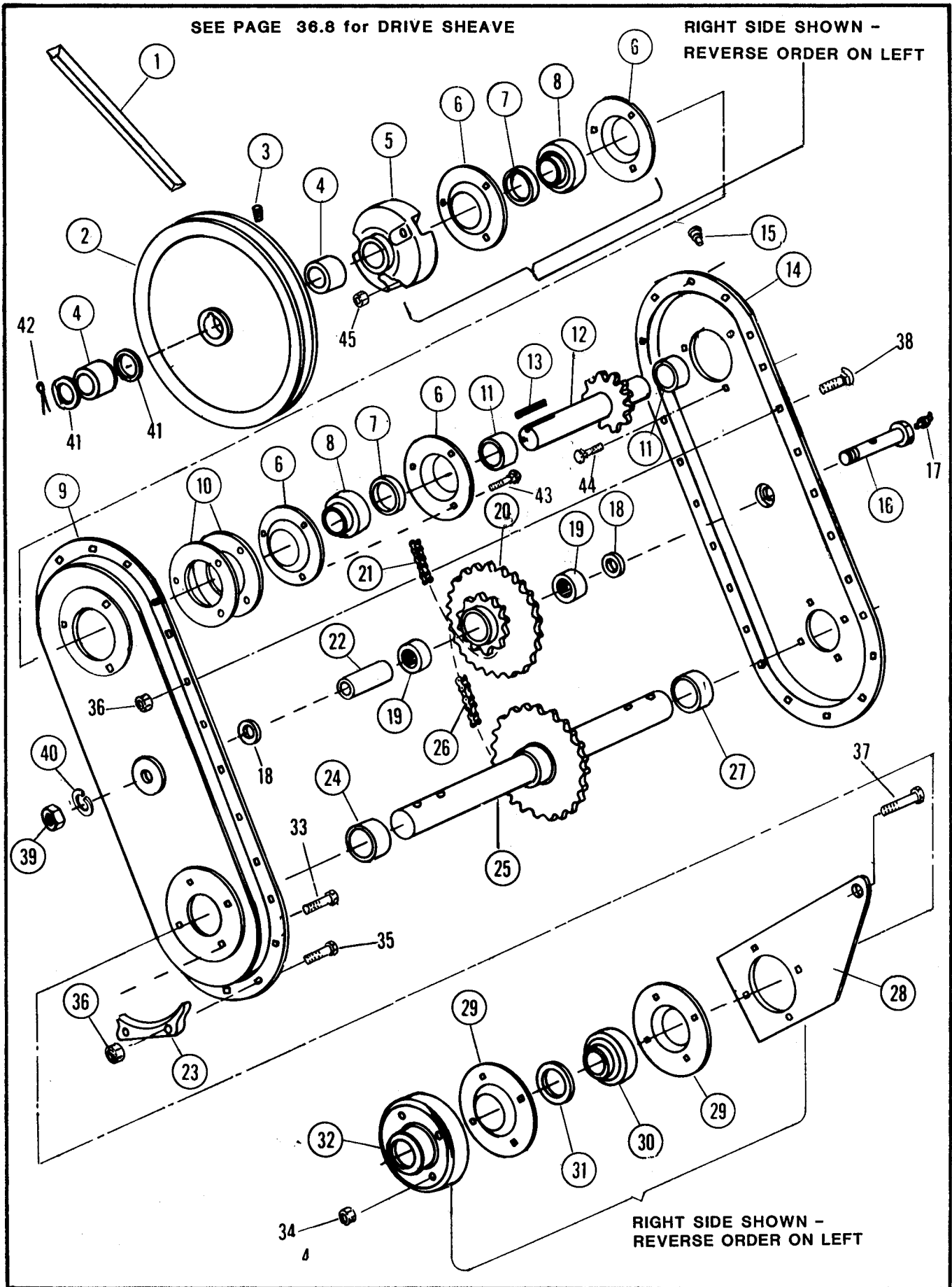

36" TILLER**CHAIN DRIVE, DRIVEN BELT**

ITEM	PART NO.	DESCRIPTION
1	1-3205	BELT, DRIVE
2	1-3204	SHEAVE, DRIVEN
3	1-3261	SETSCREW, 5/16 x 1/2 HEX SOCKET
4	1-3086	SPACER (2)
5	1-3087	HUB, PIVOT (2)
6	1-3265	FLANGETTE
7	1-3064	LOCK-COLLAR
8	1-3032	BEARING
9	1-3206	HOUSING, CHAIN CASE - RIGHT HAND
10	1-3787	SPACER, UPPER RING (2)
11	1-3788	SPACER, UPPER SHAFT (2)
12	1-3208	SHAFT & SPROCKET - UPPER
13	1-3250	KEY, SQUARE
14	1-3207	HOUSING, CHAIN CASE - LEFT HAND
15	1-3093	COVER, OIL HOLE
16	1-3215	BOLT, SPECIAL
17	1-3793	FITTING, LUBE
18	1-3214	WASHER, THRUST (2)
19	1-3033	BEARING, NEEDLE (2)
20	1-3212	CLUSTER SPROCKET
21	1-3211	CHAIN, UPPER
22	1-3213	BEARING, TUBE
23	1-3084	WEAR-BAR (2)
24	1-3219	SPACER, LONG
25	1-3217	SHAFT, TINE
26	1-3216	CHAIN, TINE SHAFT DRIVE
27	1-3218	SPACER, SHORT
28	1-3092	PLATE, ATTACHING (2)
29	1-3252	FLANGETTE (4)
30	1-3002	BEARING (2)
31	1-3259	LOCK-COLLAR (2)
32	1-3091	CAP, BEARING GUARD (2)
33	9-0497	BOLT, 3/8 x 1-1/2 CARRIAGE (8)
34	9-0593	LOCKNUT, 3/8-16 HEX (16)
35	9-0505	BOLT, 1/4 x 2 HEX HEAD (2)
36	9-0761	LOCKNUT, 1/4-20 HEX (2)
37	9-0656	BOLT, 1/4 x 4 HEX HEAD
38	9-0675	BOLT, 1/4 x 1/2 CARRIAGE (11)
39	9-0625	NUT, 1/2-20 HEX
40	9-0254	LOCKWASHER
41	1-3370	WASHER, SPECIAL (2)
42	9-0297	PIN, 1/8 x 1-1/2 COTTER (2)
43	9-0760	BOLT, 5/16-18 x Z CARRIAGE (3)
44	9-0192	BOLT, 5/16-18 x 1-1/2 CARRIAGE (3)
45	9-0194	NUT, 5/16-18 HEX LOCK (6)

GEAR BOX, DRIVE SHEAVE

36" TILLER

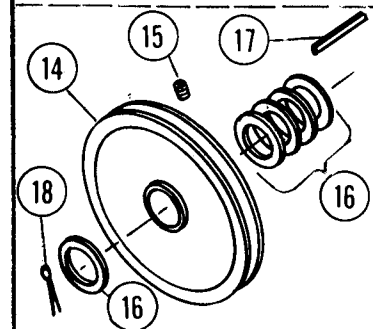
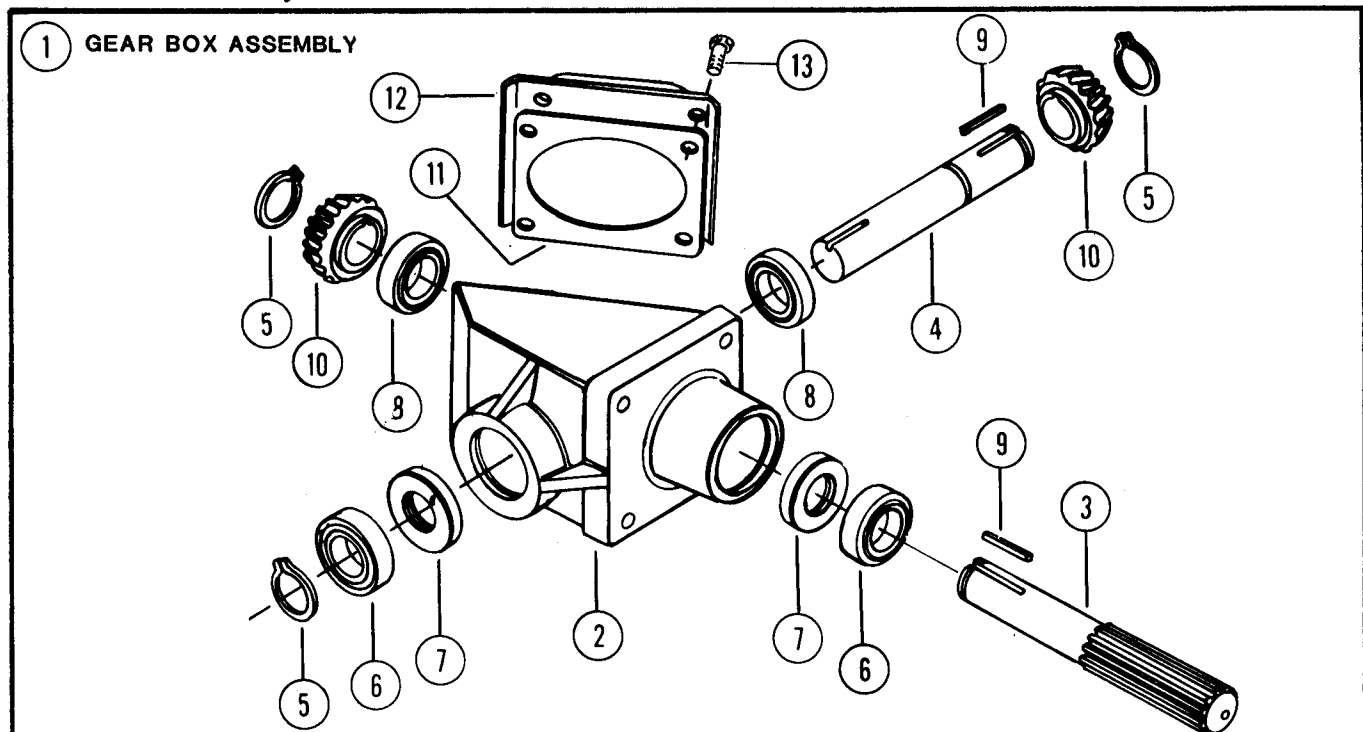

• SEE PAGES 36.6 & 7 for DRIVEN SHEAVE
 • SEE PAGE 36.5 for DRIVE BELT SHIELDS

ITEM	PART NO.	DESCRIPTION
1	1-3198	GEAR BOX ASSEMBLY, 1:1 RATIO (INCLUDES ITEMS 2 THRU 13)
2	1-3780	HOUSING, GEAR BOX
3	1-3781	SHAFT
4	1-3782	SHAFT
5	1-2899	RING, RETAINING (3)
6	1-3443	BEARING, BALL - OUTER (2)
7	1-3789	SEAL, OIL (2)
8	1-3790	BEARING, BALL - INNER (2)
9	1-3000	KEY (2)
10	1-3783	GEAR (2)
11	1-3784	GASKET, LID
12	1-3785	LID
13	1-3791	BOLT, LID RETAINING (4)
14	1-3786	SHEAVE, DRIVE
15	1-3261	SETSCREW, 5/16-18 x 1/2 HEX SOCKET
16	1-3071	WASHER, SPECIAL (5)
17	1-3249	KEY, SQUARE
18	9-0297	PIN, 1/8 x 1-1/2 COTTER

42" TILLER INDEX

ATTACHMENT # 6-0374

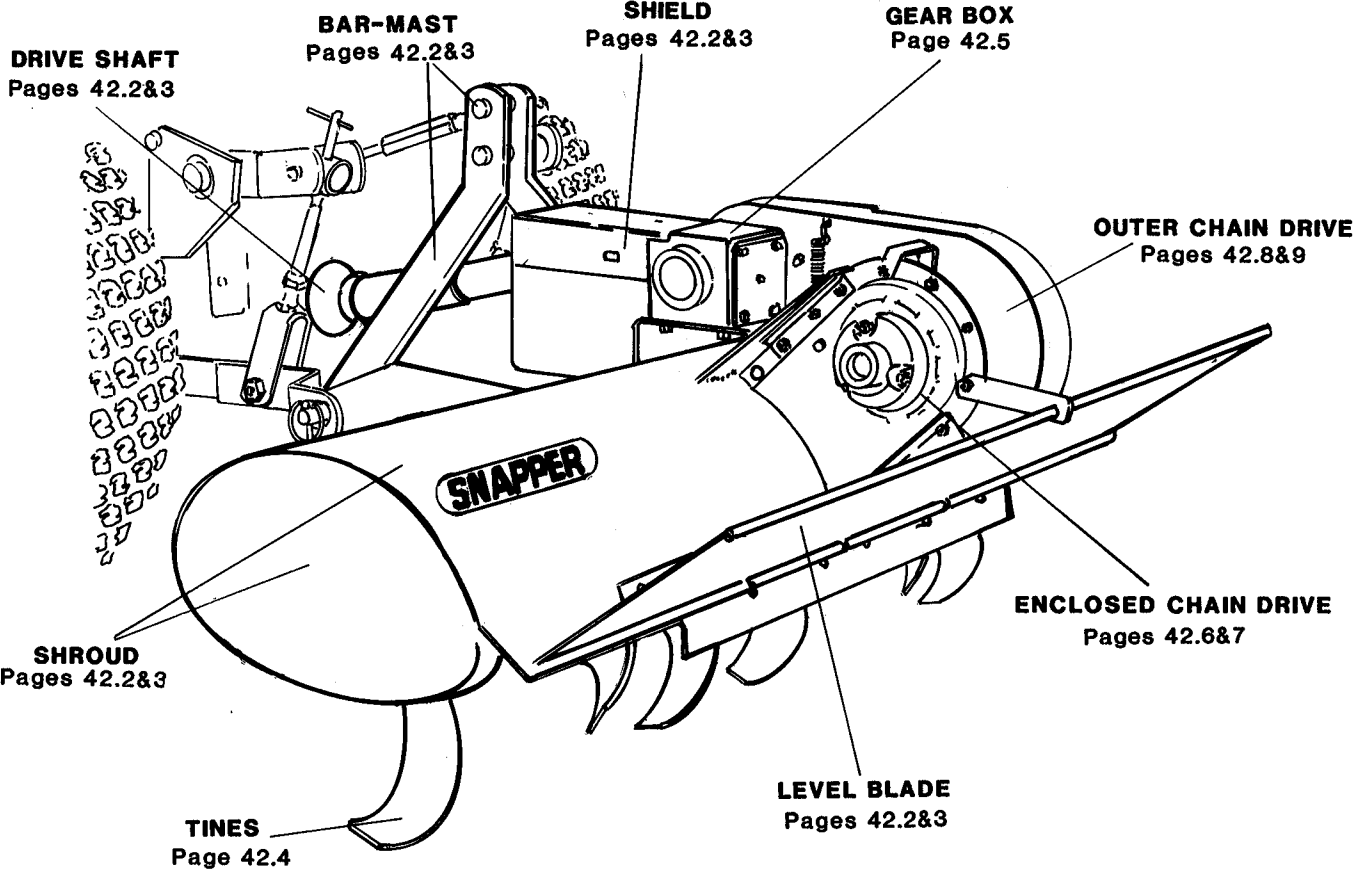

42" GENERAL SPECIFICATIONS

OVERALL WIDTH	-----	44 INCHES
WEIGHT (APPROXIMATE)	-----	200 LBS.
SHIPPING WEIGHT	-----	230 LBS.
TILLING WIDTH	-----	42 INCHES
TILLER TIPS (NUMBER)	-----	24
TILLING DEPTH (MAXIMUM)	-----	8 INCHES
TINE MATERIAL	-----	HIGH CARBON, HEAT TREATED STEEL
TINE RETAINING BOLT TORQUE	-----	50 to 55 FT. LBS.
TINE SPEED	-----	190 RPM at 2000 PTO SPEED.
OPERATOR'S/SERVICE MANUAL	-----	# 1-3302

SHROUD, LEVEL BLADE, DRIVE

42" TILLER

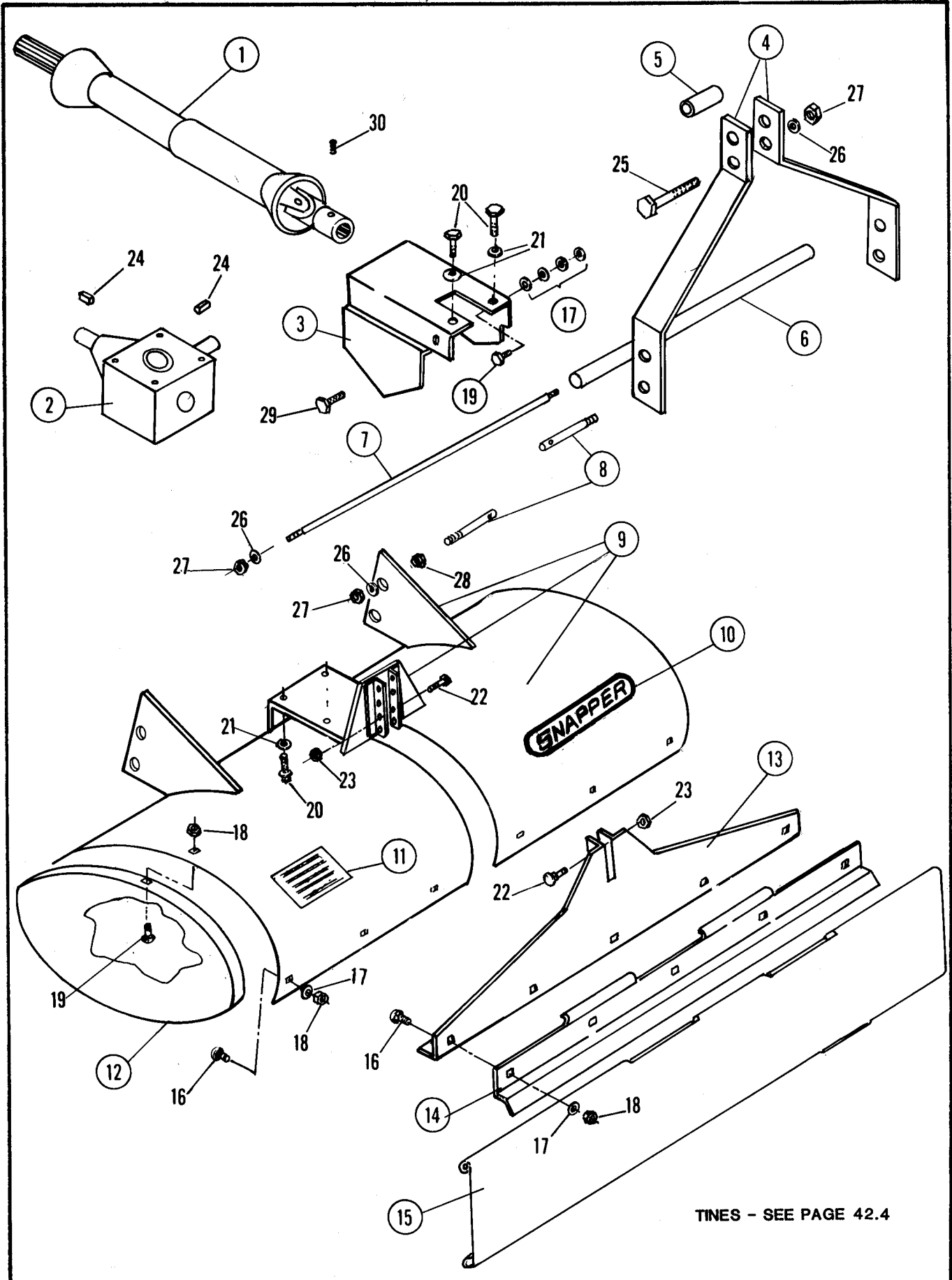

42" TILLER

SHROUD, LEVEL BLADE, DRIVE

ITEM	PART NO.	DESCRIPTION
1	1-3149	SHAFT, P.T.O. (COMPLETE ASSEMBLY)
2	1-3152	GEAR BOX - COMPLETE (SEE PAGE 42.5 for PARTS BREAKDOWN)
3	1-3184	SHIELD, P.T.O. EXTENSION
4	1-3147	BAR-MAST (SAME BOTH SIDES)
5	1-3182	SPACER, MAST
6	1-3958	TUBE, LOWER TIE
7	1-3959	ROD, LOWER TIE
8	1-3148	PIN, LOWER LINK
9	1-3127	SHROUD ASSEMBLY
10	1-9668	DECAL, SNAPPER
11	1-8443	DECAL, CAUTION
12	1-3095	COVER, SHROUD END (SAME BOTH SIDES)
13	1-3354	BRACE, SHROUD
14	1-3355	HINGE, LEVEL BLADE
15	1-3146	LEVEL BLADE
16	9-0001	BOLT, 5/16-18 x 3/4 CARRIAGE (11)
17	9-0692	WASHER, 5/16 SAE
18	9-0194	LOCKNUT, 5/16-18 HEX
19	9-0731	BOLT, 5/16-18 x 1/2 CARRIAGE (6)
20	9-0368	BOLT, 5/16-18 x 3/4 HEX HEAD (6)
21	9-0187	LOCKWASHER, 5/16 MEDIUM (6)
22	9-0078	BOLT, 1/4-20 x 1-1/4 CARRIAGE
23	9-0761	LOCKNUT, 1/4-20 HEX
24	1-3249	KEY, 3/16 SQUARE
25	9-0778	BOLT, 5/8-11 x 2-3/4 HEX HEAD
26	9-0333	LOCKWASHER 5/8 MEDIUM (5)
27	9-0537	NUT, 5/8-11 HEX (5)
28	9-0686	JAM-NUT, 5/8-11 HEX (2)
29	9-0505	BOLT, 1/4-20 x 2 HEX HEAD
30	1-3261	SETSCREW, 5/16-18 x 1/2 LOCKING

TINES

42" TILLER

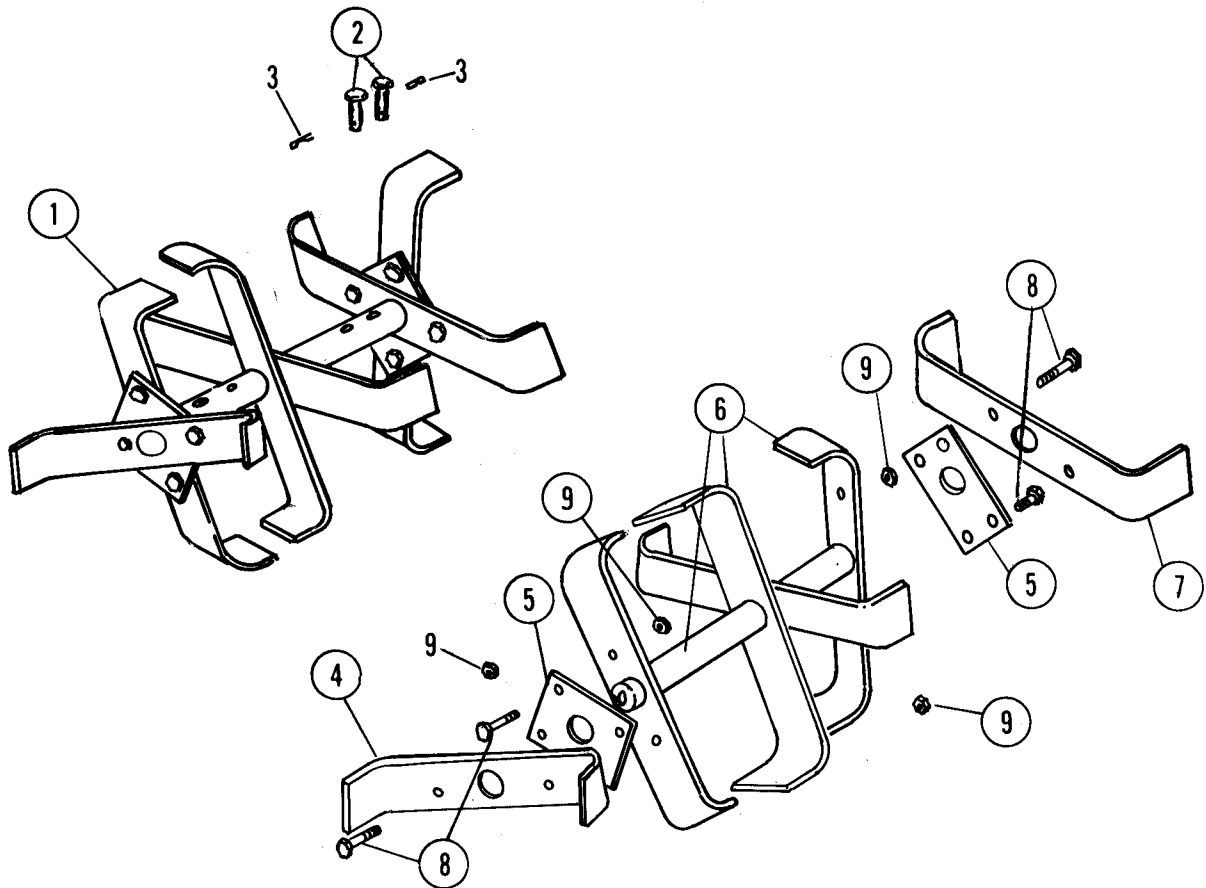

ITEM	PART NO.	DESCRIPTION
1	1-3102	TINE ASSEMBLY (2- SAME BOTH SIDES)
2	1-3100	PIN, TINE SHEAR (4)
3	9-0041	PIN, 1/8D x 1 COTTER (4)
4	1-3098	TINE, LEFT HAND (2)
5	1-3096	PLATE, TINE ATTACHING (4)
6	1-3103	TINE-TUBE ASSEMBLY (2)
7	1-3097	TINE, RIGHT HAND (2)
8	9-0762	BOLT, 7/16-14 x 1 HEX HEAD (16)
9	9-0739	LOCKNUT, 7/16-14 HEX (16)

42" TILLER

GEAR BOX

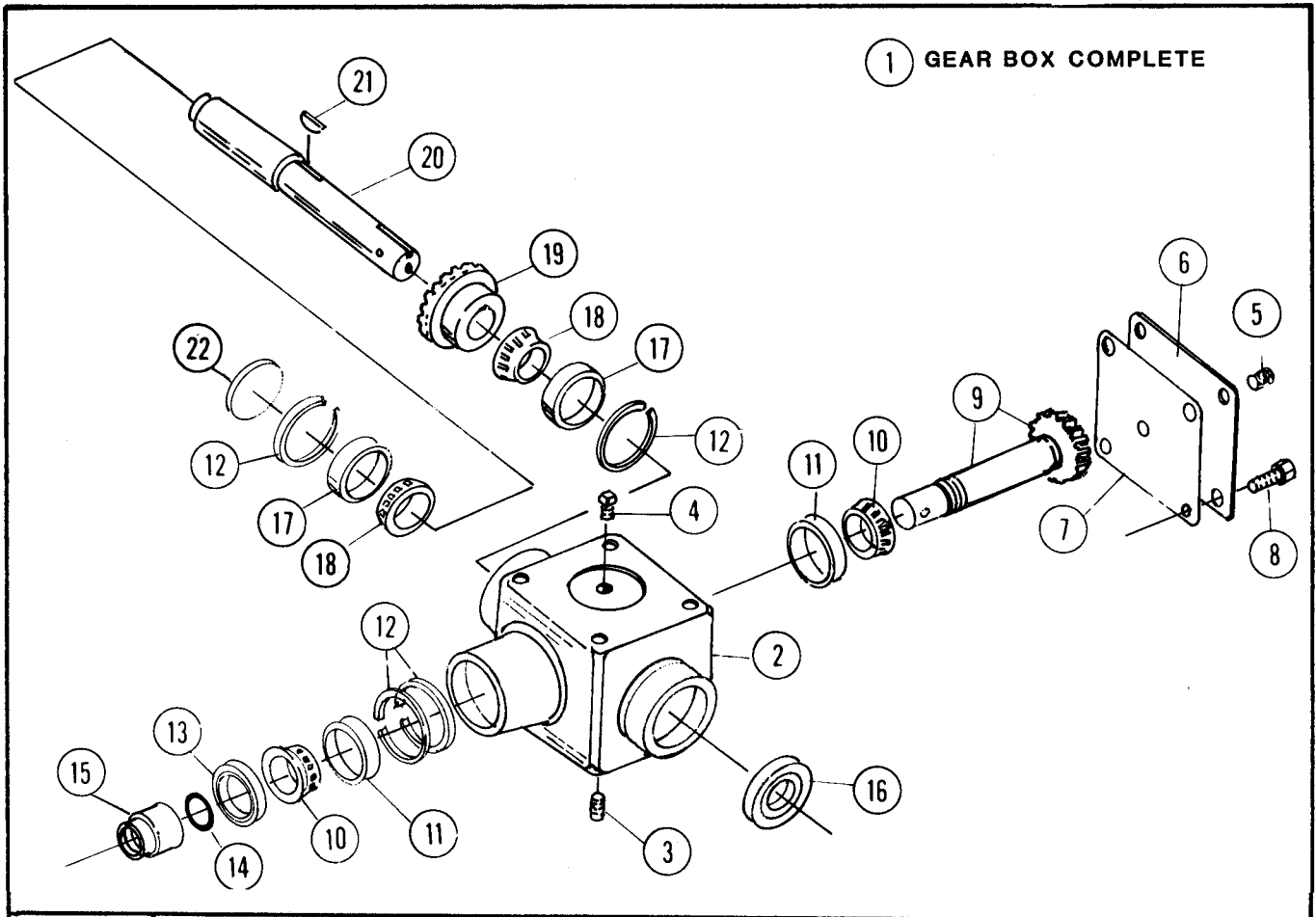

① GEAR BOX COMPLETE

ITEM	PART NO.	DESCRIPTION
1	1-3152	GEAR BOX ASSY (DURST #4477) INCLUDES FOLLOWING
2	1-3328	HOUSING, GEAR BOX
3	1-3345	PLUG, DRAIN 3/8-18 NPT SOCKET HEAD
4	1-3346	PLUG, VENT 3/8-18 NPT SQUARE HEAD
5	1-3344	PLUG, CHECK 1/8-27 NPT
6	1-3342	COVER
7	1-3343	GASKET, COVER
8	1-3347	SCREW, 5/16-18 x 1/2 HEX HEAD CAP (4)
9	1-3329	SHAFT, BEVEL PINION
10	1-3332	BEARING CONE (2)
11	1-3331	BEARING CUP (2)
12	1-3333	RING, RETAINING (4)
13	1-3337	SEAL, OIL
14	1-3340	O-RING
15	1-3338	STAKE-NUT
16	1-3336	SEAL, OIL
17	1-2931	BEARING CUP
18	1-8315	BEARING CONE
19	1-3330	GEAR, BEVEL 28T-10P
20	1-3334	SHAFT, OUTPUT
21	1-2699	KEY, WOODRUFF (#9-606 HARD)
22	1-3339	CAP, END

ENCLOSED CHAIN DRIVE

42" TILLER

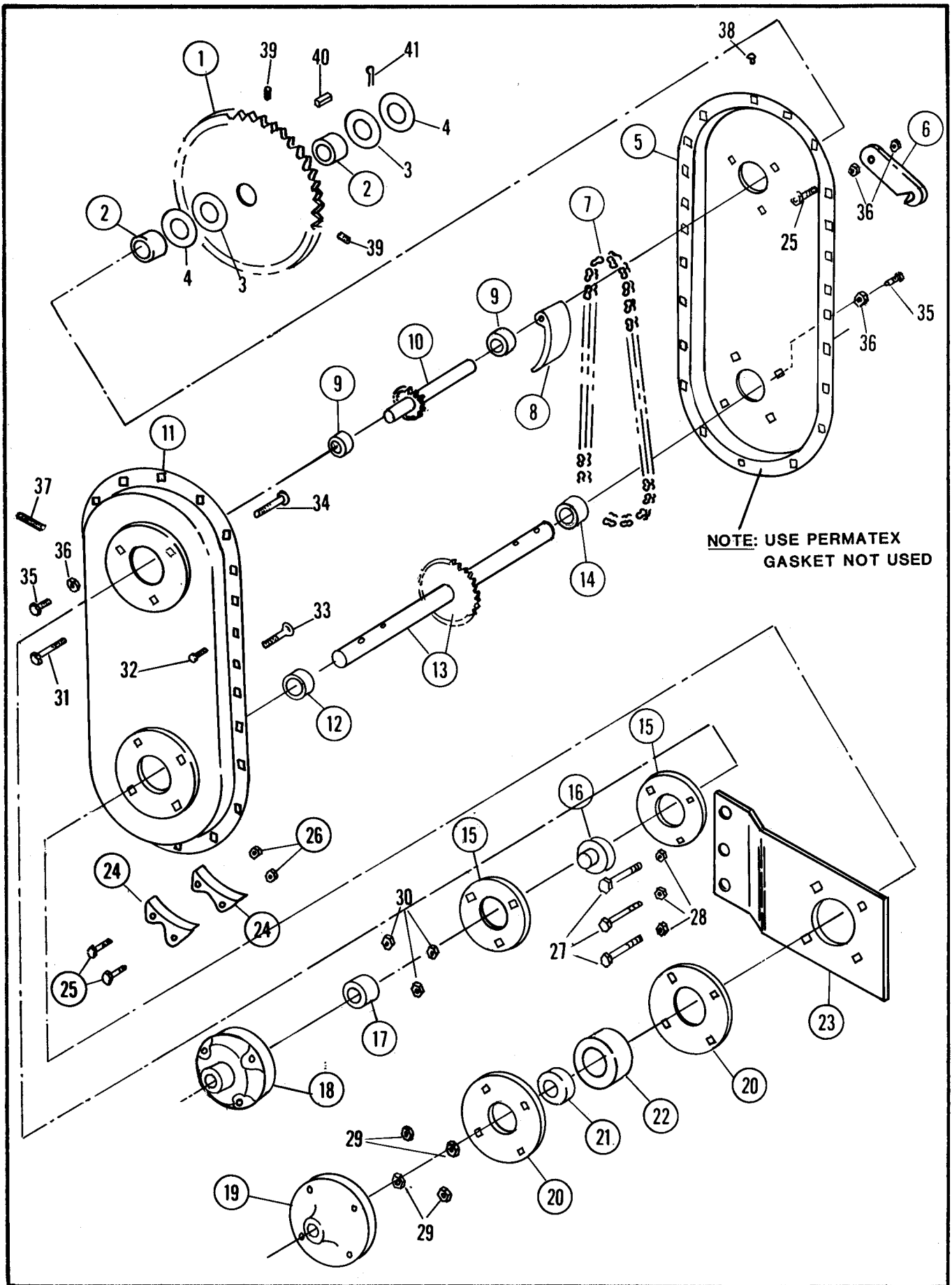

42" TILLER**ENCLOSED CHAIN DRIVE**

ITEM	PART NO.	DESCRIPTION
1	1-3141	SPROCKET - HUB 40 TOOTH
2	1-3185	SPACER, 40T SPROCKET (2)
3	1-3099	WASHER, SPECIAL (INNER) (2)
4	1-3370	WASHER, SPECIAL OUTER (2)
5	1-3087	HOUSING, RIGHT SIDE CHAIN
6	1-3356	STRAP, HINGE LOCK
7	1-3260	CHAIN, ROLLER DRIVE
8	1-3088	PADDLE, CHAIN TIGHTENER
9	1-3086	SPACER, DRIVE SHAFT (2)
10	1-3085	SPROCKET SHAFT
11	1-3083	HOUSING, LEFT SIDE CHAIN
12	1-3090	SPACER, TINE SHAFT SHORT
13	1-3367	TINE SHAFT & SPROCKET
14	1-3089	SPACER, TINE SHAFT LONG
15	1-3265	FLANGETTE, 3-HOLE (4)
16	1-3032	BEARING, SPROCKET SHAFT (2)
17	1-3064	LOCK-COLLAR, BEARING (2)
18	1-3087	HUB, PIVOT
19	1-3091	CAP, BEARING GUARD (DUST) (2)
20	1-3252	FLANGETTE, 4-HOLE (4)
21	1-3259	LOCK-COLLAR, TINE SHAFT BEARING (2)
22	1-3002	BEARING, TINE SHAFT (2)
23	1-3145	PLATE, LOWER ATTACHING (2)
24	1-3084	WEAR-BAR (2)
25	9-0505	BOLT, 1/4-20 x 2"
26	9-0761	LOCKNUT, 1/4-20 HEX
27	9-0766	BOLT, 1/2-13 x 2 HEX HEAD (3)
28	9-0706	LOCKNUT, 1/2-13 HEX (3)
29	9-0593	LOCKNUT, 3/8-16 HEX
30	9-0194	LOCKNUT, 5/16-18 HEX
31	9-0689	BOLT, 5/16-18 x 2 HEX HEAD (1)
32	9-0064	BOLT, 1/4-20 x 3/4 CARRIAGE (8)
33	9-0497	BOLT, 3/8-16 x 1-3/4 CARRIAGE (8)
34	9-0192	BOLT, 5/16-18 x 1-1/2 CARRIAGE (6)
35	9-0675	BOLT, 1/4-20 x 1/2 SN CARRIAGE (4)
36	9-0761	LOCKNUT, 1/4-20 HEX
37	9-0787	SETSCREW, 5/16-18 x 1-1/2 HEX SOCKET
38	1-3093	COVER, OIL HOLE
39	1-3369	SETSCREW, 5/16 x 1/4 (2)
40	1-3250	KEY, 1/4 SQUARE x 1
41	9-0042	COTTER-PIN, 1/8D x 1-1/4

OUTER CHAIN DRIVE

42" TILLER

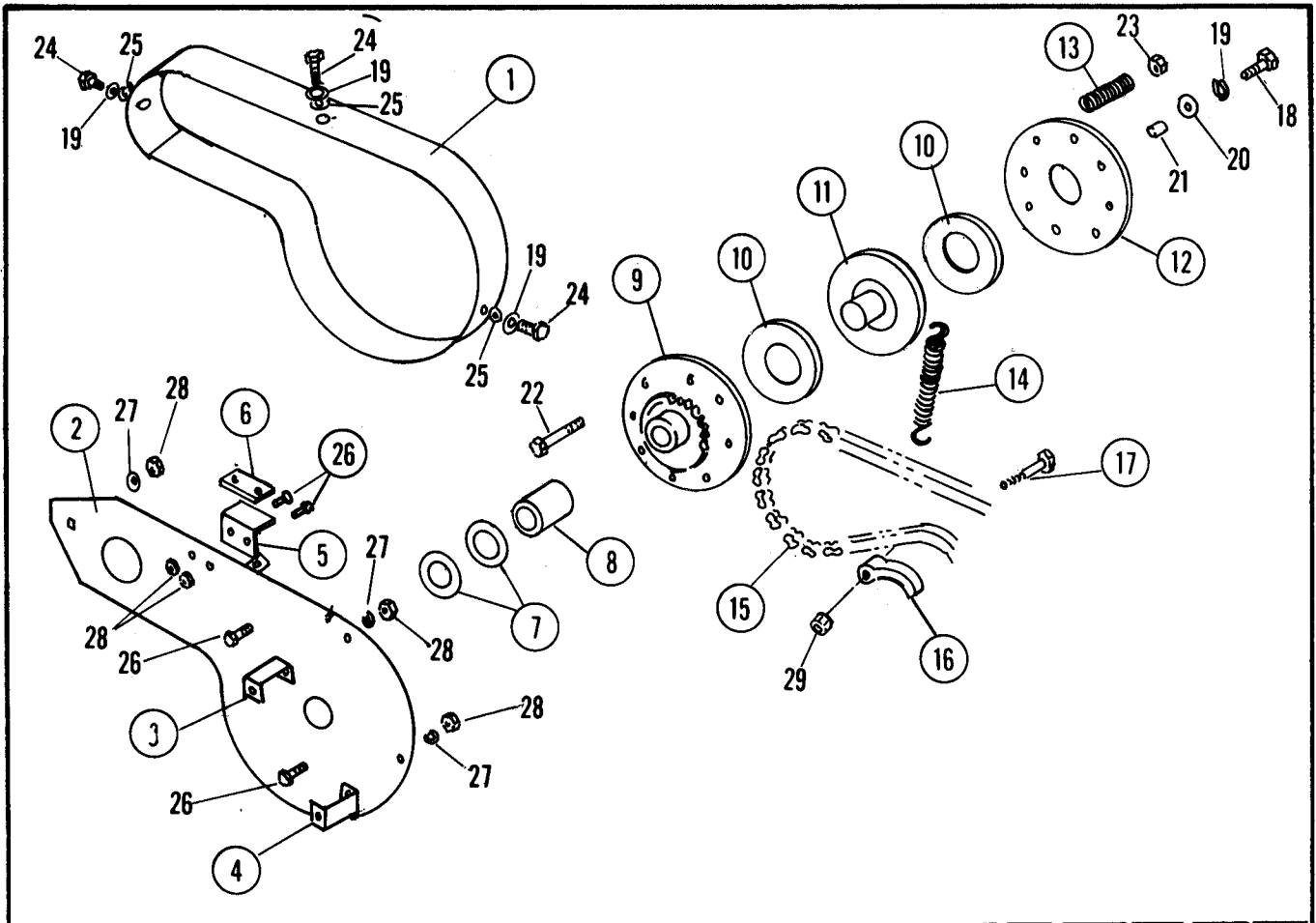

ASSEMBLED VIEW (FROM RIGHT SIDE)

STRAP, LOCK
SEE PAGES 42.6 & 7

DRIVEN SPROCKET
SEE PAGES 42.6 & 7

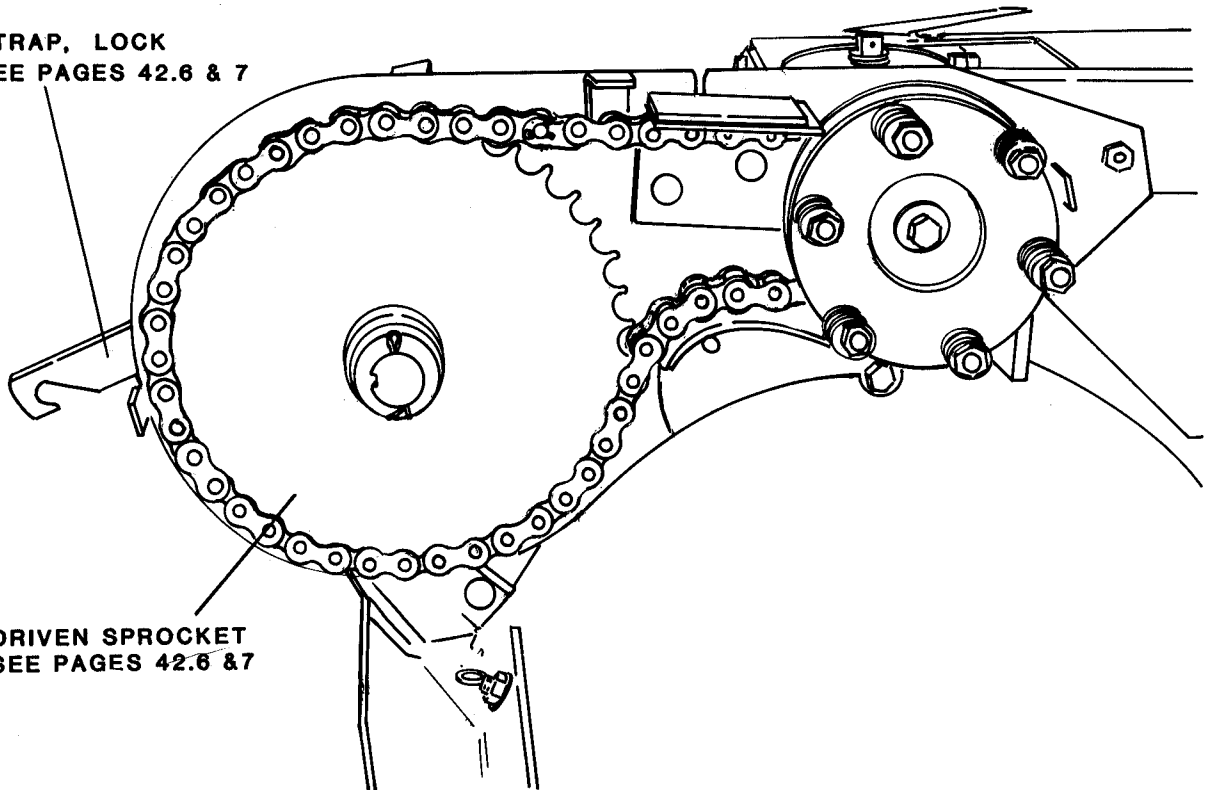

42" TILLER

OUTER CHAIN DRIVE

ITEM	PART NO.	DESCRIPTION
1	1-3128	GUARD, OUTER CHAIN
2	1-3129	GUARD, INNER CHAIN
3	1-3130	BRACE, UPPER REAR
4	1-3368	BRACE, LOWER REAR
5	1-3371	BRACKET, CHAIN DAMPENER
6	1-3372	PAD, CHAIN DAMPENER
7	1-3071	WASHER, SPECIAL (4)
8	1-3133	SPACER, SPROCKET - HUB ASSEMBLY
9	1-3132	SPROCKET & HUB ASSEMBLY
10	1-3135	DISC, CLUTCH (2)
11	1-3136	HUB, DISC MOUNTING
12	1-3134	PLATE, PRESSURE
13	1-3137	SPRING, TORQUE LIMITER (6)
14	1-3143	SPRING, EXTERNAL
15	1-3140	CHAIN, ROLLER
16	1-3142	PADDLE, CHAIN ADJUSTING
17	9-0702	BOLT, 5/16-18 x 2 HEX HEAD
18	9-0368	BOLT, 5/16-18 x 3/4 HEX HEAD
19	9-0187	LOCKWASHER, 5/16 MEDIUM
20	1-3139	WASHER, SPECIAL
21	1-3138	SPACER, TORQUE LIMITER
22	9-0219	BOLT, 5/16-18 x 2-1/2 HEX HEAD (7)
23	9-0194	LOCKNUT, 5/16-18 HEX
24	9-0203	BOLT, 5/16-18 x 1/2 HEX HEAD (3)
25	9-0692	WASHER, 5/16 SAE PLAIN
26	9-0675	BOLT, 1/4-20 x 1/2 SHORT NECK CARRIAGE
27	9-0598	WASHER, 1/4 SAE PLAIN
28	9-0761	LOCKNUT, 1/4-20 HEX
29	9-0196	NUT, HEX 5/16-18

48" TILLER INDEX

ATTACHMENT #6-0375

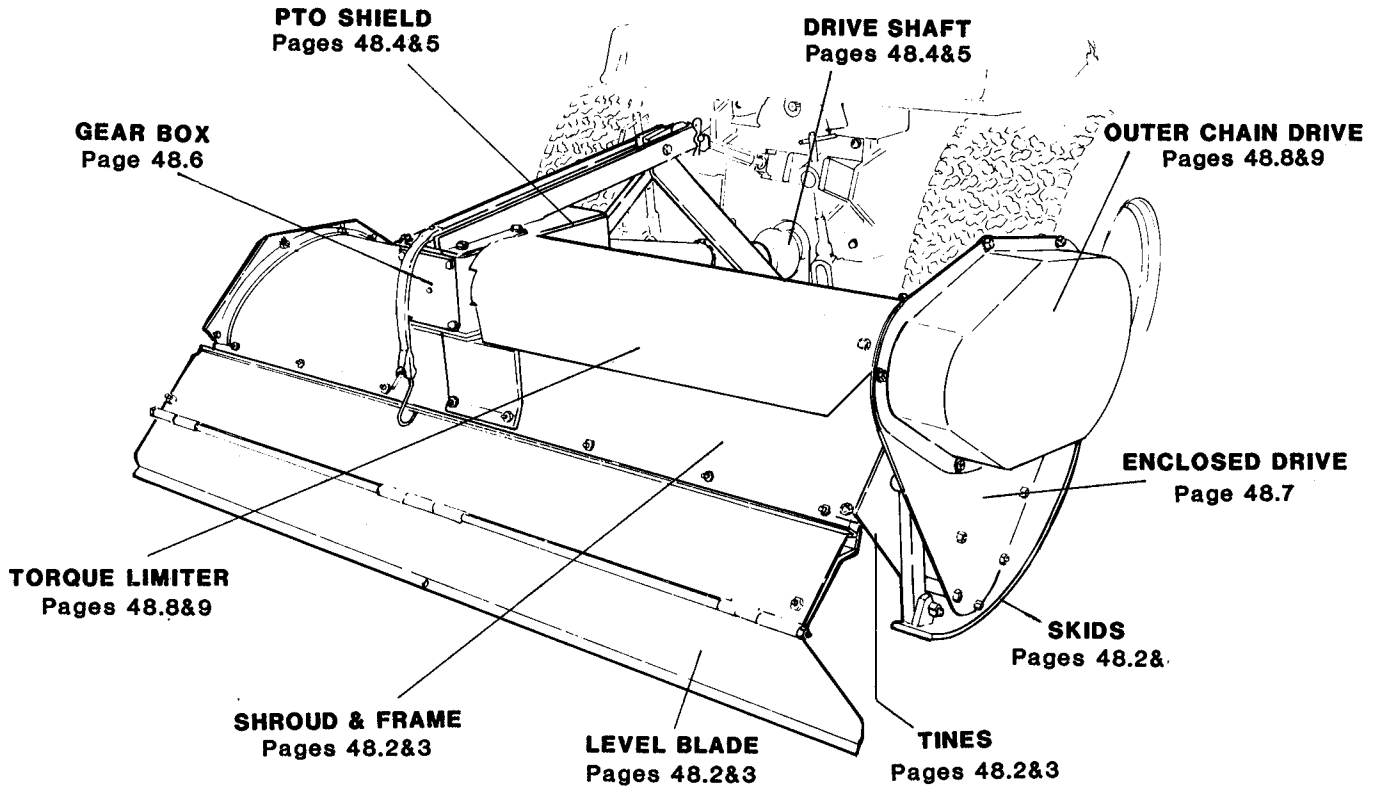

48" GENERAL SPECIFICATIONS

OVERALL WIDTH	-----	59 INCHES
WEIGHT (APPROXIMATE)	-----	320 LBS
SHIPPING WEIGHT	-----	385 LBS
TILLING WIDTH	-----	48 INCHES
TILLER TIPS (NUMBER)	-----	8 INCHES
TINE MATERIAL	-----	HIGH CARBON, HEAT TREATED STEEL
TINE RETAINING BOLT TORQUE	-----	50 to 55 FT. LBS
TINE SPEED	-----	200 RPM at 2000 PTO SPEED
OPERATOR'S/SERVICE MANUAL	-----	# 1-3940

FRAME, SHROUD, TINES

48" TILLER

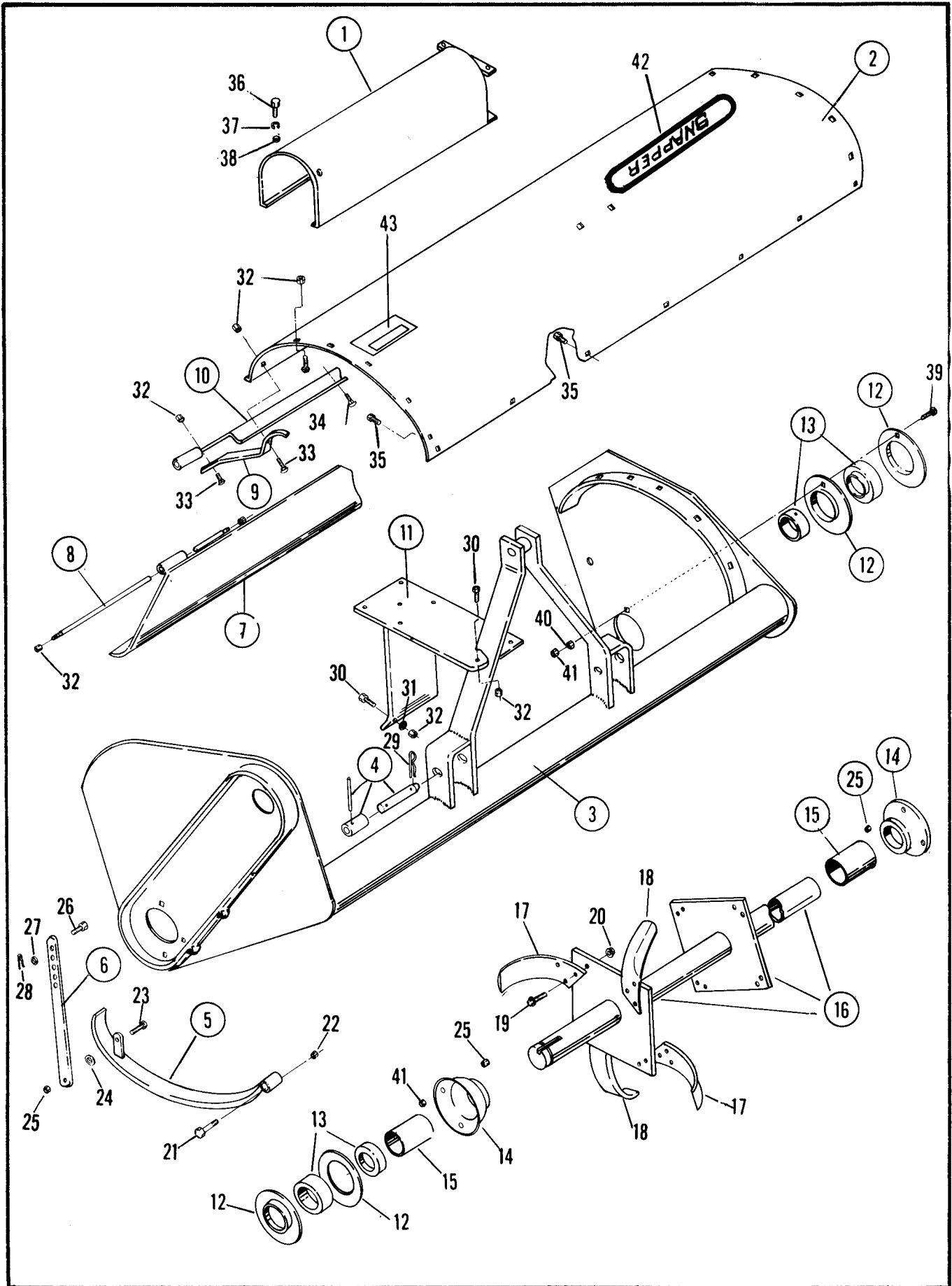

48" TILLER**FRAME, SHROUD, TINES**

ITEM	PART NO.	DESCRIPTION
1	1-3973	SHIELD, TORQUE LIMITER TUNNEL
2	1-3966	SHROUD, TILLER
3	1-3964	FRAME,
4	1-3181	PIN ASSEMBLY
5	1-3978	SKID
6	1-3979	STRAP, ADJUSTING
7	1-3157	LEVEL - BLADE
8	1-3158	ROD, HINGE
9	1-3980	STRAP, SUPPORT
10	1-3969	BRACKET, HINGE
11	1-3968	MOUNT, GEAR BOX
12	1-2999	FLANGETTE, 4-HOLE (4)
13	1-3262	BEARING, SEALED (2-WITH LOCK COLLAR 1-1/2")
14	1-3171	CAP, BEARING GUARD (DUST)
15	1-3170	TUBE, TINE SHAFT LOCK
16	1-3167	SHAFT, TINE
17	1-3168	TINE, SINGLE RIGHT HAND (12 REQUIRED)
18	1-3169	TINE, SINGLE LEFT HAND (12 REQUIRED)
19	1-3813	BOLT, HEX FLANGED HEAD (48)
20	9-0593	LOCKNUT, HEX FLANGED (48)
21	9-0778	BOLT, 5/8-11 x 2-3/4 HEX - GRADE 5 (2)
22	9-0537	NUT, 5/8-11 HEX (2)
23	9-0330	BOLT, 1/2-13 x 1-1/2 HEX - GRADE 2 (2)
24	1-3954	WASHER, RUBBER
25	9-0706	LOCKNUT, 1/2-13 HEX
26	1-3956	BOLT, SPECIAL HEX (2)
27	9-0705	WASHER, 1/2" PLAIN (4)
28	1-2867	PIN, COTTER HAIR 1/8 x 1-7/8 (2)
29	1-3256	PIN, COTTER HAIR (2)
30	9-0563	BOLT, 3/8-16 x 1" HEX - GRADE 5 (6)
31	9-0122	WASHER, 3/8 PLAIN (8)
32	9-0593	LOCKNUT, 3/8-16 HEX (26 TOTAL)
33	9-0645	BOLT, 3/8-16x1" CARRIAGE (4)
34	9-0136	BOLT, 3/8-16 x 3/4 CARRAIGE (20 TOTAL)
35	9-0765	SCREW, 5/16-18 x 3/4 SELF-TAPPING (7)
36	9-0203	SCREW, 5/16-18 x 1/2 HEX HEAD (2)
37	9-0187	LOCKWASHER, 5/16
38	9-0692	WASHER, 5/16 SAE PLAIN (2)
39	9-0769	BOLT, 1/2-13 x 1-3/4 GR. 5 CARRIAGE (4)
40	9-0258	NUT, 1/2-13 HEX (8)
41	1-3172	SPACER, BEARING CAP (4)
42	1-9668	DECAL, SNAPPER
43	1-3953	DECAL, CAUTION

PTO SHAFT, SHIELD, GEAR BOX

48" TILLER

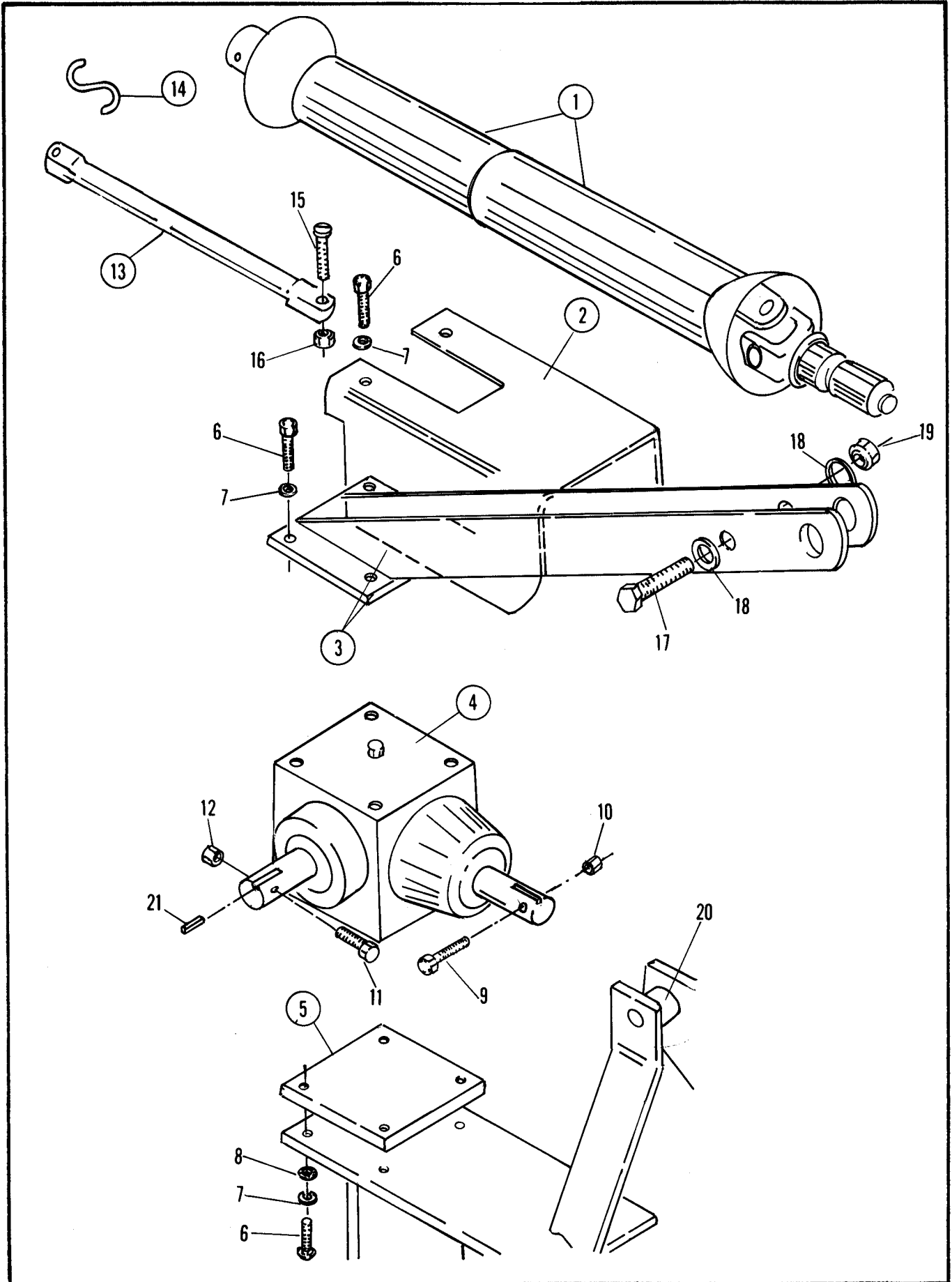

48" TILLER**PTO SHAFT, SHIELD, GEAR BOX**

ITEM	PART NO.	DESCRIPTION
1	1-3974	SHAFT, TELESCOPING PTO
2	1-3962	SHIELD, POWER TAKE OFF
3	1-3965	LINK, UPPER
4	1-3961	GEAR BOX, 2:1 RATIO (COMPLETE:SEE PAGE 48.6 for BREAKDOWN)
5	1-3981	SPACER PLATE, GEAR BOX
6	9-0587	BOLT, 3/8-16 x 1 -1/4 HEX - GRADE 5 (6)
7	9-0118	LOCKWASHER, 3/8
8	9-0122	WASHER, 3/8 PLAIN
9	9-0588	BOLT, 3/8-16 x 2 HEX - GRADE 5
10	9-0593	LOCKNUT, 3/8-16 HEX
11	9-0371	BOLT, 1/4-20 x 2-1/2 HEX - GRADE 2
12	9-0761	LOCKNUT, 1/4-20 HEX
13	1-3179	STRAP, RUBBER
14	1-3180	"S" HOOK
15	9-0764	SCREW, 1/4-20 x 1-1/4 ROUND HEAD MACHINE
16	9-0063	NUT, 1/4-20 HEX
17	9-0779	SCREW, 1/2-13 x 3-1/2 HEX HEAD CAP - GRADE 5
18	9-0705	WASHER, 1/2 PLAIN
19	9-0706	LOCKNUT, 1/2-13 HEX
20	1-3999	SPACER, MAST
21	1-3250	KEY, 1/4 SQ. x 1

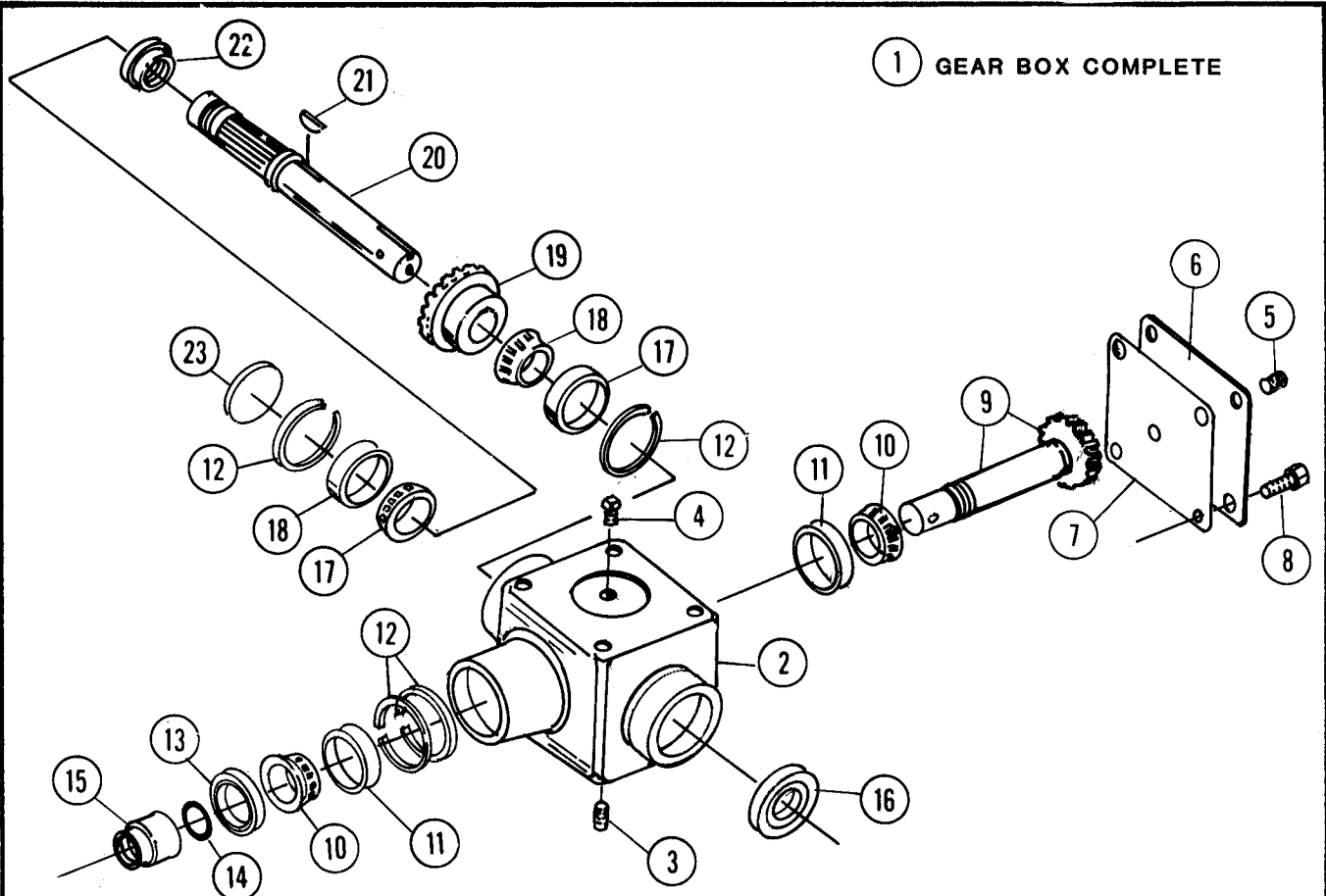

① GEAR BOX COMPLETE

ITEM	PART NO.	DESCRIPTION
1	1-3961	GEAR BOX ASSY (DURST # 4465) INCLUDES FOLLOWING
2	1-4020	HOUSING, GEAR BOX
3	1-3345	PLUG, DRAIN 3/8-18 NPT
4	1-4038	PLUG, VENT 3/8-18 NPT SQUARE HEAD
5	1-3344	PLUG, CHECK 1/8-27 NPT
6	1-4021	COVER
7	1-4035	GASKET, COVER
8	1-4030	SCREW, 5/16-18 x 5/8 HEX HEAD CAP (4)
9	1-4023	SHAFT, BEVEL PINION
10	1-4027	BEARING CONE (2)
11	1-4026	BEARING CUP (2)
12	1-4029	RING, RETAINING (4)
13	1-4039	SEAL, OIL VICTOR #64494
14	1-4037	O-RING, NS 122
15	1-4031	STAKE-NUT
16	1-4036	SEAL, OIL
17	1-4025	BEARING CUP
18	1-4024	BEARING CONE
19	1-4022	GEAR, BEVEL 32T - 10P
20	1-4032	SHAFT, OUTPUT
21	1-4033	KEY, WOODRUFF (A 807 HARD)
22	1-4028	STAKE-NUT
23	1-4034	CAP, END

ENCLOSED DRIVE

48" TILLER

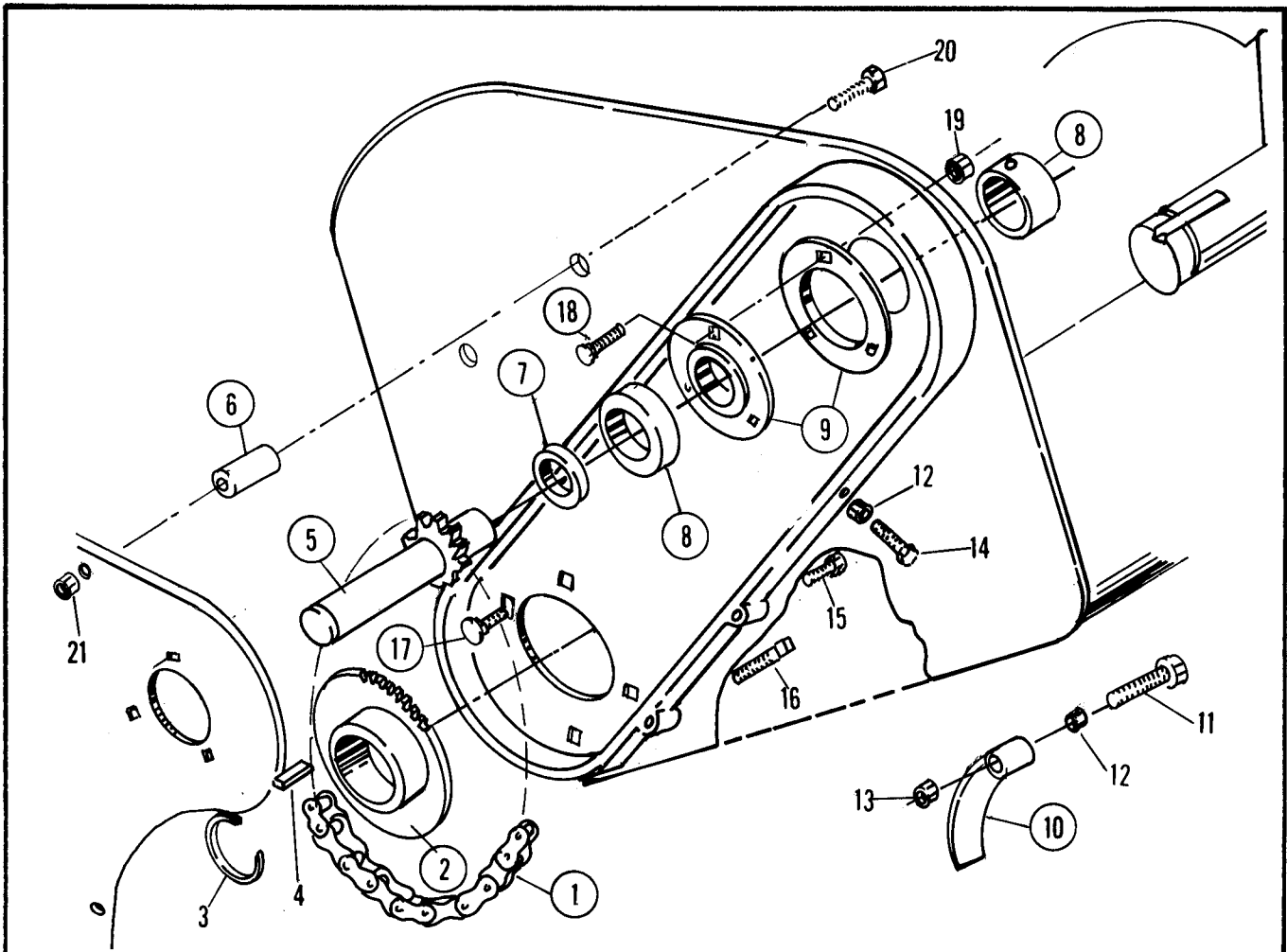

ITEM	PART NO.	DESCRIPTION
1	1-3165	CHAIN, ENCLOSED DRIVE (60A, 46 PITCHES)
2	1-3166	SPROCKET & HUB, DRIVEN
3	1-3067	RING, RETAINING
4	1-3255	KEY, 3/8 x 1
5	1-3164	SPROCKET & SHAFT
6	1-3176	TUBE, SUPPORT
7	1-3086	SPACER, UPPER SHAFT
8	1-3263	BEARING, SEALED (WITH LOCK COLLAR 1")
9	1-3251	FLANGETTE, 3-HOLE
10	1-3088	PADDLE, CHAIN TIGHTENER
11	9-0520	BOLT, SPECIAL HEX HEAD
12	9-0196	NUT, 5/16-18 HEX
13	9-0194	LOCKNUT, 5/16-18 HEX
14	9-0787	SETSCREW, HEX SOCKET HEAD
15	9-0738	BOLT, 3/8-16 x 2-3/4 CARRIAGE (8)
16	1-3175	BOLT, 3/8-16 x 2-3/4 SPECIAL CARRIAGE (4)
17	9-0768	BOLT, 1/2-13 x 1-1/2 CARRIAGE - GRADE 5 (4)
18	9-0670	BOLT, 5/16-18 x 3/4 CARRIAGE
19	9-0194	LOCKNUT, 5/16-18 HEX
20	9-0652	BOLT, 1/2-13 x 3" HEX HEAD
21	9-0706	LOCKNUT, 1/2-13 HEX

TORQUE LIMITER & OUTER DRIVE CHAIN

48" TILLER

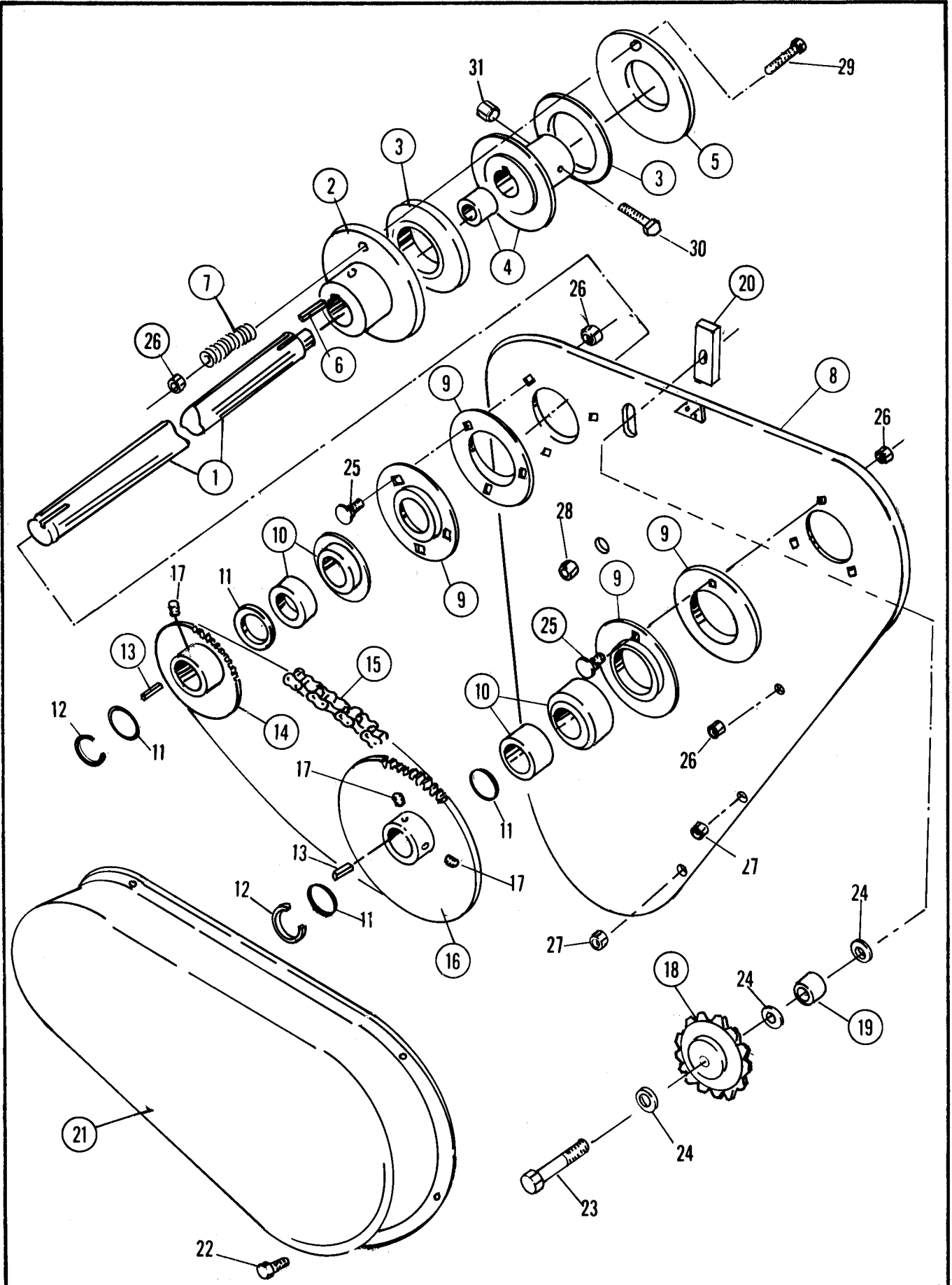

48" TILLER**TORQUE LIMITER & OUTER DRIVE CHAIN**

ITEM	PART NO.	DESCRIPTION
1	1-3982	SHAFT, DRIVE
2	1-3977	PLATE, HUB END
3	1-3135	DISC, CLUTCH
4	1-3983	HUB & BEARING ASSEMBLY
5	1-3988	PRESSURE - PLATE
6	1-2911	KEY, 1/4 SQUARE X 1-1/2
7	1-3963	SPRING, PRESSURE (8)
8	1-3967	COVER, INNER
9	1-3251	FLANGETTE, 3-HOLE (4 OUTSIDE)
10	1-3263	BEARING, SEALED (WITH LOCK COLLAR 1" - 2 OUTSIDE)
11	1-3370	WASHER, 1" I.D. SHIM (4)
12	1-2709	RING, RETAINING (FOR 1" SHAFT)
13	1-3250	KEY, 1/4 SQUARE x 1"
14	1-3817	SPROCKET, 50P, 16 TOOTH
15	1-3975	CHAIN, ASA 50 ROLLER
16	1-3141	SPROCKET, 40 TOOTH
17	1-3261	SETSCREW, HEX SOCKET (5)
18	1-3985	SPROCKET, IDLER
19	1-3971	SPACER, IDLER SPROCKET
20	1-3972	STRAP, IDLER SUPPORT
21	1-3970	SHIELD, OUTER DRIVE COVER
22	9-0361	SCREW, 5/16-18 x 5/8 SELF-TAPPING (6)
23	9-0651	BLOT, 1/2-13 x 2-3/4 HEX - GRADE 5
24	9-0705	NUT, 1/2" PLAIN (2)
25	9-0670	BOLT, 5/16-18 x 3/4 CARRIAGE (9)
26	9-0194	LOCKNUT, 5/16-18 HEX (9)
27	9-0593	LOCKNUT, 3/8-16 HEX (26 TOTAL)
28	9-0706	LOCKNUT, 1/2-13 HEX
29	9-0766	BOLT, 5/16-18 x 2-1/2 HEX - GRADE 5 (8)
30	9-0371	BOLT, 1/4-20 x 2-1/2 HEX - GRADE 2
31	9-0761	LOCKNUT, 1/4-20 HEX