

JAZZY

100

How a Power Chair should FEEL!™



OWNER'S MANUAL

Pride
Mobility Products Corp.
www.pridemobility.com

1-800-800-8586 (US) 1-888-570-1113 (Canada)

SAFETY GUIDELINES



WARNING! An authorized Pride Provider or a qualified technician must perform the initial setup of this power chair and must perform all of the procedures in this manual.

The symbols below are used throughout this owner's manual and on the power chair to identify warnings and important information. It is very important for you to read them and understand them completely.



WARNING! Indicates a potentially hazardous condition/situation. Failure to follow designated procedures can cause either personal injury, component damage, or malfunction. On the product, this icon is represented as a black symbol on a yellow triangle with a black border.



MANDATORY! These actions should be performed as specified. Failure to perform mandatory actions can cause personal injury and/or equipment damage. On the product, this icon is represented as a white symbol on a blue dot with a white border.



PROHIBITED! These actions are prohibited. These actions should not be performed at any time or in any circumstances. Performing a prohibited action can cause personal injury and/or equipment damage. On the product, this icon is represented as a black symbol with a red circle and red slash.

Quick Reference Information

Authorized Pride Provider: _____

Address: _____

Phone Number: _____

Purchase Date: _____

NOTE: This owner's manual is compiled from the latest specifications and product information available at the time of publication. We reserve the right to make changes as they become necessary. Any changes to our products may cause slight variations between the illustrations and explanations in this manual and the product you have purchased. The latest/current version of this manual is available on our website.



Copyright © 2007
Pride Mobility Products Corp.
INFMANU3537/Rev A/March 07

C O N T E N T S

I. INTRODUCTION.....	4
II. SAFETY	6
III. YOUR POWER CHAIR	14
IV. ASSEMBLY.....	19
V. DISASSEMBLY	20
VI. COMFORT ADJUSTMENTS.....	23
VII. OPERATION	28
VIII. BATTERIES AND CHARGING.....	32
IX. CARE AND MAINTENANCE	36
X. WARRANTY	41

I . I N T R O D U C T I O N

SAFETY

WELCOME to Pride Mobility Products Corporation (Pride). The power chair you have purchased combines state-of-the-art components with **safety**, comfort, and styling in mind. We are confident that these design features will provide you with the conveniences you expect during your daily activities. Once you understand how to **safely** operate and care for your power chair, it should give you years of trouble free operation and service.

Read and follow all instructions, warnings, and notes in this manual before attempting to operate your power chair for the first time. In addition, your **safety** depends upon you, as well as your provider, caretaker, or healthcare professional in using good judgement.

If there is any information in this manual which you do not understand, or if you require additional assistance for setup or operation, please contact your authorized Pride Provider. **Failure to follow the instructions in this manual and those located on your power chair can lead to personal injury and/or damage to the power chair, and may void the warranty.**

PURCHASER'S AGREEMENT

By accepting delivery of this product, you promise that you will not change, alter, or modify this product or remove or render inoperable or unsafe any guards, shields, or other safety features of this product; fail, refuse, or neglect to install any retrofit kits from time to time provided by Pride to enhance or preserve the safe use of this product.

SHIPPING AND DELIVERY

Before using your power chair, make sure your delivery is complete as some components may be individually packaged. If you do not receive a complete delivery, please contact your authorized Pride Provider immediately. Where damage has occurred during transport, either to the packaging or content, please contact the delivery company responsible.

INFORMATION EXCHANGE

We want to hear your questions, comments, and suggestions about this manual. We would also like to hear about the safety and reliability of your new power chair, and about the service you received from your authorized Pride Provider.

Please notify us of any change of address, so we can keep you apprised of important information about safety, new products, and new options that can increase your ability to use and enjoy your power chair. Please feel free to contact us at the address below:

USA:

Pride Mobility Products Corporation
Attn.: Customer Care Department
182 Susquehanna Avenue
Exeter, PA 18643-2694
customercare@pridemobility.com
800-424-8205

Canada:

Pride Mobility Products Company
380 Vansickle Road Unit 350
St. Catharines, Ontario L2R 6P7
1-888-570-1113

NOTE: If you ever lose or misplace your product registration card or your copy of this manual, contact us and we will be glad to send you a new one immediately.

I . I N T R O D U C T I O N

PRIDE OWNERS CLUB

As an owner of a Pride product, you are encouraged to enroll in the Pride Owners Club. Complete and return your enclosed product registration card or visit Pride's web site at www.pridemobility.com.

From our home page, select "Owners Club" to enter a page dedicated to current and potential Pride product owners. You will gain access to interviews, stories, recreation ideas, daily living tips, product and funding information, and interactive message boards. These message boards invite you to communicate with other Pride customers as well as Pride representatives who are available to assist you with any questions or concerns you may have.

II. SAFETY

GENERAL GUIDELINES



MANDATORY! Do not operate your new power chair for the first time without completely reading and understanding this owner's manual.

Your power chair is a state-of-the-art life-enhancement device designed to increase mobility. Pride provides an extensive variety of products to best fit the individual needs of the power chair user. Please be aware that the final selection and purchasing decision regarding the type of power chair to be used is the responsibility of the power chair user, who is capable of making such a decision, and his/her healthcare professional (i.e., medical doctor, physical therapist, etc.).

The contents of this manual are based on the expectation that a mobility device expert has properly fitted the power chair to the user and has assisted the prescribing healthcare professional and/or the authorized Pride Provider in the instruction process for the use of the product.

There are certain situations, including some medical conditions, where the power chair user will need to practice operating the power chair in the presence of a trained attendant. A trained attendant can be defined as a family member or care professional specially trained in assisting a power chair user in various daily living activities.

As you begin using your power chair during daily activities, you will probably encounter situations in which you will need some practice. Simply take your time and you will soon be in full and confident control as you maneuver through doorways, on and off of elevators, up and down ramps, and over moderate terrain.

Below are some precautions, tips, and other safety considerations that will help you become accustomed to operating your power chair safely.

Modifications

Pride has designed and engineered your power chair to provide maximum mobility and utility. A wide range of accessories is available from your authorized Pride Provider to further customize your power chair to better suit your needs and/or preferences. However, under no circumstances should you modify, add, remove, or disable any feature, part, or function of your power chair.



WARNING! Do not modify your power chair in any way not authorized by Pride. Do not use accessories if they have not been tested or approved for Pride products.

Pre-Ride Safety Check

Get to know the feel of your power chair and its capabilities. Pride recommends that you perform a safety check before each use to make sure your power chair operates smoothly and safely.

Perform the following inspections prior to using your power chair:

- Check for proper tire inflation. Maintain but do not exceed **35 psi (2.4 bar)** in each tire if equipped with pneumatic tires.
- Check all electrical connections. Make sure they are tight and not corroded.
- Check all controller connections to the power base. Make sure they are secured properly.
- Check the brakes. See IX. "Care and Maintenance."
- Check battery charge. See VIII. "Batteries and Charging."

NOTE: *If you discover a problem, contact your authorized Pride Provider for assistance.*

II. SAFETY

Weight Limitations

Your power chair is rated for a maximum weight capacity. Please refer to the specifications table for this limit.



WARNING! Stay within the specified weight capacity of your power chair. Exceeding the weight capacity voids your warranty. Pride will not be held responsible for injuries and/or property damage resulting from failure to observe weight limitations.

WARNING! Do not carry passengers on your power chair. Carrying passengers on your power chair may affect the center of gravity, resulting in a tip or a fall.

Tire Inflation

If your power chair is equipped with pneumatic tires, you should check or have the air pressure checked regularly. Proper inflation pressures will prolong the life of your tires and help ensure the smooth operation of your power chair.



WARNING! It is important that 35 psi (2.4 bar) tire pressure be maintained in pneumatic tires at all times. Do not underinflate or overinflate your tires. Low pressure may result in loss of control, and overinflated tires may burst. Failure to maintain 35 psi (2.4 bar) tire pressure in pneumatic tires at all times may result in tire and/or wheel failure.

WARNING! Inflate your power chair drive tires from a regulated air source with an available pressure gauge. Inflating your tires from an unregulated air source could overinflate them, resulting in a burst tire.

Incline Information

More and more buildings have ramps with specified degrees of inclination, designed for easy and safe access. Some ramps may have turning switchbacks (180-degree turns) that require you to have good cornering skills on your power chair.

- Proceed with extreme caution as you approach the downgrade of a ramp or other incline.
- Take wide swings with your power chair's front wheels around any tight corners. If you do that, the power chair's rear wheels will follow a wide arc, not cut the corner short, and not bump into or get hung up on any railing corners.
- When driving down a ramp, keep the power chair's speed adjustment set to the slowest speed setting to ensure a safely controlled descent.
- Avoid sudden stops and starts.

When climbing an incline, try to keep your power chair moving. If you must stop, start up again slowly and then accelerate cautiously. When driving down an incline, set your power chair to the slowest speed setting and drive in the forward direction only. If your power chair starts to move down the incline faster than you anticipated or desired, allow it to come to a complete stop by releasing the joystick, then push the joystick forward slightly to ensure a safely controlled descent.

WARNING! When on any sort of an incline or decline, never place the power chair in freewheel mode while seated on it or standing next to it.

WARNING! When climbing an incline, do not zigzag or drive at an angle up the face of the incline. Drive your power chair straight up the incline. This greatly reduces the possibility of a tip or a fall. Always exercise extreme caution when negotiating an incline.



WARNING! You should not travel up or down a potentially hazardous incline (i.e., areas covered with snow, ice, cut grass, or wet leaves).

WARNING! Never travel down an incline backward. Doing so may cause the power chair to tip. Always exercise extreme caution when negotiating an incline.

WARNING! If your power chair is equipped with a reclining seatback, do not attempt to negotiate inclines with the seat in a reclined position. Do not attempt to negotiate obstacles with the seat in a reclined position unless an attendant is present to help stabilize the chair. Failure to heed could result in the power chair tipping over.

II. SAFETY



WARNING! Even though your power chair is capable of climbing slopes greater than those illustrated in figure 1, do not, under any circumstances, exceed the incline guidelines or any other specifications presented in this manual. Doing so could cause instability in your power chair.

In compliance with the Americans with Disabilities Act of 1990, all handicap public access ramps are required to have a maximum slope of 5° (8.7%). Therefore, Pride recommends that the maximum slope of an incline you attempt to safely ascend or descend on your power chair does not exceed 5° (8.7%). See figure 1.



WARNING! Any attempt to climb or descend a slope steeper than 5° (8.7%) may put your power chair in an unstable position and cause it to tip.

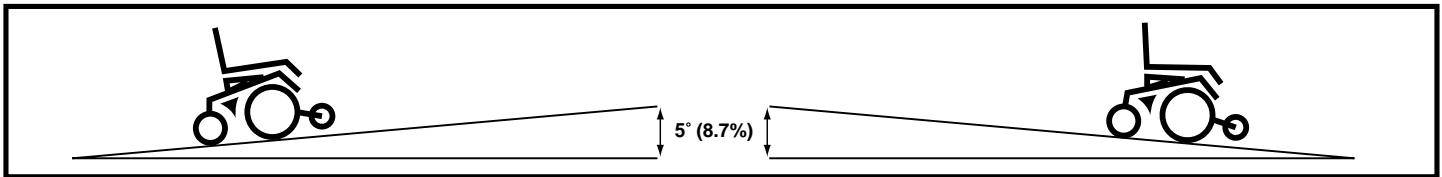

Figure 1. Maximum Safe Angle (Ascending and Descending)

Freewheel Mode

Your power chair is equipped with two manual freewheel levers to allow for manual maneuverability by a trained attendant. For more information about how to place your power chair into and out of freewheel mode, see III. “Your Power Chair.”

WARNING! Do not use your power chair in freewheel mode without an attendant present.



WARNING! Do not attempt to personally place your power chair in freewheel mode while seated on it. Ask an attendant for assistance if necessary.

WARNING! Do not place your power chair in freewheel mode while on an incline or decline. This could cause the chair to roll uncontrollably on its own.

Braking Information

Your power chair is equipped with two powerful brake systems:

- Regenerative — uses electricity to rapidly slow the vehicle when the joystick returns to the center/stop position.
- Disc Park Brake — activates mechanically after regenerative braking slows the vehicle to near stop, or when power is removed from the system for any reason.

Cornering Information

While your power chair is equipped rear caster wheels and front anti-tip wheels, excessively high cornering speeds can still create the possibility of tipping. Factors which affect the possibility of tipping include, but are not limited to: cornering speed, steering angle (how sharply you are turning), uneven road surfaces, inclined road surfaces, riding from an area of low traction to an area of high traction (such as passing from a grassy area to a paved area – especially at high speed while turning), and abrupt directional changes. High cornering speeds are not recommended. If you feel that you may tip over in a corner, reduce your speed and steering angle (i.e., lessen the sharpness of the turn) to prevent your power chair from tipping.



WARNING! When cornering sharply, reduce your speed and maintain a stable center of gravity. This greatly reduces the possibility of a tip or fall.

II. SAFETY

Public Streets and Roadways



WARNING! You should not operate your power chair on public streets and roadways. Be aware that it may be difficult for traffic to see you when you are seated on your power chair. Obey all local pedestrian traffic rules. Wait until your path is clear of traffic, and then proceed with extreme caution.

Outdoor Driving Surfaces

Your power chair is designed to provide optimum stability under normal driving conditions—dry, level surfaces composed of concrete, blacktop, or asphalt. However, Pride recognizes that there will be times when you will encounter other surface types. For this reason, your power chair is designed to perform admirably on packed soil, grass, and gravel. Feel free to use your power chair safely on lawns and in park areas.

- Reduce your power chair's speed when driving on uneven terrain and/or soft surfaces.
- Avoid tall grass that can entangle the running gear.
- Avoid loosely packed gravel and sand.
- If you feel unsure about a driving surface, avoid that surface.

Inclement Weather Precautions

Exposure of your power chair to inclement weather conditions should be avoided whenever possible. If suddenly caught up in rain, snow, severe cold or heat while operating your power chair, proceed to shelter at the earliest opportunity. Thoroughly dry your power chair before storing, charging, or operating your power chair.

WARNING! Operating in rain, snow, salt, mist/spray conditions, and on icy/slippery surfaces can have an adverse affect on the electrical system. Maintain and store your power chair in a dry and clean condition.



WARNING! Prolonged exposure to hot or cold conditions may affect the temperature of upholstered and non-upholstered items on the power chair, possibly resulting in skin irritation. Exercise caution when using the power chair in extremely hot or cold conditions or when exposing your power chair to direct sunlight for prolonged periods of time.

Stationary Obstacles (Steps, Curbs, etc.)

Proceed with extreme caution when driving near raised surfaces, unprotected ledges and/or drop-offs (curbs, porches, stairs, etc.). Be sure your power chair is traveling perpendicular to any curb you may be required to navigate. See figure 2.

WARNING! Do not attempt to have your power chair climb or descend an obstacle that is higher than 2 in. (5 cm) unless you have the assistance of an attendant.



WARNING! Do not attempt to have your power chair proceed backward down any step, curb, or other obstacle. This may cause the power chair to tip.

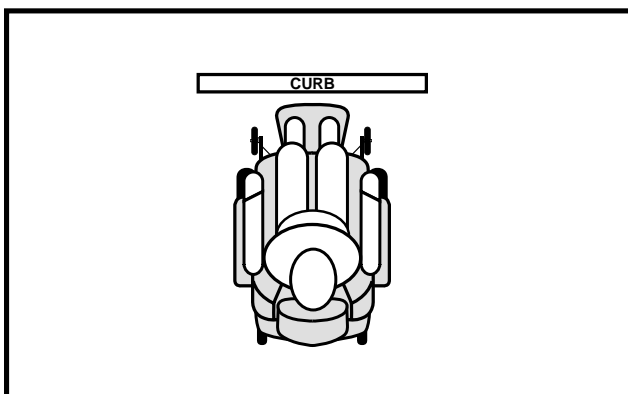

Figure 2. Correct Curb Approach

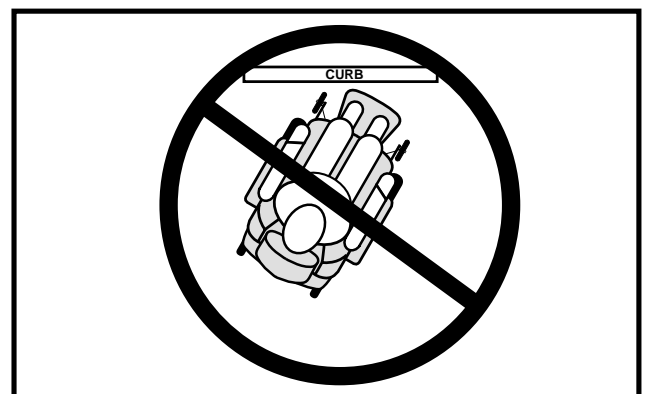

Figure 3. Incorrect Curb Approach

II. SAFETY

Stairs and Escalators

Power chairs are not designed to travel up or down stairs or escalators. Always use an elevator.



WARNING! Never use your power chair to negotiate steps or escalators.

Doors

- Determine if the door opens toward or away from you.
- Drive your power chair gently and slowly forward to push the door open. Or drive your power chair gently and slowly backward to pull the door open.

Elevators

Modern elevators have a door edge safety mechanism that, when pushed, reopens the elevator door(s).

- If you are in the doorway of an elevator when the door(s) begin to close, push on the rubber door edge or allow the rubber door edge to contact the power chair and the door will reopen.
- Use care that pocketbooks, packages, or power chair accessories do not become caught in elevator doors.

Lift/Elevation Products

If you will be traveling with your power chair, you may find it necessary to use a lift/elevation product to aid in transportation. Pride recommends that you closely review the instructions, specifications, and safety information set forth by the manufacturer of the lift/elevation product before using that product.



WARNING! Never sit on your power chair when it is being used in connection with any type of lift/elevation product. Your power chair was not designed with such use in mind and any damage or injury incurred from such use is not the responsibility of Pride.

Motor Vehicle Transport

Pride recommends that you do not remain seated in your power chair while traveling in a motor vehicle. The power chair should be stowed in the trunk of a car or in the back of a truck or van with batteries removed and properly secured.

WARNING! Do not sit on your power chair while it is in a moving vehicle.



WARNING! Always be sure your power chair and its batteries are properly secured when it is being transported. Batteries should be secured in an upright position and protective caps should be installed on the battery terminals. Batteries should not be transported with any flammable or combustible items.

Positioning Belts

Your authorized Pride Provider, therapist(s), and other healthcare professionals are responsible for determining your requirement for a positioning belt in order to operate your power chair safely.



WARNING! If you require a positioning belt to safely operate your power chair, make sure it is fastened securely in order to reduce the possibility of a fall from the power chair.

WARNING! The positioning belt is not designed for use as a seat belt in a motor vehicle. Nor is your power chair suitable for use as a seat in any vehicle. Anyone traveling in a vehicle should be properly belted into seats approved by the vehicle manufacturer.

II. SAFETY

Batteries

In addition to following the warnings below, be sure to comply with all other battery handling information. For more information about your power chair's batteries, see VIII. "Batteries and Charging."

WARNING! Power chair batteries are heavy. See specifications table. If you are unable to lift that much weight, be sure to get help. Use proper lifting techniques and avoid lifting beyond your capacity.



WARNING! Battery posts, terminals, and related accessories contain lead and lead compounds. Wear goggles and gloves when handling batteries and wash hands after handling.

WARNING! Always protect the batteries from freezing and never charge a frozen battery. Charging a frozen battery may result in damage to the battery.

WARNING! Connect the battery harnesses in the proper manner. RED (+) cables must be connected to positive (+) battery terminals/posts. BLACK (-) cables must be connected to negative (-) battery terminals/posts. Protective caps should be installed over all battery terminals. REPLACE cables immediately if damaged.

Removable Parts



WARNING! Do not attempt to lift or move a power chair by any of its removable parts, including the armrests, seat, foot riggings, controller, and shrouds.

Preventing Unintended Movement



WARNING! If you anticipate being seated in a stationary position for an extended period of time, turn off the power. This will prevent unexpected motion from inadvertent joystick contact. This will also eliminate the possibility of unintended chair movement from electromagnetic (EM) sources.

Reaching and Bending

Never reach, lean, or bend while driving your power chair. If it is absolutely necessary to reach, lean, or bend while seated on your power chair, it is important to maintain a stable center of gravity and keep the power chair from tipping. Pride recommends that the power chair user determine his/her personal limitations and practice bending and reaching in the presence of a qualified healthcare professional.



WARNING! Do not bend, lean, or reach for objects if you have to pick them up from the floor by reaching down between your knees or if you have to reach over the back of the seat. Movements such as these may change your center of gravity and the weight distribution of the power chair. This may cause your power chair to tip.

WARNING! Keep your hands away from the tires when driving. Be aware that loose fitting clothing can become caught in drive tires.

II. SAFETY

Transfers

Transferring onto and off of your power chair requires a good sense of balance. Always have an attendant or health-care professional present while learning to properly transfer yourself.

To eliminate the possibility of injury, Pride recommends that you or a trained attendant perform the following tasks before attempting a transfer:

- Turn off the power to the controller.
- Ensure your power chair is not in freewheel mode. See III. “Your Power Chair.”
- Turn the caster wheels toward the transfer destination to improve power chair stability during transfer.
- Make sure both armrests are flipped up or removed from your power chair.
- Flip up the foot platform or move the leg rests aside; this will help to keep your feet from getting caught on the foot rigging during the transfer.
- Reduce the distance between your power chair and the object you are transferring onto.

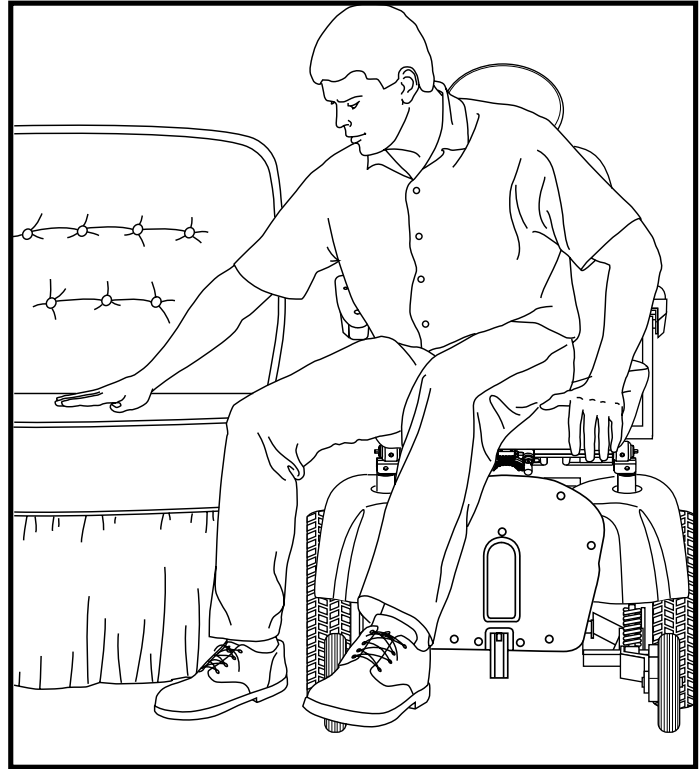

Figure 4. Ideal Transfer Position

WARNING! Before transferring, position yourself as far back as possible in the power chair seat to prevent the power chair from tipping forward during transfer.



WARNING! Avoid putting all of your weight on the power chair armrests and do not use the armrests for weight bearing purposes, such as transfers. Such use may cause the power chair to tip, resulting in a fall from the power chair.

WARNING! Avoid putting all of your weight on the foot riggings. Such use may cause the power chair to tip.

Prescription Drugs/Physical Limitations

Users must exercise care and common sense when operating a power chair. This includes awareness of safety issues when taking prescribed or over-the-counter drugs or when the user has specific physical limitations.



WARNING! Consult your physician if you are taking prescribed or over-the-counter medication or if you have certain physical limitations. Some medications and limitations may impair your ability to operate your power chair in a safe manner.

II. SAFETY

Alcohol/Smoking

The power chair user must exercise care and common sense when operating his/her power chair. This includes awareness of safety issues while under the influence of alcohol or while smoking.

WARNING! Do not operate your power chair while you are under the influence of alcohol, as this may impair your ability to operate your power chair in a safe manner.



WARNING! Pride strongly recommends that you do not smoke cigarettes while seated in your power chair, although the power chair has passed the necessary testing requirements for cigarette smoking. You must adhere to the following safety guidelines if you decide to smoke cigarettes while seated in your power chair.

- Do not leave lit cigarettes unattended.
- Keep ashtrays a safe distance from the seat cushions.
- Always make sure cigarettes are completely extinguished before disposal.

Electromagnetic and Radio Frequency Interference (EMI/RFI)



WARNING! Laboratory tests have shown that electromagnetic and radio frequency waves can have an adverse affect on the performance of electrically-powered mobility vehicles.

Electromagnetic and Radio Frequency Interference can come from sources such as cellular phones, mobile two-way radios (such as walkie-talkies), radio stations, TV stations, amateur radio (HAM) transmitters, wireless computer links, microwave signals, paging transmitters, and medium-range mobile transceivers used by emergency vehicles. In some cases, these waves can cause unintended movement or damage to the control system. Every electrically-powered mobility vehicle has an immunity (or resistance) to EMI. The higher the immunity level, the greater the protection against EMI. This product has been tested and has passed at an immunity level of 20 V/m.

WARNING! Be aware that cell phones, two-way radios, laptops, and other types of radio transmitters may cause unintended movement of your electrically-powered mobility vehicle due to EMI. Exercise caution when using any of these items while operating your mobility vehicle and avoid coming into close proximity of radio and TV stations.



WARNING! The addition of accessories or components to the electrically-powered mobility vehicle can increase the susceptibility of the vehicle to EMI. Do not modify your power chair in any way not authorized by Pride.

WARNING! The electrically-powered mobility vehicle itself can disturb the performance of other electrical devices located nearby, such as alarm systems.

NOTE: For further information on EMI/RFI, go to the Resource Center on www.pridemobility.com. If unintended motion or brake release occurs, turn your power chair off as soon as it is safe to do so. Call Pride at 800-424-8205 to report the incident.

III. YOUR POWER CHAIR

THE JAZZY 100

Your power chair has two main assemblies: the seat and the power base. See figure 5. Typically, the seating system includes the armrests, the seatback, the seat base, and the controller. The power base assembly includes two drive wheels, two anti-tip wheels, two rear caster wheels, a body shroud, four frame assemblies (located under the body shroud), two battery boxes, and the electrical connectors. See figures 5, 6, and 7.

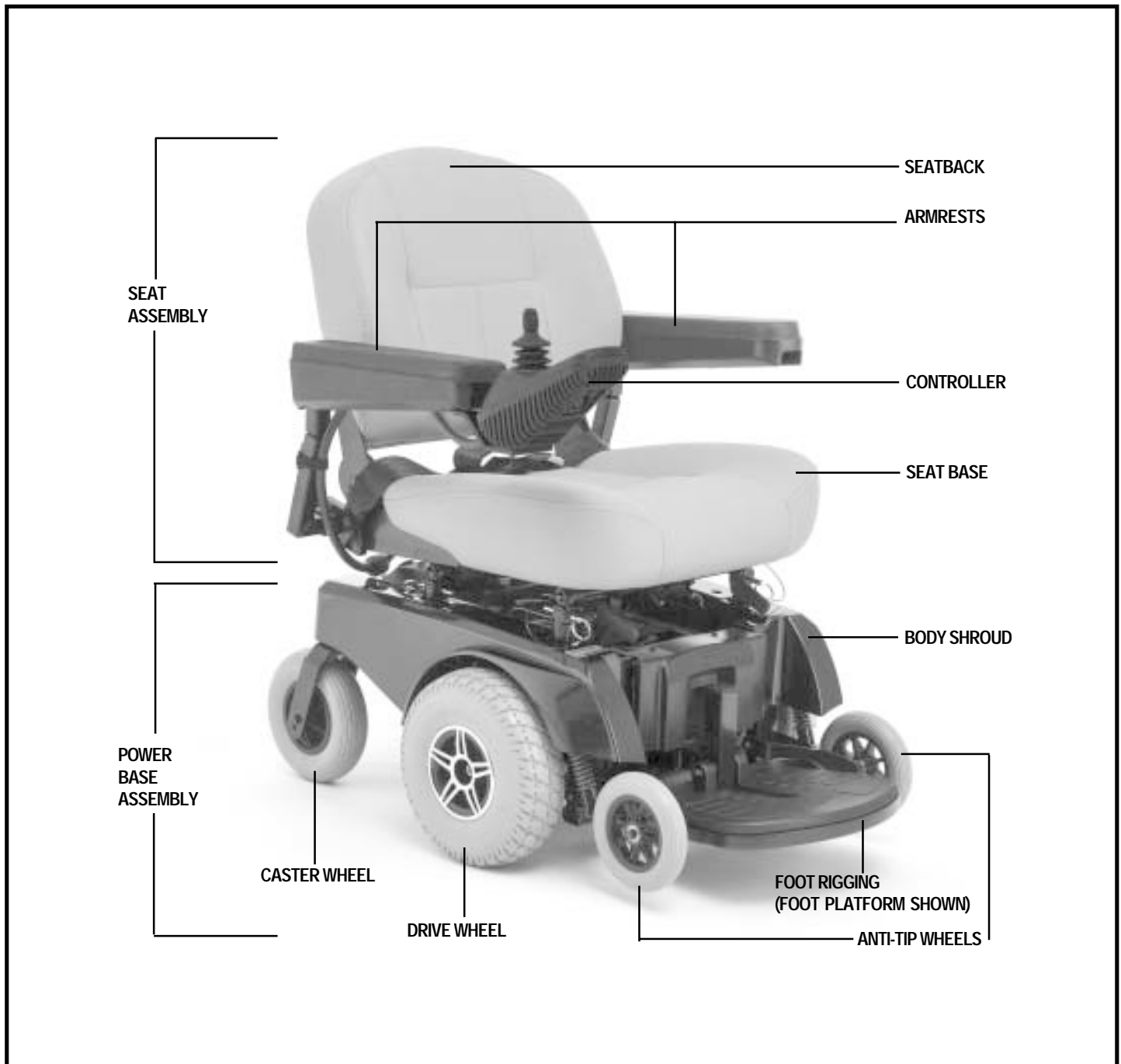

Figure 5. The Jazzy 100

III. YOUR POWER CHAIR

Specifications	
Suspension:	Limited
Drive Wheels:	10 in.(25.4 cm), solid, center-mounted
Caster Wheels:	8 in. (20.32 cm), solid, rear articulating
Anti-Tip Wheels:	6 in. (15.24 cm), solid, front mounted
Maximum Speed: ¹	Up to 4 mph (6.43 km/h)
Range: ¹	Up to 14 miles (22.53 km)
Brakes:	“Intelligent Braking,” electronic regenerative, disc park brake
Ground Clearance: ²	2.0 in. (5 cm)
Turning Radius: ²	18.5 in.(47 cm)
Overall Size: ²	Length: 32.5 in. (82.5 cm) Width: 23 in. (58.42 cm) assembled
Drivetrain:	Two motor, mid-wheel
Batteries: ³	Two 12-volt, deep-cycle U-1 batteries
Battery Charger:	4-amp, Onboard
Weight Capacity:	300 lbs. (136 kg)
Component Weights:	Seat: 33 lbs. (14.97 kg) Foot Platform: 8.5 lbs. (3.85 kg) Front Battery and Case: 26 lbs. (11.79 kg) (<i>U-1 Battery: 24.5 lbs. (11.11 kg)</i>) Rear Battery and Case: 26 lbs. (11.79 kg) (<i>U-1 Battery: 24.5 lbs. (11.11 kg)</i>) Battery Well Frame: 13.5 lbs. (6.12 kg) Front Frame: 2.5 lbs. (1.13 kg) Right Frame Assembly: 38 lbs. (17.23 kg) Left Frame Assembly: 38 lbs. (17.23 kg)

- ¹ Varies with base model, user weight, terrain type, battery amp hour rating (Ah), battery charge, battery condition, motors, controller type, tire type, and tire condition.
- ² Due to manufacturing tolerances and continued product improvement, this specification can be subject to variance of (+ or -) 3%.
- ³ AGM or Gel-Cell type required. See VIII. “Batteries and Charging.”

NOTE: All specifications subject to change without notice.

III. YOUR POWER CHAIR

Electrical Components

The electrical components consist of the controller, the batteries, and the motors. The batteries, motors, and controller power module (if equipped) are located on the power base assembly. The controller is located on the seat assembly. Connectivity between the controller and the motors, batteries, and the battery charger is provided by one or more wiring harnesses. See figures 6 and 7.

Controller Connector: This is where the controller connects to the power base. Each controller uses a different type of cable. Regardless of which type of controller is used, the cable must be secured to the seat assembly and not allowed to drag on the floor.

Ammeter: This displays the charger's current output in amps.

Main Circuit Breaker: This is a safety feature built into your power chair. When the batteries and the motors are heavily strained (e.g., from excessive loads), the main circuit breaker trips to prevent damage to the motors and the electronics. If the circuit trips, allow the power chair to "rest" for approximately one minute. Then, push in the circuit breaker button, turn on the controller, and continue normal operation. If the main circuit breaker continues to trip repeatedly, contact your authorized Pride Provider.

Charger Power Cord Receptacle: This is where the charger power cord plugs in when the batteries need to be re-charged.

Battery Connectors (Quick-Connectors): These provide a connection between the battery boxes and the power base.

Motor Connectors: These provide a connection between the motors and the power base.

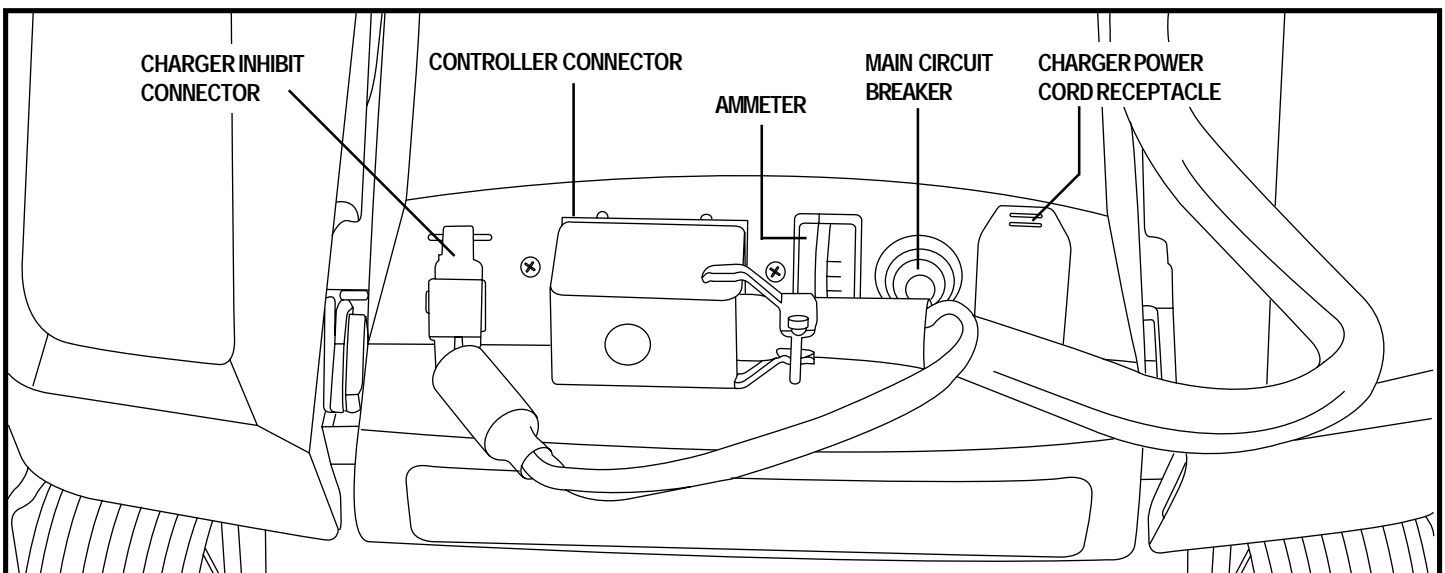

Figure 6. Electronics Tray

III. YOUR POWER CHAIR

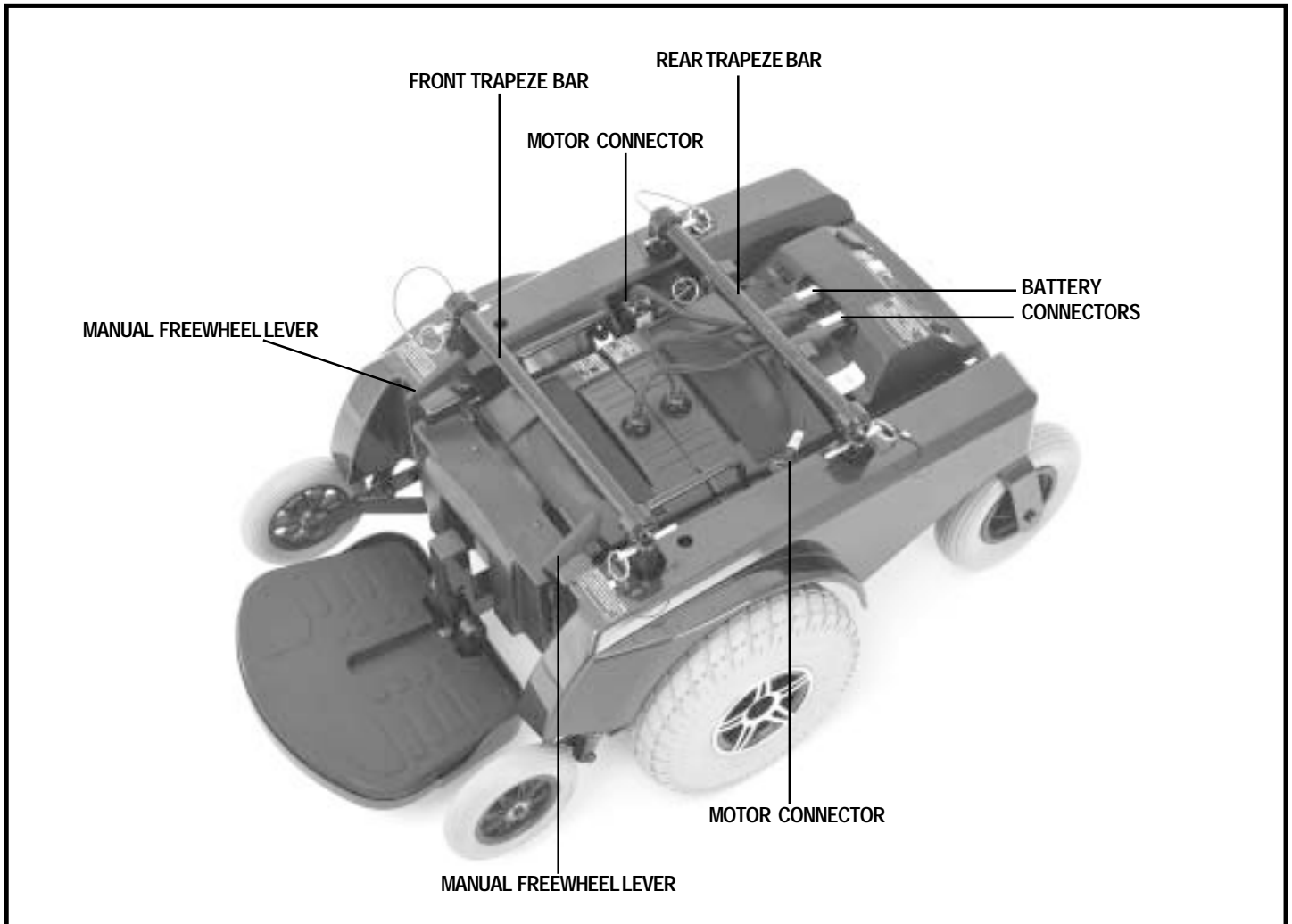

Figure 7. Power Base Top View

Manual Freewheel Levers

For convenience, your power chair is equipped with two manual freewheel levers—one for each motor. See figures 8 and 9. These levers allow you to disengage the drive motors from the gearboxes and maneuver the chair manually. This is called freewheel mode.



WARNING! Do not use the power chair while the drive motors are disengaged! Do not disengage the drive motors when the power chair is on an incline or decline, as the unit could roll on its own. Only engage the freewheel mode when on a level surface.

WARNING! It is important to remember that when your power chair is in freewheel mode, the braking system is disengaged.

To engage or disengage the drive motors:

1. Rotate the manual freewheel levers inward to engage the drive motors and place your power chair in drive mode. See figure 8.
2. Rotate the manual freewheel levers outward to disengage the drive motors and place your power chair in freewheel mode. See figure 9.

III. YOUR POWER CHAIR

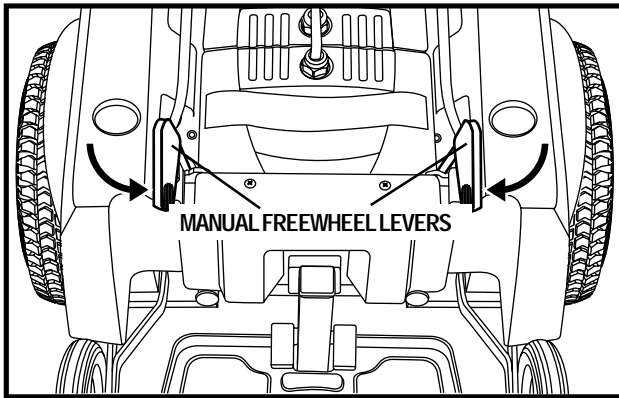

Figure 8. Drive Mode (Drive Engaged)

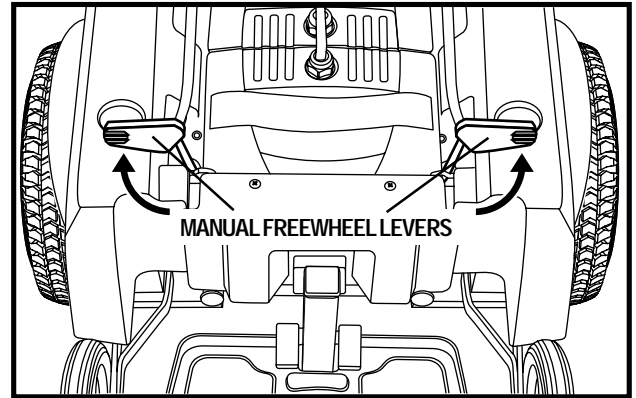

Figure 9. Freewheel Mode (Drive Disengaged)

NOTE: *If a lever is difficult to move in either direction, rock your power chair back and forth slightly. The lever should then move to the desired position.*



WARNING! Do not use the freewheel lever handles as tie-down points to secure this product.

IV. ASSEMBLY

INITIAL ASSEMBLY

Your power chair may require some assembly either before initial use or after transportation. It may also require disassembly to make some comfort adjustments.

NOTE: Any nylon insert lock nut removed during the disassembly or adjustment of the power chair must be replaced with a new nut. Nylon insert lock nuts should not be reused as it may cause damage to the nylon insert, resulting in a less secure fit. Replacement nylon insert lock nuts are available at local hardware stores or through your authorized Pride Provider.

Seat Installation

It may be necessary to install the seat either prior to initial operation or after transporting your power chair. Most seats are attached to the power base with the Universal Mounting System (UMS). The UMS consists of universal parts that may be attached to any medium-back or high-back seat, regardless of seat width or seat depth. The two main components are aluminum extrusions mounted to the seat base. These extrusions attach to a pair of trapeze bars that are mounted to the power base.



WARNING! Do not pick up the seat frame by the armrests. They are free to pivot, and you may lose control of the seat if they do so, resulting in personal injury or damage to the chair.

To install the seat:

1. Set the trapeze bars to the desired height. To change the trapeze bar height, see VI. “Comfort Adjustments.”
2. Tilt the seat back, and slide the rear extrusion onto the rear trapeze bar. See figure 10.
3. Lower the front extrusion onto the front trapeze bar until the seat locks into place.
4. Flip the seat latch safety down. See figure 11.



WARNING! Make sure the seat latch safety is flipped down before using your power chair.

5. Install the controller into one of the armrests. See VI. “Comfort Adjustments.”
6. Route the controller cable so that it cannot be pinched in the seat hinge and plug the cable into the controller connector on the electronics tray.
7. Secure the controller cable to the armrest receiver with one or more wire ties.

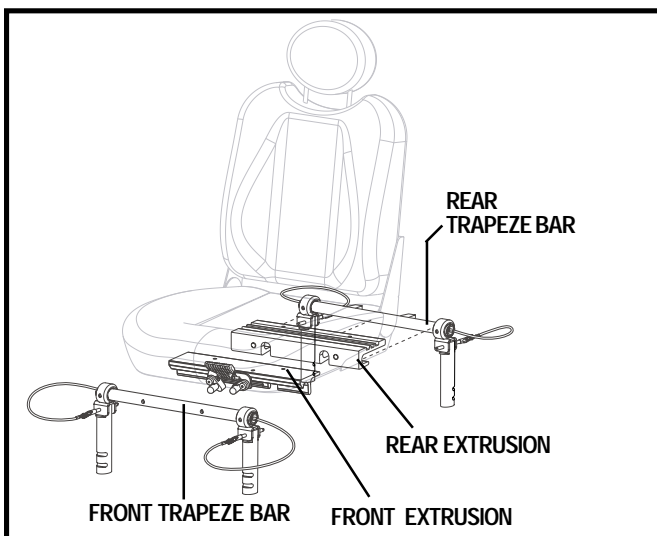

Figure 10. Universal Mounting System

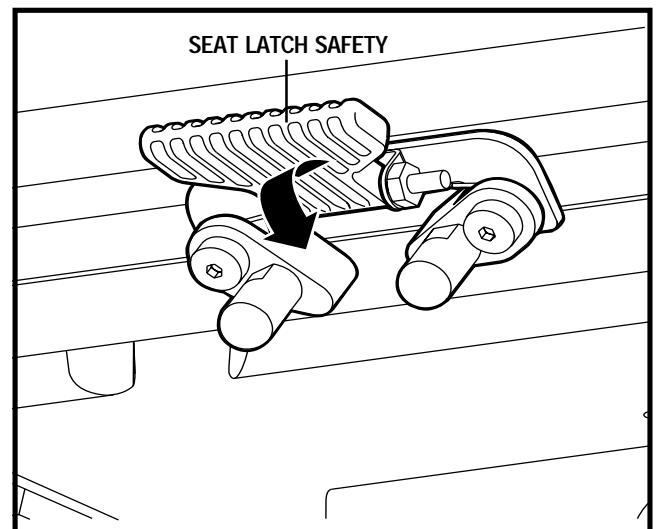

Figure 11. Seat Latch Safety

V. DISASSEMBLY

DISASSEMBLY

Your power chair disassembles into eight easily transportable component assemblies with no tools required. See figure 12. Place the power chair in an area where there is ample space to work and move around the unit—three or more feet of clearance on all sides. Make sure the unit is powered off before disassembling the chair.

WARNING! Even though no tools are required to disassemble or assemble your power chair, you should take care not to place your hands or fingers on the areas of the component assemblies where they may be pinched, as the assemblies “snap” together or “snap” apart.



WARNING! Some power chair components are heavy. You may need assistance to lift or carry them. Please refer to the specifications table for specific component weights before you disassemble the power chair.

NOTE: During both the disassembly and the assembly of your power chair, you may find it helpful to engage the drive motors to secure the unit from rolling. See III. “Your Power Chair.”

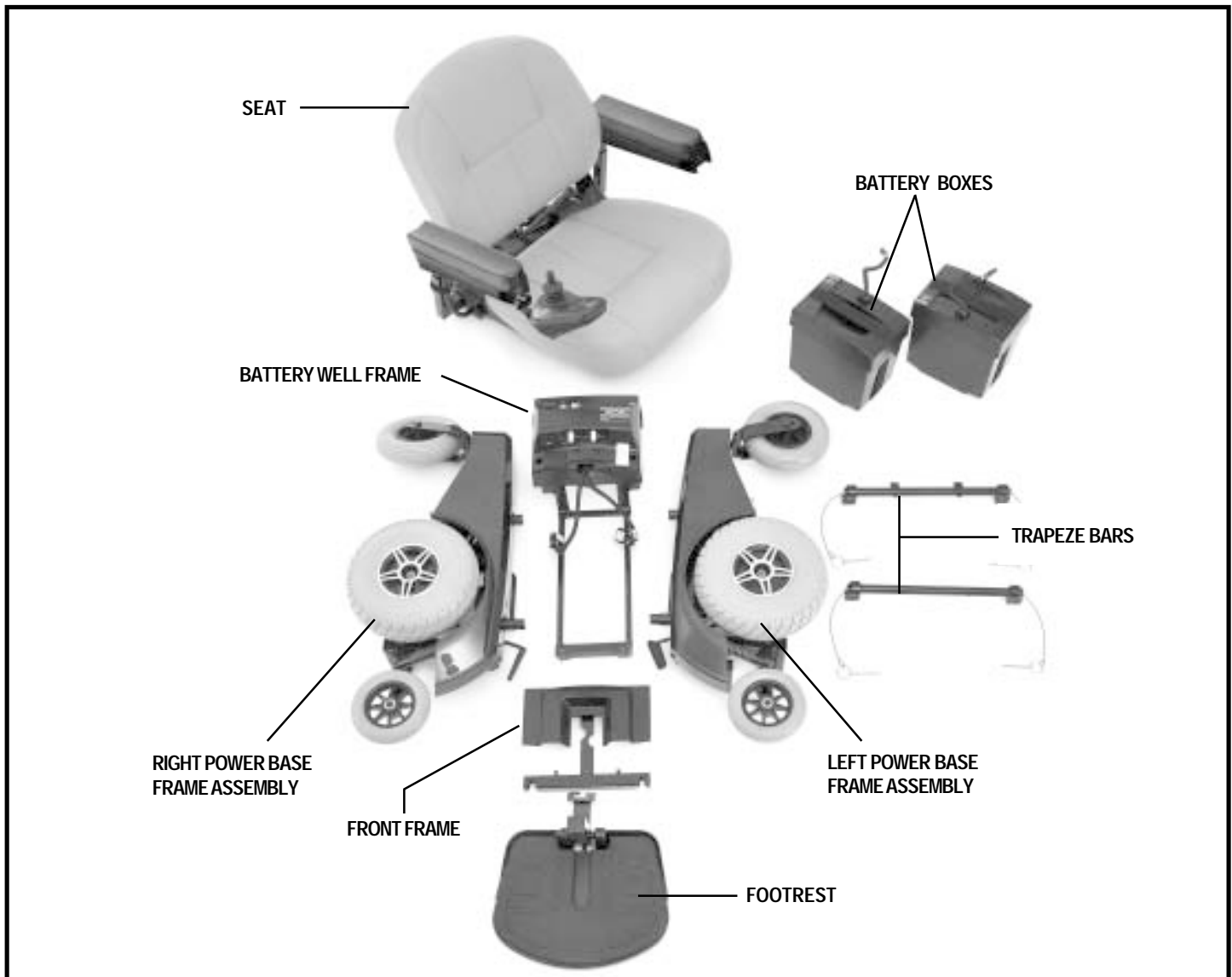

Figure 12. The Jazzy 100 Component Assemblies

V. DISASSEMBLY

To disassemble your power chair:

1. Turn off the power to the controller.
2. Disconnect the controller connector from the electronics tray. See figure 6.
3. Disconnect the charger inhibit connector from the electronics tray. See figure 6. Squeeze the latch release levers on the connector and pull it firmly from the socket.
4. Flip up the seat latch safety. See figure 13.
5. Squeeze the seat latch and release the seat from the front trapeze bar.
6. Slide the seat forward and remove it from the power base.
7. Remove the ball detent pins from the seat posts and remove the front and rear trapeze bars. See figure 14.
8. Remove the foot platform. Slide the mounting bracket up the vertical bar of the front frame until the tabs on the mounting bracket can be pulled forward through the matching slots in the front frame. See figure 15.
9. Disconnect the battery connectors and the motor connectors from the power base. See figure 6.
10. Lift and remove each battery box. See figure 16.
11. Remove the battery well frame. Squeeze together the latch release levers that hang vertically down from the crossbar at the rear of the battery well frame. See figure 17.
12. Lift up the battery well frame. Pull it to the rear of the chair to release the front slots from the locating pins on the front frame bottom bar. See figure 18.
13. Remove the left and right frame assemblies from the front frame. Stand behind the power chair and grasp the frame assembly handle on the side you wish to disassemble first. See figure 19.
14. Use your hand and thumb to hold the front frame and press and hold (toward the center of the front frame) the silver-colored latch release lever.
15. Hold the frame assembly with one hand and push the frame assembly outward.
16. Pull up on the front frame with your other hand until the latching mechanism releases.
17. Keep pulling upward with your hand until the locating pin on the bottom of that side of the front frame releases from its slot in the frame assembly. See figure 20.
18. Carefully let the frame assembly tilt to a resting position.

NOTE: Follow the disassembly procedure in the reverse order to assemble the unit.

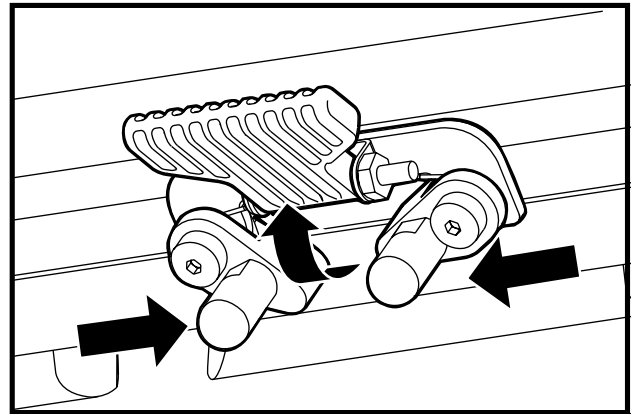

Figure 13. Seat Latch Safety

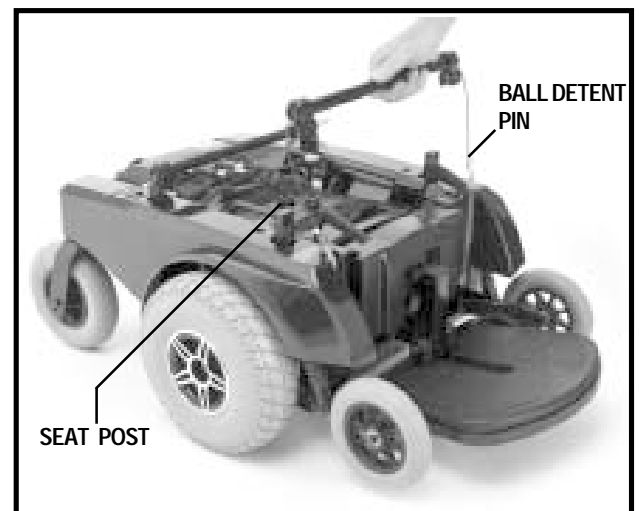

Figure 14. Removing the Trapeze Bars



Figure 15. Removing the Foot Platform

V. DISASSEMBLY



Figure 16. Removing Battery Boxes



Figure 17. Removing Battery Well Frame

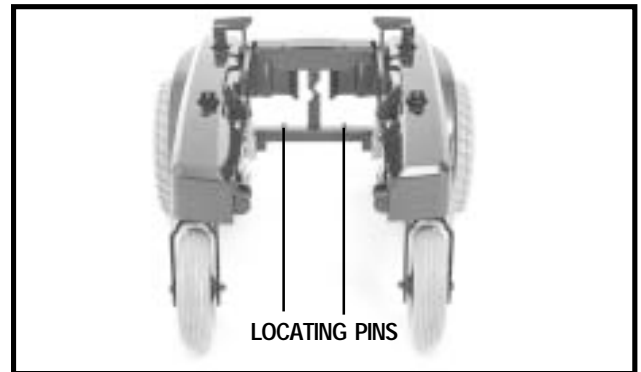

Figure 18. Battery Well Frame

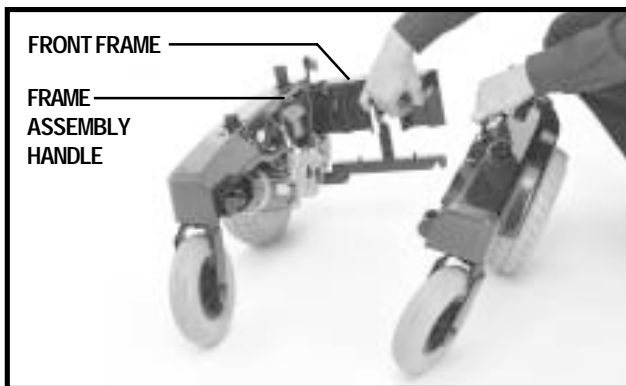

Figure 19. Removing Front Frame

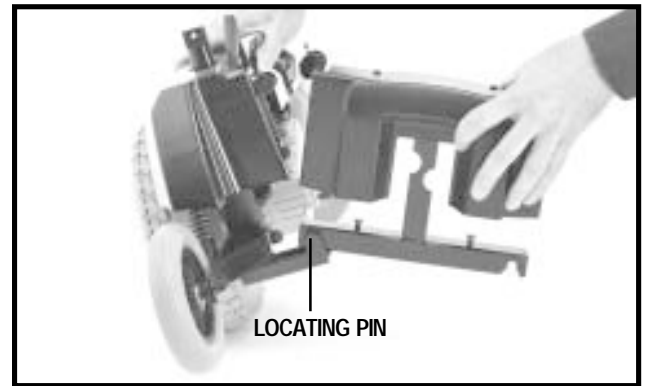

Figure 20. Front Frame Assembly

VI. COMFORT ADJUSTMENTS

COMFORT ADJUSTMENTS

After becoming familiar with your power chair's operation, you may find the need to make some adjustments to increase your comfort, such as seat height and angle, armrest angle, foot platform height and angle, and controller position.

NOTE: *If your power chair is equipped with a Specialty Seat, refer to the information in separate manuals. If your power chair is equipped with a contour seating system, refer to the following information.*

WARNING! If your power chair was configured by your authorized Pride Provider, please consult your healthcare professional before changing the seat position or making any other adjustment. Some adjustments may degrade your power chair's performance and safety by changing its center of gravity.



WARNING! Some power chair components are heavy. You may need assistance to lift or carry them. Please refer to the specifications table for specific component weights before you disassemble the power chair.

WARNING! Remove the occupant from the power chair before making any adjustments.

You may need the following to make comfort adjustments:

- metric/standard socket set and ratchet
- adjustable wrench
- metric/standard hex key set
- thread lock

Seat Height and Seat Angle Adjustment

You can change the seat height by either raising or lowering the four seat towers.

To change the seat height:

1. Turn off the power to the controller.
2. Unplug the controller connector from the power base.
3. Remove the quick-release pins that attach the trapeze bars to the seat towers. See figure 14.
4. Remove the seat.
5. Remove the battery harnesses.
6. Remove the battery boxes.
7. Remove the ball detent pin from each seat tower as shown in figure 21.
8. Raise or lower each seat tower to the desired position.
9. Install the ball detent pin into each seat tower.
10. Reinstall the battery boxes.
11. Reinstall the battery harnesses.
12. Reinstall the seat and secure the trapeze bars.
13. Plug the controller connector into the power base.

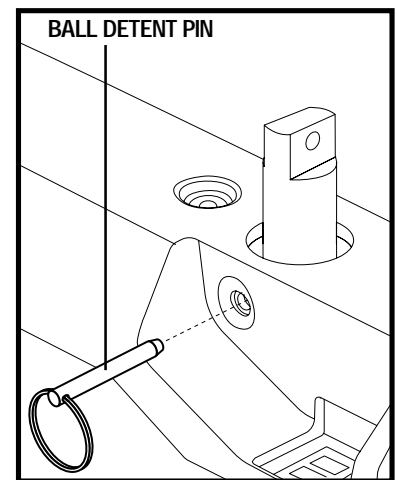

Figure 21. Seat Tower

To change the seat angle:

Raise or lower only one set of seat towers (front or rear).

VI. COMFORT ADJUSTMENTS

Seat Position

You can move the seat forward or rearward by changing the extrusion mounting position.

To change the seat position:

1. Turn off the power to the controller.
2. Unplug the controller connector from the power base.
3. Remove the seat from the power base.
4. Remove both extrusions from the bottom of the seat.
5. Reposition the extrusions on a different set of mounting holes.
You must move both extrusions the same number of holes either forward or backward. See figure 22.
6. Fasten the extrusions back onto the bottom of the seat.
7. Reinstall the seat.
8. Plug the controller connector into the power base.

Manual Recline Seatback Adjustment

If your power chair is equipped with an optional reclining seat, you can adjust the seatback angle with the seatback release lever. The lever is located on the right side of the seat base.

To adjust the seatback angle:

1. Pull up on the seatback release lever.
2. Move the seatback down or up to the desired position.
3. Release the lever.

Headrest Adjustment

If your power chair is equipped with the optional high-back seat with headrest, you can adjust the headrest height.

To adjust the headrest height:

1. Push in the headrest release button.
2. Move the headrest up or down to the desired position.

Seatback Angle Adjustment

If your power chair is equipped with an adjustable seatback, you can adjust it to four (4) different angles: 90°, 102°, 105°, or 107°.

To adjust the seatback angle:

1. Remove the seatback angle adjustment screws from both seat hinges. See figure 23.
2. Set the seatback at the desired angle.
3. Reinstall the screws to both seat hinges and tighten.

Armrest Width Adjustment

You can change each armrest's width independently of the other.

NOTE: *Changing the armrest width may increase the overall width of your power chair.*

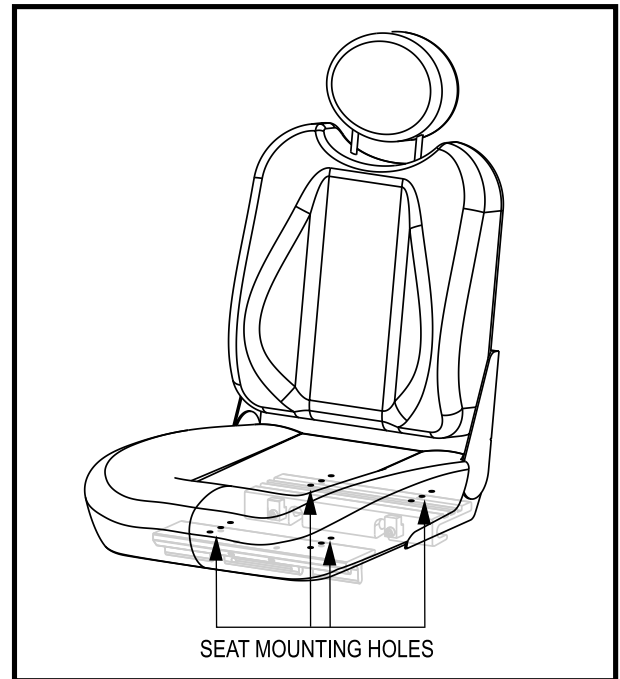

Figure 22. Seat Mounting Holes

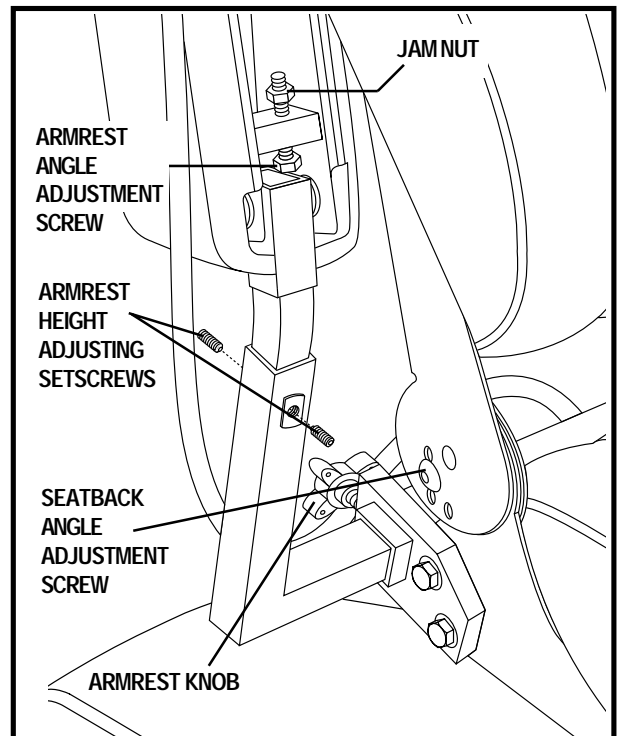

Figure 23. Seatback/Armrest Adjustment

VI. COMFORT ADJUSTMENTS

To change the armrest width:

1. Locate the two armrest knobs on each side of the armrest receiver bracket. See figure 23.
2. Loosen the knobs.
3. Slide the armrests in or out to the desired width.
4. Tighten the knobs.

Armrest Height Adjustment

To change the armrest height:

1. Loosen the two setscrews located on the armrest receiver. See figure 23.
2. Raise or lower the armrest to the desired height.
3. Tighten the setscrews to secure the armrest.

Armrest Angle Adjustment

To change the armrest angle:

1. Lift the armrest straight up so that it is perpendicular to the floor.
2. Loosen the jam nut. See figure 23.
3. Turn the adjustment screw to raise the front of the armrest or to lower the front of the armrest.
4. Tighten the jam nut to lock the adjustment screw into place.

Controller Position

You can move the controller in toward or out away from the armrest, or change the position the controller for either left-hand or right-hand use.



WARNING! Do not place the controller cable so that it can be pinched in the seat frame or the power base frame.

To extend the controller:

1. Flip up the armrest so it is perpendicular to the floor.
2. Loosen the setscrew on the controller bracket. See figure 24.
3. Slide the controller into or out of the armrest to the desired position.

To change the controller position:

1. Turn off the power to the controller.
2. Unplug the controller connector from the power base.
3. Cut any wire ties that attach the controller cable to the armrest.
4. Flip up the armrests and loosen the setscrews. See figure 24.
5. Slide the controller out of the armrest and place it in the other armrest.
6. Tighten the setscrews on the bottom of each armrest.
7. Use a wire tie to secure the controller cable to the armrest.
8. Plug the controller connector into the power base.

Foot Platform Height Adjustment

The foot platform height is easily adjusted to several different heights.

To raise or lower the foot platform:

1. Remove the mounting hardware from the foot platform. See figure 25.

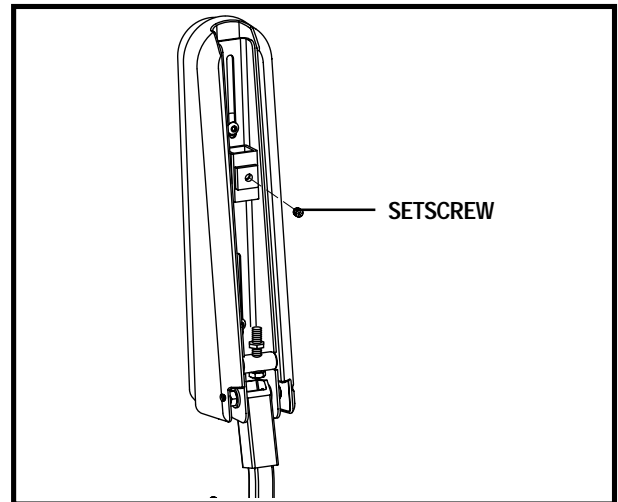

Figure 24. Underside of Armrest

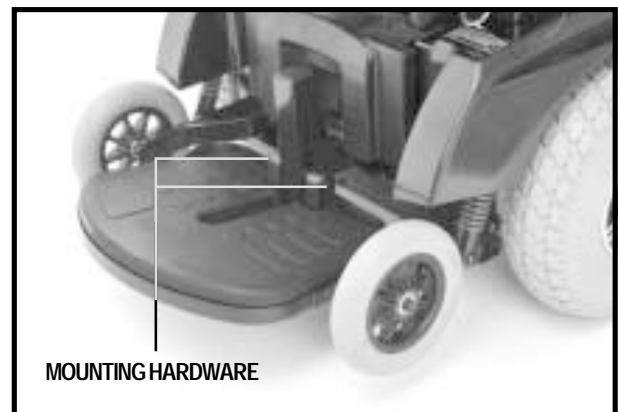

Figure 25. Foot Platform Height Adjustment

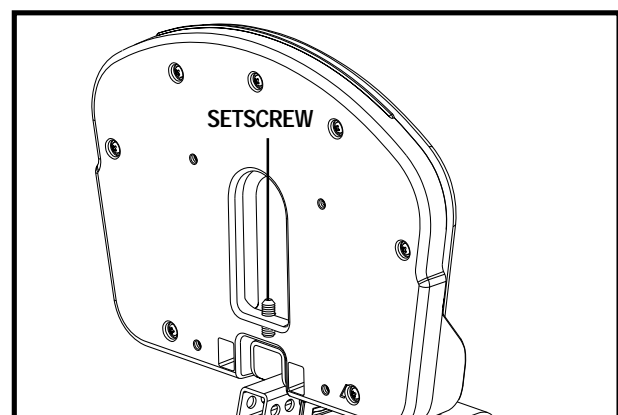

Figure 26. Foot Platform Angle Adjustment

VI. COMFORT ADJUSTMENTS

2. Raise or lower the foot platform to the desired height.
3. Reinstall the mounting hardware into the foot platform and tighten.

Foot Platform Angle Adjustment

To adjust the foot platform angle:

1. Flip up the foot platform and locate the setscrew. See figure 26.
2. Turn the setscrew to raise or lower the front of the foot platform.

Swing-Away Footrests

Swing-Away Footrests (SFRs) enable you to rotate the footrests to the side before you transfer onto or off of your power chair. See figure 27.

To rotate the SFRs:

1. Push in the release lever.
2. Rotate the SFRs.

To adjust the SFR length:

1. Remove the two adjustment screws from the back of each footrest extension.
2. Slide the footrest up or down to the desired length.
3. Reinstall the two adjustment screws.

Elevating Leg Rests

Elevating Leg Rests (ELRs) offer an infinite range of adjustment for the leg angle and a footrest adjustment range of 12–19 in. (30.48–48.26 cm). See figure 28.

To rotate the ELRs:

1. Push in release lever A.
2. Rotate the ELRs.

To adjust the ELR angle:

1. Push down release lever B.
2. Move the leg rest to the desired angle.

To adjust the ELR length:

1. Remove the two adjustment screws from the back of each leg rest extension.
2. Slide the leg rest up or down to the desired length.
3. Reinstall the two adjustment screws.

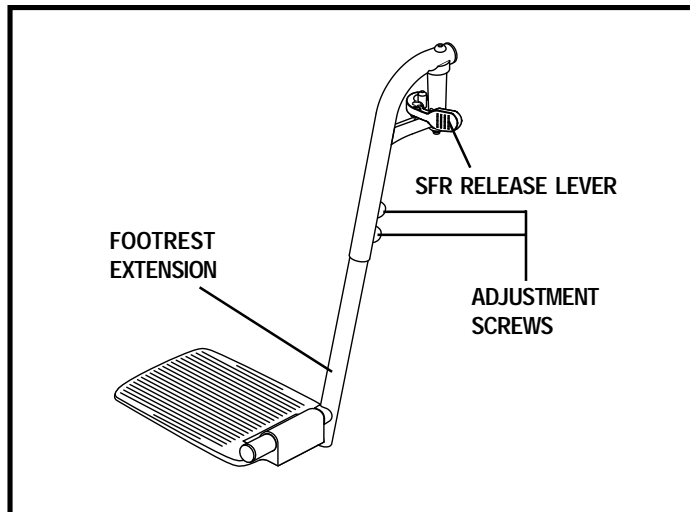

Figure 27. Swing-away Footrest Adjustment

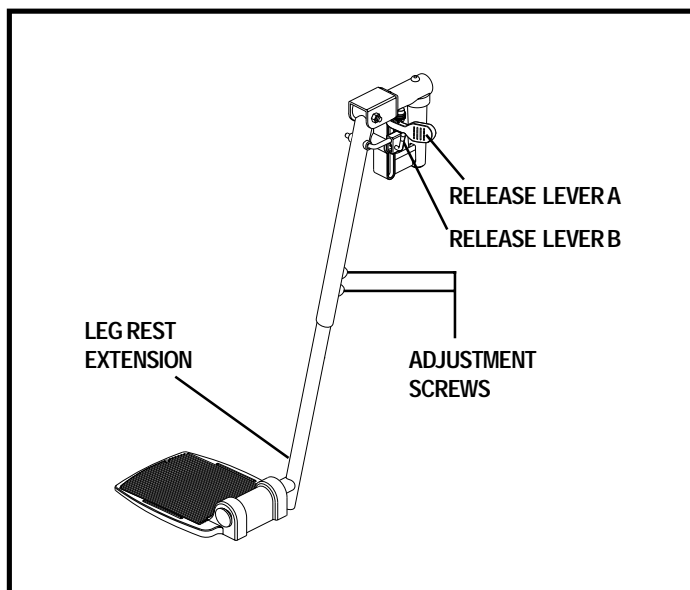

Figure 28. Elevating Leg Rests

VI. COMFORT ADJUSTMENTS

Anti-Tip Wheels Adjustment

The anti-tip wheels are designed to give your power chair increased stability on rough surfaces. The anti-tip wheels are preset at the factory for smooth surfaces or indoor use only. If you plan on using your power chair on rough surfaces, it may be necessary to adjust the anti-tip wheels to better suit your needs. The anti-tip wheels may need adjustment if the following occurs:

- When coming to a stop, your power chair tips forward excessively.
- The anti-tip wheels constantly rub the ground.

WARNING! Consult your authorized Pride Provider before attempting to change the anti-tip wheel height! Changing the anti-tip wheel height affects handling under acceleration!



WARNING! The higher you raise the anti-tip wheels, the more you increase your power chair's tendency to tilt forward while decelerating. You can compensate for this by having your authorized Pride Provider make a small adjustment to the pre-programmed deceleration setting in the controller or by moving the seat assembly farther to the back of your power chair.



PROHIBITED! Do not remove the anti-tip wheels.

NOTE: Each drive tire must be inflated to 35 psi (2.4 bar) if equipped with pneumatic tires.

To adjust the anti-tip wheels:

1. Turn off the power to the controller.
2. Make sure that the manual freewheel levers are in the drive position.
3. Disconnect the controller from the electronics tray.
4. Remove the seat.
5. Unplug the left and right motor connectors.
6. Unplug and remove both battery boxes.
7. Remove both left and right shrouds. Two screws fasten each shroud section to the frame. These screws are located on the top of the shroud near the seat post holes.
8. Locate the anti-tip adjustment nut. See figure 29.
9. Turn the adjustment nut counterclockwise to lower the anti-tip wheels and soften the suspension, or turn the adjustment nut clockwise to raise the anti-tip wheels and stiffen the suspension.

NOTE: Make the same adjustment to both anti-tip wheels.

10. Reinstall the left and right shrouds.
11. Reinstall both battery boxes and plug in the battery connectors.
12. Plug the left and right motor connectors into their receptacles.
13. Reinstall the seat.
14. Connect the controller to the electronics tray.

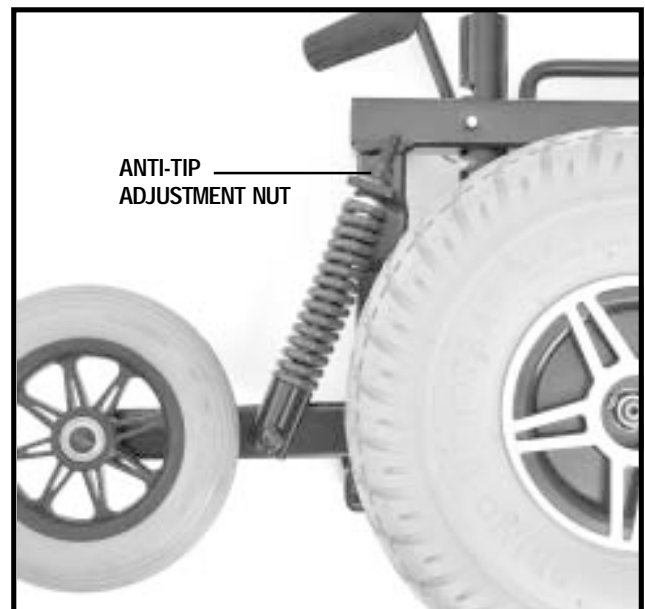

Figure 29. Anti-tip Wheel adjustment

VII. OPERATION

VSI ELECTRONIC CONTROLLER

The electronic controller is what you use to operate your power chair. The electronic controller enables you to move the power chair, as well as monitor battery charge, electronic controller functions, and the condition of your electrical system. The VSI is an integral electronic controller. All of the electronics necessary to operate the power chair are contained in one module. See figure 30. Typically, the VSI is mounted to one of the armrests and is connected to the motors, batteries, and the onboard battery charger at the power base. The VSI may be used to control some optional systems such as power elevating seats and lights.

The controller supplied with your power chair has been pre-programmed to meet your needs. The program is set using either a personal computer with software provided by the controller manufacturer or with a hand-held programmer, also provided by the controller manufacturer.



WARNING! The controller program can affect speed, acceleration, deceleration, and braking. If it is programmed incorrectly or outside of the safe limits as determined by your healthcare professional, it can create a dangerous situation. Only the power chair manufacturer, an authorized representative of the manufacturer, or a trained service technician should program the controller.

The VSI consists of:

1. joystick
2. keypad
3. off-board charger/programming socket
4. actuator connector (*optional*)
5. controller connector
6. charger inhibit connector

Joystick

The joystick controls the direction and speed of your power chair. When you move the joystick from the neutral (center) position, the electromagnetic brakes release and allow your power chair to move. The farther you push the joystick from its neutral position, the faster your power chair moves. When you release the joystick and allow it to return to the neutral position, you engage the electromagnetic brakes. This causes your power chair to decelerate and come to a complete stop.



WARNING! If your power chair begins to move in an unexpected manner, immediately release the joystick. Unless the joystick is damaged, this action should stop your power chair.

Keypad

The keypad is located in front of the joystick. It contains keys necessary to operate your power chair. See figure 31.

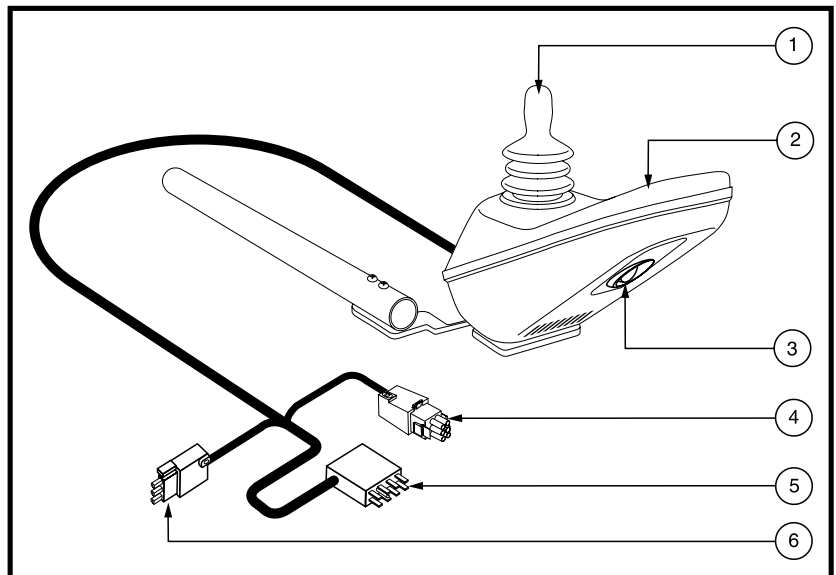

Figure 30. VSI Controller

VII. OPERATION

On/Off Key

The on/off key turns the VSI on and off.



WARNING! Unless faced with an emergency situation, do not use the on/off key to stop the power chair. This will cause the power chair to stop abruptly.

WARNING! Always turn the power off when you are stationary to prevent unexpected movement.

Battery Condition Meter

The battery condition meter is a 10-segment illuminated display located in front of the joystick. It consists of red, yellow, and green lights. When the lights are on, it indicates that there is power to the VSI. The lights also indicate battery status, VSI operational status, and electrical system status.

- **Red, yellow, and green lights lit:** Batteries charged; VSI operational, and electrical system OK.
- **Red and yellow lights lit:** Charge batteries if possible; VSI operational, and electrical system OK.
- **Red lights only lit or slow flash:** Charge batteries as soon as possible; VSI operational, and electrical system OK.

NOTE: When the batteries approach a discharged state, the first red light will begin to slowly flash, reminding you the batteries need to be charged immediately!

- **Rapid flash of lights:** Indicates a fault in the VSI or the electrical system. Refer to “VSI Error Codes.”
- **Ripple side to side of lights:** The joystick was not in the neutral position when the controller was turned on. If you get “ripple side to side of lights,” turn off the controller, allow the joystick to return to the neutral position, then turn on the controller.

NOTE: If you still get “ripple side to side of lights,” contact your authorized Pride Provider.

Speed/Profile Keys

The speed/profile keys control either the speed setting or the drive profile. Press the speed/profile increase key to increase the speed setting or change the drive profile to a higher number. Press the speed/profile decrease key to decrease the speed setting or change the drive profile to a lower number. The speed setting or drive profile is displayed on the maximum speed/profile indicator. If your power chair was programmed with a drive profile, contact your authorized Pride Provider for more information.

NOTE: We recommend that the first few times you operate your power chair, you use the lowest speed setting until you become familiar with your new power chair.

Actuator Keys and Actuator Lights (For Optional Equipment)

Actuator keys and actuator lights are used for optional equipment such as power elevating seats or power elevating leg rests. For specific operation of the actuator keys and actuator lights, contact your authorized Pride Provider.

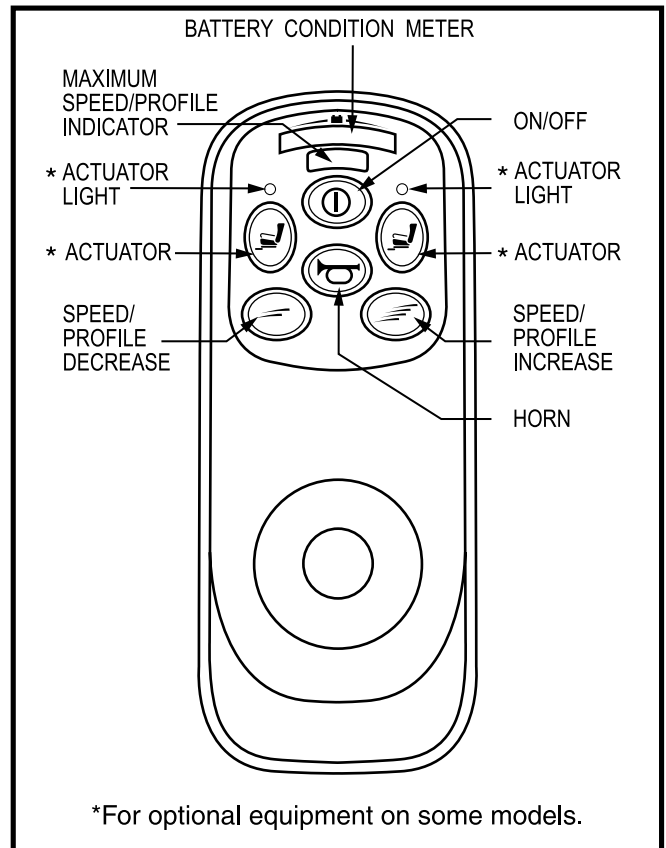

Figure 31. VSI Controller Keypad

VII. OPERATION

Horn Key

The horn key activates the horn.

Locking/Unlocking the VSI

The VSI has a feature that enables you to lock your power chair to prevent unauthorized use.

To lock the VSI:

1. With the VSI switched on, press and hold the on/off key. After 1 second, the VSI should beep.
2. Release the on/off key.
3. Push the joystick to the full forward position until the VSI beeps.
4. Pull the joystick to the full rearward position until the VSI beeps.
5. Release the joystick. There should be a long beep.
6. The VSI is now locked.

To unlock the VSI:

1. Press the on/off key to power on the VSI. The maximum speed/profile indicator should ripple side to side.
2. Push the joystick to the full forward position until the VSI beeps.
3. Pull the joystick to the full rearward position until the VSI beeps.
4. Release the joystick. There should be a long beep.
5. The VSI is now unlocked.

NOTE: *If the above procedure fails to either lock or unlock the VSI, contact your authorized Pride Provider.*

Off-board Charger/Programming Socket

The off-board charger/programming socket is located on the front of the VSI. If you use an off-board charger, the charger current should not exceed 8 amps. Contact your authorized Pride Provider for more information.



WARNING! Only chargers with Neutrik NC3MX plugs should be connected to the off-board charger/programming socket. See your authorized Pride Provider for more information.

Actuator Connector

The actuator connector connects the VSI to optional powered systems such as an elevating seat or lighting system.

Controller Connector

The controller connector connects the VSI to the power chair's batteries, motors, and motor brakes.

Charger Inhibit Connector

The charger inhibit connector connects the VSI to the onboard battery charger. This connection provides an inhibit that disables the VSI when the battery charger is on. The charger inhibit connector is coded with colored dots. The dots are positioned so that you align the flat side of the male connector with the flat side of the female connector before making the connection.



WARNING! Failure to properly align the connectors can result in damage to the controller, the charger, and the connectors.

VII. OPERATION

Thermal Rollback

The VSI controller is equipped with a thermal rollback circuit. This circuit monitors the temperature of the controller, which roughly translates to motor temperature. In the event that the VSI controller becomes excessively hot (above 140° F), motor current (amperage) is reduced. For every degree above 140° F, the motor current limit is reduced by .55 amps until the VSI controller reaches 158° F, at which time the current output is reduced to zero. This reduces your power chair's "power," which could also reduce your power chair's speed, and allows the electrical components and motors to cool down. When the temperature returns to a safe level, your power chair resumes its normal operation.

VSI Error Codes

The VSI controller is designed with the user's safety as the prime consideration. It incorporates many sophisticated self-test features which search for potential problems at a rate of 100 times per second. If the VSI detects a problem either in its own circuits or in the power chair's electrical system, it may decide to stop the power chair, depending on the severity of the problem. The VSI is designed to maximize the user's safety under all normal conditions. The table below identifies the individual error codes. Error codes are displayed as a rapid flashing of the battery condition meter lights. If you get one of these error codes, contact your authorized Pride Provider.

FLASHING LIGHTS	DIAGNOSIS AND SOLUTION
1	The batteries need charging or there is a bad connection to the batteries. Check the connections to the batteries. If the connections are good, try charging the batteries.
2	The left motor has a bad connection. Check the left motor connection.
3	The left motor has a short circuit to a battery connection. Contact your authorized Pride Provider.
4	The right motor has a bad connection. Check the right motor connection.
5	The right motor has a short circuit to a battery connection. Contact your authorized Pride Provider.
6	The power chair is being inhibited by the battery charger. Unplug the battery charger.
7	A joystick fault is indicated. Make sure that the joystick is in the neutral (center) position before turning on the controller.
8	A controller system fault is indicated. Make sure that all connections are secure.
9	The parking brakes have a bad connection. Check the parking brake and motor connections. Make sure the controller connections are secure.
10	An excessive voltage has been applied to the controller. This is usually caused by a poor battery connection. Check the battery connections.

VIII. BATTERIES AND CHARGING

BATTERIES AND CHARGING

Your power chair uses two long-lasting, 12-volt, deep-cycle batteries. These batteries are sealed and maintenance free. Since they are sealed, there is no need to check the electrolyte (fluid) level. Deep-cycle batteries are designed to handle a longer and deeper discharge. Though they are similar in appearance to automotive batteries, they are not interchangeable. Automotive batteries are not designed to handle a long, deep discharge, and also are unsafe for use in power chairs.

WARNING! Battery posts, terminals and related accessories contain lead and lead compounds. Wear goggles and gloves when handling batteries and wash hands after handling.



WARNING! Contact your authorized Pride Dealer if you have any questions regarding the batteries in your power chair.

WARNING! Always use two batteries of the exact same type, chemistry, and amp-hour (Ah) capacity. Refer to specifications table in this manual and in the manual supplied with the battery charger for recommended type and capacities.

Charging the Batteries

The battery charger is essential in providing long life for your power chair batteries. It is designed to optimize your power chair's performance by charging the batteries safely, quickly, and easily. The battery charging system consists of the battery charger, the charger circuit fuse, and the ammeter (onboard chargers only). The ammeter indicates the rate of charge necessary to fully recharge the batteries. It is also a good indication of whether or not the charger is working. The ammeter and the charger are only functional when the charger power cord is plugged into an electrical outlet.



PROHIBITED! Removal of grounding prong can create electrical hazard. If necessary, properly install an approved 3-pronged adapter to an electrical outlet having 2-pronged plug access.



PROHIBITED! Never use an extension cord to plug in your battery charger. Plug the charger directly into a properly wired standard electrical outlet.

WARNING! You must recharge your power chair's batteries with the supplied onboard battery charger. Do not use an automotive-type battery charger.

WARNING! Read the battery charging instructions in this manual and in the manual supplied with the battery charger before charging the batteries.

WARNING! Do not expose the battery charger to rain or other sources of moisture unless it has been tested for outdoor use. Refer to the manual supplied with the battery charger for more information.



WARNING! Explosive gases may be generated while charging the batteries. Keep the power chair and battery charger away from sources of ignition such as flames or sparks and provide adequate ventilation when charging the batteries.

WARNING! Inspect the battery charger, wiring, and connectors for damage before each use. Contact your authorized Pride Provider if damage is found.

WARNING! Do not attempt to open the battery charger case. If the battery charger does not appear to be working correctly, contact your authorized Pride Provider.

WARNING! If the battery charger is equipped with cooling slots, then do not attempt to insert objects through these slots.

WARNING! Do not allow unsupervised children to play near the power chair while the batteries are charging. Pride recommends that you do not charge the batteries while the power chair is occupied.

VIII. BATTERIES AND CHARGING



WARNING! If your battery charger has not been tested and approved for outdoor use, then do not expose it to adverse or extreme weather conditions. If the battery charger is exposed to adverse or extreme weather conditions, then it must be allowed to adjust to the difference in environmental conditions before use indoors. Refer to the manual supplied with the battery charger for more information.

To charge the batteries using the onboard charger:

1. Position the rear of your power chair close to a standard electrical outlet.
2. Be certain the controller power is turned off and the freewheel levers are in the engaged position. See III. “Your Power Chair.”
3. Plug the charger power cord into the charger power cord receptacle on the power base, then into the electrical outlet.

NOTE: *The power chair incorporates an inhibit function that disables the power chair when the charger is plugged into an electrical outlet.*

4. We recommend you charge the batteries for 8 to 14 hours. As the batteries charge, the ammeter needle slowly drops to 0.

NOTE: *The ammeter indicates how much charge is needed to fully charge the batteries. As the batteries charge, the ammeter needle slowly drops to 0. When the batteries are fully charged, the needle vibrates on or about the 0 mark on the ammeter.*

5. When your power chair’s batteries are fully charged, disconnect the charger power cord, wind up the cord, and store it in a safe place.

Battery Break-in

To break in new batteries for maximum efficiency:

1. Fully recharge any new battery prior to its initial use. This brings the battery up to about 90% of its peak performance level.
2. Operate your power chair throughout the house and yard. Move slowly at first, and do not travel too far until you become accustomed to the controls and break in the batteries.
3. Give the batteries another full charge of 8 to 14 hours and operate your power chair again. The batteries will now perform at over 90% of their potential.
4. After four or five charging cycles, the batteries will top off at 100% charge and last for an extended period.

Frequently Asked Questions (FAQs)

How does the charger work?

The battery charger takes the standard electrical outlet voltage of 120 VAC (alternating current) and converts it to 24 VDC (direct current). The power chair batteries use direct current to run your power chair. When the battery voltage is low, the charger works harder to charge the battery. As the battery voltage approaches full charge, the charger doesn’t work as hard to complete the charging cycle. When the battery is fully charged, the amperage from the charger is nearly at zero. This is how the charger maintains a charge but does not overcharge the battery.

Can I use a different battery charger?

You should use the charger supplied with the power chair. It is the safest, most efficient tool to charge the batteries. We do not recommend using other types of chargers (e.g., an automotive battery charger).

VIII. BATTERIES AND CHARGING

NOTE: *Your power chair's charger will not operate after the batteries have been discharged to nearly zero voltage. If this happens, call your authorized Pride Provider for assistance.*

How often must I charge the batteries?

Many factors come into play when deciding how often to charge the batteries. You may use your power chair all day on a daily basis or you may not use it for weeks at a time.

■ **Daily Use**

If you use your power chair on a daily basis, charge the batteries as soon as you are finished using your power chair. Your power chair will be ready each morning to give you a full day's service. It is recommended that you charge the batteries 8 to 14 hours after daily use.

■ **Infrequent Use**

If you use your power chair infrequently (once a week or less), you should charge the batteries at least once per week for 12 to 14 hours.

NOTE: *Keep your batteries fully charged and avoid deeply discharging your batteries. Do not charge the batteries for more than 24 hours at a charging cycle.*

How can I get maximum range or distance per charge?

Rarely do you have an ideal driving situation such as smooth, flat, hard terrain with no wind, hills, or curves. More often you are presented with hills, sidewalk cracks, uneven and loosely packed surfaces, curves, and wind. All of these factors will affect the distance or running time per battery charge. Below are a few suggestions for obtaining the maximum range per charge:

- Always charge the batteries fully prior to your trip.
- Plan your trip in advance to avoid inclines if possible.
- Limit baggage weight to essential items.
- Try to maintain an even speed and avoid stop-and-go driving.

What type of batteries should I use?

We recommend deep-cycle batteries that are sealed and maintenance free. Both AGM and Gel-Cell are deep-cycle batteries that are similar in performance.



WARNING! Corrosive chemicals contained in batteries. Use only AGM or Gel-Cell batteries to reduce the risk of leakage or explosive conditions.

Why do my new batteries seem weak?

Deep-cycle batteries employ a much different chemical technology than that used in car batteries, nickel-cadmium (nicads), or in other common battery types. Deep-cycle batteries are specifically designed to provide power, drain down their charge, and then accept a relatively quick recharge. AGM and Gel-Cell batteries should be charged as often as possible. They do not have a "memory" like nickel-cadmium batteries.

We work closely with our battery manufacturer to provide a battery that best suits your power chair's specific demands. Fresh batteries arrive regularly at Pride and are promptly shipped with a full charge. During shipping, the batteries encounter temperature extremes that may influence initial performance. Heat robs the charge from the battery, and cold slows the power available and extends the time needed to recharge the battery (just as with a car battery).

VIII. BATTERIES AND CHARGING

It might take a few days for the temperature of the battery to stabilize and adjust to its new ambient temperature. More importantly, it will take a few “charging cycles” (a partial drain— then a full recharge) to establish the critical chemical balance that is essential to the battery’s peak performance and long life. It will be well worth it to take the time to break in your battery properly.

How can I ensure maximum battery life?

A fully charged deep-cycle battery will provide reliable performance and extended battery life. Keep your power chair’s batteries fully charged whenever possible. Batteries that are regularly and deeply discharged, infrequently charged, or stored without a full charge may be permanently damaged, causing unreliable power chair operation and limited battery life.

NOTE: The useful life of a battery is quite often a reflection of the care it receives.

How should I store my power chair and its batteries?

If you do not use your power chair regularly, we recommend maintaining battery vitality by charging the batteries at least once per week.

If you do not plan on using your power chair for an extended period, fully charge the batteries prior to storage. Disconnect the battery harnesses and store the power chair in a warm, dry environment. Avoid temperature extremes, such as freezing and excessively hot conditions, and never attempt to charge a frozen battery. A cold or frozen battery should be warmed for several days prior to recharging.

What about public transportation?

AGM and Gel-Cell batteries are designed for application in power chairs and other mobility vehicles. These batteries are Federal Aviation Administration (FAA) approved, allowing safe transportation on aircraft, buses, and trains, as there is no danger of spillage or leakage. We suggest you contact the carrier’s ticket counter in advance to determine that carrier’s specific requirements.

What about shipping?

If you wish to use a freight company to ship your power chair to your final destination, repack your power chair in the original shipping container and ship the batteries in separate boxes.

IX. CARE AND MAINTENANCE

CARE AND MAINTENANCE

Your Jazzy 100 is a sophisticated power chair. Like any motorized vehicle, it requires routine maintenance checks. You can perform some of these checks, but others require assistance from your authorized Pride Provider. Preventive maintenance is very important. If you follow the maintenance checks in this section as scheduled, you can help ensure that your power chair gives you years of trouble-free operation. If you have any doubt as to your power chair's care or operation, contact your authorized Pride Provider.



WARNING! Do not service the power chair when the seat is occupied.

Your power chair, like most electrical equipment, is susceptible to damage from the elements. Avoid damp areas of any kind.



WARNING! Direct or prolonged exposure to water or dampness could cause the power chair to malfunction electronically and mechanically. Water can cause electrical components to corrode and the chair's frame to rust. Power chairs should be examined periodically for signs of corrosion caused by water exposure, bodily fluids exposure, or incontinence. Damaged components should be replaced or treated immediately.

Should your power chair come in contact with water:

1. Dry your power chair as thoroughly as possible with a towel.
2. Allow your power chair to sit in a warm, dry place for 12 hours to allow unseen water to evaporate.
3. Check the joystick operation and the brakes before using your power chair again.
4. If any inconsistencies are found, take your power chair to your authorized Pride Provider. Power chairs that are frequently exposed to sources of water, such as incontinence, should be inspected often for corrosion and electronic components may need to be replaced frequently.

Temperature

- Some of the parts of your power chair are susceptible to extreme changes in temperature. Always keep your power chair between the temperatures of 18° F and 122° F.
- In extremely cold temperatures the batteries may freeze. The specific temperature at which they freeze depends on a number of factors, such as battery charge, usage, and composition of the batteries (e.g., AGM or Gel-Cell).
- Temperatures above 122° F may cause your power chair to operate at a reduced speed. This reduced speed is a safety feature built into the controller that helps prevent damage to the motor and other electrical components.

General Guidelines

- Avoid knocking or bumping the controller, especially the joystick.
- Avoid prolonged exposure of your power chair to extreme conditions, such as heat, cold, or moisture.
- Keep the controller clean.
- Check all connectors to ensure that they are all tight and secured properly.
- Make sure the pneumatic tires are inflated to **35 psi (2.4 bar)** if equipped with pneumatic tires..



WARNING! Make sure your tires are inflated to 35 psi (2.4 bar). Do not underinflate or overinflate your tires. Low pressure may result in loss of control, and overinflated tires may burst. Overinflating tires can cause them to explode.

WARNING! Do not use a high pressure hose to inflate your tires.

- Use a rubber conditioner on the tire sidewalls to help preserve them.



WARNING! Never use a rubber conditioner on the tread area of the tires; doing so may make the tires slippery and cause your power chair to skid.

IX. CARE AND MAINTENANCE

- The body shroud has been sprayed with a clear sealant coating. You can apply a light coat of car wax to help it retain its high-gloss appearance.
- Check all electrical connections. Make sure they are tight and are not corroded. Batteries must sit flat within the battery boxes and battery well frame with the battery terminals facing inward toward each other. Refer to the battery wiring label for the correct wiring layout.



WARNING! Even though the power chair has passed the necessary testing requirements for ingress of liquids, you should keep electrical connections away from sources of dampness, including direct exposure to water or bodily fluids and incontinence. Check electrical components frequently for signs of corrosion and replace as necessary.

- All wheel bearings are prelubricated and sealed. They require no subsequent lubrication.

Daily Checks

- With the controller turned off, check the joystick. Make sure it is not bent or damaged and that it returns to the neutral position when you release it. Check the rubber boot around the base of the joystick for damage. Visually inspect the boot. Do not handle or try to repair it. See your authorized Pride Provider if there is a problem.
- Visually inspect the controller communications cable. Make sure that it is not frayed, cut, or has any wires exposed. See your authorized Pride Provider if there is a problem.
- Check for flat spots on solid tires. Flat spots could adversely affect stability.

Weekly Checks

- Disconnect and inspect the controller cable and the charger harness from the power base. Look for corrosion. Contact your authorized Pride Provider if necessary.
- Ensure that all parts of the controller system are securely fastened to your power chair. Do not overtighten any screws.
- Check for proper tire inflation. There should be **35 psi (2.4 bar)** in each tire. If a tire does not hold air, see your authorized Pride Provider for replacement of the tube.
- Check the brakes. This test should be carried out on a level surface with at least 3 feet of clearance around your power chair.

To check the brakes:

1. Turn on the controller and turn down the speed level of your power chair.
2. After one second, check the battery condition meter. Make sure that it remains on.
3. Slowly push the joystick forward until you hear the electric brakes click. Immediately release the joystick. You must be able to hear each electrical brake operating within a few seconds of joystick movement. Repeat this test three times, pushing the joystick backward, then left, and then right.

Monthly Checks

- Check that the anti-tip wheels do not rub the ground when you operate the power chair. Adjust them as necessary.
- Check for extreme wear on the anti-tip wheels. Replace them as necessary.
- Check for drive tire wear. See your authorized Pride Provider for repair.
- Check the caster wheels for wear. Replace them as necessary.
- Check the caster forks for damage or fluttering which indicates that they may need to be adjusted or have the bearings replaced. See your authorized Pride Provider for repair.
- Keep your power chair clean and free of foreign material, such as mud, dirt, hair, food, drink, etc.

Yearly Checks

Take your power chair to your authorized Pride Provider for yearly maintenance, especially if you use your power chair on a daily basis. This helps ensure that your power chair is functioning properly and helps prevent future complications.

IX. CARE AND MAINTENANCE

Storage

Your power chair should be stored in a dry place, free from temperature extremes. When storing, disconnect the batteries from the power chair. See VI. “Batteries and Charging.”



WARNING! If you fail to store the unit properly, the frame can rust and the electronics can be damaged.

Batteries that are regularly and deeply discharged, infrequently charged, stored in extreme temperatures, or stored without a full charge may be permanently damaged, causing unreliable performance and limited service life. It is recommended that you charge the batteries periodically throughout periods of prolonged storage to ensure proper performance.

You may wish to place several boards under the frame of your power chair to raise it off of the ground during periods of prolonged storage. This takes the weight off the tires and reduces the possibility of flat spots developing on the areas of the tires contacting the ground.

Disposal of Your Power Chair

Your power chair must be disposed of according to applicable local and national statutory regulations. Contact your local waste disposal agency or authorized Pride Provider for information on proper disposal of power chair packaging, metal frame components, plastic components, electronics, and batteries.

Cleaning and Disinfection

- Use a damp cloth and mild, non-abrasive cleanser to clean the plastic and metal parts of your power chair. Avoid using products that may scratch the surface of your power chair.
- If necessary, clean your product with an approved disinfectant. Make sure the disinfectant is safe for use on your product before application.

WARNING! Follow all safety instructions for the proper use of the disinfectant and/or cleaning agent before applying it to your product. Failure to comply may result in skin irritation or premature deterioration of upholstery and/or power chair finishes.



WARNING! Never hose off your power chair or place it in direct contact with water. Your power chair has a painted, ABS plastic body shroud that allows it to be easily wiped clean with a damp cloth.

WARNING! Never use any chemicals to clean a vinyl seat, as they may cause the seat to become slippery or dry out and crack. Use soapy water and dry the seat thoroughly.

Wheel Replacement

If you have pneumatic tires and you have a flat tire, replace the tube. If your chair is equipped with a solid tire insert, then you must replace the whole wheel assembly. Replacement tires, tubes, and wheel assemblies are readily available through your authorized Pride Provider.

WARNING! The wheels on your power chair should only be serviced or replaced by an authorized Pride Provider or a qualified technician.



WARNING! Be sure that the controller's power is turned off and the power chair is not in freewheel mode before performing this procedure.

WARNING! When changing a tire, remove only the center lug nut and washer, then remove the wheel. If any further disassembly is required, deflate the tire completely or it may explode.

IX. CARE AND MAINTENANCE

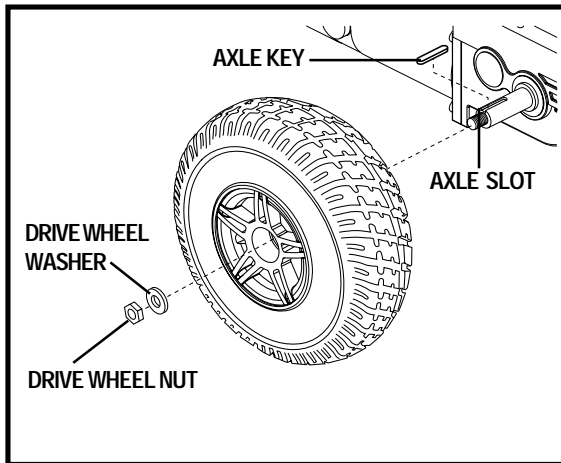

Figure 32. Drive Wheel

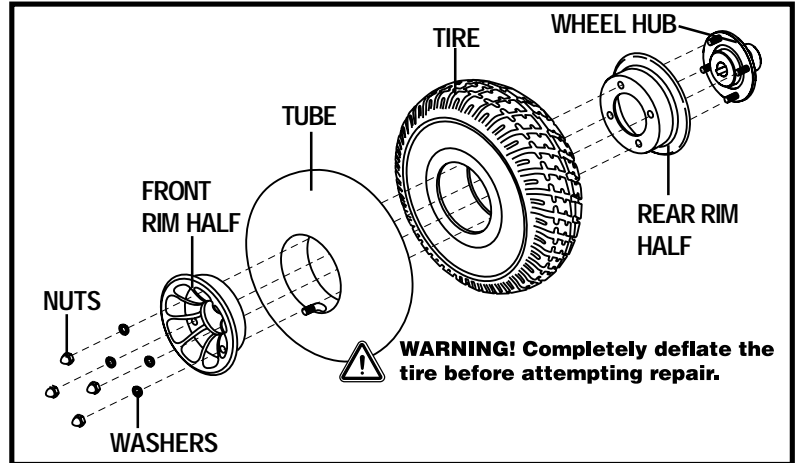

Figure 33. Drive Wheel Disassembled

Follow these easy steps for a quick and safe repair for both pneumatic and solid tires:

1. Turn off the power to the controller.
2. Set the power chair up on blocks.
3. If you are changing a pneumatic tire, completely deflate it before removing the wheel.
4. Remove the drive wheel nut and washer from the axle. See figure 32.
5. Pull the wheel off the axle.
6. Remove the nuts and washers from the wheel hub and separate the front and rear rim. See figure 33.
7. Remove the old tube from the pneumatic tire and replace it with a new tube or replace the entire assembly if it is a solid tire.
8. Reassemble the rims and reinstall the nuts and washers to the wheel hub.
9. Slide the wheel back onto the axle. Make sure the key is in the axle slot.
10. Reinstall the drive wheel nut and washer onto the axle and tighten.
11. Inflate the pneumatic tire to **35 psi (2.4 bar)**.
12. Remove the power chair from the blocks.

Battery Replacement

A battery wiring diagram is printed on a decal located on the battery well frame. Refer to the specifications table for correct battery specifications.

WARNING! The batteries on your power chair should only be serviced or replaced by an authorized Pride Provider or a qualified technician.

WARNING! Do not replace the battery when the seat is occupied.

WARNING! Battery posts, terminals, and related accessories contain lead and lead compounds. Wear goggles and gloves when handling batteries and wash hands after handling.



WARNING! Power chair batteries are heavy. See specifications table. If you are unable to lift that much weight, be sure to get help.

WARNING! Do not mix or match new and old batteries. If you encounter a situation where one battery needs to be replaced, then replace both batteries. Refer to specification table in this manual and the manual supplied with the battery charger for recommended type and capacities.

IX . CARE AND MAINTENANCE

To replace the batteries:

1. Turn off the power to the controller.
2. Make sure that the power chair is in drive mode. See III. “Your Power Chair.”
3. Unplug the controller connector from the power base.
4. Remove the seat.
5. Unplug the battery quick-connectors from the power base.
6. Remove the battery boxes from the battery well, and open the lids.
7. Remove the old batteries.
8. Disconnect the wiring harnesses from the batteries.
9. Connect the wiring harness to the new batteries.



WARNING! Make sure you tighten the fasteners so that the connections are secure.

10. Place the new batteries into the battery boxes and replace the lids.
11. Place the battery boxes into the battery well on the power base and refasten the straps.
12. Plug in the quick-connectors.
13. Reinstall the seat.
14. Plug the controller connector into the power base.
15. Charge the batteries.

When to See Your Authorized Pride Provider for Service

The following symptoms could indicate a serious problem with your power chair. If necessary, contact your authorized Pride Provider. When calling, have the model number, serial number, nature of the problem, and the error code if available.

- Motor noise
- Frayed harnesses
- Cracked or broken connectors
- Uneven wear on any of the tires
- Jerky motion
- Pulling to one side
- Bent or broken wheel assemblies
- Does not power up
- Powers up, but does not move

Corrective Maintenance

If the battery condition meter does not light up when you turn on the power:

- Check the harness connections. Make sure they are tight.
- Check the circuit breaker. Reset it if necessary.
- Check the battery connections.

If the above conditions prove normal, you can load test the batteries with a battery load tester. These testers are available at automotive parts stores. Disconnect both batteries before load testing and follow the directions that come with the load tester. If either one of the batteries fails the load test, replace both of them. If your power chair still does not power up, contact your authorized Pride Provider.

X . W A R R A N T Y

FIVE-YEAR LIMITED WARRANTY

For five (5) years from the date of purchase, Pride will repair or replace at our option to the original purchaser, free of charge, any of the following parts found upon examination by an authorized representative of Pride to be defective in material and/or workmanship:

Structural frame components, including:

- Main Frame
- Seat Post

ONE-YEAR LIMITED WARRANTY

For one (1) year from the date of purchase, Pride will repair or replace at our option to the original purchaser, free of charge, any of the following parts found upon examination by an authorized representative of Pride to be defective in material and/or workmanship:

Electronic components, including:

- Charger Assembly
- Controller
- Joystick

Main frame assemblies, including:

- Anti-tip forks
- Caster forks
- Caster beam
- Metal seat framing
- Accessories

Other components, including:

- Brakes (electronic function ONLY)
- Motor/gearbox assembly
- Foot riggings
- Bearings and bushings
- Plastic components, except body
- Electrical Harness
- Foot rigging mounting brackets

SIX-MONTH LIMITED WARRANTY

The battery is covered by a separate six-month warranty, provided by the battery manufacturer. The batteries are not warranted by Pride.

RECONDITIONED UNITS WARRANTY

All reconditioned units are covered by a six-month warranty from Pride effective from the date of purchase.

WARRANTY EXCLUSIONS

This warranty does not extend to those items which may require replacement due to normal wear and tear.

- ABS Plastic shrouds
- Motor brushes
- Upholstery and seating
- Brake Pads
- Tires and tubes
- Fuses

- Circumstances beyond the control of Pride
- Labor, service calls, shipping, and other charges incurred for repair of the product, unless specifically authorized, IN ADVANCE, by Pride Mobility Products Corporation
- Repairs and/or modifications made to any part without specific consent from Pride

Exclusions also include components with damage caused by:

- Contamination
- Abuse, misuse, accident, or negligence
- Battery fluid spillage or leakage
- Commercial use, or use other than normal
- Improper operation, maintenance, or storage

X . W A R R A N T Y

NOTE: Gradual deterioration in performance because the battery has been left in a discharged state, left in cold conditions for an extended period of time, or worn out through heavy use is not covered.

SERVICE CHECKS AND WARRANTY SERVICE

Warranty service must be performed by an authorized Pride Provider. Do not return faulty parts to Pride without prior written authorization. All transportation costs and shipping damage incurred while submitting parts for repair or replacement are the responsibility of the purchaser.

Failure to follow the instructions, warnings, and notes in the owner's manual and those located on your Pride product can result in personal injury or product damage and will void Pride's product warranty.

There is no other express warranty.

IMPLIED WARRANTIES

Implied warranties, including those of merchantability and fitness for a particular purpose, are limited to one (1) year from the date of purchase and to the extent permitted by law. Any and all implied warranties are excluded. This is the exclusive remedy. Liabilities for consequential damages under any and all warranties are excluded.

Some states do not allow limitations on how long an implied warranty lasts or do not allow the exclusion of limitation incidental or consequential damages. The above limitation or exclusion may not apply to you.

This warranty gives you specific rights, and you may also have other rights which vary from state to state.

Please fill out and return the product registration card to Pride. This will aid Pride in providing the best possible technical and customer service.

Quality Control - Jazzy 100

Inclusion of all Parts

Joystick Serial Number

Controller Serial Number

Left Motor Serial Number

Right Motor Serial Number

Fit and Finish

Performance



Pride keeps a more detailed report on file at the factory.

Date Inspected

Inspector

I NFMANU3537

Product Serial #