

ITEM # _____

MODEL # _____

PROJECT NAME # _____

SIS # _____

AIA # _____

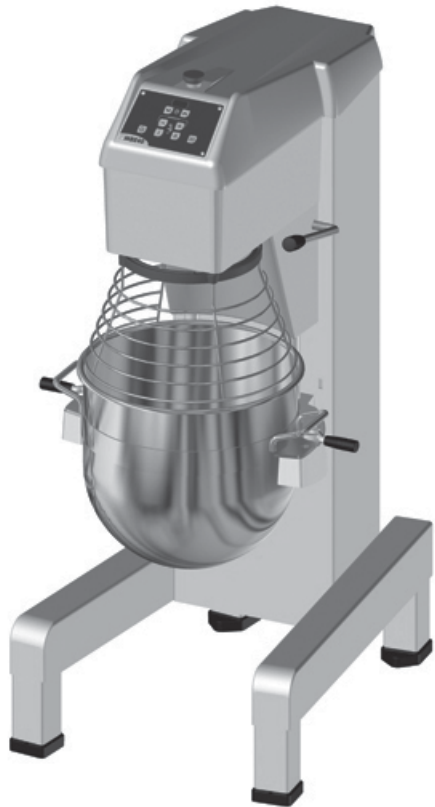

Planetary Mixer XEM-40 42 Qt. Floor Model

603392 (XEM40S) 42 Qt. Floor Model Planetary Mixer
200-240 V/1p/60Hz

Short Form Specification

Item No. _____

Unit to be Electrolux-Dito 42 Qt. Planetary Mixer with features that include: stainless steel bowl. One-piece alloy head containing the self-lubricating planetary gears and the transmission. Powerful motor with mechanical speed variation with 10 speeds. A single lever is used to raise and lower the bowl. A safety device will automatically stop the machine when the bowl is lowered. Supplied with 3 tools: Beater, Dough Hook and Whisk.

Main features

- Power: 3.0 HP—single phase.
- Variable speed: 30-160 rpm.
- 2.2 kW.
- Red OFF, green ON buttons, and timer.
- Compact design.
- 10 speeds that permit exceptional results.
- The "V" belt speed variator protects the mechanism and the motor against incorrect use.
- Stainless steel bowl - 42 qt. capacities.
- Raising and lowering of the bowl controlled by lever with an automatic locking of the bowl when in the raised position.
- Safety device will automatically stop the machine when the bowl is lowered.
- Powerful motor with high start-up torque.
- Planetary gearing with self-lubricating gears eliminating any risk of leaks.
- Sturdy construction with mechanically welded strong metal frame.
- Delivered with:
 - Beater, Dough Hook, Wire Whisk and Mixing Bowl for 42 qt.
- Dimensions: (LxWxH): 33.5" x 25.5" x 53.5".
- Approx. shipping weight—463 lbs.
- ETL electrical and sanitation listed/CETL (Canada).
- NEMA # : 6-20P
- 2 year parts warranty, 1 year labor.

Accessories

- Beater for 42 qt. Mixer.
- Dough Hook for 42 qt. Mixer.
- Wire Whisk for 42 qt. Mixer.
- Mixing Bowl for 42 qt. Mixer.

Optional Accessories

- Beater for 42 qt. Mixer (PNC 653093)
- Dough Hook for 42 qt. Mixer (PNC 653092)
- Wire Whisk for 42 qt. Mixer (PNC 653127)
- Mixing Bowl for 42 qt. Mixer (PNC 653247)
- Gas Heater for 42 qt. (PNC 653430)
- Trolley for 42 qt. Mixing bowl (PNC 653033)
- Stainless Steel tray/shelf for 42 qt. Mixer (PNC 653436)



NEMA #: 6-20P

Approval: _____

Front View

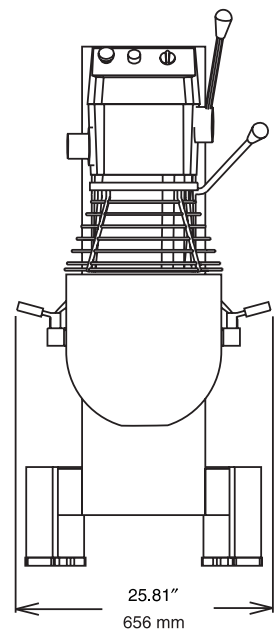

Electric

Supply voltage:
603392 (XEM40S) 200-240 V/1p/60Hz - 16 A

Key Information

Working capacity – lbs. of flour

Shortcrust pastry:	22
Cold water paste:	20
Sweet pastry:	22
Croissant:	20
Brioche:	20
Meat:	44
Potato Puree:	44

Top View

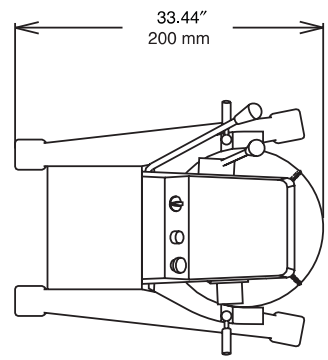

EC = Electrical connection

Side View

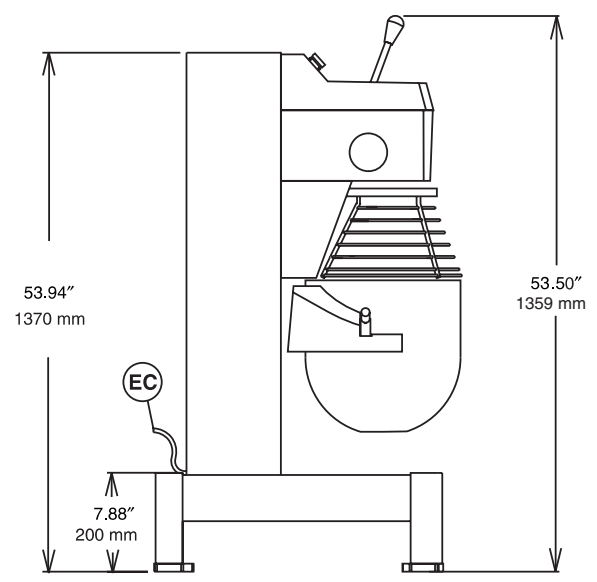

Planetary Mixer
XEM-40 42 Qt. Floor Model