

# DOMINO

## Two-zone Ceramic Hob Unit

User instructions

ZBX 623 SS

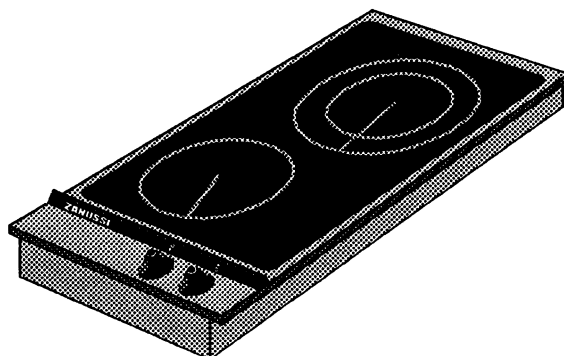

Model no. ZBX 623 SS  
Product no. 9496 00135  
Serial no.



# ZANUSSI

## CONTENTS

	<b>Page</b>
Technical Specification .....	3
Warnings .....	4-5
Maintenance And Cleaning .....	6-9
Installation .....	10-11
Electrical Connections .....	12
Operating Instructions .....	12-14
If The Unit Does Not Work .....	14
Peace Of Mind For 24 Months .....	15

### **Information!**

Welcome to your new ceramic hob. Its stylish and practical design will enhance your kitchen and make "cooking electric" a pleasure.

Even if you have used a ceramic hob before, it is important that you read these instructions thoroughly before starting to cook, paying particular attention to the installation and safety instructions.

### **Getting help**

If you have any problems with installing or operating your new cooker, please contact your retailer or local Zanussi Service Centre for advice.

Respectfully  
**ZANUSSI**

## TECHNICAL SPECIFICATION

<b>Model name</b>	:	ZBX 623 SS
<b>Product no</b>	:	949 600 135
<b>Plate dimensions</b>	:	1. 14 cm. Halogen 1200 Watt 2. 12/18 cm. High-light 750/1700 Watt
<b>Residual Heat Indicators</b>	:	At each zone
<b>Material</b>	:	Stainless Steel
<b>Signal Lamp:</b>	:	On/off
<b>Mains Voltage</b>	:	240V - 50 Hz
<b>Max Power Consumption</b>	:	2.9 kW
<b>Built-In Measurements</b>	:	Height : 45 mm. Width : 280 mm. Depth : 490 mm.
<b>Product Measurements</b>	:	Gross / Net Height : 180 / 75 mm. Width : 360 / 290 mm. Depth : 590 / 510 mm.
<b>Weight</b>	:	Gross : 7.3 Kg.
<b>Gross Volume</b>	:	0,0500 m <sup>3</sup> .
<b>Approval</b>	:	CE 96

**This two-burner ceramic hob unit is intended for household use only.**

This unit is  labelled to indicate conformity with the low voltage

directive (73/23/EEC) and the EMC directive (89/336/EEC).

# WARNINGS

**It is most important that this instruction book should be retained with the appliance for future reference. Should the appliance be sold or transferred to another owner, or should you move house and leave the appliance, always ensure that the book is supplied with the appliance in order that the new owner can get to know the functioning of the appliance and the relevant warnings.**

## Before Installation

- Ensure that all packaging, both inside and outside the hob has been removed before the hob is used.
- After installation, please dispose of the packaging with due regard to safety and the environment.
- The electrical installation work must be undertaken by a qualified electrician, or competent person.
- It is dangerous to alter or modify the specifications of the hob in any way.
- **Do not use the hob if it is damaged in any way. If a fault or crack becomes visible during cooking, disconnect the cooker immediately from the electricity supply and contact your local Zanussi Service Centre.**

## During Operation

- Do not use this hob with wet hands.
- This cooker is designed to be operated by adults. Young children must not be allowed to tamper with the hob or play with the controls. Accessible parts around the hob area may become hot when the cooker is in use. Children should be kept away until it has cooled.
- Take great care when heating fats and oils as they will ignite if they become too hot.
- This hob has been designed for cooking edible foodstuffs only, and must not be used for any other purposes.
- Never place plastic, or any other material which may melt, on the hob.
- Ensure cooking utensils are large enough to contain foods to prevent spillages and boil-overs.
- The handles of saucepans whose bases are smaller than the heated area of the hob will become very hot. Ensure your hand is protected before handling the pan.
- Only use pots and pans with a rigid, even base, suitable for ceramic hobs. Uneven contact surfaces result not only in poor heat conduction, but increase the risk of dangerous spills.

- Do not leave the hob switched ON for long periods when not covered by a saucepan as the controls may overheat.
- During deep-fat frying, sauteing, melting butter, etc., always remain vigilant and never leave the hob as there is a risk of fire. In the event of a fire, shut off the hob immediately and switch off any extractor fan if in use.
- Hobs become very hot, and retain their heat for a long period of time after use. Children should be kept well away from the cooker until it has cooled.
- Always place the saucepan handles in such a way that they do NOT protrude over the edge of the work surface where they would be a safety hazard.

## Before Use

- Before using the hob unit, it is advisable to clean the ceramic surface with the enclosed cleaning agent.
- Use a clean, damp cloth. Dry with a clean cloth.

## After Use

- Ensure that all control knobs are in the OFF position when not in use.
- For hygiene and safety reasons, this cooker should be kept clean at all times. A build-up of fats or other foodstuffs, e.g. fat or oil could result in a fire.
- Never leave empty pans, or pans with oil or fat on the hob in case it is inadvertently switched ON.

## General

- Under no circumstances should repairs be carried out by inexperienced persons as this may cause injury or serious malfunction of the appliance.
- This hob should be serviced by an authorised Zanussi Service engineer and only approved Zanussi spare parts should be used.
- Always switch OFF the hob at its power point and allow it to cool before any cleaning or service work is carried out.
- Only clean this hob in accordance with the instructions given in this book.
- If this hob becomes unsafe to use and is discarded, please render it useless by removing the cable altogether or cutting the cable as close the hob as possible.

# MAINTENANCE AND CLEANING

For best results, the ceramic surface should be cleaned after every use. Use a clean cloth, which has been dipped in warm, soapy water (use liquid AJAX or a washing up liquid).

Cleaning agents that contain bleach should NOT be used as they may dull the surface finishes. **Harsh abrasives should also be avoided.**

All spills must be cleaned up immediately, while the hob is still warm.

Spots caused by utensils with aluminium bases, by burned grease, or by chalk deposits, etc., can be removed by polishing with the cleaning agent supplied with the hob. In extreme cases, polishing may have to be repeated several times in order to remove the blemish entirely.

After cleaning any part of the hob, the ceramic surface should be polished using a suitable cleaning agent.

## Cleaning Borders and Edges

Take care to avoid the hob trims when cleaning the ceramic glass as they may be damaged by the cleaning agents.

**Take care not to switch on the hob unit by accident whilst cleaning the control panel.**

## WARNING!

Never use scouring powder, scouring sponges, or any other cleaning agent which can scratch the ceramic surface.

## Daily Cleaning of the Ceramic Surface

Use the recommended Hob Brite cleaner daily. If spillage is not allowed to burn on, it is much easier to clean off.

1. Apply a small amount of Hob Brite to the centre of each area to be cleaned.
2. Dampen a clean paper towel or a plastic pad made especially for non-stick saucepans and rub vigorously until all marks are removed. This may take a few minutes.
3. Wipe off any cleaner residue with another damp paper towel and polish dry with a soft cloth.

If Hob Brite is unavailable, one or more of the cleaning agents below may be used temporarily:

- a) Flash Cream Cleaner.
- b) Jif Cream Cleaner.
- c) Baking Soda.

## To Remove Stubborn Marks

1. Hob Brite can be used to clean off more stubborn stains or to remove discolourations.
2. Use a plastic pad made specially for non-stick saucepans with Hob Brite for removal of more stubborn soilage.

## To Remove Burnt On Spillage

1. Make sure the ceramic glass is cool.
2. Use a safety scraper at an angle of 30° to remove as much soilage as possible.
3. Use Hob Brite to finish off as directed above.

## **To Remove Discolourations or White/Silver Marks**

These marks sometimes give the impression of being in or underneath the hob glass.

They can almost always be removed provided they have not become excessively burnt on. Follow the instructions headed "To Remove Stubborn Marks".

If this is unsuccessful, make up a paste of one part water to three parts Cream of Tartar and leave on the discoloured areas overnight.

The marks should easily be removable the next day with vigorous rubbing. The paste should be thoroughly washed off afterwards.

### **IMPORTANT!**

Make it a habit to always wipe the base surface of pots and pans with a clean, dry cloth before placing them on the ceramic surface.

The decorative pattern on the ceramic surface can become scratched and marred with use, depending upon maintenance, but does not adversely affect performance.

Such blemishes are NOT covered by the warranty.

Spills and melts must be removed immediately, while the burner is still warm, using a safety scraper.

Especially damaging are melted plastics, aluminium, or any foodstuff containing sugar, including natural

sugar, as these can create permanent "pockmarks" and craters on the ceramic surface. After scraping, polish thoroughly with the cleaning agent supplied with the hob.

Utensils which have been in contact with the above mentioned materials must be cleaned thoroughly before being used again on the ceramic top hob unit.

Defects in the ceramic surface which can be related to the above are not covered by the warranty.

### **Avoid The Use Of:**

- Household detergents and bleaches.
- Impregnated plastic or nylon pads NOT described as suitable for non-stick purposes.
- Brillo pads, Ajax pads, steel wool pads.
- Chemical oven cleaners, e.g. aerosols and oven pads.
- Rust stain, bath and sink stain removers.

**Any of the above products may cause damage to the hob.**

NEVER mix different cleaning products. The chemicals in them may react with each other with dangerous results.

**spillage from sugar solutions must be removed from the hob before the syrup has set, otherwise damage to the hob surface will occur.**

Avoid placing aluminium foil or dishes on the hot surface as this could cause damage to the hob.

## Use Proper Cooking Utensils

Saucepans with aluminium bases can cause light spots on the ceramic surface. These can be removed with the cleaning agent supplied with the hob.

Saucepans must cover the entire circle of the hotplate.

The underside of the saucepan must form a flat, even surface.

Ensure that both contact surfaces - the saucepan's as well as the hob's, are absolutely dry.

Saucepans with enamelled bases cause excessive wear on the decorative pattern of the ceramic surface.

Saucepans with painted bases must NOT be used as the paint can be transferred to the ceramic surface where it will stick permanently, causing a "pocked" surface.

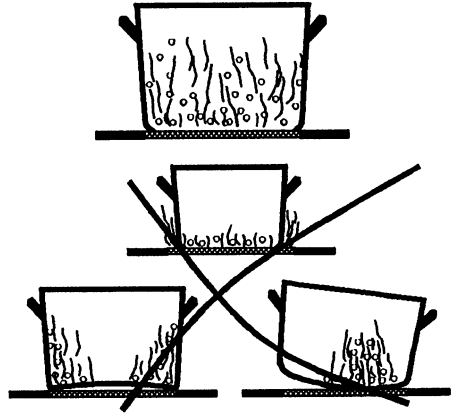

## Hints and Tips

Make sure the base of the saucepans and the cooking area are clean and dry before cooking begins.

Ensure saucepans are large enough to accommodate food and to avoid boil-overs.

If possible, wipe up spills and splatters as they occur, but take care to avoid steam burns.

Avoid using a dishcloth or sponge to clean the hob. They may leave a layer of soiled detergent on the hob's surface

which will burn and discolour the next time the hob is used.

Lift, rather than slide saucepans on and off the heated areas. This will reduce the risk of scratches and metal marks from saucepans with aluminium bases. Metal marks can be easily removed providing they are cleaned off straight away and not allowed to burn on.

Follow any guidelines provided by the saucepan manufacturer, particularly those relating to recommended heat settings.



Avoid using thin, badly dented or distorted saucepans.  
**Those with uneven bases should not be used.**

### **To Prolong The Life Of The Hotplates:**

Never use utensils with a skirt, e.g. a bucket.

Never use an asbestos mat.

Never leave the hotplates ON when not covered with a saucepan.

Ensure that both hob and saucepans are clean and dry before commencing cooking, to cleaning.

Follow the cleaning instructions very closely to keep the hob looking like new.

**If spillage occurs with sugar solutions, e.g. jams and syrups, it must be wiped from the hob before it sets and becomes hard, otherwise damage to the hob will occur.**

**Do not slide** utensils across the surface - always lift the utensil when placing it on, or removing it from the ceramic surface. Your ceramic top hob unit is sturdy when cold as well as when warm, and can sustain very heavy utensils.

However, like all hardened glass, it can be damaged by a sharp, concentrated blow, for example, a salt/pepper cellar which falls from a spice shelf above.

**If visible cracks appear in the surface, the appliance must be disconnected immediately.**

Spills can be removed with a plastic safety scraper, but we advise polishing afterwards with a cleaning agent.

Never place wet utensils on the ceramic surface. Make sure that there is no sand, salt or sugar on the hobs surface (sand causes scratches, while burnt sugar or salt can damage the ceramic surface).

### **WARNING**

- Aluminium foil and plastic vessels are not to be placed on hot surfaces.
- The surface may not be used for storage.

### **Warning!!**

It is inadvisable to look directly at a lit halogen zone, as this may cause damage to the eyes

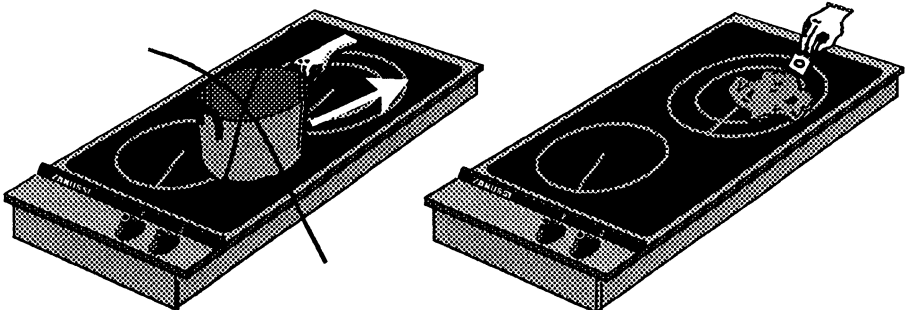

# INSTALLATION

## Unpacking

Check to see whether the unit is damaged.

The hob unit can be mounted in any type of kitchen with a table surface whose thickness is between 28-40 mm.

## Positioning

It is advisable to place the unit near an out-of-the-way, or closed corner, with space on either side on which to rest hot cooking utensils. The unit should not be placed on a heavily used corner, nor in a passageway.

**The hob unit is intended for normal household use only.**

It is important to follow the instructions set out in this instruction booklet in order to avoid damage to property, including the unit itself, and possible personal injury.

## Clearance

There must be a clearance of at least 45 mm. between the underside of the unit and the top surface of any fixture below.

## Fixing

Unscrew the fixing brackets so they can be moved and turned in under the worktop. Tighten the brackets onto the worktop with an ordinary screwdriver.

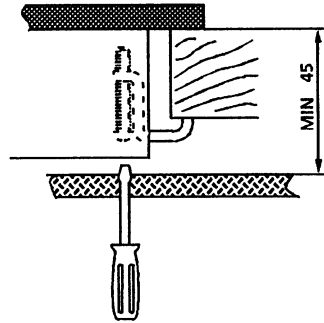

## Installation of a Single Unit

When mounting a single unit, be it a half or full-size unit, in a worksurface which is thicker than 30 mm. it is necessary to make a special notch in both sides of the cut-out hole, as illustrated.

The purpose of these notches is to create space for the electrical cables.

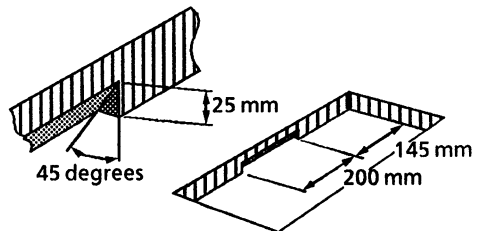

## Cut-out-Measurements

Recess measurements for installation of several DOMINO appliances:

One rectangular hole should be sawn out for the hob combination chosen.

**The depth of the the cut-out (front to back) for any unit is 490 mm.**

The length of the hole = sum of all units' externally measured length, less 20 mm.

### Example

Grill	290 mm.	+
Cooker hood	145 mm.	+
2 zone ceramic hob	290 mm.	+
2 burner gas hob	290 mm.	+
	(= 1015 mm.)	
<b>LESS 20 mm.</b>	<b>= 995 mm.</b>	

### The unit's total external lengths:

Cooker hood	145 mm.
Grill	290 mm.
2 plate hob	"
2 zone ceramic hob	"
2 burner gas hob	"
4 plate hob	580 mm.
4 zone ceramic hob	"
4 burner gas hob	"

## Mounting Of Reinforcement Beams

A reinforcement beam, with supporting flanges at each end is included with each 145 mm. and 290 mm. unit.

For unit combinations, a reinforcement beam must be used between each unit. It is not necessary to attach the reinforcement beam to the worktop, as it is held in place by a specially designed moulding, which is incorporated in the unit's flanges.

Minimum distance to wall: 150 mm.

Minimum distance to wall (non-flammable material): 50 mm.

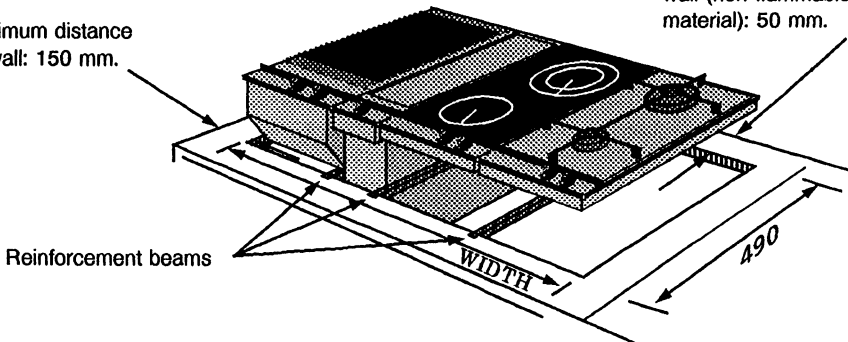

# ELECTRICAL CONNECTIONS

The electrical installation should only be performed by an authorised and fully trained electrician. The electrical installation must be carried out in accordance with prevailing regulations for appliances using heavy current. The installation must comply with any specific requirements specified by the local electricity authority.

**It is dangerous to tamper with or alter the specifications of this hob.**

The factory guarantee is rendered null and void in cases of faulty connection and in cases of interference with the unit's electrical parts.

The cable has to be mounted in the pegs as shown (cable min. 1,5 mm<sup>2</sup>, fuse type min. 15 Amp).

Unscrew the cover knob while connecting the cables.  
A unit is led directly to the power point or outlet rose.  
More units can be connected via one or more junction boxes.  
The combination of units must be connected via an external switch with a contact separation of at least 3 mm. in each pole.

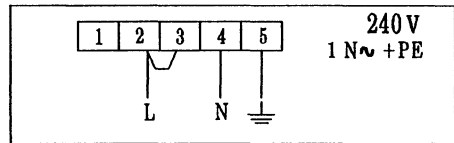

## OPERATING INSTRUCTIONS

1) Front view



2) Plan view Pilot light

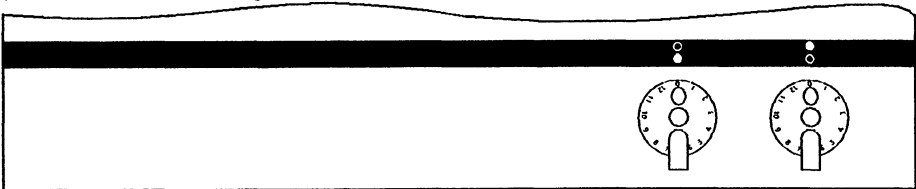

**Switch symbols (to the right)**

● Switch for regulating the double zone at the rear.

○ Switch for regulating the small zone at the front.

### Regulating

The heat regulation is graduated on both plates on a scale from 1-12.

1 - represents minimum heat.

12 - represents maximum heat.

■ - represents OFF.

**Small circle:** When you switch on the cooking section it will always be the small circle that is switched on. Choose the wanted temperature.

**From small to big circle (both circles are on):** Turn the button past "12" to stop. Turn back to the wanted temperature.

**From big to small circle:** Turn the button back to "0". Switch on again and choose the wanted temperature.

### **Residual Heat Indicator**

Each plate has a built-in indicator light which remains activated as long as the temperature of the plate exceeds 65°C, even when the plate is switched OFF.

The hob is fitted with a hot hob indicator light which illuminates when the hob is too hot to touch. The light will go OFF when the hob has cooled.

### **Pilot Light**

Pilot light activated when either of the hobs switches remain switched ON.

### **Deep Fat Frying**

For safety purposes, when deep fat frying, fill the pan 1/3 full of oil. **DO NOT COVER** the pan with a lid and **DO NOT** leave the pan unattended.

**In the event of a fire, switch OFF at the electricity supply and cover the pan with a lid or damp cloth to assist in smothering the flames.**

**Do NOT use water on the fire. Leave the pan to cool for at least 30 minutes before moving it.**

Do NOT leave the fat or oil in the frying pan on the hob to store it in case the hob is inadvertently switched ON.

### **1. Preparing The Food**

Seal the food by coating with flour, egg and bread crumbs or batter. Do not use a basket with batter coated foods as they will stick.

### **2. Quantity Of Oil**

For safety purposes, fill the pan only 1/3 full of oil.

### **3. Testing The Temperature Of The Oil**

It is advisable to use a thermometer to test the temperature of the oil. Alternatively, drop a small cube of bread into the oil which should brown in just under a minute if the oil is at the correct temperature, or 190°C/375°F.

### **4. Cooking The Food**

Lower the food gently into the oil. Do not add too much food at once or the temperature of the oil will be reduced and may result in soggy, greasy food. Turn the food if necessary, doughnuts float to the surface so will not brown on the upperside if not turned. Once cooked, drain the food on absorbent paper.

### **5. Double Frying Chips**

Double frying will ensure good chips. First fry the chips for a few minutes at 170°C/340°F to finish cooking and brown the chips.

Chips may be kept for several hours after the first frying before finishing off with the second frying.

## 6. Frying temperatures

	Celsius	Fahren- heit
	(°C)	(°F)
First frying of potatoes	170	340
	175	350
	180	360
Second frying of potatoes	190	375
Frying chicken and fish	195	380
	200	390

## Preserving

### 1. Pan size

Do not use a pan that overlaps the perimeter of the hob trim.

### 2. Filling the pan

To allow for a full rolling boil, the pan should be no more than 1/3 full when all the ingredients have been added. It is better to use two pans rather than overfill one, or use half quantities.

### 3. What to use

Use firm fruit or vegetables and wash well before using.

## 4. Types of sugar

Preserving sugar gives clear jam, however granulated sugar is cheaper and gives equally good flavour.

## 5. Crystallization

Crystallization may be caused if sugar is not completely dissolved before bringing the jam to the boil.

Over boiling will affect the flavour, setting properties and colour of the jam.

## 6. To test jam for setting

If a jam thermometer is available, boil the jam to 140°C. Marmalade should be boiled to 106°C.

If no thermometer is available, remove the pan from the heat, place a sample of jam on a cold dish and cool quickly (i.e. in a freezer or frozen food compartment of a refrigerator). When cold, and if it is ready, it should crinkle and hold the mark of a finger run through it.

## 7.

The scum should be removed as soon as possible after setting, but marmalade should be allowed to cool before decanting into jars to prevent the peel rising.

## IF THE UNIT DOES NOT WORK

We strongly recommend that you carry out the following checks on your cooker before calling a Service engineer. It may be that the problem is a simple one, which you can solve yourself without the expense of a Service call.

### If The Unit Does Not Work

Check that the unit is plugged in and the electrical supply is switched on.  
Check that the R.C.C.B. has not tripped

(if fitted).

Check that the mains fuse has not blown.

**If the problem is not the fuse or R.C.C.B., do not attempt to correct it yourself. Instead, contact your local Zanussi Service Centre, whose address can be found in the Customer Care booklet included with your hob. All repairs must be carried out by qualified personnel.**

# PEACE OF MIND FOR 24 MONTHS

## Standard guarantee conditions

This guarantee is in addition to your statutory and other legal rights which will not be excluded or in any way diminished by the return of the guarantee card.

We, Zanussi Ltd., undertake that if, within 24 months of the date of the purchase, this ZANUSSI appliance or any part thereof is proved to be defective by reason only of faulty workmanship or materials, the company will, at its option, repair or replace the same **FREE OF ANY CHARGE** for labour, materials or carriage on condition that:

- The appliance has been correctly installed and used only on the electricity supply stated on the rating plate.
- The appliance has been used for normal domestic purposes only, and in accordance with the manufacturer's operating and maintenance instructions.
- The appliance has not been serviced, maintained, repaired, taken apart or tampered with by any person not authorised by us.

All service work under this guarantee must be undertaken by a Zanussi Service Centre.

Home visits are made between 8.30am and 5.30pm Monday to Friday. Visits may be available outside these hours in which case a **premium** will be charged.

Any appliance or defective part replaced shall become the property of this company.

## Exclusions

This guarantee does not cover:

- Damage or calls resulting from transportation improper use or neglect, the replacement of any light bulbs or removable parts of glass or plastic.
- Costs incurred for calls to put right machines improperly installed or calls to machines outside the United Kingdom.
- Appliances found to be in use within a commercial or similar environment, plus those which are the subject of rental agreements.
- Products of Zanussi manufacture which are NOT marketed by Zanussi Ltd.

EU countries - The standard guarantee is applicable but subject to the owner's responsibility and cost to ensure the appliance meets the standards set by the country to which the product is taken. The Zanussi Company in the country concerned will be pleased to advise further. Sight of your purchase receipt will be required by them.

**ZANUSSI**