



EU2SYS-48 SERIES

HEATED DISPLAY SYSTEMS



• HALO HEAT ... a controlled, uniform heat source that gently holds and surrounds food for better appearance, taste, and longer holding life.



EU2SYS-48
FRONT VIEW
SHOWN WITH
OPTIONAL CASTERS



EU2SYS-48
BACK VIEW SHOWN WITH
750-TH-II COOK AND HOLD OVEN
AND OPTIONAL CASTERS

- Holds and displays hot food fresh and moist for hours — without adding water.
- Expandable system to meet your specific requirements.
- **HOT DISPLAY CASE**
 - Curved glass styling.
 - Displays hot food without condensation on glass.
 - Tempered sliding glass doors reflect heat back into the products and mirror the display to enhance merchandising effect.
 - Holds a full range of standard (gastronorm) pan sizes, full-size or half-size sheet pans.
 - Standard stainless steel front and black painted end panels.
 - Thermostatically controlled heat source radiates from the base of the display case in multiple heat zones.
 - Overhead light zones with shatterproof coated bulbs.
- **DECORATOR BASE**
 - Designed to accommodate your choice of equipment (750-TH-II, 750-TH-II/D, 750-S, 500-2D) or optional shelf.
 - Stainless steel, distinctively framed in black as standard and brushed stainless or custom color as alternate choices.
- **SELF-SERVICE HOT DISPLAY**
 - Customer self-service opening is available across the full length of case.
 - Front mounted heat-guard provides customer protection.

The display case is constructed of 18 gauge, non-magnetic stainless steel. A curved, tempered glass front encloses the display case and can be lifted to a 90 degree angle for easy cleaning. Removable, sliding glass doors on the operator side are included. Sliding door tracks have a "clean sweep" cutout allowing for easy cleaning and crumb removal. Framed end clear glass with rubber gasket material protects glass edges from chipping and breakage. The base is divided into two (2) individually managed heat zones with each zone controlled by a separate thermostat with a range of 1 through 10 and heat-on indicator light. Overhead lights are controlled by ON/OFF switches in two (2) light zones. Two (2) 125V plug outlets are available as an option on 120/208-240V units only.

- EU2SYS-48 - 48" (1219mm) length, with BU2 base,
-
- EU2SYS-48/P - 48" (1219mm) length, with BU2 base, 47-5/16" (1202mm) self-service opening across full length of case front

FACTORY INSTALLED OPTIONS

- The system base is not sold as a separate item. Order the full EU2SYS model to receive the base.
- Panel Color Choices
 - Specify color choice:
 - Black, standard
 - Stainless Steel, optional
 - Custom Color, optional



W164 N9221 Water Street • P.O. Box 450 • Menomonee Falls, Wisconsin 53052-0450 • U.S.A.
PHONE: 262.251.3800 800.558.8744 U.S.A./ CANADA FAX: 262.251.7067 800.329.8744 U.S.A. ONLY

www.alto-shaam.com

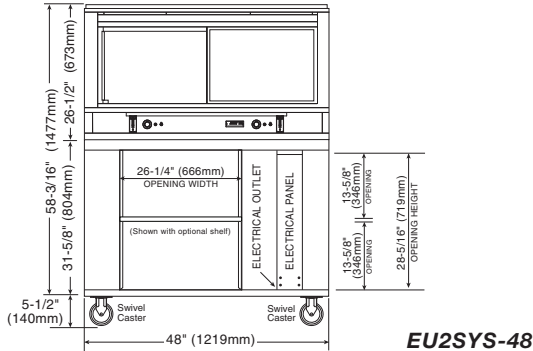
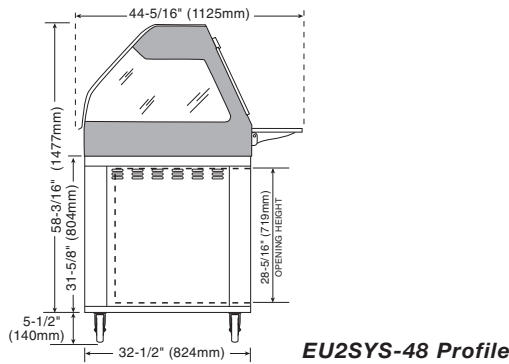

DIMENSIONS (H X W X D)	
EXTERIOR, WITH BASE: 58-3/16" x 48" x 44-5/16" (1477mm x 1219mm x 1125mm)	
WELL DIMENSIONS (W X L X D): 27-3/16" x 45-5/16" x 4-1/2" (690mm x 1151mm x 114mm)	

ELECTRICAL					
VOLTAGE	PHASE	CYCLE/HZ	AMPS	kW	
120/208-240 (UL)	1	50/60	13.8	3.3	
at 208	1	50/60	11.6	2.5	BARE END, NO PLUG
at 240	1	50/60	13.0	3.1	
230 (CE)	1	50/60	12.6	2.9	
230	1	50/60	12.6	2.9	BARE END, NO PLUG

PAN CONFIGURATION*			
PAN SIZE	DIMENSIONS	QTY.	
FULL-SIZE & ONE-THIRD**:	12" x 20" x 2-1/2" (GN 1/1)	3	
	12" x 6" x 2-1/2" (GN 1/3)	3	
HALF-SIZE & ONE-THIRD**:	12" x 10" x 2-1/2" (GN 1/2)	6	
	12" x 6" x 2-1/2" (GN 1/3)	3	
FULL-SIZE SHEET PANS:	18" x 26" x 1"	2	
MAX. CAPACITY/VOLUME:	48 lbs (22 kg) 30 qts (36 L)		

* Pans are not included with display case.
** Will also accept 4" (100mm) deep pans.

SPECIFICATIONS	
• Six (6) overhead lights with two (2) light zones.	
• Two (2) base heat zones with two (2) adjustable thermostats with a range of 1 through 10, and two (2) heat-on indicator lights.	
• Two (2) tinted, reflective, tempered glass sliding doors on operator side.	
• One (1) 10" x 36" (254mm x 914mm) operator-side work shelf.	
• Self-serve model EU2SYS-48/P has a self-serve pan insert 26-7/16" x 45-3/16" x 2" (672mm x 1148mm x 51mm) and includes two (2) Wire Pan Grids.	

INSTALLATION REQUIREMENTS

Display case must be installed level. The display case must not be installed in any area where it may be affected by steam, grease, dripping water, high temperatures, or any other severely adverse conditions.

Do not install a heated display case near a cold air source such as a freezer, air conditioning vents, or in any area where outside air fluctuation can affect performance.

WEIGHT (EST.)		
MODEL	NET	SHIP
EU2SYS-48	612 lb (278 kg)	645 lb (293 kg)
EU2SYS-48/P	613 lb (278 kg)	650 lb (295 kg)

CRATED DIMENSIONS: H X W X D
EU2SYS-48: NOT YET AVAILABLE

OPTIONS & ACCESSORIES	
<input type="checkbox"/> CARVING STATION	5001874
CASTERS, PLATE	
<input type="checkbox"/> 5" (127mm), RIGID (2 REQUIRED)	CS-2025
<input type="checkbox"/> 5" (127mm), SWIVEL WITH BRAKE (2 REQUIRED)	CS-2026
<input type="checkbox"/> GAUGE, INTERIOR AMBIENT TEMP.	5008527
<input type="checkbox"/> GLASS, TEMPERED END PANE, BRONZE KIT	5001143
<input type="checkbox"/> INDEPENDENT ELECTRICAL OUTLET	5001781
<input type="checkbox"/> LOW PROFILE BASE	
OVERALL HEIGHT REDUCED BY 4-3/4" (121mm)	304332
PANEL KIT, COUNTER TOP	
<input type="checkbox"/> BRUSHED STAINLESS STEEL	5001281
<input type="checkbox"/> CUSTOM COLOR	P148
PANEL KIT, SYSTEM	
<input type="checkbox"/> BRUSHED STAINLESS STEEL	5001287
<input type="checkbox"/> CUSTOM COLOR	5005788
<input type="checkbox"/> PAN INSERT, SELF-SERVICE 4" (102mm) DEEP	1001990
PLATFORM SCALE	
<input type="checkbox"/> LEFT-HAND	5001308
<input type="checkbox"/> RIGHT-HAND	5001307
<input type="checkbox"/> SHEET PAN DIVIDER BAR PACKAGE	5002802
<input type="checkbox"/> SHELF, STAINLESS STEEL	5005786
<input type="checkbox"/> TEMPERATURE PROBE	5004916
<input type="checkbox"/> THERMOSTAT GUARD COVER PLATE	5007660
<input type="checkbox"/> WORK SHELF WITH GRAVY LANE	5005638