

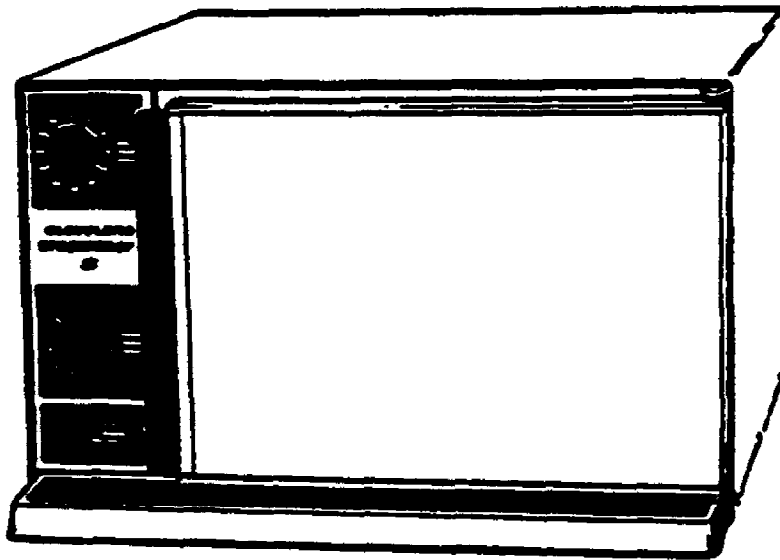

Service Manual

**STEAMCRAFT II
COUNTER TYPE CONVECTION STEAMER**

MODELS: CET-5



STEAMCRAFT II MECHANICAL COMPONENTS

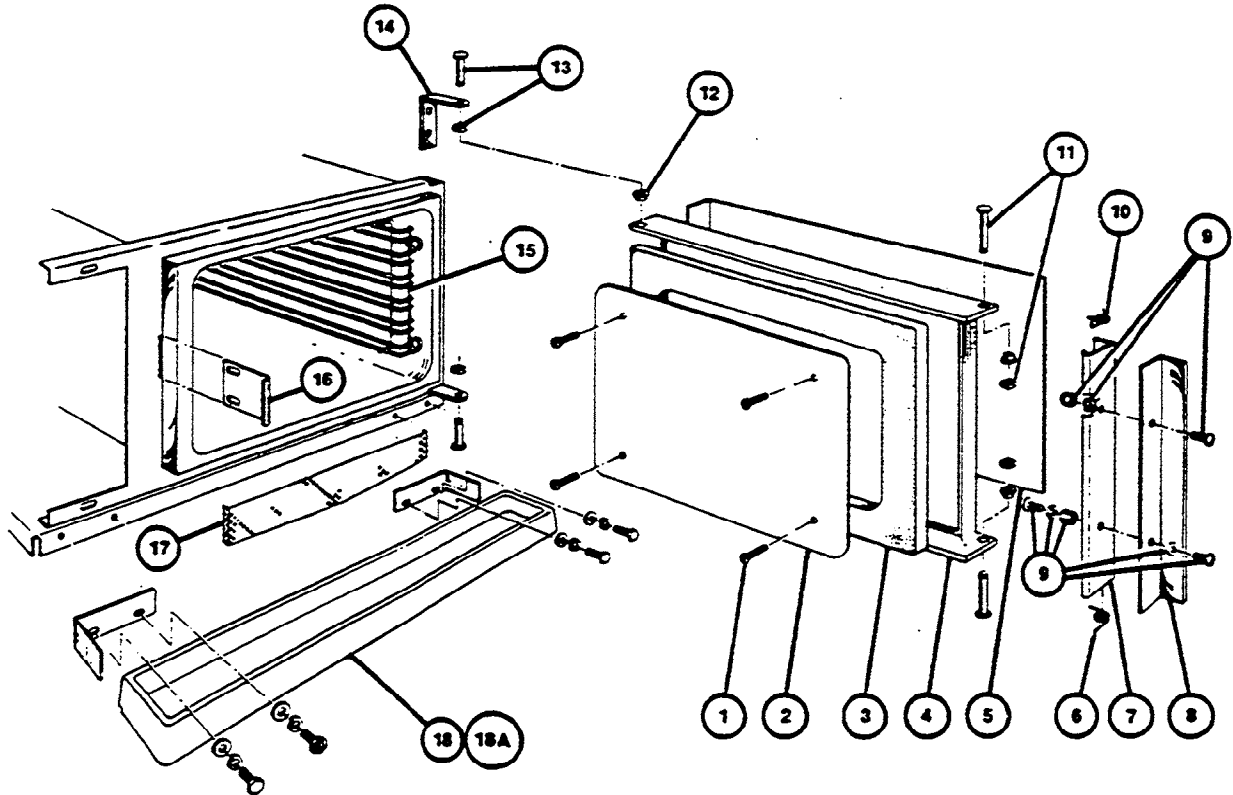

REFERENCE NUMBER	PART NUMBER	DESCRIPTION
1	19177	Sealing Screw (4 required)
2	66651	Gasket Retainer Plate
3	07138	Gasket, Door
4	04172	Door Casting
5	44039	Door Cover
6	19578	Lower Door Spring
7	44037	Latch
8	58110	Handle
9	44040	Handle Mounting Hardware
10	19577	Upper Door Spring
11	40589	Latch Pin & Retainer (2 required)
12	02624	Bushing
13	40588	Hinge Pin & Retainer (2 required)
14	58198	Hinge
15	41423	Slide Assembly
16	62201	Strike
17	41101	Drain Screen (used on units built before July 31, 1982)
	41102	Drain Screen (used on units built after Aug. 1, 1982)
18	20602	Drip Trough — Plastic
18A	20601	Drip Trough — Aluminum (Not Shown — Used only on units built before Aug. 20, 1979)

CLEVELAND RANGE, INC. 1333 EAST 179th ST., CLEVELAND, OHIO 44110
 Manufacturer reserves right of design improvement or modification, as warranted.

STEAMCRAFT II ELECTRICAL COMPONENTS

DATE OF MANUFACTURE: JAN. 31, 1979 THRU JULY 31, 1982

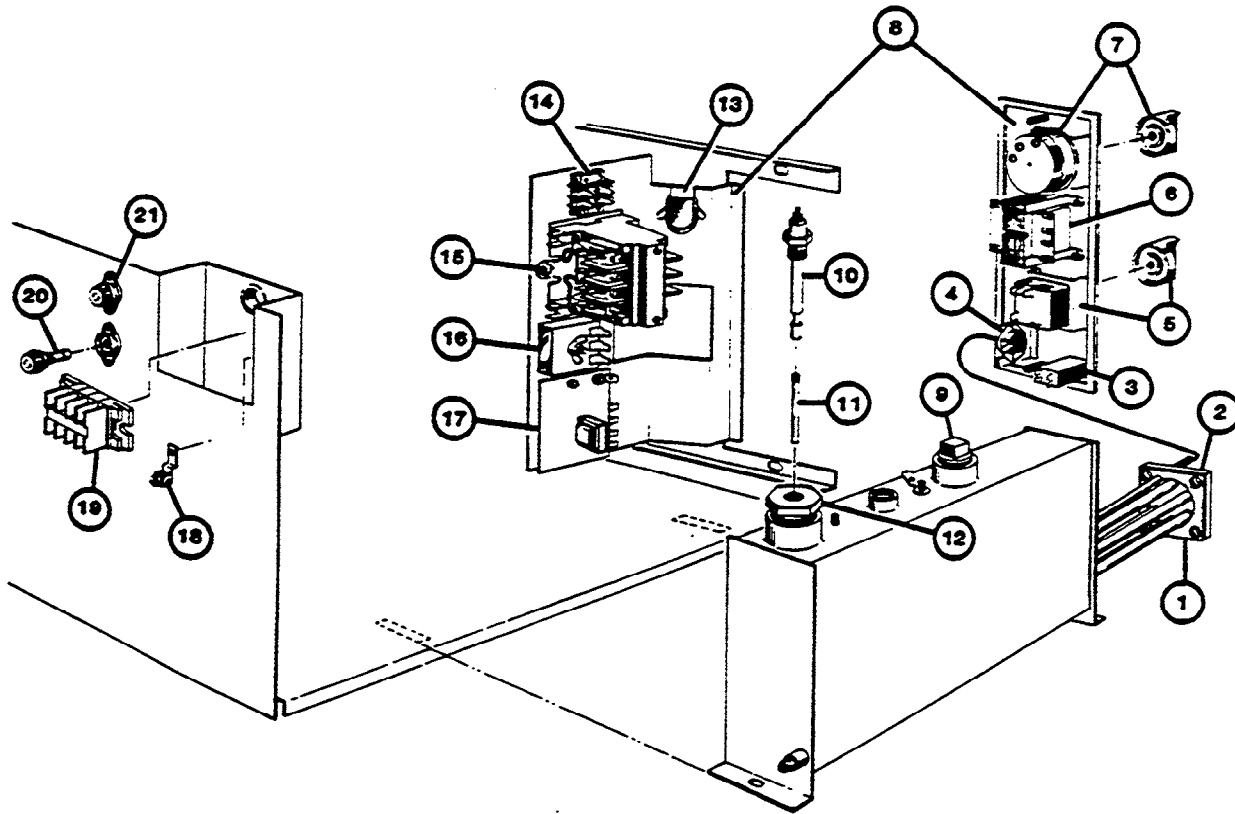

REFERENCE NUMBER	PART NUMBER	DESCRIPTION
1	07142	Heater Gasket
2	08226	208-220V Heater, Immersion 5KW
	08225	240V Heater, Immersion 5KW
3	19981	"Water On" Switch (on-off power switch)
4	19980	Heater Protection Switch
5	40728	Steam Control With Knob
6	20533	Transformer, 75 VA
7	43905	Timer With Knob
8	43956	Panel Assembly
9	16609	1" Brass Plug
10	40462	Probe, Single
11	62459	Probe Extension
12	02626	Adaptor Bushing
13	41350	Buzzer
14	43908	Terminal Block
15	03518	Contactor, 4 Pole, 30 Amp
16	20477	Timer, Solid State
17	23195	Water Level Control
18	12330	Ground Lug
19	43909	Terminal Block — Main Power
20	06340	Fuse
21	06341	Fuse Holder
	14908	Label (not shown)

CLEVELAND RANGE, INC. 1333 EAST 179th ST., CLEVELAND, OHIO 44110
 Manufacturer reserves right of design improvement or modification, as warranted.

STEAMCRAFT II ELECTRICAL COMPONENTS

DATE OF MANUFACTURE: AUG. 1, 1982 THRU PRESENT

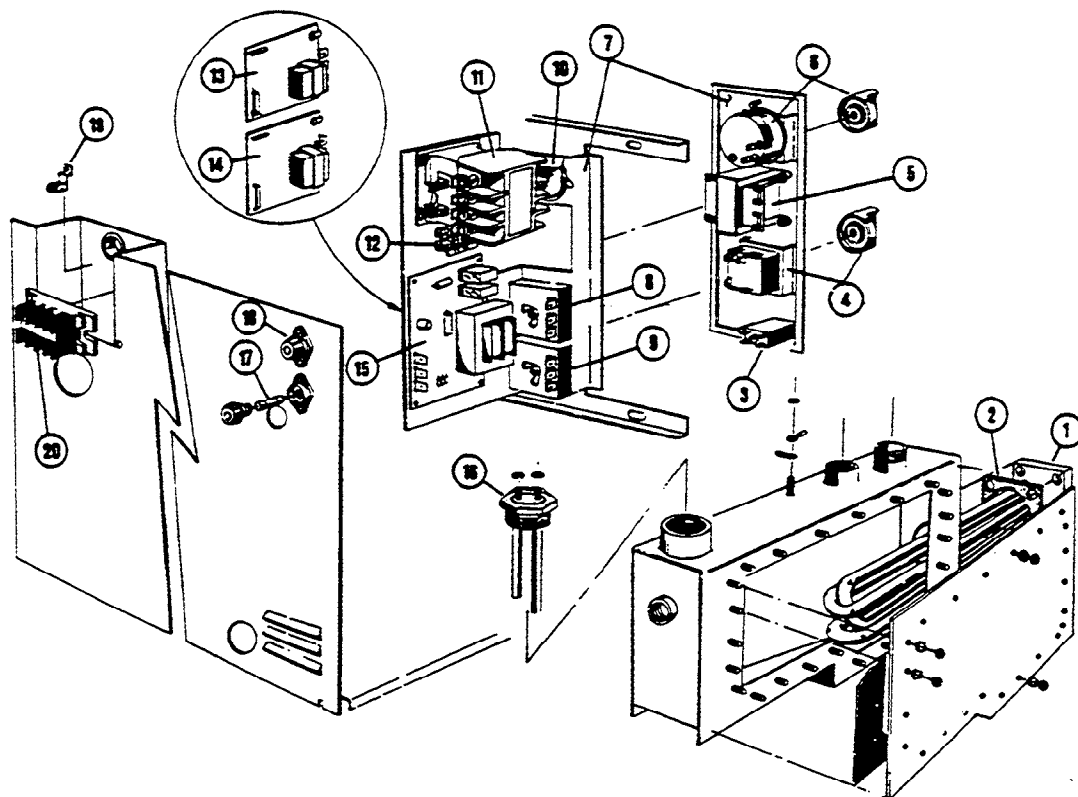

REFERENCE NUMBER	PART NUMBER	DESCRIPTION
1	08228	208V Heater, Immersion, 5KW
	08229	220-240V Heater, Immersion, 5KW
	08231	480V Heater, Immersion, 5KW
2	07128	Heater Gasket, 3" Square
3	19993	On-Off Power Switch
4	40728	Steam Control With Knob
5	20533	Transformer, 75VA
6	43905	Timer With Knob
7	43956	Panel Assembly (after 9/13/83)
	44049	Panel Assembly (from 8/1/82 through 9/12/83)
	14908	Label, Control Panel (not shown)
8	20477	Timer, Solid State, 3 Second (Buzzer)
9	20478	Timer, Solid State, 3 Minute (Water Flush)
10	41350	Buzzer
11	03518	Contactor, 4 Pole, 30 AMP
12	43908	Terminal Block
13	23195	Water Level Control Board (from 8/1/82 through 9/12/83)
14	03515	Low Water Cut-Off S/S Board (from 8/1/82 through 9/12/83)
15	23198	Water Control Board (after 9/13/83)
16	16673	Probe, Dual
17	06344	Fuse, 2 AMP, Type KTKR-2
18	06343	Fuse Holder
19	12330	Ground Lug
20	43909	Terminal Block-Main Power

CLEVELAND RANGE, INC., 1333 EAST 179th ST., CLEVELAND, OHIO 44110

Manufacturer reserves right of design improvement or modification, as warranted.

STEAMCRAFT II PIPING COMPONENTS

STYLE A — DATE OF MANUFACTURE: JAN. 31, 1979 thru DEC. 10, 1980

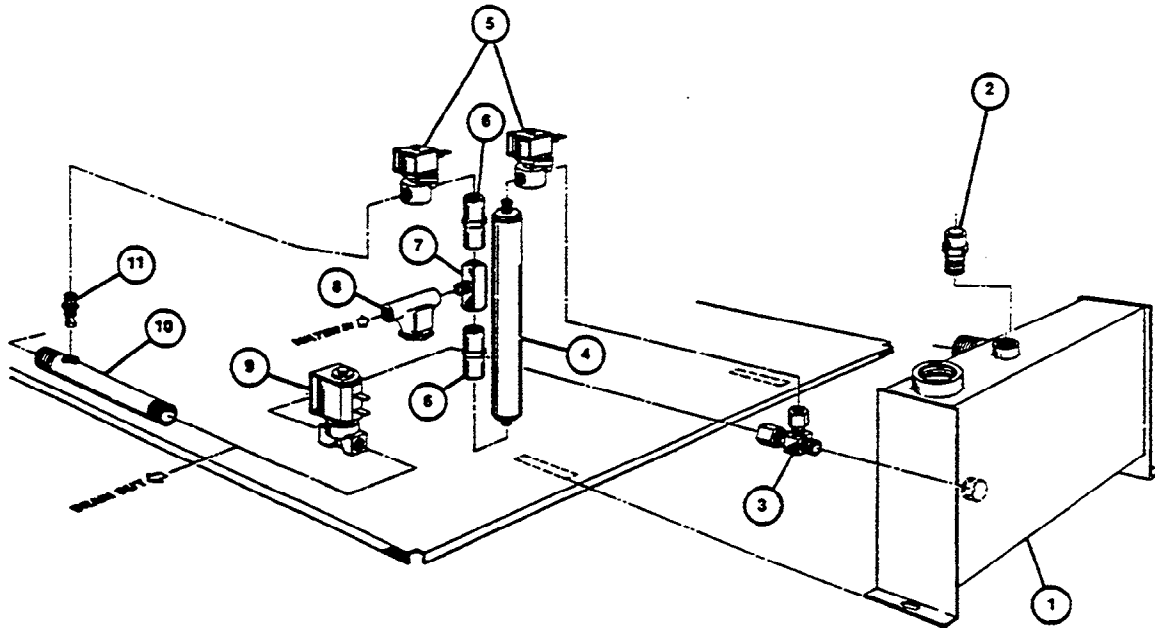

REFERENCE NUMBER	PART NUMBER	DESCRIPTION
1	43657	Generator with Insulation
2	22216	Safety Valve — 1 PSI
3	06188	Tee Tube Fitting
4	03350	Water Conditioner
5	22218	Valve, Water Solenoid
6	15463	Flow Regulator — ¼ GPM
7	20245	Tee Male Branch
8	19880	Strainer
9	22217	Valve, Drain Solenoid
10	16478	Drain Pipe
11	14497	Condenser Nozzle

CLEVELAND RANGE, INC. 1333 EAST 179th ST., CLEVELAND, OHIO 44110

Manufacturer reserves right of design improvement or modification, as warranted.

STEAMCRAFT II PIPING COMPONENTS
STYLE B — DATE OF MANUFACTURE: DEC. 11, 1980 thru JULY 31, 1982

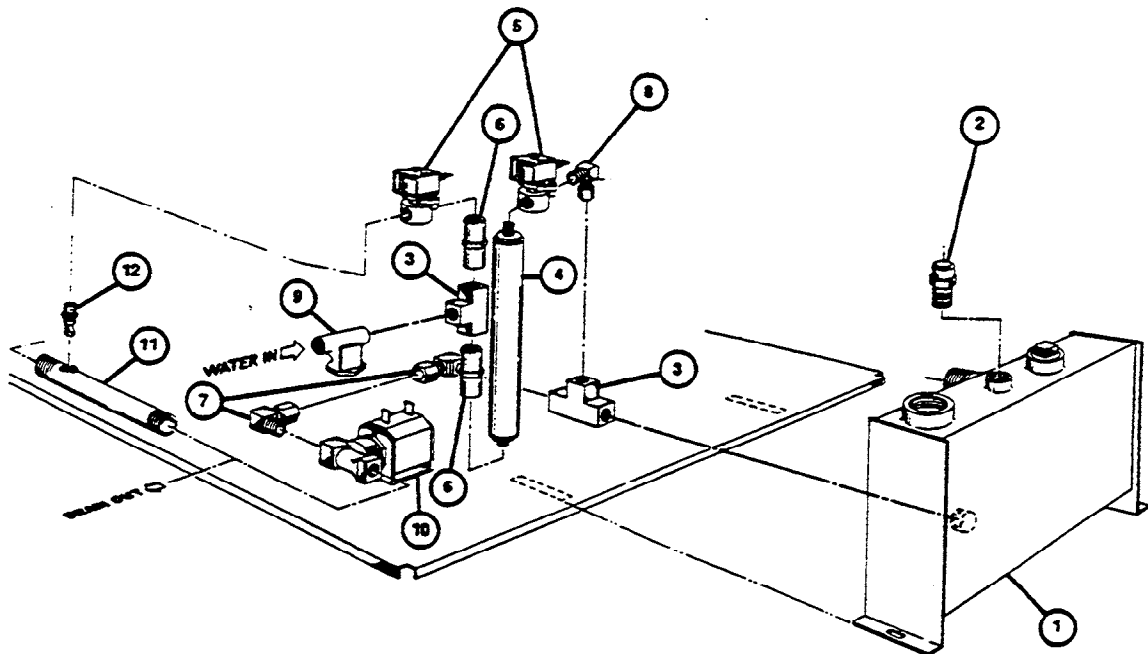

REFERENCE NUMBER	PART NUMBER	DESCRIPTION
1	43657	Generator with Insulation
2	22216	Safety Valve — 1 PSI
3	20199	1/4" Tee
4	03350	Water Conditioner
5	22218	Valve, Water Solenoid
6	15463	Flow Regulator — 1/4 GPM
7	06196	3/8 Tee x 1/4 MPT, 90° Compression Fitting
8	06214	1/4 Tee x 1/4 MPT, 90° Compression Fitting
9	19880	Strainer
10	22217	Valve, Drain Solenoid
11	16478	Drain Pipe
12	14497	Condenser Nozzle

CLEVELAND RANGE, INC. 1333 EAST 179th ST., CLEVELAND, OHIO 44110

Manufacturer reserves right of design improvement or modification, as warranted.

STEAMCRAFT II PIPING COMPONENTS

STYLE C—DATE OF MANUFACTURE: AUG. 1, 1982 THRU PRESENT

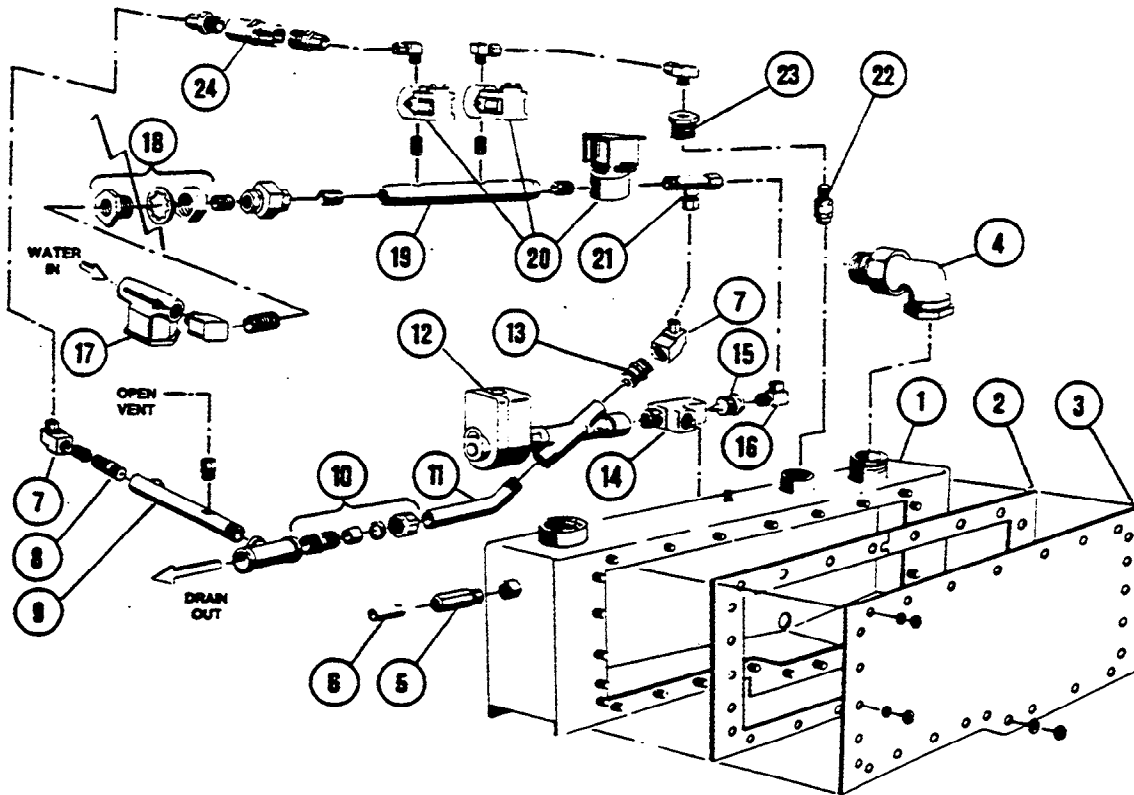

REFERENCE NUMBER	PART NUMBER	DESCRIPTION
1	43658	Generator With Insulation and Cover
2	07143	Generator Cover Gasket
3	66586	Generator Cover
4	05263	EII, Radiator Union
5	22222	Safety Valve
6	14480	Nipple, 3/8" x 1 1/4" Threaded One End
7	06227	1/4" Tube x 1/4" FPT, 90° Compression Fitting
8	14553	Nozzle, Spray, Compartment Drain
9	16482	Drain Manifold, Compartment
10	03395	Flexible Drain Pipe Connector
11	16481	Drain Pipe, Generator
12	22221	Valve, Drain, Special Solenoid
13	14551	Nozzle, Jet, Generator Drain
14	20247	1/2" Male Run Tee
15	14554	Nozzle, Jet, Generator Drain
16	06192	1/4" Tube x 1/4" MPT, 90° Compression Fitting
17	19870	1/4" Line Strainer
18	03641	Bulkhead Coupling
19	16480	Water Line Manifold
20	22218	Valve, Water Solenoid
21	06188	1/4" Tube Fitting, Male Run Tee
22	14552	Nozzle, Spray, Generator Drain
23	02549	Condenser Bushing
24	15463	Flow Regulator, 1/4 GPM (from 8/1/82 through 11/30/83)

NOTE: FOR SAFETY PURPOSES, DRAIN SCREEN COVER MUST BE IN PLACE WHEN OPERATING EQUIPMENT.

CLEVELAND RANGE, INC., 1333 EAST 179th ST., CLEVELAND, OHIO 44110

Manufacturer reserves right of design improvement or modification, as warranted.

THIS UNIT IS WIRED FOR THREE PHASE OPERATION AT THE FACTORY. FOR SINGLE PHASE OPERATION CHANGE JUMPERS TO THAT SHOWN BELOW.

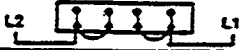

SINGLE PROBE UNIT
7/29/79 thru 8/1/82

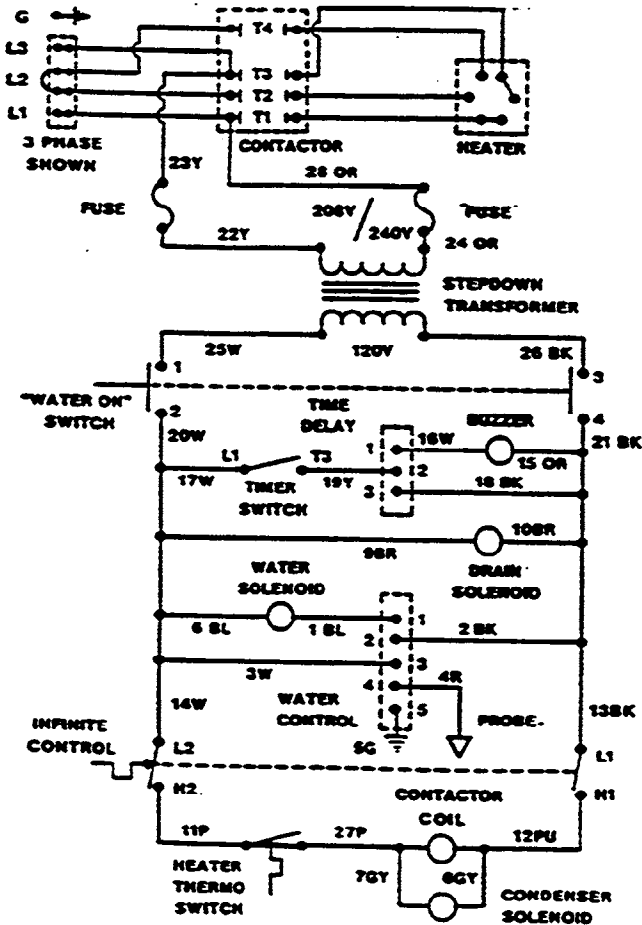

DO NOT ATTEMPT ANY MAINTENANCE UNLESS THE ELECTRIC SUPPLY HAS BEEN COMPLETELY DISCONNECTED. IF A DISCONNECT SWITCH HAS NOT BEEN PROVIDED, REMOVE ALL FUSES FROM THE CIRCUIT AND LOCK THE FUSE PANEL SO THAT THE FUSES CANNOT BE ACCIDENTALLY REPLACED.

THIS UNIT IS WIRED FOR THREE PHASE OPERATION AT THE FACTORY. FOR SINGLE PHASE OPERATION CHANGE JUMPERS TO THAT SHOWN AT RIGHT.

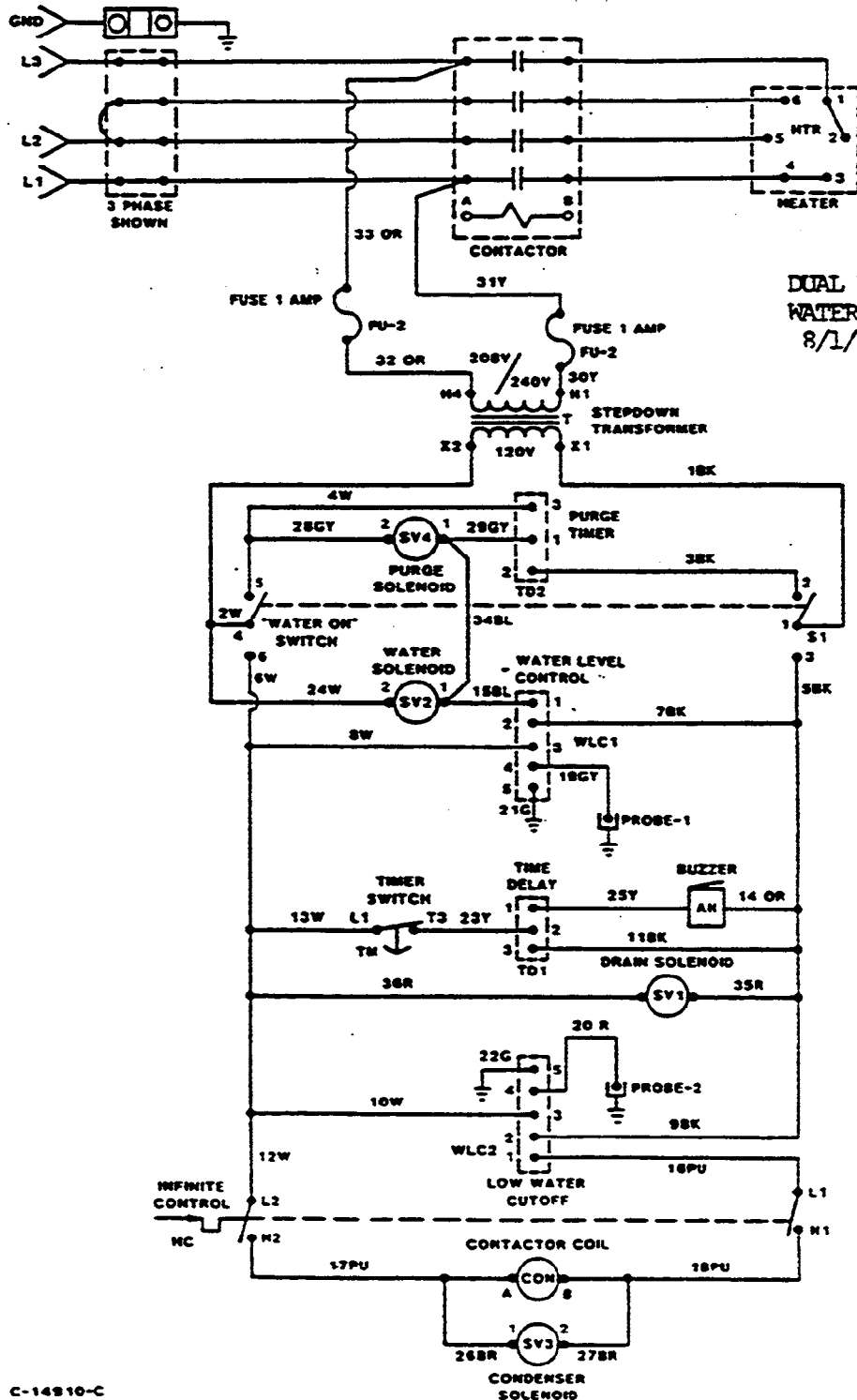
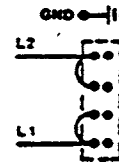

DUAL PROBE UNIT WITH TWO WATER BOARDS
8/1/82 thru 9/12/83

STEAMCRAFT II
 208V & 220/240V (ONLY)
 WIRING DIAGRAM

WARNING:
 DO NOT ATTEMPT ANY MAINTENANCE UNLESS THE ELECTRIC SUPPLY HAS BEEN COMPLETELY DISCONNECTED. IF A DISCONNECT SWITCH HAS NOT BEEN PROVIDED, REMOVE ALL FUSES FROM THE CIRCUIT AND LOCK THE FUSE PANEL SO THAT THE FUSES CAN NOT BE ACCIDENTALLY REPLACED.

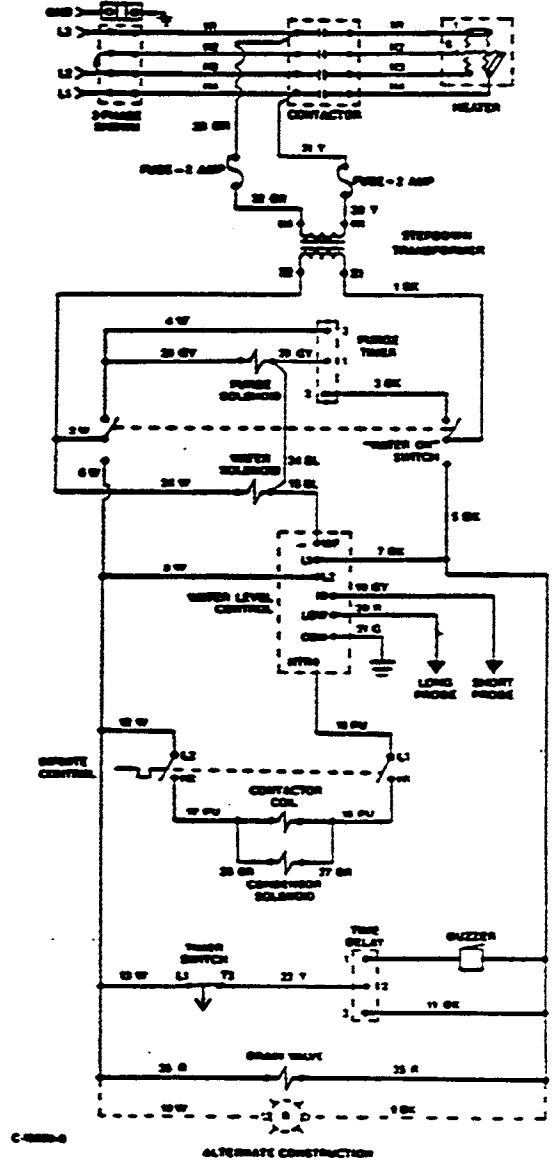
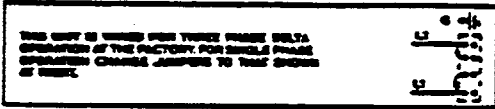

CLEVELAND RANGE DESCALING KIT
INSTRUCTIONS FOR CHEMICALLY DESCALING A
STEAMCRAFT II EQUIPPED WITH A DUAL PROBE

For a thorough understanding of proper procedures and precautions, read these instructions completely before proceeding.

IMPORTANT

Before using this acid descaling product, read the safety precautions and first aid instructions found on the container label.

Steamcraft II steamers produced after August 1, 1982 are equipped with removable side panels on the outside wall of the steam generator for ease of cleaning in addition to chemically descaling. Peel off the tape securing the generator side wall insulation, then swing the insulation upward to access the generator removable side panel. Remove the lockwashers and nuts securing the removable panel, then remove the panel and gasket. Using a scoop, or a tablespoon, or by hand, remove scale build-up from the generator. Install a new gasket, then replace the side panel, securing it with the lockwashers and nuts to 30 inch-pounds torque. DO NOT OVER-TORQUE THE NUTS, as the studs will break off. There is never any pressure in the generator, and therefore, the nuts do not require heavy torquing to create a water-tight seal.

PREPARATION:

The plastic jar of descaling compound contains 10 pounds of sulfamic acid as a base chemical, plus a specially formulated blend of a corrosion inhibitor, wetting agent, and color-change pH indicator to improve cleaning effectiveness in removing hard water scales and other deposits. This product is water soluble and its solution performs most efficiently when maintained at temperatures of 150 - 160°F (65 - 71°C). Also included is an 8 ounce poly-bag of soda ash (sodium carbonate) neutralizer.

Effective descaling and neutralizing of the Steamcraft II steam generator is generally accomplished by using 1 pound of descaling powder (1/10 of the plastic jar's contents) and 1 ounce of neutralizer (1/8 of the poly-bag's contents).

WARNING: Steam and hot water may cause serious injury and bodily harm when it is accidentally or carelessly released. Improper handling of acid could cause serious, permanent injury. Therefore, service of the steam generator should only be performed by trained and experienced personnel, thoroughly familiar with servicing generators.

Mix approximately 1 ounce (1/8 of the poly-bag's contents) of soda ash neutralizer in 1 cup of water. Bicarbonate of Soda or baking soda are suitable alternative neutralizers. Keep this solution nearby to be used to neutralize acid that may be accidentally spilled.

Turn off electrical power to the steamer at the main fused disconnect power switch. Remove the six screws (3 left & 3 right) along the lower left and right edges of the once piece outer sheeting. Lift the outer sheeting straight up and off the steamer.

GENERATOR DESCALING

Locate the generator probe (top rear of generator). Remove the low water probe wire (red) and water level probe wire (grey) from the probe terminals. Isolate probe wires to prevent inadvertent grounding until required for reconnection. Remove the probe from the top of the generator.

Inspect the generator and probe to determine the severity of mineral scale build-up. If build-up is considerable, side panel removal may be required. Using a fine grid emory paper remove any scale build-up on the probe extensions before reinstallation.

Pour the premeasured one pound of descaler into the generator via the probe coupling. Install the probe in generator and reconnect only the red probe wire.

Energize the electric power supply to unit and push power "ON" switch. The generator is now filling with water. Open the compartment door and watch the steam port for water flow. When water starts to enter compartment, reconnect grey generator probe wire. Water should stop flowing.

Turn the heat control switch to "10", setting. Once again view the compartment steam port for water flow, approximately 3 minutes. Turn the heat control switch to "0" when steam or water starts to gurgle from port.

Let the solution stand for several hours. The descaling process can range in time from a few hours, to overnight, depending upon the severity of the scale.

When the descaling process is complete, push the steamer's power switch to the "OFF" position to drain the generator of descaling solution.

GENERATOR FLUSH

Remove the two probe wires from the probe and isolate them. Remove probe from generator and examine the generator for any scale residue. Connect the grey probe wire to the "ground" connection on the top of the generator. Push the power on switch to the "ON" position. Pour the neutralizer solution into the generator probe coupling. Replace the generator probe and tighten securely, make sure that the probe terminals are parallel with the rear wall of the unit. Remove grey wire from ground terminal and isolate wire until required.

Generator is now filling with water and neutralizing solution. Observe the compartment steam port for water flow, approximately 45 seconds, and reconnect the grey wire to probe terminal. Allow solution to stand in generator for 5 minutes. Push the power switch to the off position to drain the generator.

Disconnect the grey wire from the probe and isolate it once more. Energize the power on switch and observe the compartment for water flow. De-energize the power switch when water appears in the compartment and allow unit to complete the purge cycle. Turn off main electrical supply to unit.

Reconnect red and grey probe wires to the proper terminals with their lockwashers and nuts. Re-energize the main fused power connection.

STEAMER TESTING

Test the steamer for proper operation. Push the power switch to the "ON" position. The red light will illuminate when the steamer is on. Turn the steam control knob to number "10". Leave the cooking compartment door open. Steam should begin to appear inside the cooking compartment after approximately 5 minutes. Inspect plumbing for leaks.

If the steamer is operational, push the power switch to the "OFF" position, then turn the steam control knob to zero.

Finally, reinstall the outer sheeting, securing it with the six screws.

TROUBLESHOOTING CHART

COMPLAINTS

POSSIBLE CAUSES

1. NO OPERATION
(POWER LIGHT OUT)

1. No power being supplied to terminal block.
2. Blown control circuit fuse in holder at rear of steamer.
3. Broken or burned off wire connection between terminal block and contactor.
4. Open stepdown transformer.
5. Faulty power switch.

3. PRODUCING NO STEAM
(CONTACTOR DOES ENERGIZE)

1. Open circuit in heating element.
2. Broken or burned wire connections between element and contactor.
3. Contacts not making good contact in contactor.

4. PRODUCING NO STEAM BUT
POWER LIGHT IS ON
(CONTACTOR DOES NOT ENERGIZE)

1. Steam control not turned on.
2. Faulty steam control switch.
3. Not enough water in generator.
(See : Generator Will Not Fill)
4. Faulty solid state liquid level control.
5. Open contactor coil.
6. Contactor physically stuck open.
7. Drain valve stuck open, not allowing generator to fill and activate low water cutoff probe.

TROUBLESHOOTING CHART

COMPLAINT

5. GENERATOR WILL NOT FILL WITH WATER WHEN POWER SWITCH IS ON

POSSIBLE CAUSES

- I. If power light is off :
 - A. Power switch
 - B. Power supply
 - C. Control fuse

- II. If power light is on and no voltage is measured across the fill solenoid coil :
 - A. If no voltage is measured across L1 & L2 on the level control board :
 1. Broken wire connection from power switch to level board.
 - B. If 120 volts is measured across L1 & L2 on the level control board and no voltage is measured from L2 to WF on the level board :
 1. Faulty level control board.
 2. Check for grounded probe.
 - C. If 120 volts is measured across L1 & L2 on the level control board and 120 volts is measured from L2 to WF on the level board.
 1. Broken wire connection from WF to water fill solenoid or from solenoid coil to transformer.

- III. If power light is on and 120 volts is measured across the fill solenoid coil.
 - A. Water supply off.
 - B. Fill solenoid clogged with scale.
 - C. Fill solenoid mechanically stuck.
 - D. Fill solenoid coil open.

TROUBLESHOOTING CHART

COMPLAINT

6. GENERATOR OVERFILLS & THE POWER SWITCH IS ON
(WATER RUNS OVER INTO THE COOKING COMPARTMENT FROM STEAM DISCHARGE)

POSSIBLE CAUSES

- I. If no voltage is measured across either the purge solenoid coil or the fill solenoid coil.
 - A. Foreign material or scale could be physically keeping the plunger from seating, thus allowing water to continually enter the generator through one of the solenoids.

- II. If 120 volts is measured across the purge solenoid coil.
 - A. Purge timer contacts are stuck closed.

- III. If 120 volts is measured across the fill solenoid coil.
 - A. Faulty liquid level control board.
 - B. Faulty probe.
 - C. Broken or poor ground connection to common terminal on level control board.
 - D. Broken or poor probe wire connection from level board to the probe.
 - E. Scale buildup on probe.
 - F. Heavy scale buildup in generator.

TROUBLESHOOTING CHART

COMPLAINTS

POSSIBLE CAUSES

7. WATER OVERFLOWS INTO
COOKING CHAMBER THROUGH
DRAIN AND/OR STEAM
DISCHARGE

1. Drain not open to atmosphere.
2. Drain line not minimum 1 inch size.
3. Drain manifold or fittings clogged with buildup or spilled food buildup.

Note : This condition is caused when the condenser water or purge water cannot exit through the drain quickly enough.

8. LOW STEAM OUTPUT

1. Element partially burned out.
Note : Resistance for each of 3 paths of element should be approximately :
31 ohms at 208 volts
36 ohms at 240 volts
48 ohms at 480 volts
2. Steam control switch set too low.
3. Excessive scale buildup on element reducing heat transfer to generator water.
4. Supply voltage not correct or too low.

9. EXCESSIVE ELEMENT FAILURE

1. Element tubes not split open or overheated.
 - a. Improper supply voltage.
 - b. High voltage spikes from power supply.
2. Element tubes split open or bright red from overheating.

*** THIS CONDITION CAN ONLY BE CAUSED WHEN THE ELEMENT IS ENERGIZED WITHOUT BEING IMMERSSED IN WATER.**

- a. Check condition of probe - make sure electrodes show no resistance to ground. (Probe body should be constructed of white teflon including threads). If probe has brass fitting or shows any deformity, replace it.

TROUBLESHOOTING CHART

COMPLAINTS

POSSIBLE CAUSES

9. EXCESSIVE ELEMENT FAILURE
(Continued)

- b. Excessive buildup of scale on element and in generator.
- c. Faulty level control board.
- d. Shorted wiring to ground from probe connections.
- e. Probe chamber scaled shut. (See drawing below)

GENERATOR

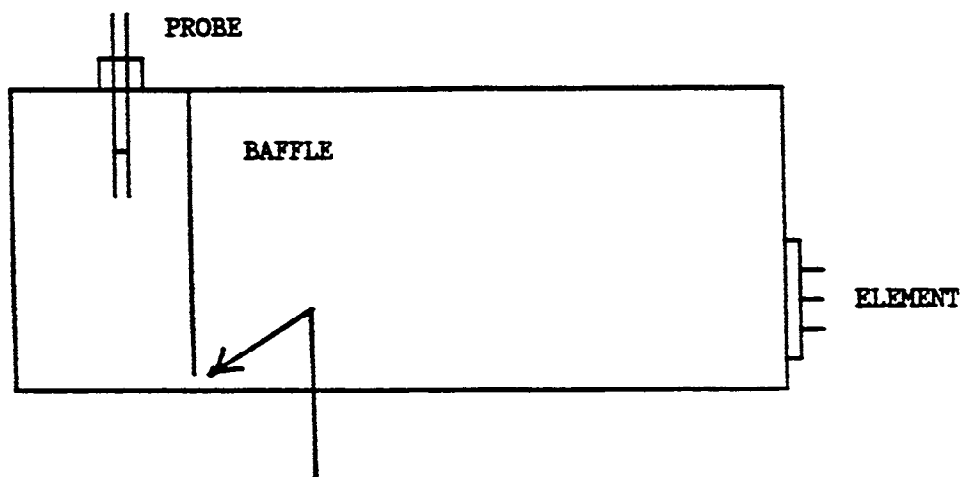

If this area becomes blocked from scale buildup, false water levels can be sensed by the electrodes. The generator must be delimed and cleaned. This is a fairly frequent cause of element failure.

TROUBLESHOOTING CHART

COMPLAINTS

POSSIBLE CAUSES

10. CONTACTOR NOISY WHEN
ENERGIZED

1. If the contactor is buzzing loudly, the armature in the contactor is not properly seated. This is usually do to warped Bakelite parts, or broken parts. Replace the contactor.
2. If the contactor is chattering loudly when it is energized or de-energized, one of the controls that energizes the contactor coil has poor contact. This is usually caused by the steam control switch.

11. CONTROL CIRCUIT FUSES
ON BACK OF STEAMER
CONTINUALLY BLOW

These fuses control only the control circuit components.

1. Shorted wiring in control circuit.
2. Contactor coil breaking down.
Coil resistance should be between 100 and 125 ohms (Gould Contactor).
3. Solenoid coil breaking down.
Water solenoid resistance should be between 575 and 640 ohms.
Drain solenoid resistance should be between 45 and 55 ohms.

If you find any of these components measuring resistances out of the ranges specified above, that component coil is breaking down and must be replaced.

TROUBLESHOOTING CHART

COMPLAINTS

POSSIBLE CAUSES

12. POWER SUPPLY CIRCUIT
BREAKER OR FUSES
CONTINUALLY BLOW

1. Undersized breaker or fuses.
(See installation section for ratings.)
2. Wrong voltage supply to steamer.
(A 208 volt steamer supplied with 230 volts will draw approximately 33% excess amperage over the rated nameplate amps).
3. Shorted wiring or connections at terminal block or contactor.
4. Faulty heating element.
5. Carbon buildup across contactor contacts or heating element terminals.

AS A RULE OF THUMB, IF A CIRCUIT BREAKER TRIPS IMMEDIATELY, THERE IS A SHORT CIRCUIT. IF IT STAYS ON A WHILE AND THEN TRIPS, IT IS OVERLOADED OR THE BREAKER OR FUSE IS WEAK.

13. EXCESSIVE PROBLEM WITH
BURNED OFF WIRE CONNECTIONS

1. Factory wire connections are made very carefully. During the life of any machine, wire connections can burn off due to loose connections, or faulty controls.

WHEN A CONNECTION BURNS OFF, BOTH THE WIRE AND THE TERMINAL CONNECTORS SHOULD BE REPLACED. NEW TERMINALS ON BURNED WIRE WILL JUST BURN OFF AGAIN.

TROUBLESHOOTING CHART

COMPLAINTS

POSSIBLE CAUSES

14. WATER CONTINUALLY RUNS OUT OF THE DRAIN LINE
1. Power switch is off for over 5 minutes.
 - a. Fill solenoid leaking through its seat.
 - b. Purge solenoid leaking through its seat.
 - c. Condenser solenoid leaking through its seat.
 - d. Purge timer contacts stuck closed.
 2. Power switch is on & heat switch is off.
 - a. Condenser solenoid is leaking through its seat.
 - b. Drain solenoid is leaking through its seat.
 3. Power switch is on & steam switch is on.
 - a. Normal operation - condenser water is fed into drain line to condense steam, so only condensate exits the drain line.
15. STEAM LEAKS OUT OF COOKING COMPARTMENT DOOR
1. The Steamcraft II is a pressureless free venting steamer. Steam coming out the door almost always indicates a restricted or partially restricted drain line. A condenser solenoid that is not operating can also cause this problem. The cold water in the drain, condensing the steam, causes a natural vacuum which helps draw the steam down the drain.
 2. A broken or badly swollen door gasket.
 3. Food buildup on gasket keeping the gasket from sealing properly.

TROUBLESHOOTING CHART

COMPLAINTS

POSSIBLE CAUSES

- | | |
|--|--|
| 16. TIMER WILL NOT TIME OUT | 1. Faulty timer - replace. |
| 17. TIMER TIMES OUT BUT BUZZER
WILL NOT SOUND | 1. No voltage to buzzer.
a. Timer contacts.
b. Solid State Delay Timer.
2. 120 volts to buzzer.
a. Inoperative buzzer - replace. |
| 18. BUZZER WILL NOT SHUT OFF | 1. Faulty solid state buzzer timer. |