

Patio Heater

Owner's Manual Deluxe Models

FOR YOUR SAFETY:

If you smell gas:

1. Shut off gas to the appliance.
2. Extinguish any open flame.
3. If odor continues, immediately call gas supplier.



FOR YOUR SAFETY:

Do not store or use gasoline or other flammable vapors or liquids in the vicinity of this or any other appliance.

CAUTION: Retain the instructions for future use.

***** Important Notice *****

Do NOT return to place of purchase!

Please contact our Toll Free Hotline for customer service & warranty issues

1-866-985-7877 (1-866-WTL-SUPP)





Well Traveled Living

716 South 8th Street, Amelia Island, FL 32034 USA

Warning: For OUTDOOR USE only



TOOLS AND PARTS NEEDED FOR ASSEMBLY

 <p>DANGER</p>	<p>CARBON MONOXIDE HAZARD</p> <p>This appliance can produce carbon monoxide which has no odor.</p> <p>Using it in an enclosed space can kill you.</p> <p>Never use this appliance in an enclosed space such as a camper, tent, car or home.</p>
	

WARNING: Improper installation, adjustment, alteration, services or maintenance can cause injury, death or property damage. Read the installation, operating and maintenance instructions thoroughly before installing or servicing this equipment.

WARNING

For outdoor use only.

Cylinders to be used must be constructed and marked in accordance with US DOT specifications.

Storage indoors is permissible only if the cylinder is removed.

The unit should be secured or moved indoors if winds exceed 19.5 mph.

Note: 20 lb. LPG Tank is not supplied

TOOLS NEEDED:

- Adjustable Opening Wrench, 8" Long
- Phillips Head Screwdriver
- Leak Detection Solution (Instructions on how to make solution are included in Step 10)

For questions, replacement parts, service help, or other assistance, please call Well Traveled Living's Service Hotline at 1-866-985-7877 (1-866-WTL-SUPP) or email cservice@welltraveled.net.



PARTS

- 1 1 Center Reflector Cap
- 2 3 Reflector Cap
- 3 1 Head Assembly
- 4 1 Gas Hose
- 5 1 Upper Post
- 6 1 Lower Post
- 7 1 Cylinder Cover
- 8 3 Post Mounts
- 9 1 Cylinder Base
- 10 1 Post Support
- 11 3 M8 Screw Cap
- 12 6 M8 Washers
- 13 9 M6 Screw Cap
- 14 9 M6X8 Bolts
- 15 4 M5X10 Bolts
- 16 4 M6X10 Bolts
- 17 6 M6X18 Bolts
- 18 6 M6 Screw Cap
- 19 1 Regulator
- 20 3 M8X90 Double Pointed Bolts
- 21 3 M8X16 Bolts

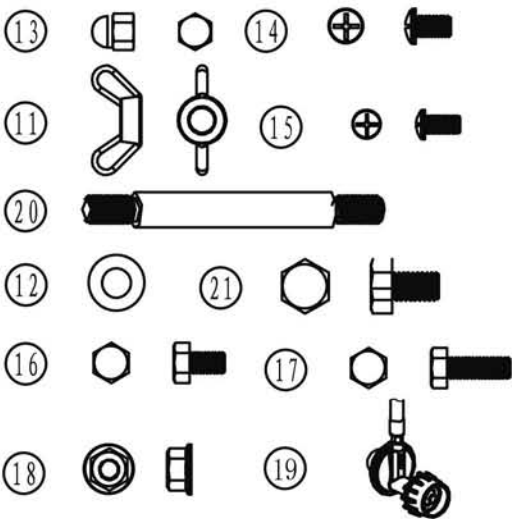



PRECAUTIONS

NOTE: PLEASE READ THE FOLLOWING SAFETY RULES

WARNING:

This appliance must only be used outdoors. Using this product in an enclosed area may cause injury, death or property damage.

Read the instructions before use.

This appliance must be installed in accordance with such regulations as are in force.

Do not use the heater in an explosive atmosphere. Keep the heater away from areas where gasoline or other flammable liquids or vapors are stored.

Prior to use, check for damaged parts such as hoses, regulators, pilot or burner.

Warning : This appliance requires a gas hose and regulator.

Regularly check the gas hose and if necessary, replace the gas hose.

DISCONNECT LPG bottle before moving the heater.

Do not attempt to alter unit in any manner.

EXAMPLE: using the heater without the top canopy reflector or radiant screen.

Do not shorten the burner post assembly.

The appliance shall not be used in basements or below ground level.

It must always be placed on a solid and level surface.

Always ensure there is ample fresh air ventilation.

For outdoor use ONLY.

Maintain at least 24" side clearance and 36" top clearance to combustible materials & surfaces.

Never replace or substitute the regulator with any regulator other than the factory suggested replacement.

Do not clean the heater with cleaners that are combustible or corrosive.

Do not paint radiant screen, control panel or top canopy reflector.

All leak tests should be done with a soapy solution. **NEVER USE AN OPEN FLAME TO CHECK FOR LEAKS.**

The LP gas cylinder should be turned off when the heater is not in use.

At least once a year, the unit should be inspected for the presence of spiders, spider webs or other insects. Check the heater immediately if any of the following exist:

1. The smell of gas in conjunction with extreme yellow colored tips of the burner flames.
2. The heater does not reach temperature.
3. The burner makes popping noises during use (a slight popping noises is normal when the burner is extinguished after using).

The propane hose with regulator assembly shall be located out of pathways where people may trip over it or in areas where the hose will not be subject to accidental damage.

Children and adults should be aware of the hazards of high surface temperature and shall stay away to avoid clothing burn or ignition.

Young children should be carefully supervised when they are in the area of the heater.

Clothing or other flammable material should not be hung from the heater, or placed on or near the heater.

Any guard or other protective device removed for servicing the heater must be replaced prior to operating the heater.

Installation and repair should be done by a qualified service person. The heater should be inspected before use and cleaning may be required at least once a year, or as necessary. It is imperative that control compartment, burner and circulating air passageways of the heater be kept clean.

Keep the appliance area clear of combustible materials such as gasoline and other flammable vapors and liquids.

Do not obstruct the flow of combustion and ventilation air.

Keep the ventilation opening of the cylinder enclosure free and clear of debris.

Save these instructions! Retain in a safe place for future reference.

Well Traveled



Warning:

Proper assembly is the responsibility of the installer.

Step 1 --- Attach post mounts to cylinder base

Place the post mounts on the top of cylinder base, and connect them using 3pcs M8 X 16 bolts.

Step 1

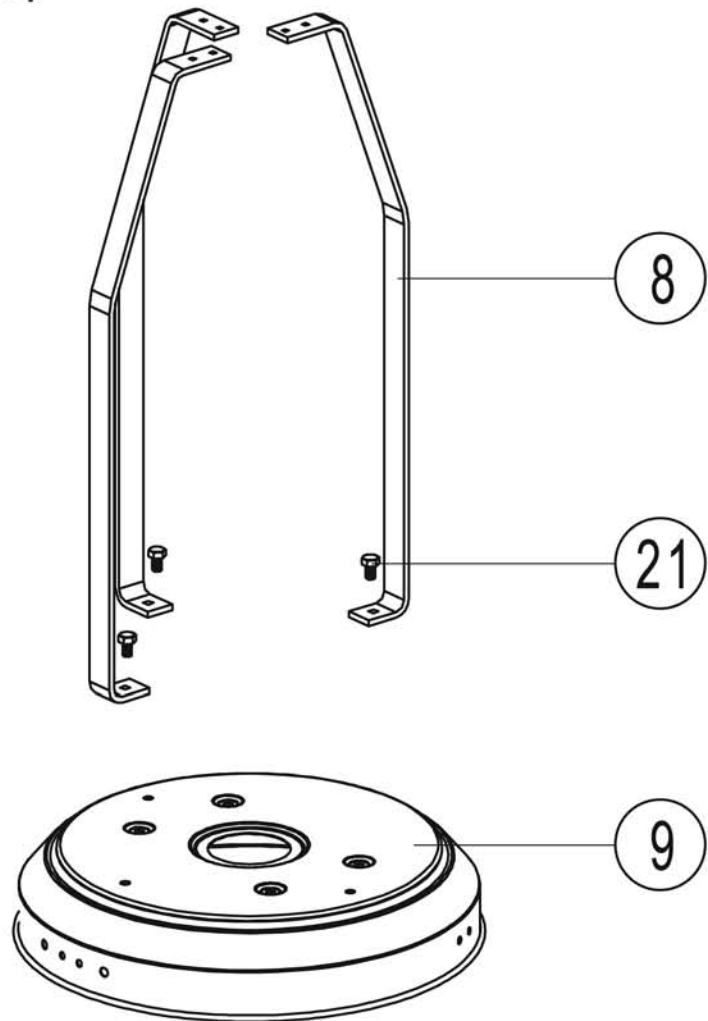



ASSEMBLY

Step 2---- Attach post support to post mounts

Place the post support on the top of post mounts using 6pcs M6 X 18 screw bolts, 6pcs M6 screw caps.

Step 2

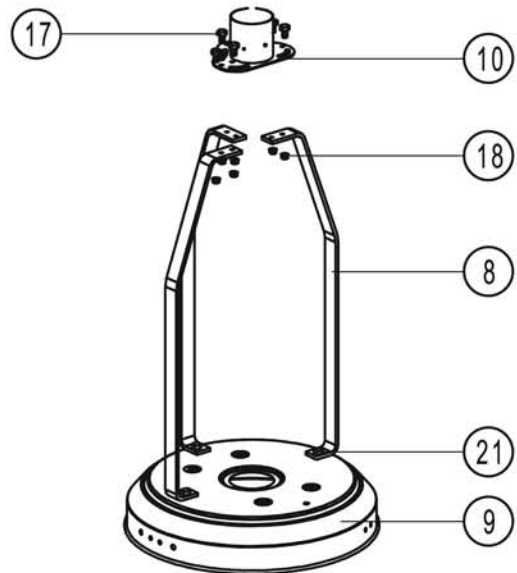

Step 3 ---- Attach lower post to base assembly

Attach the lower post to the post mounts using 4pcs M6 X 10 bolts.

Step 3

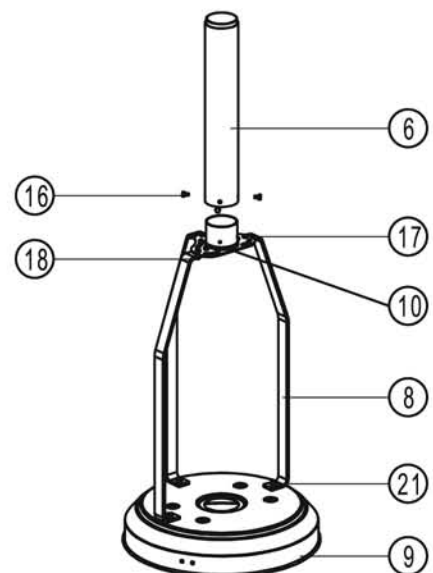

Well Traveled



ASSEMBLY

Step 4 --- Attach upper post to lower post

Screw the upper post to the lower post as illustrated by turning in a clockwise direction until securely tightened.

Step 4

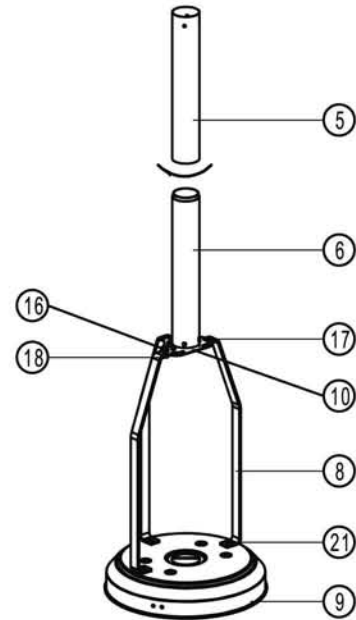

Step 5 --- Attach cylinder cover to post mounts

Attach cylinder cover to the post mounts.

Step 5

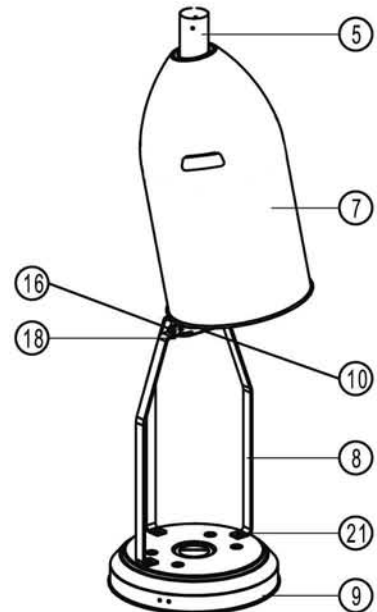

Well Traveled



ASSEMBLY

Step 6 ---- Attach double pointed bolts to head assembly

Attach M8 X 90 double pointed bolts (3pcs) to head assembly

Step 6

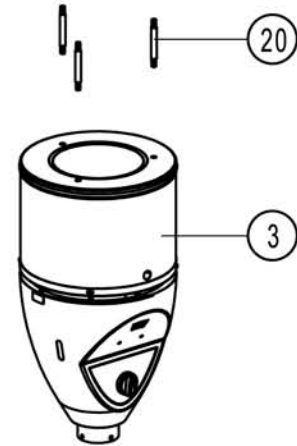

Step 7---- Attach the gas hose to head assembly

Route the gas hose up through the post and out of top, then connect to the head assembly by turning in a clockwise direction.

Finally Connect the the head assembly with post with 4pcs M5 X 10 bolts.

Step 7

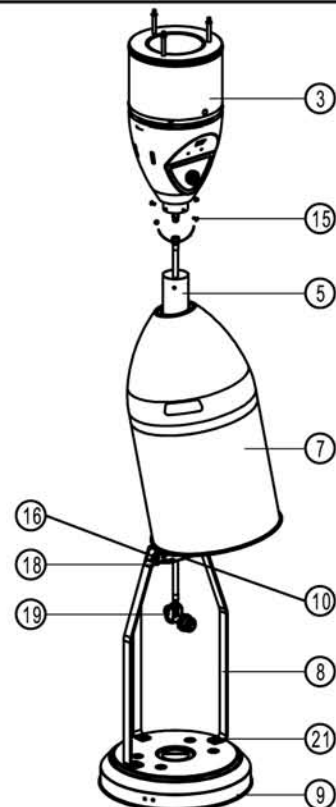

Well Traveled



Step 8 ---- Attach the reflector to the top of head assembly

Place 3pcs M8 washers on the top of 3pcs double pointed bolts. Place assembled reflector on top of double pointed bolts. Place remaining 3pcs of M8 washers on top of ends of double pointed bolts secure with 3pcs M8 wing nuts.

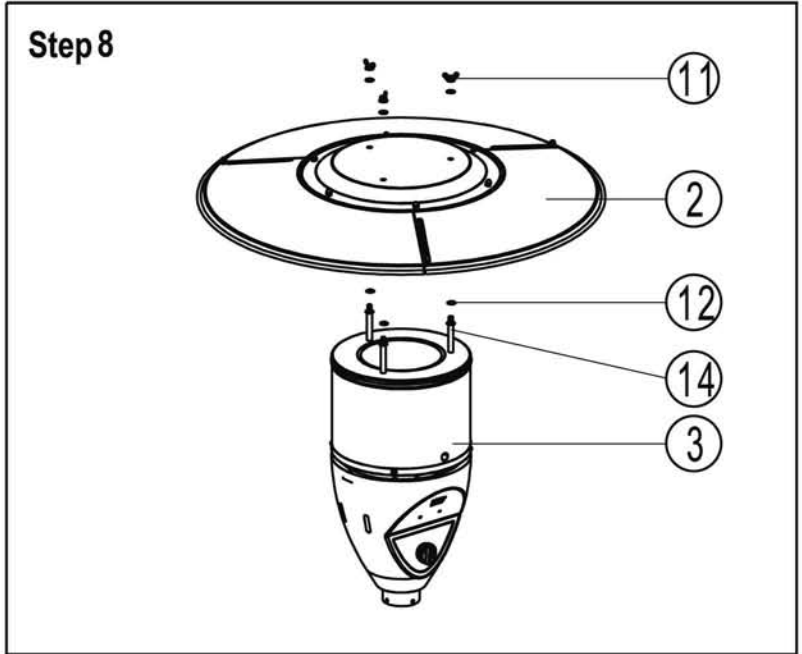

**Step 9 ---- Connect Gas Hose to Cylinder (Not supplied)**

Attach Gas hose to regulator with
3/8 Inch Open End Wrench and
Adjustable Wrench.

Attach regulator to cylinder. Tighten securely.
Move cylinder to the plate of base assembly.

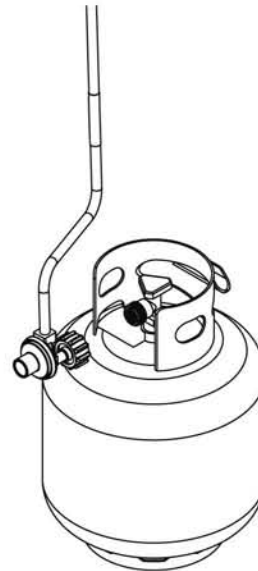
Step 9**Step 10 ---- Check for Leak**

Your Patio Heater has been checked at the factory
for all possible connection leaks. To check the
connection of the gas hose/regulator/cylinder.

- 1) Make leak solution by mixing 1 part liquid dish soap and 3 parts water.
- 2) Spoon several drops (or use squirt bottle) of the solution onto the gas hose/regulator and regulator/cylinder connection.
- 3) Inspect the connections and look for bubbles.
- 4) If no bubbles appear, the connection is safe.
- 5) If bubbles appear, there is a leak. Loosen and re-tighten this connection.
- 6) If leak continues call a qualified service person.
- 7) Use of teflon (plumber's) tape on threads of gas connections is recommended.

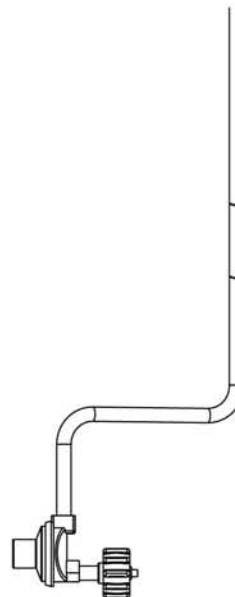
Step 10



ASSEMBLY

Step 11 ---- Lower Cylinder Cover onto Cylinder Base

Lower the cylinder cover onto the cylinder base .

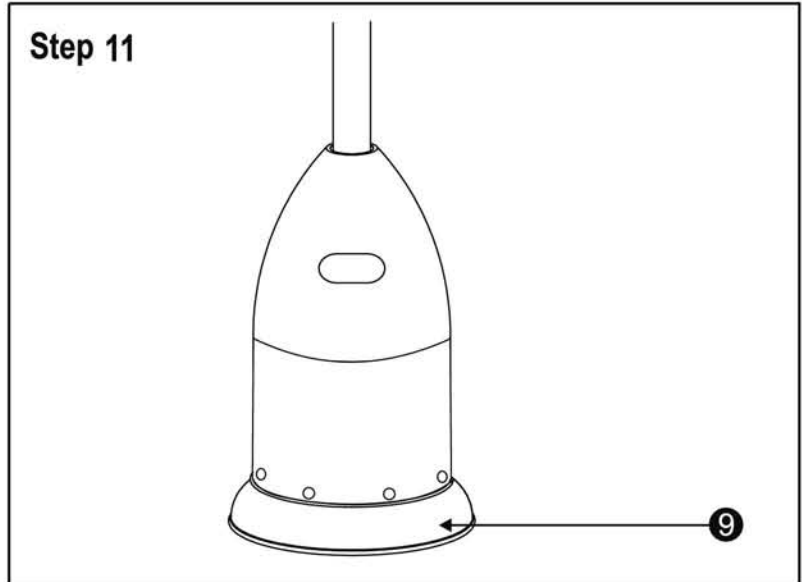

Step 12 ---- Disconnect Cylinder When Storing or Transporting

- 1). Turn off the heater.
- 2). Turn off the valve of the cylinder.
- 3). Lift the cylinder cover above the post mounts.
- 4). Loosen the screw of cylinder and regulator.
- 5). Disconnect the cylinder from regulator.

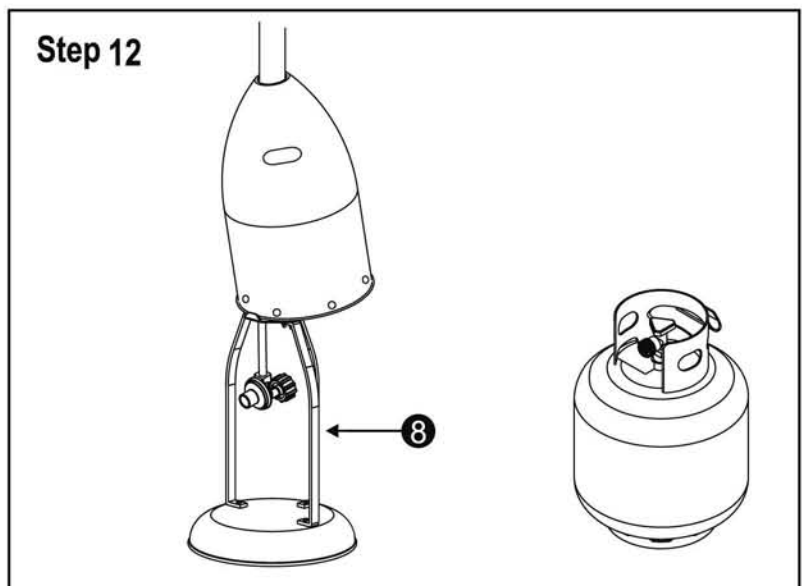

Well Traveled



The installation must conform with local codes or, in the absence of local codes, with the most current version of the National Fuel Gas Code, ANSI Z223.1

OPERATION

WARNING: Do NOT attempt to operate heater until you have read and understood all precautions.

Failure to do so can result in serious personal injury, death and/or property damage.

Before Turning Gas Supply ON

Your heater was designed and approved for OUTDOOR USE ONLY. Do NOT use it inside a building, or any other enclosed area.

Make sure surrounding areas are free of combustible materials, gasoline and other flammable vapors or liquids.

Ensure that there is no obstruction to air ventilation.

Be sure all gas connections are tight and there are no leaks.

Be sure the access panel is clear of debris.

Be sure any component removed during assembly or servicing is replaced and fastened prior to starting.

Before Lighting

Heater should be thoroughly inspected before each use, and by a qualified service person at least annually.

If relighting a hot heater, always wait at least 5 minutes.

Our heater is tested for quality assurance.

Ignition attempts should succeed 8 out of 10 attempts.

LIGHTING INSTRUCTIONS

- 1) Turn the control knob to "OFF" position.
- 2) Fully open gas valve
- 3) Push in gas control knob and turn counterclockwise to "IGNITE" then to "PILOT" position, this will light the pilot.
If needed, keep depressing and turning control knob counterclockwise until the pilot lights. (You will hear 2 clicking noises)
- 4) Once the pilot is lit, continue to keep the control knob depressed for at least 30 seconds, After 30 seconds release control knob.
- 5) If pilot does not stay lit, repeat steps 3 and 4.
- 6) If pilot still does not stay lit, then:
 - a) Push in gas control knob and turn counterclockwise to "IGNITE" then to "PILOT"
 - b) Keep depressing the control knob. Put long stem lighter into the Ignition Hole on the emitter screen to light the pilot.
 - c) Repeat step 4.
- 7) Push in and turn control knob counterclockwise to "LOW" position, release knob then turn to low. If you want a higher temperature, push in the control knob and turn counterclockwise to the "HIGH" position.

Note: The flame pattern at the emitter grid should be **visually checked** whenever heater is operated. Normally the burner flame is blue, but a little yellow flame is acceptable.

If flames extend beyond the emitter grid or there are black spots that have accumulated on the emitter grid or reflector, immediately turn off the patio heater. The heater should not be operated again until it has been serviced and repaired by a qualified gas technician.

If you experience any ignition problem, turn off the heater and gas supply, and consult "Troubleshooting" on page 17.

WARNING

FOR YOUR SAFETY:

If at any time you are unable to light burner and smell gas, wait 5 minutes to allow gas to dissipate before attempting to light heater. If, after 1 minute, you are unable to light burner, wait 5 minutes and allow flammable vapors to dissipate before attempting to light heater again.

WARNING

FOR YOUR SAFETY:

Do NOT touch or move heater for at least 45 minutes after use. Allow emitter and dome to cool before touching.

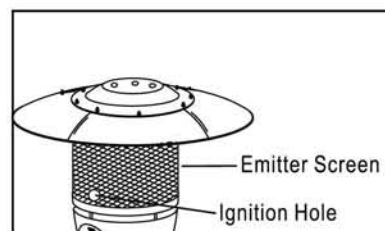
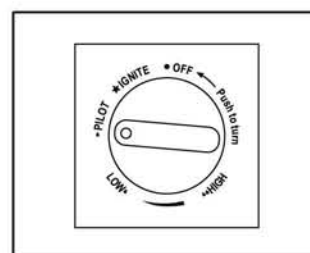
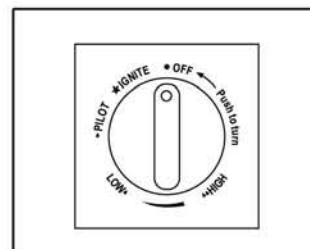



OPERATION

CAUTION : Avoid inhaling fumes emitted from the heater's first use. Smoke and odor from the burning of oils used in manufacturing will appear. Both smoke and odor will dissipate after approximately 30 minutes. The heater should NOT produce thick black smoke.

NOTE:

The burner may be noisy when initially turned on. To eliminate excessive noise from the burner, turn the Control Knob to the "LOW" position. Then, turn the knob to the level of heat desired.

When heater is ON:

Emitter screen will become bright red due to intense heat. The color is more visible at night. Burner will display tongues of blue flame. These flames should not be yellow or produce thick black smoke, indicating an obstruction of airflow through the burners.

Operation Pressure Checked

If the flame is very small, this is because the supply pressure is not enough.

To Light

- 1) Turn the control knob to "OFF" position.
- 2) Wait five (5) minutes before attempting to relight pilot.
- 3) Repeat steps beginning with step 2 on page 12.

Before Leaving

- 1) Turn the control knob to "OFF" position and Turn LP cylinder to "OFF" position.
- 2) Never leave the patio heater unattended while in use.

SHUT DOWN INSTRUCTIONS

- 1) Push in and turn control knob clockwise to "OFF" position.
- 2) Turn L.P. tank gas valve clockwise to "OFF" position when heater is not in use

Note: After use, some discoloration of the emitter screen is normal.

The Event of Gas Leakage

- 1) Turn the control knob to "OFF" position.
- 2) Turn LP cylinder to "OFF" position.
- 3) Wait 5 minutes to allow gas to dissipate.
- 4) If odor continues, immediately call gas supplier.

WARNING : Heater will be hot after use.
Handle with extreme care.

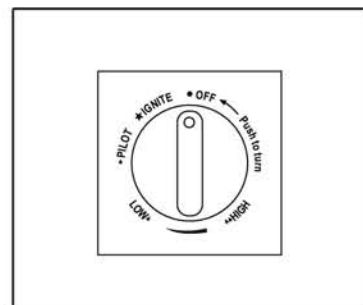
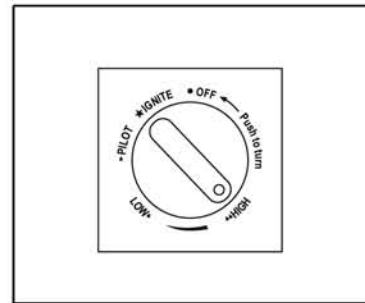



LOCATING HEADER FOR USE

BE CAREFUL: WHEN CERTAIN MATERIALS OR ITEMS ARE LEFT, ABOVE, BESIDE OR UNDER THIS HEATER WHILE IN USE, THEY WILL BE SUBJECT TO RADIANT HEAT AND COULD BE SERIOUSLY DAMAGED.

This heater is primarily used for the heating of outdoor patios, decks, spas, pool and open working areas.

Always make sure that adequate fresh air ventilation is provided. Follow the spacing tolerances shown in Figure 1.

The minimum clearances, shown in Figure 1, must be maintained at all times.

The installation must conform to local codes, or in the absence of local codes, with the standard for the storage and handling of liquid petroleum gases, ANSI/NFPA 58-1986, or most recent addition. For Canada, with the current CAN1-B149.

This heater must be placed on level, firm ground.

Never operate in an explosive atmosphere. Keep away from areas where gasoline or other flammable liquids or vapors are stored or used.

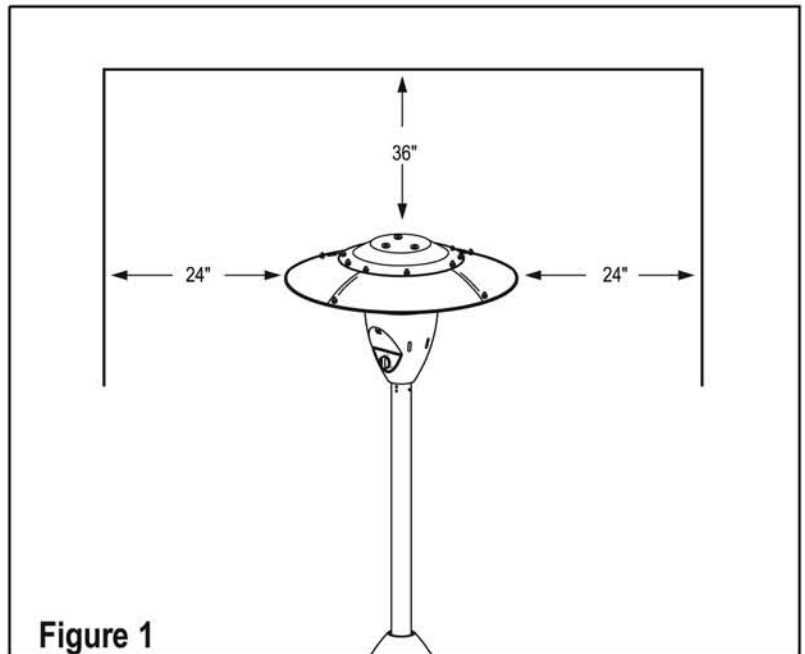



MAINTENANCE/STORAGE

Check Your Hose Assembly:

The installation of fixed appliances shall only be carried out by competent persons and be in accordance with the relevant Codes of Practice.

Warning: This appliance requires a gas hose and regulator, check with your gas supplier and or product supplier. **Regularly check** the gas hose and if necessary, replace the gas hose.

Prior to use, check for damaged parts such as hoses, regulators, pilot or burner.

Never replace or substitute the regulator with any regulator other than the factory suggested replacement.

Check Your Flame:

The flame pattern at the **Emitter Screen** should be **Visually Checked** whenever heater is operated.

Normally the burner flame is blue, but little yellow flame is acceptable.

If flames extend beyond the emitter grid or there are black spots that have accumulated on the emitter grid or reflector, immediately turn off the patio heater. The heater should not be operated again until it has been serviced and repaired by a qualified gas technician.

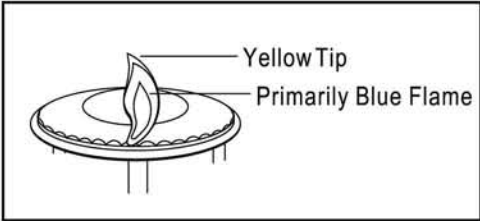
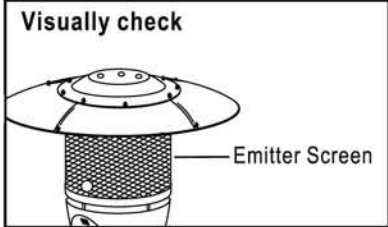

WARNING
FOR YOUR SAFETY :
DO NOT touch or move heater for at least 45 minutes after use.
Allow all burner elements to cool before touching.

NOTE
In a salt-air environment (such as near an ocean) corrosion occurs more quickly than normal. Frequently check for corroded areas and repair them promptly.

Clean:

To enjoy years of outstanding performance from your heater make sure you perform the following maintenance activities on a regular basis:

- Keep exterior surfaces clean.
 - Use warm soapy water for cleaning. Never use flammable or corrosive cleaning agents.
 - While washing your unit, be sure to keep the area around the burner and pilot assembly dry at all times. If the gas control is exposed to water in any way, do NOT try to use it. It must be replaced.
- Air flow must be unobstructed. Keep controls, burner, and circulating air passageways clean. Signs of possible blockage include:
 - Gas odor with extreme yellow tipping of flame.
 - Heater does NOT reach the desired temperature.
 - Heater glow is excessively uneven.
 - Heater makes popping noises.
- Spiders and insects can nest in burner or orifices. This dangerous condition can damage heater and render it unsafe for use. Clean burner holes by using a heavy-duty pipe cleaner. Compressed air may help clear away smaller particles.
- Carbon deposits may create a fire hazard. Clean dome and emitter screen with warm soapy water if any carbon deposits develop.



STORAGE :

Between uses:

- Turn the control knob to "OFF" position.
- Turn LP cylinder to "OFF" position.
- Store heater upright in an area sheltered from direct contact with inclement weather (such as rain, sleet, hail, snow, dust and debris).
- If desired, cover heater to protect exterior surfaces and to help prevent debris in air passages.

During periods of extended inactivity or when transporting;

- Turn the control knob to "OFF" position.
- Disconnect LP Cylinder and move to a secure, well-ventilated location outdoors. **Do NOT** store in a location that will exceed 125 degrees F.
- The propane cylinder must be stored outdoors in well-ventilated area, and it must be out of reach of children, and not in a building, garage or any other enclosed area.
- Store heater upright in an area sheltered from direct contact with inclement weather (such as rain, sleet, hail, snow, dust and debris). If desired, cover heater to protect exterior surfaces and to help prevent debris in air passages.

NOTE

Wait until heater is cool before covering.



TROUBLESHOOTING

PROBLEM	PROBABLE CAUSE	SOLUTION
Pilot will not light	Gas valve may be OFF	Turn the gas valve ON
	Fuel Tank empty	Refill LP gas tank
	Orifice blocked	Clean or replace orifice
	Air in supply system	Purge air from lines
	Loose connection	Check all fittings
Pilot will not stay on	Debris around pilot	Clean dirty area
	Loose connection	Tighten connection
	Thermocouple bad	Replace thermocouple
	Gas leak in line	Check connections
	Lack of fuel pressure	Fuel tank is near empty
Burner will not light	Pressure is low	Fuel tank is near empty
	Orifice blocked	Remove, clean and replace
	Control valve not ON	Turn valve to ON
	Thermocouple bad	Replace thermocouple
	Pilot light assembly bent or not in correct location	Place pilot in proper position and retry

Distributed By:
Well Traveled Living
716 S 8th Street
Amelia Island, FL 32034
Toll Free: 866-WTL-SUPP



Web: www.wtliving.com
Email: cservice@welltraveled.net

1 YEAR LIMITED WARRANTY – Customers in the Continental US

All components are warranted for a period of 1 year after date of purchase by the original owner against defects in materials and workmanship under normal use. This warranty does NOT cover normal wear and weathering, assembly and/or maintenance OR use in a commercial application. At Well Traveled Living's sole discretion, products under warranty will be repaired and/or replaced at no charge to the customer. Any returns sent back to Well Traveled Living must be sent via prepaid freight and in the original retail packaging.

For warranty service contact Well Traveled Living at the address, phone numbers or internet site and email listed in this owner's manual. Be sure to have your sales receipt, date of purchase and catalogue/model numbers available when calling. All warranty service will be coordinated by the Well Traveled Living's, Amelia Island, Florida service center.

This warranty is extended only to the original purchaser. Proof of purchase will be required before warranty service is rendered. The sales receipt is the only valid proof of purchase. This warranty only covers failures due to defects in materials or workmanship which occur during normal use. Failures and/or damage which result from accident, negligence, misuse, abuse, neglect, mishandling, alteration or modification, failure to maintain, improper assembly or maintenance, service by unauthorized agency or use of unauthorized components or damage that is attributable to acts of God are NOT covered.

*****THERE ARE NO EXPRESS WARRANTIES EXCEPT AS LISTED ABOVE*****

*****PURCHASER ASSUMES ALL RISKS IN THE ASSEMBLY AND OPERATION OF THIS UNIT*****

*****FAILURE TO FOLLOW WARNINGS AND OPERATIONAL INSTRUCTIONS CONTAINED IN THIS MANUAL CAN RESULT IN SEVERE PROPERTY DAMAGE AND/OR PERSONAL INJURY*****

IN NO EVENT WILL WELL TRAVELED LIVING, OR ITS DIRECTORS, OFFICERS OR AGENTS BE LIABLE TO THE PURCHASER OR ANY THIRD PARTY, WHETHER IN CONTRACT, IN TORT, OR ON ANY OTHER BASIS, FOR ANY INDIRECT, SPECIAL, PUNITIVE, EXEMPLARY, CONSEQUENTIAL, OR INCIDENTAL LOSS, COST, OR DAMAGE ARISING OUT OF OR IN CONNECTION WITH THE SALE, MAINTENANCE, USE, OR INABILITY TO USE THE PRODUCT, EVEN IF WELL TRAVELED LIVING OR ITS DIRECTORS, OFFICERS OR AGENTS HAVE BEEN ADVISED OF THE POSSIBILITY OF SUCH LOSSES, COSTS OR DAMAGES, OR IF SUCH LOSSES, COSTS, OR DAMAGES ARE FORESEEABLE. IN NO EVENT WILL WELL TRAVELED LIVING, OR ITS OFFICERS, DIRECTORS, OR AGENTS BE LIABLE FOR ANY DIRECT LOSSES, COSTS OR DAMAGES THAT EXCEED THE PURCHASE PRICE OF THE PRODUCT.

SOME JURISDICTIONS DO NOT ALLOW THE EXCLUSION OR LIMITATION OF INCIDENTAL OR CONSEQUENTIAL DAMAGES, SO THE ABOVE LIMITATION OR EXCLUSION MAY NOT APPLY TO THE PURCHASER.

This limited warranty gives you specific legal rights and you may also have other rights which vary from jurisdiction to jurisdiction. The provisions of the United Nations Convention on Contracts for the Sales of Goods shall not apply to this limited warranty or the sale of products covered by this limited warranty.

*****IMPORTANT NOTICE*****

-Do **NOT** return to place of purchase-
For customer service and warranty issues
contact our Customer Service Center at:

(866)-985-7877 OR

Email: cservice@welltraveled.net

Customer Service Hours: Mon. – Fri. 9:00 a.m. – 6:00 p.m. (EST)