

**Experts In Home Cleaning™**

# STEAMmop™

## USER'S GUIDE

90T1 SERIES 220-240V

- 2 Thank You
- 3 Safety Instructions
- 4- Product View
- 5 Assembly
- 6 Special Features
- 6-8 Operations
- 9 Maintenance and Care
- 10 Troubleshooting
- 10 Replacement Parts
- 10 Additional Accessories
- 11 Warranty
- 12 Consumer Services



## Thanks for buying a BISSELL Steam Mop™

We're glad you purchased a BISSELL Steam Mop. Everything we know about floor care went into the design and construction of this complete, high-tech home cleaning system.

Your BISSELL Steam Mop is well made, and we back it with a limited one year warranty. We also stand behind it with a knowledgeable, dedicated Consumer Services department, so, should you ever have a problem, you'll receive fast, considerate assistance.

My great-grandfather invented the floor sweeper in 1876. Today, BISSELL is a global leader in the design, manufacture, and service of high quality homecare products like your BISSELL Steam Mop

Thanks again, from all of us at BISSELL.

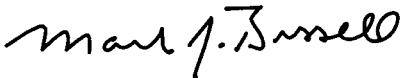

**Mark J. Bissell**  
Chairman, President & CEO

# IMPORTANT SAFETY INSTRUCTIONS

When using an electrical appliance, basic precautions should be observed, including the following:

## READ ALL INSTRUCTIONS BEFORE USING STEAM MOP.

Always connect to a properly Earthed outlet. Unplug from outlet when not in use and before conducting maintenance or troubleshooting.

### **WARNING:** To reduce the risk of fire, electric shock, or injury:



- Use indoors only
- Do not immerse
- Use only on surfaces moistened by cleaning process
- Do not leave machine when it is plugged in
- Do not service machine when it is plugged in
- If the supply cord is damaged, it must be replaced by the manufacturer or its service agent in order to avoid a hazard
- Do not use machine if it has been dropped, damaged, left outdoors or dropped into water
- Do not expose to rain, store indoors
- Do not pull or carry by cord, use cord as a handle, close door on cord, pull cord around sharp corners or edges, run appliance over cord, or expose cord to heated surfaces
- Do not carry the appliance while in use
- Do not unplug by pulling on cord; unplug by grasping plug not the cord
- Do not handle plug or appliance with wet hands
- Do not put any object into appliance openings, use with blocked opening or restrict air flow
- Do not expose hair, loose clothing, fingers or body parts to openings or moving parts
- Do not pick up hot or burning objects
- Do not pick up flammable or combustible materials (lighter fluid, petrol, kerosene, etc.) or use in the presence of explosive liquids or vapours
- Do not use appliance in an enclosed space filled with vapours given off by oil base paint, paint thinner, some moth proofing substances, flammable dust, or other explosive or toxic vapours
- Remove plug from electrical outlet before cleaning or maintaining the appliance

- Not intended for use by persons (including children) with reduced physical, sensory or mental capabilities, or lack of experience and knowledge, unless they have been given supervision or instruction concerning use of the appliance by a person responsible for their safety
- Young children should be supervised to ensure that they do not play with the appliance
- Do not pick up toxic material (chlorine bleach, ammonia, drain cleaner, petrol, etc.)
- Do not modify the Earthed plug
- Do not allow to be used as a toy
- Do not use for any purpose other than described in this User's Guide
- Use only manufacturer's recommended attachments
- Use only cleaning products formulated by BISSELL for use in this appliance to prevent internal component damage
- Keep openings free of dust, lint, hair, etc.
- Keep appliance on a level surface
- Turn off all controls before unplugging
- Be extra careful when cleaning stairs
- Liquid or steam must not be directed towards equipment containing electrical components
- Pay close attention when working around children

## SAVE THESE INSTRUCTIONS.

THIS MODEL IS FOR HOUSEHOLD USE ONLY.

 **WARNING:** This appliance must be Earthed.

 The symbol  means WARNING: Danger of scalding.

 Surface may be hot. Avoid contact.

**IMPORTANT** FOR OPERATION ON A 220-240 VOLT A.C. 50/60 Hz POWER SUPPLY ONLY.

If your appliance is fitted with a nonrewireable BS 1363 plug it must not be used unless a 13 amp (ASTA approved to BS 1362) fuse is fitted in the carrier contained in the plug. Spares may be obtained from your BISSELL supplier. If for any reason the plug is cut off, it must be disposed of, as it is an electric shock hazard should it be inserted into a 13 amp socket.

# Product view

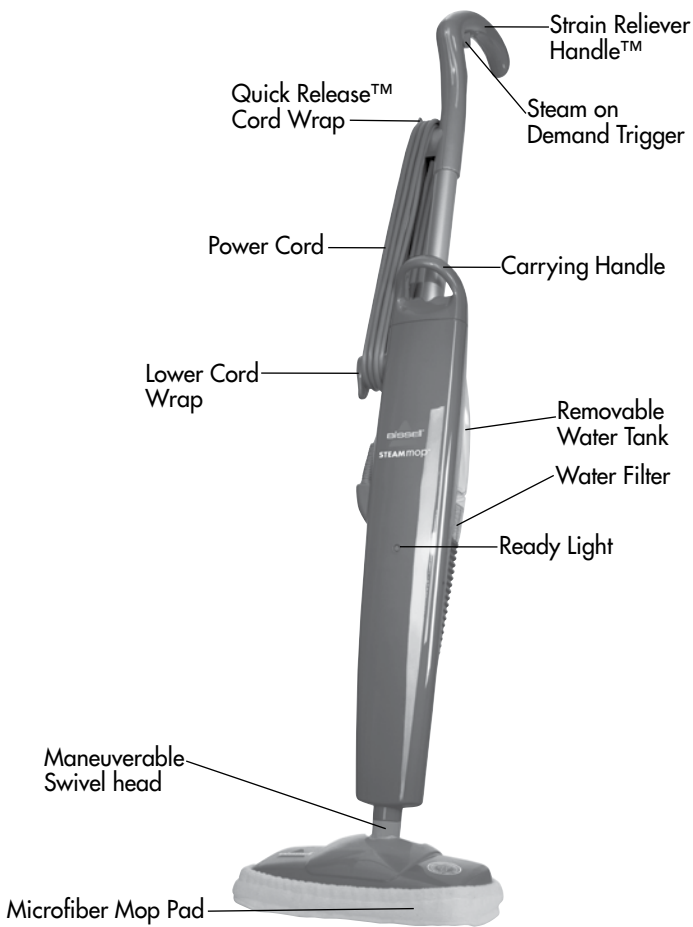

# Assembly

**Your Steam Mop assembles quickly and easily. The only thing you will need for assembly is a Phillips head screwdriver.**

**Your Steam Mop is packaged with the following items:**

**Handle Assembly**

**Lower Body with Water Filter**

**Maneuverable Swivel Head**

**Removable Water Tank**

**1 large Phillips Head Screw taped to the handle**

**1 small Phillips Head Screw taped to the handle**

**2 Microfiber Mop Pads**

1. Attach lower body to maneuverable swivel head.
2. Secure maneuverable swivel head with small Phillips head screw. Tighten until secure.
3. Slide handle assembly down into lower body until it will go no further.
4. Secure the handle by placing the large Phillips head screw through the screw opening in the lower body and into the rear of the handle assembly. Tighten with screwdriver until secure.
5. Slide water tank onto lower body by lining up vertical glides and gently sliding tank into place.

Steam Mop assembly is now complete.

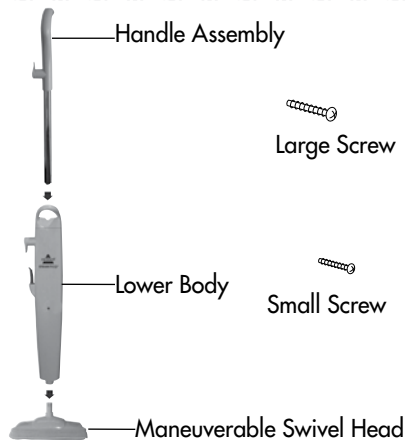

## Special features

### Removable water tank

The water tank is located on the back of the Steam Mop. It can be refilled with water any time during use. Distilled or demineralized water may be used in place of tap water.

Do not use chemicals with your Steam Mop.

### Water filter

This filter removes minerals and other impurities from tap water, preventing water deposits from damaging your Steam Mop. It should be replaced when the bright green grains turn blue. To maximize performance of the filter, distilled water may be used.

*Tip:*

Do not attempt to use your Steam Mop Max without water in the tank.

### Ready light

The ready light will glow when the Steam Mop is ready to use.

### Steam on demand trigger

Press to release steam.

### Maneuverable swivel head

When cleaning in the manual mode, press the spray trigger to release water and formula onto the area to be cleaned.

### Microfiber mop pads

Reuseable microfiber mop pad is machine washable and safe for all hard floor surfaces.

## Operations

### Getting ready

**The mop pad may have already come attached to the swivel head, if not follow steps 1A and 1B below.**

1. Attach mop pad
  - A. Set swivel head in mop pad, making sure the drawstring is located on the back
  - B. Tighten mop pad by pulling on the drawstring while pressing on the toggle.

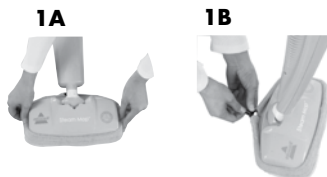

# Operations

## Getting ready continued

2. Fill the water tank by lifting straight up and away from unit. Unscrew cap at bottom of water tank and remove the insert assembly.
3. Fill water tank with water. For best results, water should be at room temperature. Replace insert assembly and cap, tighten until snug.
4. Replace water tank by lining up vertical guides and gently sliding tank into place.
5. Twist the Quick Release cord wrap clockwise to unwrap the power cord and plug into a proper grounded outlet as described on page 3.
6. The ready light will illuminate when Steam Mop is ready for use.

## Before you clean

**Thoroughly sweep or vacuum floor prior to cleaning with the Steam Mop.**

## Cleaning hard floors

**Steam Mop is designed to clean hard floor surfaces like ceramic tile, vinyl, laminate, marble, stone and sealed hard wood floors. Use of Steam Mop on waxed or unwaxed floors may result in a diminished glossiness. Steam Mop is not for use on unsealed wood floors. Ensure Steam Mop is thoroughly tested in an inconspicuous area prior to mopping a large floor area. Also, be sure to check the care instructions from your flooring manufacturer.**

1. Begin cleaning by slowly passing over the surface while pressing the steam on demand trigger to emit steam as needed.

**NOTE: The trigger does not need to be depressed at all times for Steam Mop to work satisfactorily.**

2. To sanitize an area of your floor, (attack invisible germs and bacteria) put the center of Steam Mop over the spot for a minimum of 15 seconds using continuous steam, but no longer than 20 seconds. For larger areas, overlap swivel head placement.

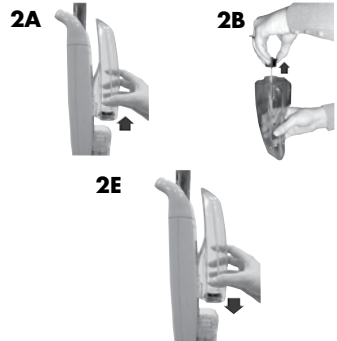

## **⚠️ WARNING:**

Never put descaling, aromatic, alcoholic, or detergent products into the steam cleaner, as this may damage it or make it unsafe for use.

## **⚠️ CAUTION:**

Exercise extreme care when using the Steam Mop on timber flooring. Ensure the Steam mop is thoroughly tested in an inconspicuous area prior to mopping a large floor area. The Steam Mop generates hot steam, so when depressing the trigger to apply steam, ensure the Steam Mop is moving continuously. The trigger does not need to be depressed at all times. Prolonged application of steam in one area increases the risk of damage to the surface treatment on timber floors. Check with your timber floor treatment application specialist prior to Steam Mop operation. Regular foot traffic and direct sunlight will wear down timber floor surface treatment making it more susceptible to steam damage. Exercise extreme care when using the Steam Mop on timber flooring.

## Cleaning hard floors continued

**Important:** Sanitizing on timber floors is not recommended as prolonged application of steam in one area increases the risk of damage to the surface treatment on timber floors, especially in areas with regular foot traffic and direct sunlight, which will wear down timber floor surface treatments making it more susceptible to steam damage. See CAUTION on page 7.

3. When the Steam Mop stops emitting steam, turn the unit off and unplug it. Simply remove the water tank, refill, plug back in, and continue cleaning.

## Carpet Refresher Attachment (select models)

This accessory is recommended for the refreshing of carpets. Once the Steam Mop is cradled in the carpet refresher attachment, it will easily glide over the carpet.

**NOTE:** Always be sure a mop pad is in place before placing in carpet refresher attachment. Only white mop pads should be used with the carpet attachment. Do not use carpet attachment on spots or stains, or glide it over the same spot for longer than 20 seconds.

1. Attach the mop pad to the swivel mop head. As directed in step 1 on page 6.
2. Place the swivel mop head, with mop pad attached, in the carpet refresher attachment.  
**Note: The Steam Mop rests in the carpet refresher attachment and may not stay attached to the swivel mop head. It is meant to glide over the carpet.**
3. Fill the water tank with water. Begin refreshing your carpet or rug by pushing the Steam Mop in a forward and backward motion, releasing steam as you go.
4. When you have finished refreshing your carpet or rug, unplug the steam mop and remove from the carpet or rug.

**NOTE:** Move the Steam Mop and carpet refresher attachment in a continuous motion until you are finished. This product is not intended to be used as a carpet cleaner, only a carpet refresher or deodorizer. Never attempt to use the Steam Mop on carpet without the carpet refresher attachment in place. DO NOT leave the mop in a stationary position.

## NOTE:

Upon first use of the Steam Mop or first use of a new water filter, the pump may make a "KNOCKING" sound while the water filter fills with water. This is normal and will last between 30 seconds to a minute. Continue to depress the trigger until the "KNOCKING" subsides and the unit begins emitting steam.





# Maintenance and care

## When you're done

1. Unplug power cord from outlet.
2. Carefully remove mop pad from swivel head, as mop pad and lower assembly will be hot.
3. Any water remaining in the water tank should be emptied prior to machine storage.
4. Mop pad can be machine washed in warm water. Use only liquid detergents. Do not use bleach or fabric softeners. For best results, air dry.
5. Wrap power cord around Quick Release cord wrap on side of Steam Mop.
6. Wipe all surfaces of Steam Mop with a soft cloth. Store upright in a protected, dry area.

**IMPORTANT:** Do not perform the maintenance in the note below until the unit has had time to cool.

**NOTE:** If steam output is reduced, the nozzle may be blocked. To remedy, unplug unit, remove swivel head from lower body and pour vinegar through center tube of swivel head "neck". Clear nozzle by inserting a paper clip into the brass spray tip located in bottom of lower body.

## Replacing the water filter

If you fill your Steam Mop cleaner with normal tap water, it is essential to check the water filter and replace it when it is no longer effective. Change the water filter when the bright green grains turn blue. If the water filter is not changed at the appropriate time, calcium deposits will accumulate on the heating element, causing damage or reduced performance.

Using distilled or demineralized water will maximize the performance of your water filter.

To order a replacement water filter refer to the replacement parts section on page 10.



## **CAUTION:**

Upright storage of the Steam Mop with a wet mop pad may result in the formation of white marks on your floor. To remove the white marks, clean area with vinegar.

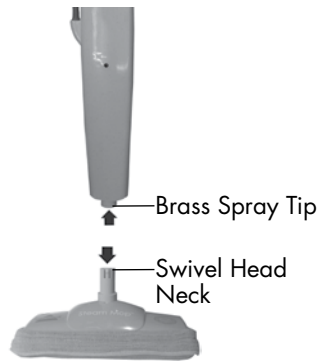

### *Tip:*

Using distilled or demineralized water will maximize the performance of your water filter.

### *Tip:*

Be sure to use only a BISSELL water filter in Steam Mop

# Troubleshooting

## Reduced steam or no steam.

### Possible Causes

1. Water tank empty
2. Depleted water filter
3. Blocked steam nozzle

### Remedies

1. Fill tank
2. Replace water filter
3. Refer to NOTE on page 9

**Other maintenance or service not included in the manual should be performed by an authorized service representative.**

**Thank you for selecting a BISSELL product.**

**Please do not return this product to the store.**

## Replacement parts

| Item | Part No. | Part Name                      |
|------|----------|--------------------------------|
| 1    | 20P5     | Water Filter                   |
| 2    | 203-2167 | Handle Assembly with Screw     |
| 3    | 203-2159 | Water Tank with Cap and Insert |
| 4    | 603-2046 | Cap and Insert Assembly        |
| 5    | 203-2168 | Storage Hook with Screws       |

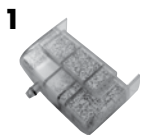

## Additional Accessories

**These items are available for purchase as accessories for your BISSELL Steam Mop:**  
**To purchase call 1-800-237-7691 or visit [www.bissell.com](http://www.bissell.com).**

| Item | Part No. | Part Name                                   |
|------|----------|---|
| 1    | 98T1     | Carpet Refresher Attachment with 2 Mop Pads |
| 2    | 3252-E   | Eucalyptus and Mint Natural Aroma           |
| 3    | 53M4     | Microfiber Mop Pads - 2 pack                |
| 4    | 90M7-E   | 946 mL Eucalyptus and Mint Scented Water    |



# Warranty BISSELL Steam Mop™

This warranty gives you specific legal rights, and you may also have other rights which may vary from country to country. If you need additional instruction regarding this warranty or have questions regarding what it may cover, please contact BISSELL Consumer Services by E-mail, telephone, regular mail as described below, or contact your local in country distributor.

## Limited One Year Warranty

Subject to the \*EXCEPTIONS AND EXCLUSIONS identified below, BISSELL Homecare, Inc. will repair or replace (with new or remanufactured components or products), at BISSELL's option, free of charge from the date of purchase by the original purchaser, for one year any defective or malfunctioning part due to manufacturer defect.

See "BISSELL Consumer Services" information below.

This warranty applies to product used for personal, and not commercial or rental service. This warranty does not apply to fans or routine maintenance components such as filters. Damage or malfunction caused by negligence, abuse, neglect, unauthorized repair, or any other use not in accordance with the User's Guide is not covered.

## BISSELL Consumer Service:

If your BISSELL product should require service or if you need information about repairs, authorized service centers in your area, replacement parts or your warranty, please contact BISSELL Consumer Services, as indicated below, or contact your local in country distributor.

### For UK inquiries:

Monday - Thursday 9 am — 5 pm  
Friday 9 am — 4 pm

### BISSELL Homecare (Overseas) Inc.

Ground Floor  
226 Berwick Avenue  
Slough  
Berkshire, SL1 4QT  
United Kingdom  
Telephone: 0844-888-6644

### For South African inquiries:

Monday - Friday 9 am — 5 pm

### Tevo (PTY) Ltd.

P.O.Box 25234  
Gateway 4321, South Africa  
Telephone: 27 (0) 86-177-8888  
email: servicecentre@tevo.co.za

### For Middle East & Africa inquiries:

Sunday - Thursday 8 am — 5 pm

### BISSELL Middle East & Africa

PO Box 61286  
Jebel Ali Free Zone  
Dubai  
United Arab Emirates  
Telephone: 971-4-881-8597

### For all other inquiries:

Monday - Friday 8 am — 4 pm

### BISSELL Homecare, Inc.

PO Box 1888  
Grand Rapids, Michigan 49501 USA  
Telephone: 01-616-453-4451  
Fax: 01-616-453-1383

BISSELL HOME CARE, INC. IS NOT LIABLE FOR INCIDENTAL OR CONSEQUENTIAL DAMAGES OF ANY NATURE ASSOCIATED WITH THE USE OF THIS PRODUCT. BISSELL'S LIABILITY WILL NOT EXCEED THE PURCHASE PRICE OF THE PRODUCT.

### \*EXCEPTIONS AND EXCLUSIONS FROM THE TERMS OF THE LIMITED WARRANTY

THIS WARRANTY IS EXCLUSIVE AND IN LIEU OF ANY OTHER WARRANTIES EITHER ORAL OR WRITTEN. ANY IMPLIED WARRANTIES WHICH MAY ARISE BY OPERATION OF LAW, INCLUDING THE IMPLIED WARRANTIES OF MERCHANTABILITY AND FITNESS FOR A PARTICULAR PURPOSE, ARE LIMITED TO THE ONE YEAR DURATION FROM THE DATE OF PURCHASE AS DESCRIBED ABOVE.

# BISSELL consumer services

## If your BISSELL product should require service:

Call BISSELL Consumer Services at the numbers below and we will give you the location of a BISSELL Authorized Service Center in your area. If you have questions about your warranty or need replacement parts please contact the numbers below. Or visit the BISSELL website - [www.bissell.com](http://www.bissell.com)

### For UK inquiries:

Monday - Thursday 9 am — 5 pm  
Friday 9 am — 4 pm

### BISSELL Homecare (Overseas) Inc.

Ground Floor  
226 Berwick Avenue  
Slough  
Berkshire, SL1 4QT  
United Kingdom  
Telephone: 0844-888-6644

### For South African inquiries:

Monday - Friday 9 am — 5 pm

### Tevo (PTY) Ltd.

P.O.Box 25234  
Gateway 4321, South Africa  
Telephone: 27 (0) 86-177-8888  
email: [servicecentre@tvo.co.za](mailto:servicecentre@tvo.co.za)

### For Middle East & Africa inquiries:

Sunday - Thursday 8 am — 5 pm

### BISSELL Middle East & Africa

PO Box 61286  
Jebel Ali Free Zone  
Dubai  
United Arab Emirates  
Telephone: 971-4-881-8597

### For all other inquiries:

Monday - Friday 8 am — 4 pm

### BISSELL Homecare, Inc.

PO Box 1888  
Grand Rapids, Michigan 49501 USA  
Telephone: 01-616-453-4451  
Fax: 01-616-453-1383

When contacting BISSELL, have model number of cleaner available.

Please record your Model Number: \_\_\_\_\_

Please record your Purchase Date: \_\_\_\_\_

**NOTE: Please keep your original sales receipt. It provides proof of purchase date in the event of a warranty claim. See Warranty on page 11 for details.**



©2011 BISSELL Homecare, Inc.  
Grand Rapids, Michigan  
All rights reserved. Printed in China  
Part Number 120-4381  
Rev 5/11  
Visit our website at:  
[www.bissell.com](http://www.bissell.com)

