



INSTALLATION MANUAL FOR TDC & THDC MODELS (TRUE DIPPING CABINET MODELS)



TDC-47



THDC-6

TABLE OF CONTENTS

- ▶ **Safety Information**
 - Safety Precautions** _____ 1
 - Proper Disposal** _____ 2
 - Connecting Electricity** _____ 3
 - Use of Adapter Plugs & Extension Cords** _____ 3
- ▶ **Installation / Operation Instructions**
 - Ownership** _____ 4
 - Required Tools** _____ 4
 - Uncrating & Locating** _____ 4
 - Sealing Cabinet to Floor** _____ 5
 - Ventilation** _____ 5
 - Cabinet Drain** _____ 5
 - Installation of Optional Legs/Castors** _____ 6
 - Optional Dipper Well Installation for TDC Models** 7
 - Instructions for Optional Lid Lock for TDC Models** 8
 - Electrical Instructions** _____ 9
 - Start-up** _____ 9
 - Storage / Loading Product** _____ 10
 - Temperature Control / Defrost Operations** _____ 11
- ▶ **Maintenance, Care & Cleaning**
 - Cleaning Condenser Coil** _____ 12
 - Cleaning the Cabinet** _____ 13
 - Stainless Steel Equipment Care & Cleaning** – 14-15
 - Changing Light Bulb on TDC Models** _____ 15
 - Warranty (U.S.A & CANADA ONLY!)** _____ 16

CONGRATULATIONS!

You have just purchased the finest commercial freezer available. You can expect many years of trouble-free operation.

* Dutch version included.

TRUE DIPPING CABINETS & HORIZONTAL DIPPING CABINETS

NOTICE TO CUSTOMER:



**Loss Or Spoilage Of Products
In Your Refrigerator/Freezer
Is NOT Covered By Warranty.
In Addition To Following
Recommended Installation
Procedures You Must Run
The Refrigerator/Freezer
24 Hours Prior To Usage.**

True Manufacturing Company, Inc.

SAFETY INFORMATION

How to Maintain Your *TRUE*® Unit to Receive the Most Efficient and Successful Operation

You have selected one of the finest commercial freezer units made. It is manufactured under strict quality controls with only the best quality materials available. Your TRUE freezer, when properly maintained, will give you many years of trouble-free service.

WARNING!

Use this appliance for its intended purpose as described in this Owner Manual.

SAFETY PRECAUTIONS

When using electrical appliances, basic safety precautions should be followed, including the following:

- This freezer must be properly installed and located in accordance with the Installation Instructions before it is used.
- Do not allow children to climb, stand or hang on the shelves in the freezer. They could damage the freezer and seriously injure themselves.
- Do not touch the cold surfaces in the refrigerated compartment when hands are damp or wet. Skin may stick to these extremely cold surfaces.
- Do not store or use flammable liquids or vapors in the vicinity of this or any other appliance.
- Keep fingers out of the “pinch point” areas; clearances between the doors and cabinet are necessarily small; be careful closing doors when children are in the area.

NOTE: Any servicing, warranty repairs or maintenance should be carried out by qualified personnel, failure to do so could be dangerous and may invalidate your warranty.

- Unplug the freezer before cleaning and making repairs.
- Setting temperature controls to 0 position does not isolate the unit from the electrical supply, you must disconnect the main power lead from the wall receptacle to isolate.

SAFETY INFORMATION

DANGER!
RISK OF CHILD ENTRAPMENT

HOW TO SAFELY DISPOSE OF USED FREEZER EQUIPMENT

Child entrapment and suffocation are not problems of the past. Junked or abandoned display cases are still dangerous... even if they will sit for “just a few days.”

It is much safer if doors and lids are removed so children cannot get trapped inside, leaving the shelves in place will also deter children from trying to climb inside.

If you are getting rid of your old display case, please follow the instructions below to help prevent accidents. Depending on the country where the unit is located there will be officially approved ways of disposing of your used equipment.

It is important that care is taken in disposing of used freezers. Before You Throw Away Your Old Freezer:

- Take off the doors.
- Leave the shelves in place so that children may not easily climb inside.

Refrigerant Disposal

Your old freezer may have a cooling system that uses “Ozone Depleting ” chemicals. If you are throwing away your old refrigerator, make sure the refrigerant is removed for proper disposal by a qualified service technician. If you intentionally release any refrigerants you can be subject to fines and imprisonment under provisions of the environmental regulations.

SAFETY INFORMATION

WARNING!

HOW TO CONNECT ELECTRICITY

Do not, under any circumstances, cut or remove the third (ground) prong from the power cord. For personal safety, this appliance must be properly grounded.

The power cord of this appliance is equipped with a 3-prong (grounding) plug which mates with a standard 3-prong (grounding) wall outlet to minimize the possibility of electric shock hazard from this appliance.

Have the wall outlet and circuit checked by a qualified electrician to make sure the outlet is properly grounded.

If the outlet is a standard 2-prong outlet, it is your personal responsibility and obligation to have it replaced with the properly grounded 3-prong wall outlet.

The freezer should always be plugged into it's own individual electrical circuit, which has a voltage rating that matches the rating plate.

This provides the best performance and also prevents overloading building wiring circuits which could cause a fire hazard from overheated wires.

Never unplug your freezer by pulling on the power cord. Always grip plug firmly and pull straight out from the outlet.

Repair or replace immediately all power cords that have become frayed or otherwise damaged. Do not use a cord that shows cracks or abrasion damage along its length or at either end.

When removing the freezer away from the wall, be careful not to roll over or damage the power cord.

USE OF ADAPTER PLUGS

NEVER USE AN ADAPTER PLUG! TRUE will not warranty any freezer that has been connected to an adapter plug.

North America Use Only!

NEMA plugs
TRUE uses these types of plugs.
If you do not have the right outlet
have a certified electrician install
the correct power source.



USE OF EXTENSION CORDS

NEVER USE AN EXTENSION CORD! TRUE will not warranty any freezer that has been connected to an extension cord.

INSTALLATION / OPERATION INSTRUCTIONS

INSTALLATION / OPERATION INSTRUCTIONS

OWNERSHIP

To insure that your unit works properly from the first day, it must be installed properly. We highly recommend that your True unit is installed by your supplying dealer or service company. The cost of a professional installation is money well spent. Issues caused by incorrect installation may invalidate your warranty

Before you start to install your True unit, carefully inspect it for freight damage. If damage is discovered, immediately file a claim with the delivery freight carrier or supplying dealer.

True is not responsible for damage incurred during shipment.

REQUIRED TOOLS

- Adjustable Wrench
- Phillips Head Screwdriver
- Level

UNCRATING

The following procedure is recommended for uncrating the unit:

- Remove the outer packaging by pulling tri-wall nails from skid. Remove (4) cardboard corner pads and dust cover.
- Inspect for concealed damage. Again, immediately file a claim with the freight carrier if there is damage.
- Move your unit as close to the final location as possible before removing the wooden skid.

LOCATING

- Remove packing material from cabinet.
- Remove skid by unscrewing all base brackets shown in photo 1 and illustration 1 & 2.
- Carefully remove unit from shipping skid and place the skid to the side.

Removing base brackets that anchor the unit to the shipping skid.



Photo 1.

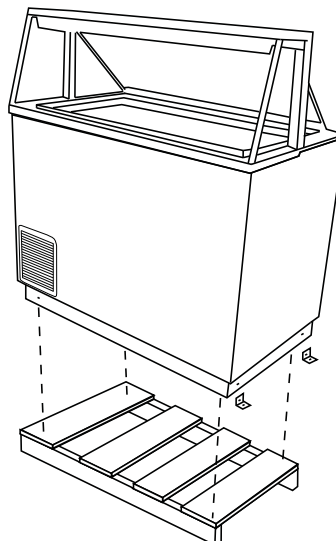

Illustration 1.

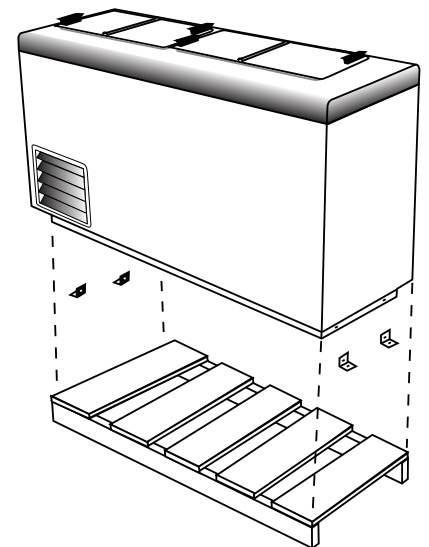

Illustration 2.

INSTALLATION / OPERATION INSTRUCTIONS

SEALING CABINET TO FLOOR

Step A - Position Cabinet

When positioning cabinet into a final location make sure there are no obstructions in front of the intake and exhaust areas. These areas are located in the front and back of the cabinet.

Step B - Level Cabinet

Cabinet should be level, side to side and front to back. Place a carpenter's level in the interior floor in four places:

1. Position level in the inside floor of the unit near the front. (Level should be parallel to cabinet front). Level cabinet.
2. Position level at the inside rear of cabinet. (Again level should be placed parallel to cabinet back).
3. Perform similar procedures to steps 1 & 2 by placing the level on inside floor (left and right sides - parallel to the depth of the cooler). Level cabinet.

Step C

Draw an outline on the base on the floor.

Step D

Raise and block the front side of the cabinet.

Step E

Apply a bead of "NSF Approved Sealant", (see list below), To floor half inch inside the outline drawn. The bead must be heavy enough to seal the entire cabinet surface when it is down on the sealant.

Step F

Raise and block the rear of the cabinet

Step G

Apply sealant on floor as outline in Step E. on other three sides.

Step H

Examine to see that cabinet is sealed to floor around entire perimeter.

Note:

Asphalt floors are very susceptible to chemical attack. A layer of tape on the floor prior to applying the sealant will protect the floor.

NSF Approved Sealants:

1. Minnesota Mining #ECU800 Caulk
2. Minnesota Mining #ECU2185 Caulk
3. Minnesota Mining #ECU1055 Bead
4. Minnesota Mining #ECU1202 Bead
5. Armstrong Cork - Rubber Caulk
6. Products Research Co. #5000 Rubber Caulk
7. G.E. Silicone Sealer
8. Dow Corning Silicone Sealer

VENTILATION

A. Set unit in its final location. Be sure there is adequate ventilation in your room. Maximum ambient operating temperature is 75° F / 55% humidity.

Warning

Warranty is void if ventilation is insufficient.

CABINET DRAIN

A. True Dipping Cabinets have a drain at the bottom of the unit. (See image 1). The drain hose is located behind the rear grill of the unit. (See image 2). Back out four 1/4" hex head screws to remove the rear grill when accessing this drain hose. When cleaning the unit make sure the drain hose is connected to a garden type hose that is routed to a floor drain.

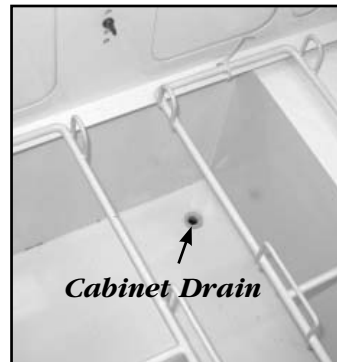

Image 1



Image 2

INSTALLATION / OPERATION INSTRUCTIONS

INSTALLATION OF OPTIONAL LEGS AND CASTORS

Removing Kickplate:

Before installing optional legs or castors the kickplate at the bottom of the unit will need to be removed. To remove kickplate first remove any loose items from inside the unit (shelving, baskets, etc). Then remove the top plastic lid which you gain access to the inside of the unit. Lay the unit on it's side. Make sure the unit is on soft packing material so not to scratch the cabinet. Then backout 1/4" hex head screws all around the base of the unit. (See illustration 1 and image 1). After the kickplate has been removed reinstall all of the hex head screws back into the base of the unit. (See image 2). castors and legs are to be installed in the corners of the base of the unit.

Unit Leveling With Castors:

Four leveling shims have been provided for leveling on uneven floors when using optional castors. Shims must be positioned between the base of the unit and bearing race. True recommends a four shim limit to any single castor.

- A.** Turn the bearing race counter-clockwise until the cabinet is level. Level front to back and side to side. (diagonally)
- B.** Install the desired number of shims, making sure the slot of the shim is in contact with the threaded stem of the castor.
- C.** If more than one shim is used, turn the slot at a 90° angle so they are not in line.
- D.** Turn the bearing race clockwise to tighten and secure the castor by tightening the anchoring bolt with a 3/4 inch open-end wrench, socket, or the tool provided.

CAUTION

To avoid damage to lower rail assembly, slowly raise unit to upright position after installing castors.

Unit Leveling With Legs:

Turn the legs clockwise to tighten in each corner of the cabinet base. (See image 4). After legs are secure level the unit by backing out the end the leg shown in image 5. Turn the end of the leg until the cabinet is level. Level front to back and side to side (diagonally).

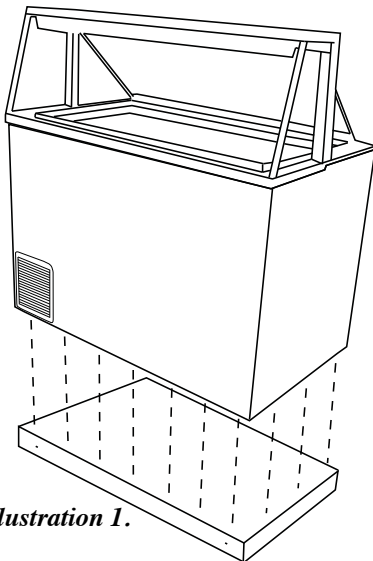

Illustration 1.

Standard Kickplate

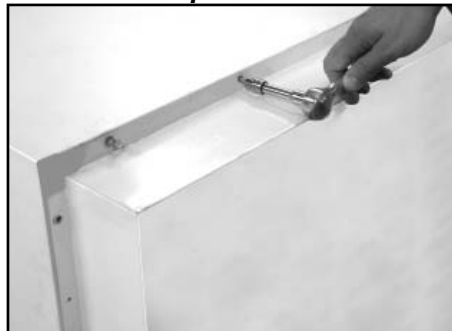

Image 1 (Removing kickplate).

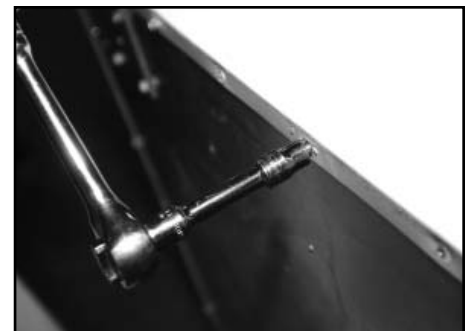

Image 2 (Reinstalling screws from kickplate).

Optional Castors and Legs



Image 3 (Installing castors).



Image 4 (Installing legs).



Image 5 (Leveling legs).

INSTALLATION / OPERATION INSTRUCTIONS

OPTIONAL DIPWELL FOR TDC MODELS

(Installing Dipwell):

True Dipping Cabinets come standard with pre-installed riv-nut holes to attach an optional dipwell. There are multiple riv-nut holes for dipwell locations on the cabinet. Locate which area you want the dipwell installed then proceed with the directions below. (See image 1).

- A.** Remove the dipwell backplate from one of two boxes that contain the dipper well assembly.
- B.** Two Phillips pan head machine screws are provided in the kit to mount the backplate to the cabinet with the Inlet Tube Clip and Inlet Tube. (See image 2 and illustration 1).
- C.** After attaching the dipwell bowl to the backplate connect the drain tube to the bowl and run it to a floor drain.
- D.** Assemble the Plastic Tube to the Barrel Valve and then onto the Inlet Tube. (See illustration 1).
- E.** Have a plumber tap the Saddle Valve Assembly into the copper water line.

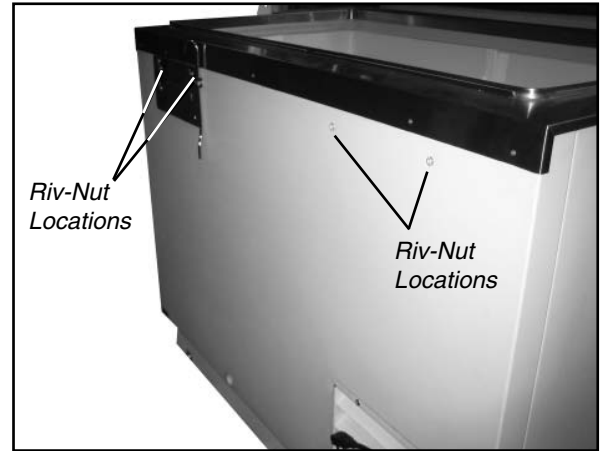

Image 1 (Riv-nut locations).

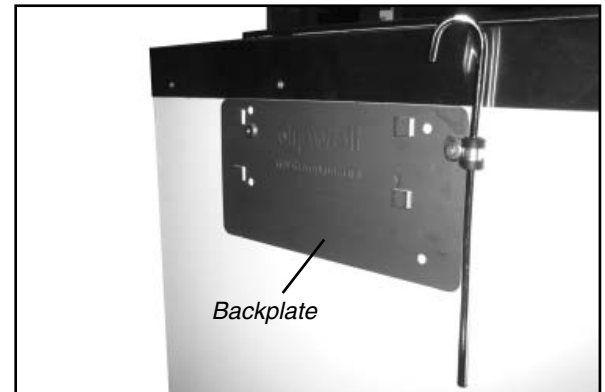
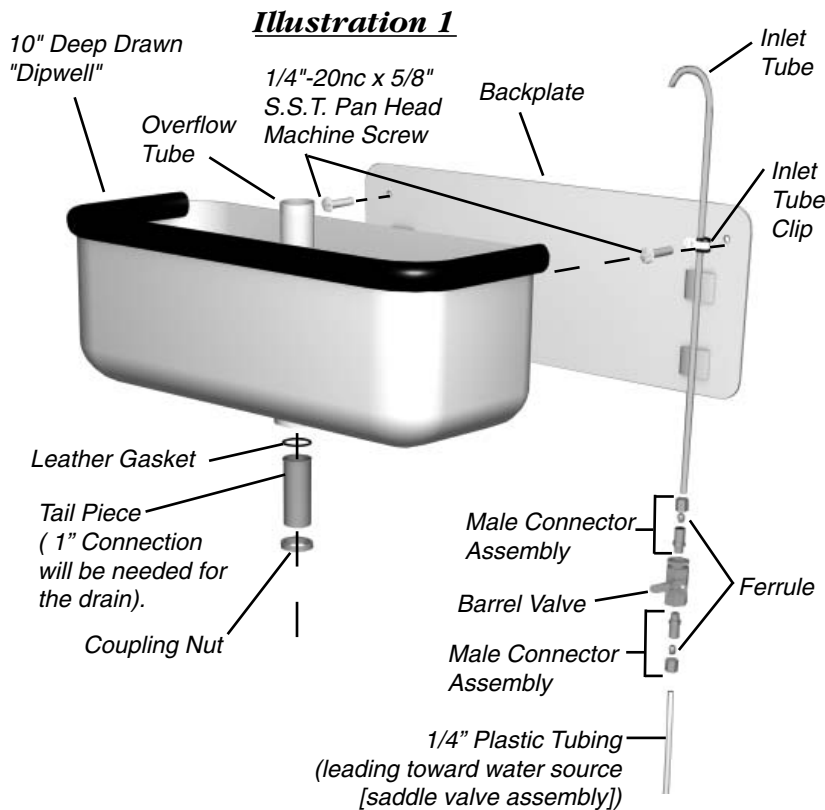

Image 2 (Dipwell Backplate installation).



Image 3 (Dipwell bowl installation).



Saddle Valve Assembly

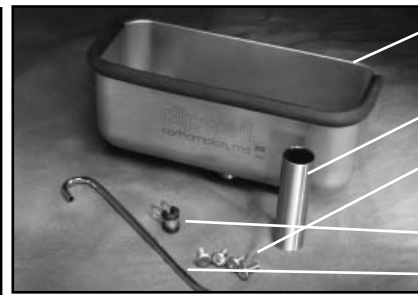
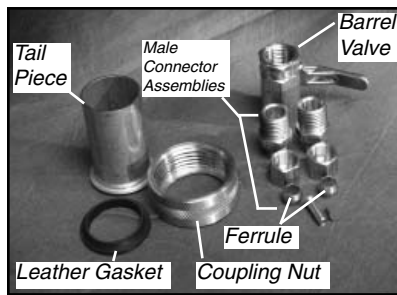

10" Deep Drawn "Dipwell"
Overflow Tube
S.S.T. Pan Head Machine Screws
Inlet Tube Clip
Inlet Tube

INSTALLATION / OPERATION INSTRUCTIONS

INSTALLATION INSTRUCTIONS FOR OPTIONAL LID LOCK KIT FOR TDC MODELS ONLY.

REQUIRED TOOLS

- Drill
- 5/16" inch drill bit
- Padlock



Image 1 (TDC Lock Bracket)

STEP 1

Slide lock bracket under stainless steel trim near center of lid. (See image 1). Mark the hole location of the lock bracket on the Dipping cabinet handle.

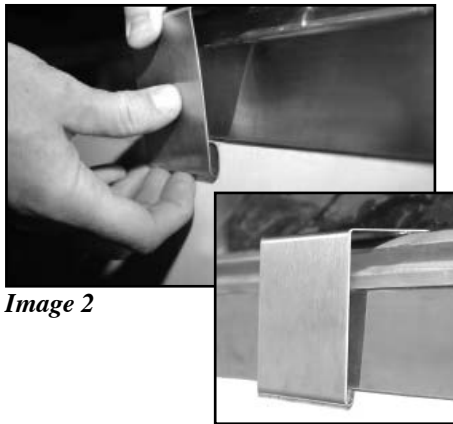

Image 2

STEP 2

Remove the lock bracket after marking the hole location. Then drill 5/16" diameter hole centered on back of the Dipping cabinet aluminum handle. (See image 3 & illustrations below).



Image 3 (Drilling lock bracket hole)

STEP 3

Reinstall the lock bracket. Slip the hooked end of the lock bracket under the stainless steel top (See image 4). Pull out and up to allow the lock bracket to pass over the aluminum handle. Place a padlock through the lock bracket and handle. (See image 5).

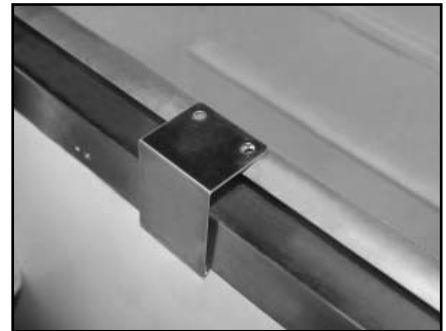
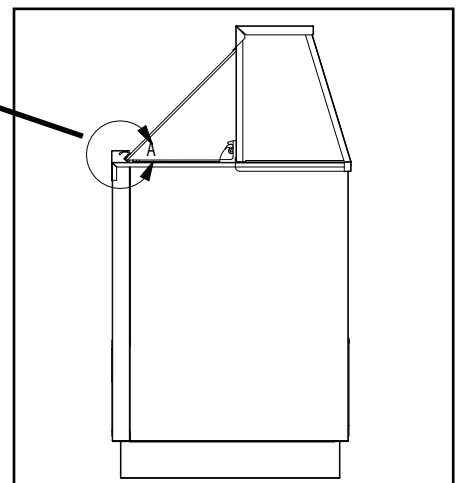
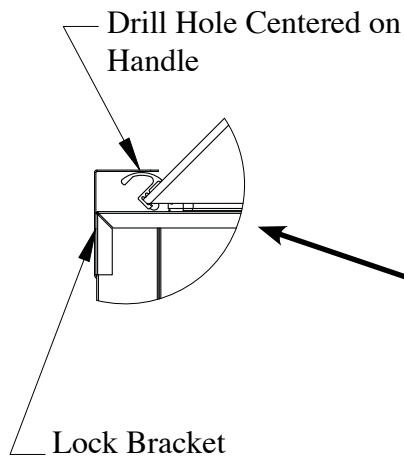
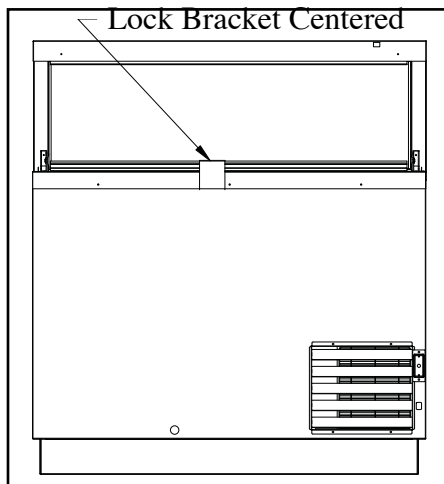

Image 4



Image 5



INSTALLATION / OPERATION INSTRUCTIONS

ELECTRICAL INSTRUCTIONS

- A.** Before your new unit is connected to a power supply, check the incoming voltage with a voltmeter. If anything less than 100% of the rated voltage for operation is noted, correct immediately.
 - B.** All units are equipped with a 7 ft. (2.1m) service cord, and must be powered at proper operating voltage at all times. Refer to cabinet data plate for this voltage.
- True** requires that a sole circuit be dedicated for the unit. Failure to do so voids warranty.

WARNING
Compressor warranties are void if compressor burns out due to low voltage.

WARNING
Power supply cord ground should not be removed!

NOTE
To reference wiring diagram - Remove lower rear grill. Wiring diagram is positioned on the inside cabinet wall.

STARTUP

- A.** The compressor is ready to operate. Plug in the unit.
- B.** The temperature control is set at the No. 4 position from the factory. Allow unit to function several hours, completely cooling cabinet before changing the control setting.
- C.** Excessive tampering with the control could lead to service difficulties. Should it ever become necessary to replace temperature control, be sure it is ordered from your True dealer or recommended service agent.

NOTE
If the unit is disconnected or shut off, wait five minutes before starting again.

RECOMMENDATION
Before loading product we recommend you run your True unit empty for two to three days. This allows you to be sure electrical wiring and installation are correct and no shipping damage has occurred. Remember, our factory warranty does not cover product loss!

REPLACEMENT PARTS
TRUE maintains a record of the cabinet serial number for your unit. If at any time during the life of your display case, a part is needed, you may obtain this part by furnishing the model number and serial number to the company from whom you purchased the cabinet. Call Toll-Free: (800)-424-TRUE (Direct to Parts Department). (800)-325-6152 (U.S.A. & Canada only) or call: (636)-240-2400.

Serial Number

True CABINET SERIAL NUMBER: **1-9123456**

Manufacturing Co. O'FALLON, MO 63366 #9123456*

MODEL: TMW DESIGN PRESSURES-PSIG HIGH SIDE 488 LOW SIDE 174 REFRIG UNIT: AJA7494ZXD CHARGE REFRIGERANT: R404A 45 OZ.

HP	VOLTAGE	HZ	PH	F.L. AMPS
1	115/208/230	60	1	11.5

U.S. PATENT NUMBERS:
5,553,354/5,433,082/5,182,923
5,182,924/5,076,443/4,955,488
4,890,746/4,875,745/4,127,988
D273,298/D271,107/5,584,547
2,045,722/5,599,676

DO NOT CLEAN LABEL WITH SOLVENT DRL ENERGY SAVING LISTED COMMERCIAL REFRIGERATOR 334G UL

REMOTE UNITS (This section applies to remotes only!)

- Remote cabinets must be ordered as remote. We do not recommend converting from a standard self contained to remote system.
- All remote cabinets must be hard wired.
- No castors available.
- All remote cabinets come standard using 404A refrigerant.
- All remote units come standard with expansion valve, liquid line solenoid, heated condensate pan, and defrost timer when applicable.

- Contact True Technical Service for BTU requirements.
- No wiring necessary between cabinet and condensing unit.
- All remote condensing units purchased from True are 208/230 volts single phase.

If you have any questions regarding this section, please call True at 1-(800)-325-6152.

INSTALLATION / OPERATION INSTRUCTIONS

SHELVING INSTALLATION / OPERATION FOR TDC MODELS ONLY

SHELVING:

The metal frame on the interior sides of the unit can be adjusted to accommodate different sized containers. Slotted thumb screws can be unfastened from the interior walls to adjust the metal frame. (See image 1).

True provides container holders in each dipping cabinet. The container holders attached to the top of the ice cream containers. See image 2 to view the container holder.

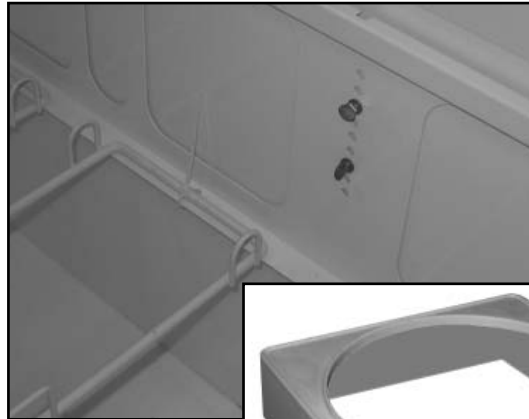

Image 1.

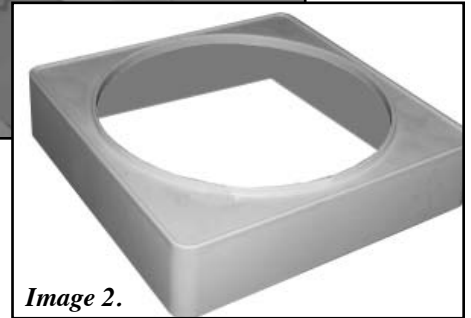

Image 2.

STORAGE / LOADING PRODUCT FOR TDC MODELS ONLY

STORAGE:

Some ice cream flavors have a higher sugar content than most. These flavors would contain ripple, maple syrup, and candy etc. The high sugar content flavors need a lower temperature for storage than others. These flavors would be best stored in the corners of the unit using the most freezing effect from the walls of the unit.

True's Dipping Cabinet is built for limited display time before deterioration begins to occur. Ice cream will need long term storage temperatures.

Ice cream should be immediately place into the Dipping cabinet after being removed from a delivery truck, walk-in freezer, or storage cabinet.

Dipping Cabinet will only maintain ice cream at the preset dipping temperature and is not designed as a hardening cabinet or long term storage.

Crystallization may occur if ice cream is allowed to warm up prior to placement in dipping cabinet resulting in loss in product quality.

LOADING PRODUCT:

NOTE:

When loading product do not exceed product load line labeled on the interior wall of TDC Models Only. (see image 3 below)



Image 3. (For TDC Models Only)

INSTALLATION / OPERATION INSTRUCTIONS

TEMPERATURE CONTROL ADJUSTMENT FOR HIGH ALTITUDE / DEFROST OPERATIONS

TEMPERATURE CONTROL:

(Temperature Control Adjustment For High Altitude Only!)

Temperature control is located at the back of the unit next to the rear grill. A flat head screw driver will need to be used when adjusting the temperature of the unit. (See image 1).

TERMS:

Cut-out - Temperature sensed by the controller that shuts the compressor off.

Cut-in - Temperature sensed by the controller that turns the compressor on.

REQUIRED TOOLS:

- Phillips Head Screwdriver
- 5/64" or 2 mm Allen Wrench
- T-7 Torx Wrench

_____ **STEP 1** _____

Unplug the cooler.

_____ **STEP 2** _____

Remove the screws that secure the temperature control to the inset box lower left side of the cabinet (when facing the front of the cabinet).

_____ **STEP 3** _____

Pull out gently from cabinet.

_____ **STEP 4** _____

For high elevation installations, it may be necessary to "warm-up" the set points. To make the adjustment, insert the appropriate tool in each adjustment screw and turn 1/4 of a revolution clockwise (to the right). This procedure will adjust both the cut-in and cut-out about 2°F warmer.

_____ **STEP 5** _____

Make sure to reconnect the pink wire to the proper spade terminal when reinstalling.

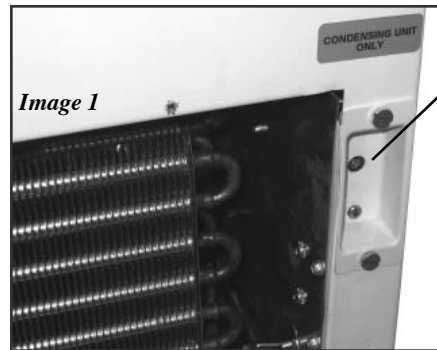

Image 1

Temperature Control

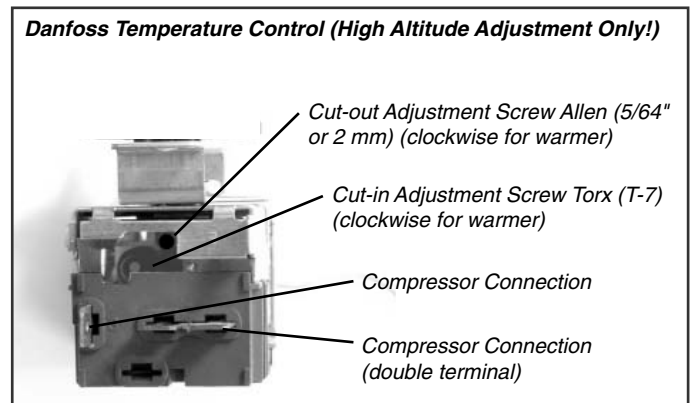

Image 2

Danfoss Temperature Control (High Altitude Adjustment Only!)

Cut-out Adjustment Screw Allen (5/64" or 2 mm) (clockwise for warmer)

Cut-in Adjustment Screw Torx (T-7) (clockwise for warmer)

Compressor Connection

Compressor Connection (double terminal)

MANUAL DEFROST:

The unit will need to be manually defrosted. Unplug unit until all frost is gone. The manual defrost frequency will depend on the units usage, environment, and the amount of frost.

NOTE:

REMEMBER TO CONNECT DRAIN HOSE TO A GARDEN TYPE HOSE THAT IS ROUTED TO A FLOOR DRAIN WHEN MANUALLY DEFROSTING UNIT.

If ice builds up on interior walls- (TDC Units Only)

- Remove product, unplug and roll unit so defrost plug is above floor drain (or large flat pan).
- Remove plug and allow ice to melt and drain. Do not scrape interior of cabinet to loosen ice, as this will damage the cabinet. Allow cabinet to defrost with power off.
- When ice has melted wipe up and water left in the freezer floor.
- Be sure to replace defrost plug before moving freezer back in position.
- Allow freezer to refrigerate and cycle before placing wire baskets and product back into freezer.

MAINTENANCE, CARE & CLEANING

CLEANING THE CONDENSER COIL

When using electrical appliances, basic safety precautions should be followed, including the following

True Dipping Cabinets are equipped with reversing fan motors keeping the condenser coil cleaner than the conventional fan motors.

TOOLS REQUIRED:

- Phillips screwdriver
- Stiff bristle brush
- Adjustable Spanner or Mole Grips
- Vacuum Cleaner

Step 1

Disconnect power to unit.

Step 2

Removing the four 1/4" hex head screws to allow removal of the rear grill. (See image 1).

Step 3

Remove bolts anchoring compressor assembly to frame rails and carefully slide out. (tube connections are flexible)

Step 4

Clean off accumulated dirt from the condenser coil and the fan with a stiff bristle brush. (See image 2).

Step 5

Lift cardboard cover above fan at plastic plugs and carefully clean condenser coil and fan blades.

Step 6

After brushing condenser coil vacuum dirt from coil, and interior floor. (See image 3).

Step 7

Replace cardboard cover. Carefully slide compressor assembly back into position and replace bolts.

Step 8

Reinstall rear grill assembly onto unit. Tighten all screws.

Step 9

Connect unit to power and check to see if compressor is running.



Image 1

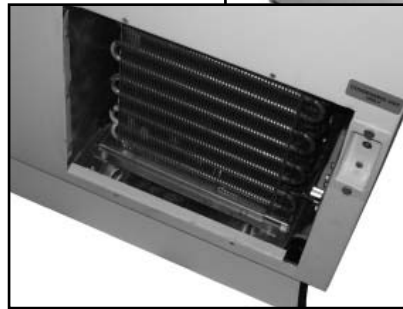

THE CLEANING OF THE CONDENSER IS NOT COVERED BY THE WARRANTY!

Condensers accumulate dirt and require cleaning every 30 days. Dirty condensers result in compressor failure, product loss, and lost sales... which are not covered by warranty.

If you keep the Condenser clean you will minimize your service expense and lower your electrical costs. The Condenser requires scheduled cleaning every thirty days or as needed.

Air is pulled through the Condenser continuously, along with dust, lint, grease, etc.

*A dirty Condenser can result in **NON-WARRANTED** part & Compressor Failures, Product Loss, and Lost Sales.*

Proper cleaning involves removing dust from the Condenser. By using a soft brush, or vacuuming the Condenser with a shop vac, or using CO₂, nitrogen, or pressurized air.

If you cannot remove the dirt adequately, please call your refrigeration service company.

If you have any questions, please call True Manufacturing at 636-240-2400 or 800-325-6152 and ask for the Service Department. Service Department Availability Monday-Friday 7:30 a.m. to 5:30 p.m. and Saturday 7:45 a.m. to 11:45 a.m. CST.

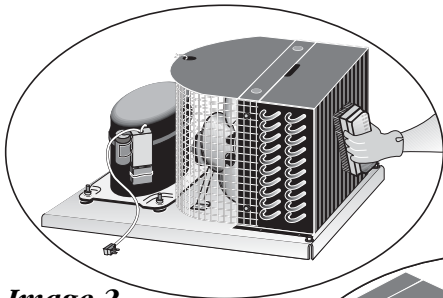

Image 2

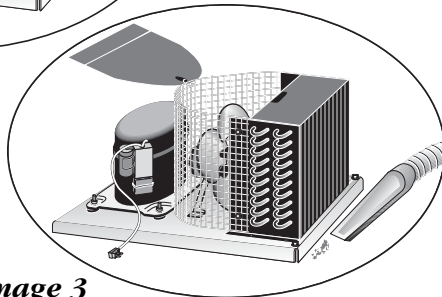

Image 3

MAINTENANCE, CARE & CLEANING

MAINTENANCE CLEANING

CLEANING: (Before cleaning out the interior locate the drain hose in the rear grill area and be prepared to open the line and drain the water into a pan or floor drain. This will be the same for TDC and THDC models)

The lid can be removed from the cabinet. (See image 1 for TDC models and image 2 for THDC models). If the lid has been removed, wash it with nonabrasive soap or detergent and water. Use the bare hand to feel and dislodge any caked soil. Rinse thoroughly with clean water. Do not use hard, rough cloths that will scratch the surface of the lid. Dry with a clean, damp chamois. The interior can be cleaned but, before doing so make sure the drain at the bottom of the cabinet is open and the drain hose in the rear grill is at a floor drain.

MAGNETIC ICE BREAKER (ONLY ON TDC MODELS):

Magnetic ice breaker were designed to provide a fast and effective way to remove the frost from the wall above the product. Frost accumulation reduces the refrigeration effectiveness as it increases in thickness.

The frequency at which to clean the ice breaker is a function of the store operation as a starting point. Thaw and clean at the beginning of each day. Thaw under warm water or on a counter top at room temperature until ice breaker is flexible and clear of frost. Wipe dry to prevent returning moisture to cabinet.

NOTE:

Magnetic ice breakers are soft and flexible at room temperature but, they will become relatively rigid when they have been exposed to low temperature from the cabinet.

DO NOT FOLD MAGNETIC ICE BREAKERS! Reinstall the ice breakers by forming around corners. The ice breakers are magnetic and they will attach tightly to the wall and resist sliding in place. To overcome this apply from one end and roll into place. (See image 3).



Image 1. The lid on TDC models can be removed by lifting it out of the hinge bracket.

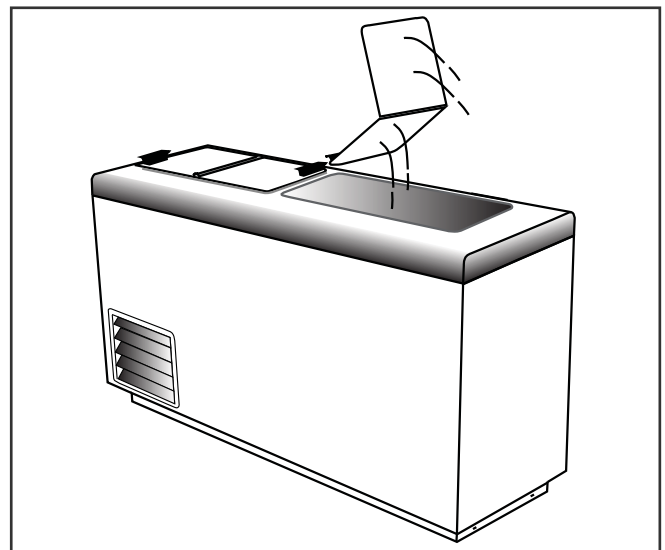

Image 2. The lid can be removed by simply lifting it out.

Magnetic Frost Shield



Image 3. (ONLY FOR TDC MODELS).

MAINTENANCE, CARE & CLEANING

STAINLESS STEEL EQUIPMENT CARE AND CLEANING

CAUTION: Do not use any steel wool, abrasive or chlorine based products to clean stainless steel surfaces. Please ensure that you use appropriate products when cleaning and polishing your True unit. Cleaners containing chlorine must not be used as these will attack the stainless steel causing damage and in some cases corrosion. Your supplier of cleaning products should be able to advise you of the products suitable to keep your True unit looking like new.

• Stainless Steel Opponents

There are three basic things which can break down your stainless steel's passivity layer and allow corrosion to rear its ugly head.

- 1) Scratches from wire brushes, scrapers, and steel pads are just a few examples of items that can be abrasive to stainless steel's surface.
- 2) Deposits left on your stainless steel can leave spots. You may have hard or soft water depending on what part of the country you live in. Hard water can leave spots. Hard water that is heated can leave deposits if left to sit too long. These deposits can cause the passive layer to break down and rust your stainless steel. All deposits left from food prep or service should be removed as soon as possible.
- 3) Chlorides are present in table salt, food, and water. Household and industrial cleaners are the worst type of chlorides to use.

8 steps that can help prevent rust on stainless steel:**1. Using the correct cleaning tools**

Use non-abrasive tools when cleaning your stainless steel products. The stainless steel's passive layer will not be harmed by soft cloths and plastic scouring pads. Step 2 tells you how to find the polishing marks.

2. Cleaning along the polish lines

Polishing lines or "grain" are visible on some stainless steels. Always scrub parallel to visible lines on some stainless steels. Use a plastic scouring pad or soft cloth when you cannot see the grain.

3. Use alkaline, alkaline chlorinated or non-chloride containing cleaners

While many traditional cleaners are loaded with chlorides, the industry is providing an ever increasing choice of non-chloride cleaners. If you are not sure of your cleaner's chloride content contact your cleaner supplier. If they tell you that your present cleaner contains chlorides, ask if they have an alternative. Avoid cleaners containing quaternary salts as they can attack stainless steel, causing pitting and rusting.

4. Water Treatment

To reduce deposits, soften the hard water when possible. Installation of certain filters can remove corrosive and distasteful elements. Salts in a properly maintained water softener can be to your advantage. Contact a treatment specialist if you are not sure of the proper water treatment.

5. Maintaining the cleanliness of your food equipment

Use cleaners at recommended strength (alkaline, alkaline chlorinated or non-chloride). Avoid build-up of hard stains by cleaning frequently. When boiling water with your stainless steel equipment, the single most likely cause of damage is chlorides in the water. Heating any cleaners containing chlorides will have the same damaging effects.

6. Rinse

When using chlorinated cleaners you must rinse and wipe dry immediately. It is better to wipe standing cleaning agents and water as soon as possible. Allow the stainless steel equipment to air dry. Oxygen helps maintain the passivity film on stainless steel.

7. Hydrochloric acid (muriatic acid) should never be used on stainless steel**8. Regularly restore/passivate stainless steel**

MAINTENANCE, CARE & CLEANING

STAINLESS STEEL EQUIPMENT CARE AND CLEANING

Recommended cleaners for certain situations / environments of stainless steel

- A) Soap, ammonia and detergent medallion applied with a cloth or sponge can be used for routine cleaning.
- B) Arcal 20, Lac-O-Nu Ecoshine applied provides barrier film for fingerprints and smears.
- C) Cameo, Talc, Zud First Impression is applied by rubbing in the direction of the polished lines for stubborn stains and discoloring.
- D) Easy-off and De-Grease It oven aid are excellent for removals on all finishes for grease-fatty acids, blood and burnt-on foods.
- E) Any good commercial detergent can be applied with a sponge or cloth to remove grease and oil.
- F) Benefit, Super Sheen, Sheila Shine are good for restoration / passivation.

NOTE:

The use of stainless steel cleaners or other such solvents is not recommended on plastic parts. Warm soap and water will suffice.

LIGHT BULB REPLACEMENT FOR TDC MODELS

LIGHT BULB REPLACEMENT:

When replacing the light bulb make sure the light switch is turned off. (See image 1).

- Hold firmly on the end of the light bulb and pull toward the center of the cabinet. The lampholders are spring activated so the bulb can easily be replaced. (See image 2).
- When installing a new bulb make sure the prongs at the end of the bulb seat appropriately into the lampholder.



Image 2..

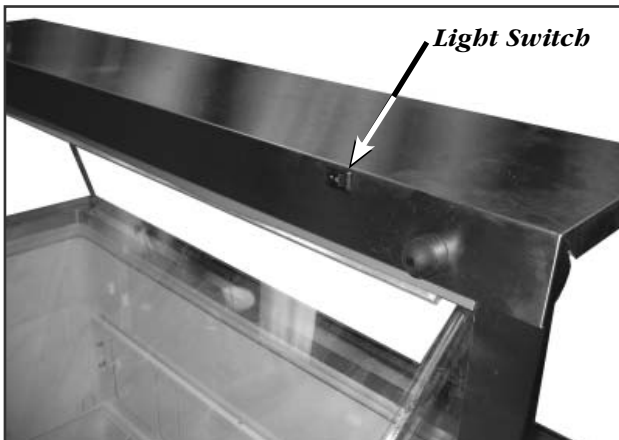

Image 1.



Image 3.



WARRANTY INFORMATION (U.S.A. & CANADA ONLY!)

ONE YEAR PARTS & LABOR WARRANTY

TRUE warrants to the original purchaser of every new TRUE refrigerated unit, the cabinet and all parts thereof, to be free from defects in material or workmanship, under normal and proper use and maintenance service as specified by TRUE and upon proper installation and start-up in accordance with the instruction packet supplied with each TRUE unit. TRUE's obligation under this warranty is limited to a period of one (1) year from the date of original installation or 15 months after shipment date from TRUE, whichever occurs first.

Any part covered under this warranty that are determined by TRUE to have been defective within one (1) year of original installation or fifteen (15) months after shipment date from manufacturer, whichever occurs first, is limited to the repair or replacement, including labor charges, of defective parts or assemblies. The labor warranty shall include standard straight time labor charges only and reasonable travel time, as determined by TRUE.

ADDITIONAL FOUR YEAR COMPRESSOR WARRANTY

In addition to the one (1) year warranty stated above, TRUE warrants its hermetically and semi-hermetically sealed compressor to be free from defects in both material and workmanship under normal and proper use and maintenance service for a period of four (4) additional years from the date of original installation but not to exceed five (5) years and three (3) months after shipment from the manufacturer.

Compressors determined by TRUE to have been defective within this extended time period will, at TRUE's option, be either repaired or replaced with a compressor or compressor parts of similar design and capacity.

The four (4) year extended compressor warranty applies only to hermetically and semi-hermetically sealed parts of the compressor and does not apply to any other parts or components, including, but not limited to, cabinet, paint finish, temperature control, refrigerant, metering device, driers, motor starting equipment, fan assembly or any other electrical component, etcetera.

404A/134A COMPRESSOR WARRANTY

The four year compressor warranty detailed above will be voided if the following procedure is not carefully adhered to:

1. This system contains R404A or R134A refrigerant and polyol ester lubricant. The polyol ester lubricant has rapid moisture absorbing qualities. If long exposure to the ambient conditions occur, the lubricant must be removed and replaced with new. For oil amounts and specifications please call True technical service department (800-325-6152). Failure to comply with recommended lubricant specification will void the compressor warranty.

2. Drier replacement is very important and must be changed when a system is opened for servicing. A drier using XH-7 desiccant or an exact replacement solid core drier must be used. The new drier must also be the same capacity as the drier being replaced.

3. Micron level vacuums must be achieved to insure low moisture levels in the system. 500 microns or lower must be obtained.

WARRANTY CLAIMS

All claims for labor or parts must be made directly through TRUE. All claims should include: model number of the unit, the serial number of the cabinet, proof of purchase, date of installation, and all pertinent information supporting the existence of the alleged defect.

In case of warranty compressor, the compressor model tag must be returned to TRUE along with above listed information. Any action or breach of these warranty provisions must be commenced within one (1) year after that cause of action has occurred.

WHAT IS NOT COVERED BY THIS WARRANTY

TRUE's sole obligation under this warranty is limited to either repair or replacement of parts, subject to the additional limitations below. This warranty neither assumes nor authorizes any person to assume obligations other than those expressly covered by this warranty.

NO CONSEQUENTIAL DAMAGES. TRUE IS NOT RESPONSIBLE FOR ECONOMIC LOSS; PROFIT LOSS; OR SPECIAL, INDIRECT, OR CONSEQUENTIAL DAMAGES, INCLUDING WITHOUT LIMITATION, LOSSES OR DAMAGES ARISING FROM FOOD OR PRODUCT SPOilage CLAIMS WHETHER OR NOT ON ACCOUNT OF REFRIGERATION FAILURE.

WARRANTY IS NOT TRANSFERABLE. This warranty is not assignable and applies only in favor of the original purchaser/user to whom delivered. ANY SUCH ASSIGNMENT OR TRANSFER SHALL VOID THE WARRANTIES HEREIN MADE AND SHALL VOID ALL WARRANTIES, EXPRESS OR IMPLIED, INCLUDING ANY WARRANTY OF MERCHANTABILITY OR FITNESS FOR A PARTICULAR PURPOSE.

IMPROPER USAGE. TRUE ASSUMES NO LIABILITY FOR PARTS OR LABOR COVERAGE FOR COMPONENT FAILURE OR OTHER DAMAGES RESULTING FROM IMPROPER USAGE OR INSTALLATION OR FAILURE TO CLEAN AND/OR MAINTAIN PRODUCT AS SET FORTH IN THE WARRANTY PACKET PROVIDED WITH THE UNIT.

ALTERATION, NEGLIGENCE, ABUSE, MISUSE, ACCIDENT, DAMAGE DURING TRANSIT OR INSTALLATION, FIRE, FLOOD, ACTS OF GOD. TRUE is not responsible for the repair or replacement of any parts that TRUE determines have been subjected after the date of manufacture to alteration, neglect, abuse, misuse, accident, damage during transit or installation, fire, flood, or act of God.

IMPROPER ELECTRICAL CONNECTIONS. TRUE IS NOT RESPONSIBLE FOR THE REPAIR OR REPLACEMENT OF FAILED OR DAMAGED COMPONENTS RESULTING FROM ELECTRICAL POWER FAILURE, THE USE OF EXTENSION CORDS, LOW VOLTAGE, OR VOLTAGE DROPS TO THE UNIT.

NO IMPLIED WARRANTY OF MERCHANTABILITY OR FITNESS FOR A PARTICULAR PURPOSE: THERE ARE NO OTHER WARRANTIES, EXPRESSED, IMPLIED OR STATUTORY, EXCEPT THE ONE (1) YEAR PARTS & LABOR WARRANTY AND THE ADDITIONAL FOUR (4) YEAR COMPRESSOR WARRANTY AS DESCRIBED ABOVE. THESE WARRANTIES ARE EXCLUSIVE AND IN LIEU OF ALL OTHER WARRANTIES, INCLUDING IMPLIED WARRANTY AND MERCHANTABILITY OR FITNESS FOR A PARTICULAR PURPOSE. THERE ARE NO WARRANTIES WHICH EXTEND BEYOND THE DESCRIPTION ON THE FACE HEREOF.

OUTSIDE U.S.: This warranty does not apply to, and TRUE is not responsible for, any warranty claims made on products sold or used outside the United States.

REMOTE CONDENSERS: True warrants the original purchaser of the remote cabinet one year parts and labor coverage for all cabinet parts thereof to be free from defects in material or workmanship, under normal and proper use and maintenance service, as specified by True. This warranty is limited to the cabinet only. True assumes no liability for remote condensing units.