



**Standard Commercial Treadmill
Owner's Manual
C936i**

IMPORTANT SAFETY INSTRUCTIONS

When using the C936i treadmill, always follow basic precautions, including the following:

- To ensure your safety and to protect the unit, read all the instructions before assembling and using the treadmill.
- To ensure the proper use and safety of the treadmill, make sure that all users read this manual. Please make this manual a part of your club's training program. Remind the club users that before beginning any fitness program, they should obtain complete physical examinations from their physicians.

Il est conseillé de subir un examen médical complet avant d'entreprendre tout programme d'exercice. Si vous avez des étourdissements ou des faiblesses, arrêtez les exercices immédiatement.

DANGER — To reduce the risk of electrical shock, always unplug the unit from its power source before cleaning or performing any maintenance tasks.

WARNING — To reduce the risk of burns, fire, electric shock, or injury to persons, take the following precautions:

- Do not allow children or those unfamiliar with its operation on or near the treadmill. Do not leave children unsupervised around the treadmill.
- Never leave the treadmill unattended. Unplug the unit from the power outlet when it is not in use, before cleaning it, and before putting on or taking off parts. Do not adjust the running belt when someone is standing on the unit.
- Assemble and operate the treadmill on a solid, level surface. Locate the treadmill a few feet from walls or furniture. Check the unit before each use and verify that all fasteners are secure. Maintain the treadmill in good working condition.
- Use the treadmill only for its intended use as described in this manual. Do not use accessory attachments that are not recommended by the manufacturer; such attachments might cause injuries.
- If you purchased the optional chest strap, review the guidelines found in the *Precor Heart Rate Option Owner's Manual* that is supplied with that option.
- Never operate the unit if it is damaged, if it is not working properly, if it has been dropped, or if it has been dropped in water. Return the unit to a service center for examination and repair.
- Keep all electrical components such as the motor, power cord, and I/O switch, away from liquids to prevent shock. Do not set anything on the handrail, display console, or hood. Place liquids, magazines and books in the appropriate receptacles.
- Keep the power cord away from heated surfaces.
- Do not operate the treadmill where aerosol (spray) products are being used or where oxygen is being administered.
- Do not use outdoors.
- The security clip must be attached at waist level prior to beginning a workout. A cord connects the security clip to the red STOP button on the console. If a user encounters difficulties, a strong tug on the security cord or a quick tap on the red STOP button will stop the running belt.
- Use care when getting on or off the treadmill. Use the stationary handrail whenever possible. Place your feet firmly on the right and left side platforms before the running belt begins moving (prior to a workout). Step onto the running belt when the speed is at or below 1 mph (1.6 kph).

IMPORTANT SAFETY INSTRUCTIONS

- Never step off the treadmill while the running belt is moving. Keep your body and head facing forward. Never attempt to turn around on the treadmill.
- Never turn ON the treadmill when someone is standing on the machine.
- Never block the air openings on the hood while operating the treadmill. Keep the air openings clean and free of lint, hair, or anything that might impeded the free flow of air. Never drop or insert objects into any opening.
- Wear proper exercise clothing and shoes during a workout—no loose clothing. Tie long hair back. Keep all loose towels away from the running surface. The running belt will not stop immediately if an object becomes caught in the belt or rollers.
- Do not rock the unit. Do not stand on the display console or hood.
- Do not overexert yourself or work to exhaustion. If you feel any pain or abnormal symptoms, stop your workout immediately and consult your physician.

SAFETY APPROVAL

When identified with the ETL-c logo, the treadmill has been tested and conforms to the requirements of CAN/CSA-E-335-1/3-94, Safety of Household and Similar Electrical Appliances.

GROUNDING INSTRUCTIONS

The C936i treadmill must be grounded. If it should malfunction or break down, grounding provides a path of least resistance for electric current which reduces the risk of electrical shock. The C936i treadmill is equipped with a power cord having an equipment-grounding conductor and a grounding plug. The plug must be inserted into an appropriate outlet that is properly installed and grounded in accordance with all local codes and ordinances. If you do not follow these *Grounding Instructions*, you could void the Precor Limited Warranty.

DANGER — Improper connection of the equipment-grounding conductor can result in a risk of electric shock. Check with a qualified electrician or service person if you are in doubt as to whether the treadmill is properly grounded. Do not modify the plug provided with the treadmill. If it doesn't fit the outlet, get a proper outlet installed by a qualified technician.

Diagram 1
Correct power outlet for U.S. Markets:
120-volt and 240-volt plugs.

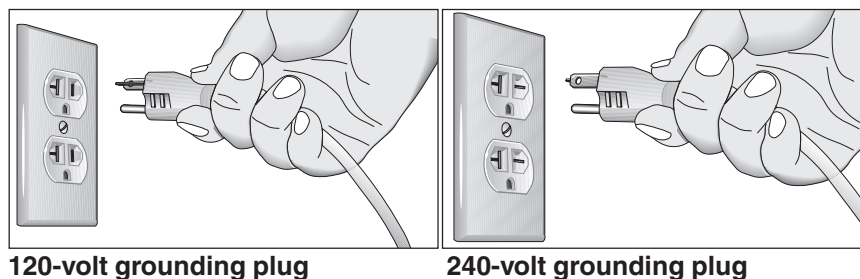

120-volt grounding plug

240-volt grounding plug

120V Units and 240V Units Designated for U.S. Markets

The C936i treadmill must be connected to a dedicated, grounded circuit. A 20 amp dedicated circuit is recommended. The treadmill is factory-equipped with a specific power supply cord to permit connection to a proper electric circuit as shown in Diagram 1. Make sure that the treadmill is connected to an outlet having the same configurations as the plug. No adapter should be used with this product.

Table of Contents

Important Safety Instructions	2
Safety Approval	3
Grounding Instructions	3
Radio Frequency Interference (RFI)	6
European Applications	6
Obtaining Service	7
About this Manual	7
Unpacking the Treadmill	9
Standard Equipment	9
Other Equipment	9
Hardware Kit	10
Additional Tools Needed	10
Setting Up the Treadmill	11
Installation Requirements	11
Assembly Instructions	11
Turning the Unit ON and OFF	21
Checking the Alignment of the Running Belt	22
Club Information	23
Changing the Club Settings	23
Determining the Units of Measure	24
Determining the Club Speed Limit	25
Setting a Workout Time Limit	25
Setting a Pause Time Limit	25
Viewing the Odometer, Hours of Use, Software Version, Error Log and Serial Number	26
Using CSAFE Standard Equipment	27
The C936i Display	28
Features on the Display Console	28
SmartRate® Display	29
Setup Mode and Prompts	29
The Setup Mode and the QuickStart Feature	30
Display Features During a Workout	31
Keys on the Display Console	33
Changing the Display Features Using the SELECT Key	35

Table of Contents

Exercising on the Treadmill.....	36
Using the Security Clip	36
Using the Handrails	36
Using the Heart Rate “Touch” Capability	36
Keypad Tips	37
Workout Tips	37
Quick Steps to Working Out	37
Cooling Down After a Workout	39
Pause, Workout Summary, and Exit Features	40
Programs	41
The Heart Rate Feature	41
Using the SmartRate® Feature	41
Manual Mode and the QUICKSTART Key	42
Cross Country Program	43
Interval Program	43
Weight Loss Program	44
Random Program	44
Heart Rate Program	45
Maintenance	46
Inspection	46
Cleaning the Equipment	46
Aligning the Running Belt	47
Storing the Chest Strap	48
Servicing the Treadmill	48
Long Term Storage	48
Commercial Warranty Registration Card	49
Commercial Warranty	51
Specifications	back cover

RADIO FREQUENCY INTERFERENCE (RFI)

Federal Communications Commission Part 15

The treadmill has been tested and found to comply with:

- The IEC EMC Directive (international electromagnetic compatibility certification)
- The limits for a Class A digital device, pursuant to Part 15 of the FCC Rules. These limits are designed to provide reasonable protection against harmful interference in a commercial installation. The treadmill generates, uses, and can radiate radio frequency energy and, if not installed and used in accordance with the owner's manual instructions, may cause harmful interference to radio communications. Operation of the treadmill in a residential area is likely to cause harmful interference. If this occurs, the user will be required to correct the interference at his or her own expense.

CAUTION — Per FCC rules, changes or modifications to the treadmill not expressly approved by Precor, could void the user's authority to operate the equipment.

Canadian Department of Communications

This digital apparatus does not exceed the Class A limits for radio noise emissions from digital apparatus set out in the Radio Interference Regulations of the Canadian Department of Communications.

Le présent appareil numérique n'émet pas de bruits radioélectriques dépassant les limites applicables aux appareils numériques de la Class A prescrites dans le Règlement sur le brouillage radioélectrique édicté par le ministère des Communications du Canada.

EUROPEAN APPLICATIONS

This product conforms to the requirements of the European Council Directive 89/336/EEC, *Electromagnetic Compatibility* and has been tested to the following standards:

EN55022, Limits & Methods of Measurement of Radio Interference, Information Technology Equipment. In a domestic environment, this product may cause radio interference, in which case the user is responsible to take adequate measures to alleviate the interference.

EN50082-1, Generic Immunity Standard for Residential, Commercial and Light Industrial Products.

This product additionally conforms to the requirements of the European Council Directive 73/23/EEC, *Low Voltage Directive* and has been tested to the following standard:

IEC 335-1, Safety of Household and similar Electrical Appliances.

OBTAINING SERVICE

Do not attempt to service the treadmill yourself except for the maintenance tasks described in this manual. The treadmill does not contain any user-serviceable parts. For information about product operation or service, visit the Precor Web Site at www.precor.com or contact an authorized Precor Commercial Products Customer Support Representative at 1-888-665-4404.

To help customer support personnel expedite your call, have your serial number available. The serial number can be found on the shipping container or on the label near the power receptacle. If you have any questions regarding the treadmill, use the model and serial numbers whenever you call a Precor dealer or Commercial Products Customer Support Representative.

Model number: **C936i**

Unit number: _____ Serial number: _____

Unit number: _____ Serial number: _____

Unit number: _____ Serial number: _____

ABOUT THIS MANUAL

This manual includes instructions for installing and using the treadmill. To maximize the use of the treadmill, please study this manual thoroughly. The manual uses the following conventions for identifying special information:

Note: Contains additional information.

Important: *Indicates information to which you should pay special attention.*

CAUTION: Indicates steps or information necessary to prevent harm to yourself or damage to the equipment.

WARNING: Provides instructions to prevent electrical damage to the equipment and injuries to yourself.

DANGER: Indicates steps you must take to prevent electrical shock.

C O M M E R C I A L P R O D U C T S D I V I S I O N

Notes:

Unpacking the Treadmill

Thank you for purchasing the Precor C936i treadmill. Built to the exacting standards of the health club environment, the treadmill is intended for commercial use and can withstand the rigors of daily club use with little maintenance.

Important: Before using the treadmill, we urge you to familiarize yourself and your staff with the entire Owner's Manual. Understanding this manual will help you and your customers use the treadmill safely and successfully.

Your treadmill is carefully inspected before shipment so it should arrive in good operating condition. Precor ships the unit in the following pieces:

- | | |
|--|---|
| <input type="checkbox"/> Base frame assembly | <input type="checkbox"/> Power cord |
| <input type="checkbox"/> Right and left upright supports | <input type="checkbox"/> Hardware kit |
| <input type="checkbox"/> Display console | <input type="checkbox"/> Owner's Manual |
| <input type="checkbox"/> Right and left handrails | |

CAUTION: This unit weighs over 320 pounds (146 kilograms). To prevent injury to yourself or damage to the equipment, obtain appropriate assistance before removing the unit from the pallet.

If any items are missing, refer to *Obtaining Service* on page 7.

STANDARD EQUIPMENT

The treadmill incorporates the Precor SmartRate® and Heart Rate features into its display console. Devices, such as FitLinxx®, that are CSAFE compatible, can also be attached.

The Precor “touch” heart rate is standard on the C936i and provides two metal strips, called “grips,” on the center portion of the handrails. When a user places both hands on the grips, a heart rate is transmitted to the receiver.

Note: If a user does not wish to use the touch-sensitive hand grips, an optional chest strap can be purchased and worn. The chest strap transmits the user's heart rate and it appears as a number in the HEART RATE display.

Important: The user must place the left hand on the left handrail grip and their right hand on the right handrail grip to transmit their heart rate. Placing one hand on a grip does not provide sufficient signal to display the user's heart rate.

OTHER EQUIPMENT

Optional equipment available through your dealer includes:

- Chest strap.

If you are interested in obtaining Precor option kits for your unit, check with your dealer. For customer support, see *Obtaining Service* on page 7.

HARDWARE KIT

After unpacking the treadmill, open the hardware kit (refer to Diagram 2) and make sure that you have the following items:

- (A) four 2-inch long socket head screws — mount upright supports to base
- (B) four barrel spacers — place on 2-inch screws
- (C) ten $\frac{3}{4}$ -inch long socket head screws
- (D) sixteen flat washers
- (E) two $1\frac{1}{4}$ -inch socket head screws — handrail clamp assembly
- (F) four large diameter washers — place on handrail end cap screws
- (G) four 1-inch socket head screws — handrail mounting bracket
- (H) $\frac{1}{4}$ -inch hex key — 3 inches by 10 inches

If any items are missing, refer to *Obtaining Service* on page 7.

Note: After assembling the treadmill, you will have four $\frac{3}{4}$ -inch long socket head screws (C) and two flat washers (D) remaining. You can discard them if you wish. Also, be sure to store the hex key in a secure place. It is used for specific maintenance procedures that are described in the manual.

Diagram 2 Hardware kit.

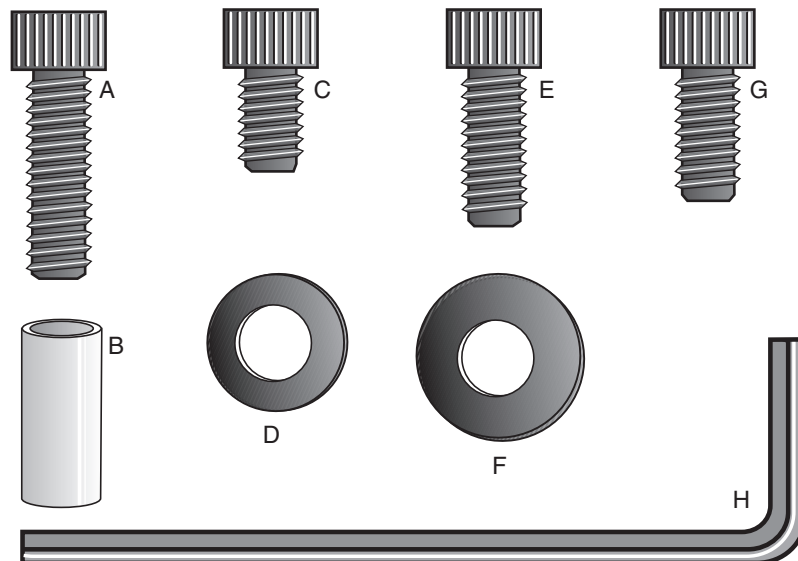

ADDITIONAL TOOLS NEEDED

Obtain the following tools *before* assembling the treadmill.

- Wire cutter
- Bubble level
- $\frac{1}{2}$ -inch box end wrench
- String

Setting Up the Treadmill

You do not need any special knowledge or experience to set up the treadmill. However, because of the size and weight of the treadmill, you will need to obtain assistance.

INSTALLATION REQUIREMENTS

Follow these installation requirements when installing the treadmill. *If you do not install the treadmill according to the following guidelines, you could void the Precor Limited Warranty.*

- **Set up the treadmill on a solid, flat surface.** Unpack and assemble the treadmill close to where you plan to use it. Make sure that the flat surface under the unit is smooth and level. A level unit is required for the user's safety and proper operation.
- **Provide ample space around the unit.** Open space around the unit makes for a safer mount and dismount.
- **Fill out and mail the warranty registration card.** Be sure that the treadmill is turned OFF. The serial number can be found on the shipping container or on the label near the power receptacle. Write the serial number onto the Precor Limited Warranty registration card found on the back cover of this manual. Refer to *Obtaining Service* on page 7 and write the number(s) there as well.
- **Use the appropriate voltage, dedicated circuit, and grounding as specified on the treadmill.** The treadmill is available in both 120-volt and 240-volt models. Refer to the treadmill's identification label to determine the voltage that your treadmill requires. Both the 120-volt and 240-volt models require a **dedicated** circuit. A 20 amp circuit is recommended.

CAUTION: Do not use a non-grounded outlet or transformer. Do not remove or otherwise bypass the plug with an adapter. Electrical damage can occur and void the Precor Limited Warranty if the treadmill is connected to an improper power source.

ASSEMBLY INSTRUCTIONS

Take the following steps to assemble the treadmill.

1. **Obtain adult assistance.** Have your assistants help place the shipping carton close to the location where you plan to use the treadmill. Break down the side walls of the shipping carton so that they lie flat. Remove the loose contents.

CAUTION: To avoid injury and ensure your safety, get assistance before lifting the treadmill off the pallet and rolling it onto the floor. Do not drop the unit.

2. **Make sure that the power switch is OFF.** Check the ON/OFF power switch on the front of the treadmill. Place the switch in the O (OFF) position. Make sure that the treadmill is **not** plugged into a power source.

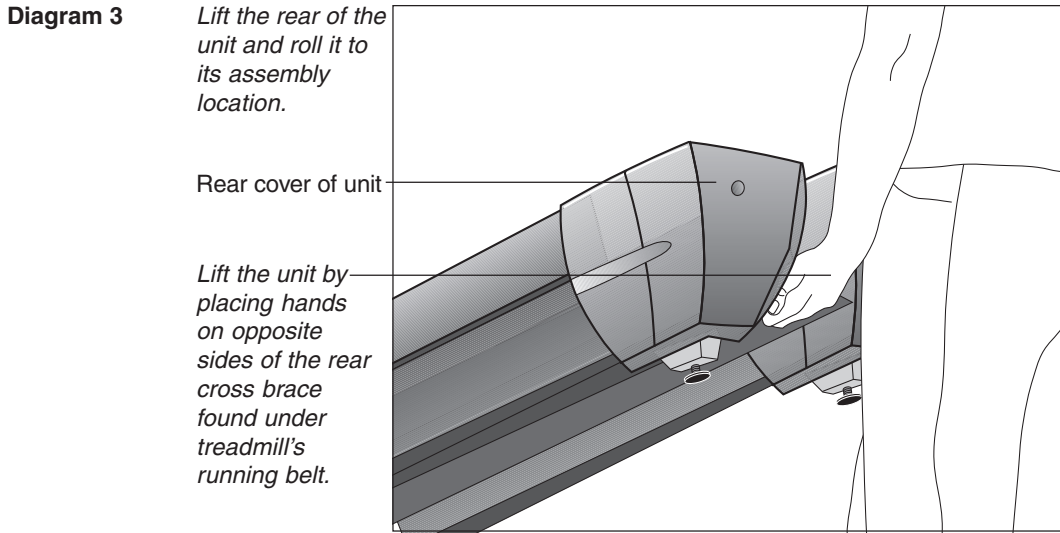

- 3. Move the treadmill.** Diagram 3. To properly lift the rear end and roll it on its front wheels, review Diagram 3. To avoid injury to yourself or damage to the unit, ask for help in placing the treadmill where you plan to use it.

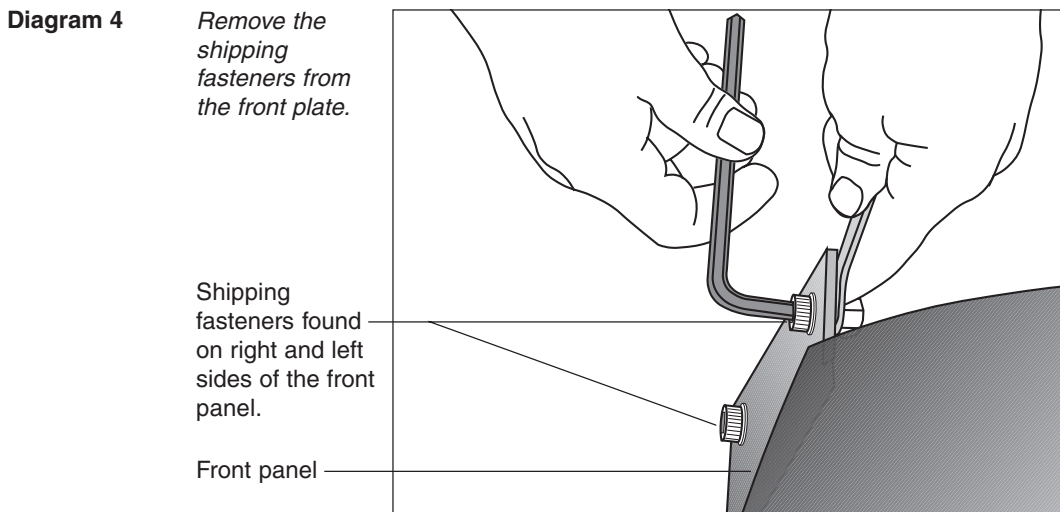

- 4. Remove the shipping fasteners from the front panel.** Diagram 4. With the supplied hex key and a 1/2-inch box end wrench, loosen and remove the four bolts, washers and nuts on the front panel. These fasteners are used during shipping to hold the front panel in place. Discard the fasteners.
- 5. Remove any tape or wire ties that secure the display cable to the side of the unit.**

CAUTION: To avoid damage to the display cable, read the following steps carefully. Damage to the cable due to improper assembly is not covered by the Precor Limited Warranty.

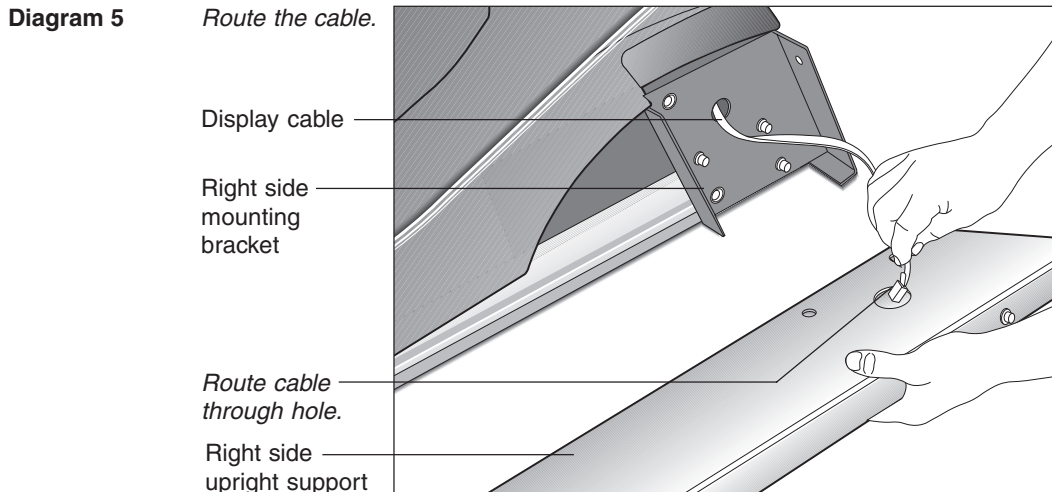

6. **Route the display cable.** Diagram 5. Unwrap the cable and remove any kinks. Have an assistant hold the right upright support close to the base while you route the cable through it.

Note: Attaching a string to the cable with a washer tied to the opposite end of the string may help you route the cable through the upright support.

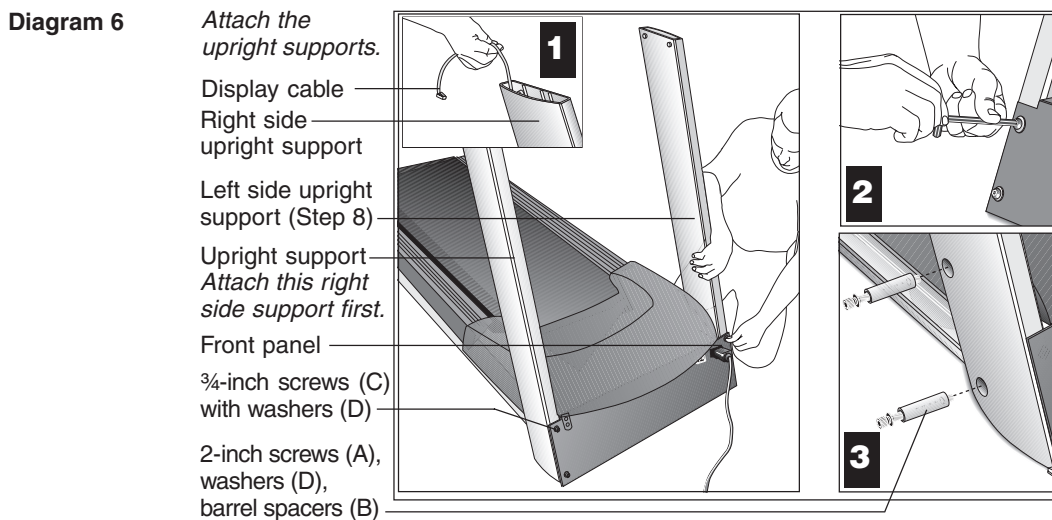

7. **Attach the right side upright support to the base assembly.** Diagram 6, #1. Take the following steps to align the right side upright support with the base assembly mounts while your assistant keeps tension on the cable:

Important: Do not securely tighten the screws until after the unit has been fully assembled. Make sure that the bolt and spacer do not pinch the cable.

 - a. Place a washer (D) onto each of two 3/4-inch screws (C). Thread the screws through the front panel and into the upright support. Leave room for adjustments.
 - b. Place a washer (D) and barrel spacer (B) on each of two 2-inch screws (A). See Diagram 6, #3. Insert the screws through the upright support and thread them into the base mounts.

8. **Attach the left side upright support to the base assembly.** Refer to Diagram 6. Align the upright support with the base assembly mounting bracket and secure it by following steps 7a and 7b.

Diagram 7

Install the display console.

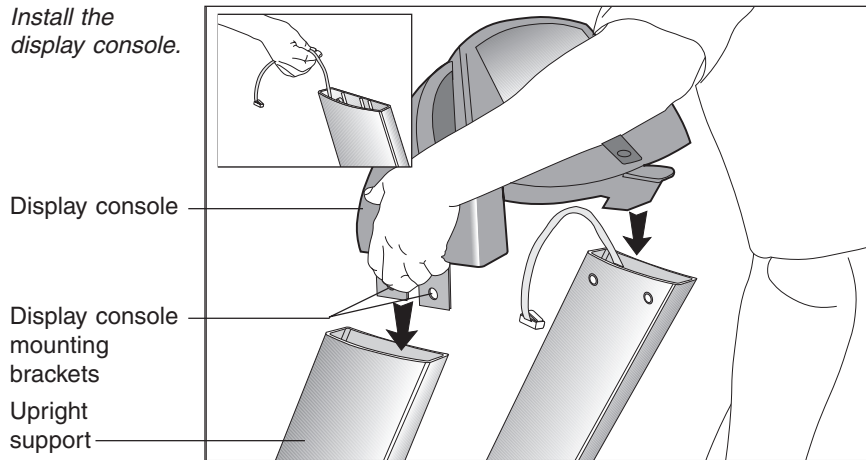

9. **Secure the display console to the upright supports.** Diagram 7.
 - a. Make sure that the cable is routed through the top of the upright support. Have an assistant hold onto the cable (see inset).

Diagram 8

Secure the display console.

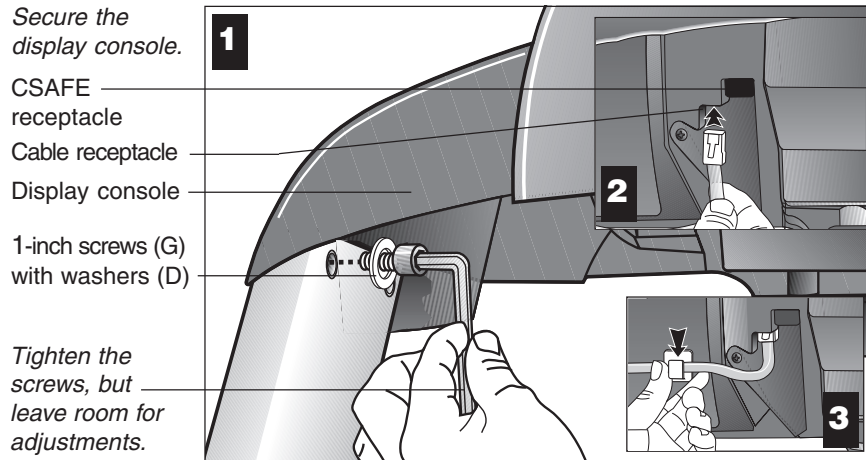

- b. Align the display console with the upright support mounts. Insert two 1-inch screws (G) with washers (D) and finger tighten. Do the same for the opposite upright support. Do not fully tighten the screws. Refer to Diagram 8, #1.
- c. Attach the cable connector by sliding it into its receptacle underneath the console. A definite “click” is heard when the cable is properly attached. Refer to Diagram 8, #2. If you do not hear and feel the connector “snap” into place, reinsert it.

Important: Do not use the receptacle covered by the plastic plug. This CSAFE receptacle is for a separate option.
- d. So that the cable does not hang below the console, slide it into the clip found underneath the console. Refer to Diagram 8, #3.

Diagram 9

Raise the incline.

Side rail
Incline lift

QUICKSTART™
key

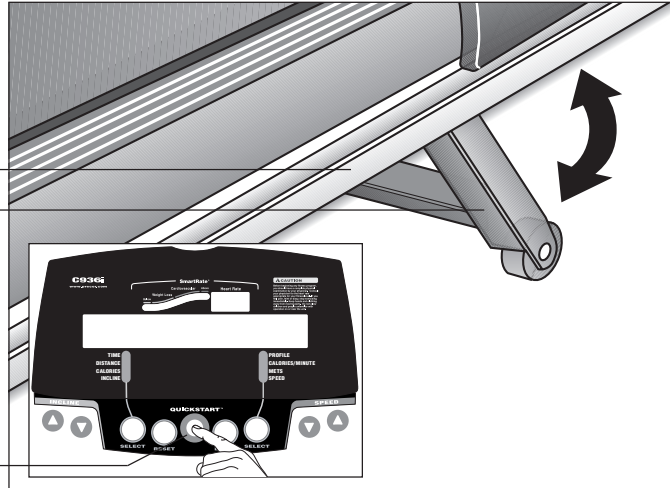

Important: With the handrails attached, the width of the treadmill is 33½ inches (85 cm). It will not fit through a standard 32-inch doorway.

10. **Prepare the unit for handrail installation.** Diagram 9. For an easier installation, raise the incline to its maximum height by taking the following steps:
 - a. Plug the treadmill into a power outlet and turn the unit ON.
 - b. Stand to the side of the treadmill and press QUICKSTART (see inset). After a few seconds, the running belt begins moving.
 - c. Press the INCLINE ▲ key until the display shows an incline of 15 percent.
 - d. Once the lift stops moving and the display indicates 15 percent, press the Stop (red) button and turn power switch OFF.

Diagram 10

Remove the lower handrail clamp.

Lower handrail clamp

Loosen and remove the four handrail clamp screws.

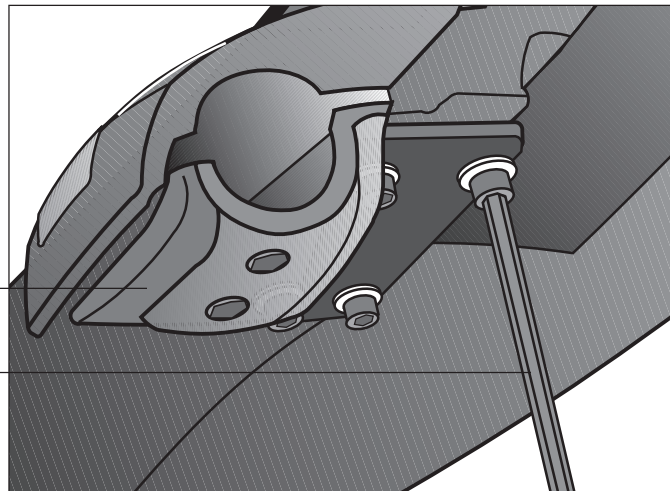

11. **Remove the lower handrail clamp.** Diagram 10. To prepare the unit for handrail installation, remove the four fasteners securing the lower handrail clamp. Use the hex key provided.

Diagram 11

Secure the handrails.

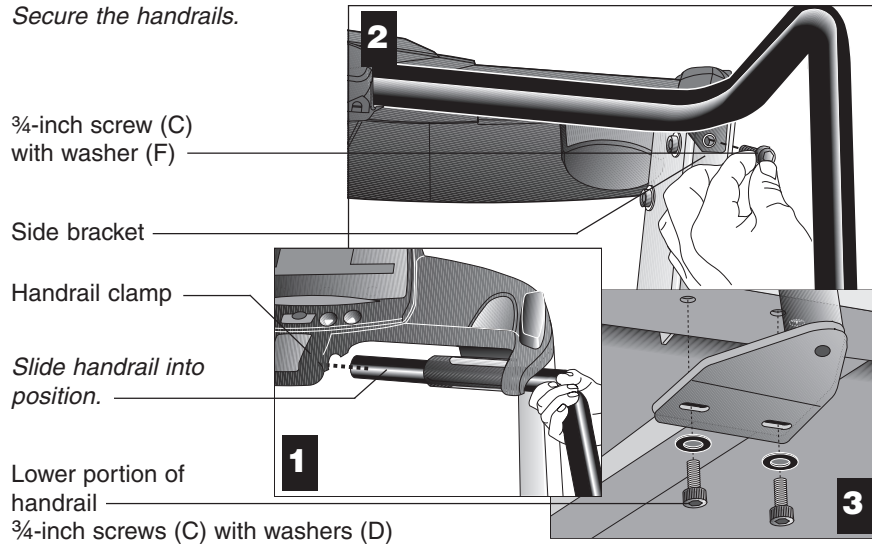

12. Attach handrails to the side and base brackets. Diagram 11.

Important: Attach one handrail at a time. Take the following steps on one side of the treadmill and then, attach the opposite handrail.

- a. Slide the end of the handrail toward the handrail clamp. Ask your assistant to hold the handrail in place while you insert screw (C) with washer (F). Finger tighten the screw to secure the handrail to the side bracket. See Diagram 11, #1 and #2.
- b. Attach the lower portion of the handrail. Diagram 11, #3. Align the handrail bracket with the two base mounting holes in the side rail. Place a washer (D) onto each of two screws (C) and insert the screws. Finger tighten.
- c. Perform steps a. and b. on the opposite side.

Diagram 12

Connect the heart rate cables.

Display console
Left handrail
Heart rate cable connections (male connector, female receptacle and vice versa for the opposite cable)
Security clip

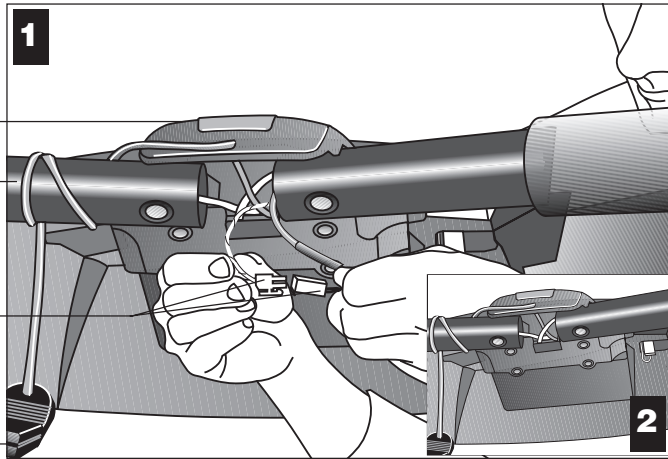

13. **Connect the heart rate cables.** Diagram 12. Cables protrude from the ends of both handrails and connect the metal strips on the handrails to the receiver inside the display. Once the cables are properly connected, a user's heart rate appears when the user grasps both touch-sensitive grips.

Important: Attach one cable at a time. The cable receptacles mirror the connectors so that they cannot be improperly installed. Do not force a connection! Take time to look for the appropriate cable receptacle. Perform the following steps, one cable connection at a time.

- a. Slide the end of the cable into its receptacle. Diagram 12, #1.
- b. Place the excess cable inside the display opening. Diagram 12, #2.
- c. Move to the opposite handrail and complete steps a and b.

Diagram 13

Test the heart rate feature.

Heart rate grips
Display console
Heart rate blinking indicator

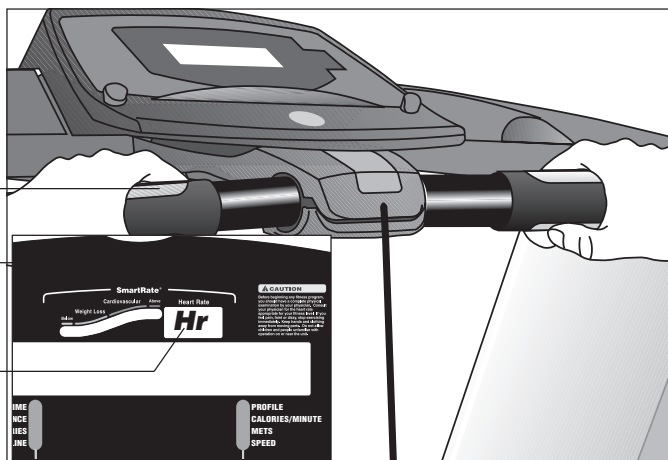

14. **Test the heart rate feature.** Diagram 13.

- a. Turn the unit ON. The Precor banner should appear in the display.
- b. Face the display and straddle the running belt.

- c. Place your left hand on the left handrail's heart rate grip and place your right hand on the right handrail grip. The letters "Hr" begin to blink in the upper right display indicating that a signal is being transmitted. Within about 15 seconds a heart rate appears.

Note: If the blinking "Hr" does not appear, turn the unit OFF. Recheck the cable connections and ask someone else to try the test (steps a through c).

- d. When the test is satisfactorily completed, turn OFF the treadmill and continue with the assembly.

Diagram 14

Install handrail clamp fasteners.

Hand held heart rate grip

Lower handrail clamp

Replace the four fasteners removed in step 11.

Washer (F)

1¼-inch screw (E)

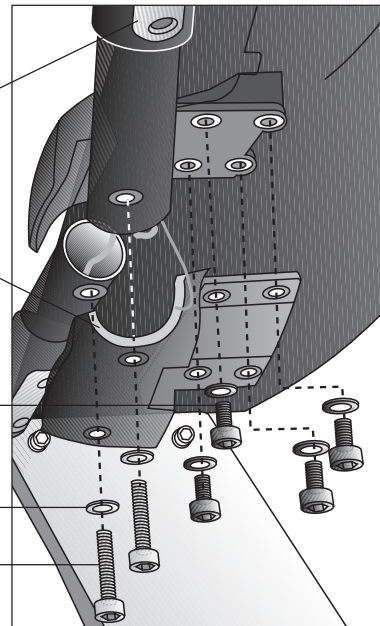

15. **Replace the lower handrail clamp.** Diagram 14. Replace the lower handrail clamp and the four fasteners removed in step 11. Make sure the top of the handrail is aligned with the top portion of the clamp. Turn all four fasteners until they are finger tight.
16. **Secure the handrails.** Diagram 14. Place a large washer (F) onto each of two screws (E). Thread the screws through the lower handrail clamp and finger tighten.

Diagram 15

Secure the fasteners.

Second:
Alternately tighten four side upright screws.

First: *Alternately tighten four front panel screws.*

Third: *Alternately tighten the four screws that secure the console to the uprights.*

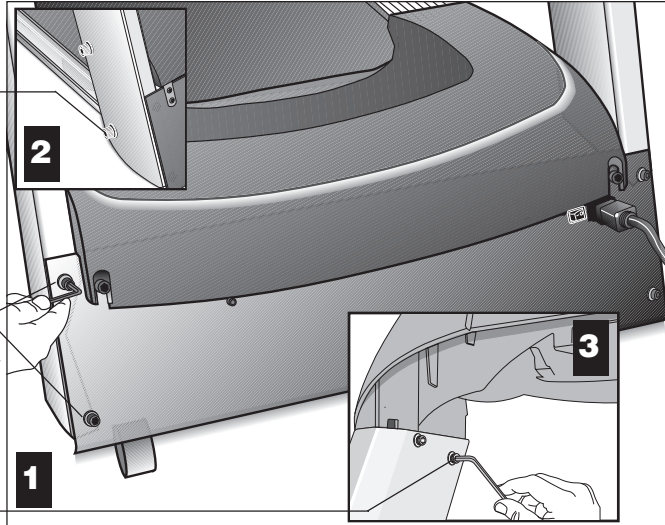

17. **Tighten all mounting screws with the hex key (H) provided.** Diagram 15. Start at the front of the treadmill with the four screws that attach the upright supports to the front panel. See Diagram 15, #1. Tightening these screws first helps pull the rest of the treadmill's parts into alignment. Second, proceed with tightening the four screws (A) that secure the upright supports. See Diagram 15, #2. Third, tighten the four console assembly screws (C). See Diagram 3, #3.

Important: *For proper alignment, it is critical that the fasteners are tightened in the order shown in Diagrams 15 and 16.*

Diagram 16

Tighten the handrail fasteners.

First: *Tighten the handrail clamp screws.*

Second:
Tighten the side bracket screws.

Third: *Tighten the lower handrail screws.*

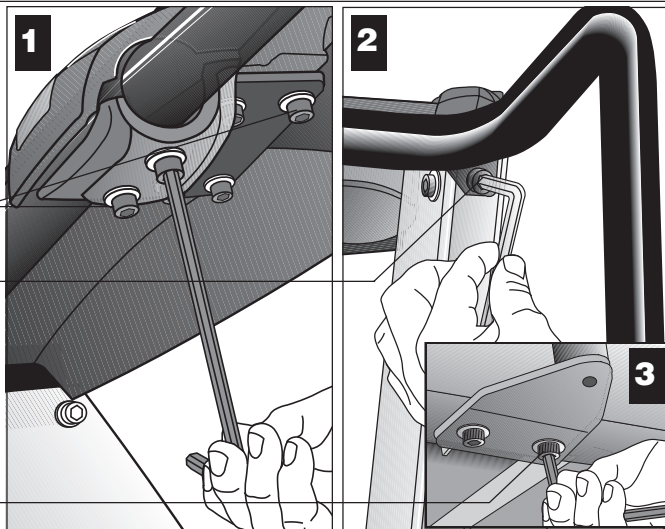

18. **Tighten all the handrail mounting screws.** Diagram 16. So that you don't overtighten the fasteners, hold the supplied hex key by its 3-inch section and tighten all six handrail clamp screws. See Diagram 16, #1. Next, tighten the two side bracket screws. Because of inaccessibility, hold the 10-inch section of the hex key to tighten the four lower handrail screws.

Diagram 17

Level
the
unit.

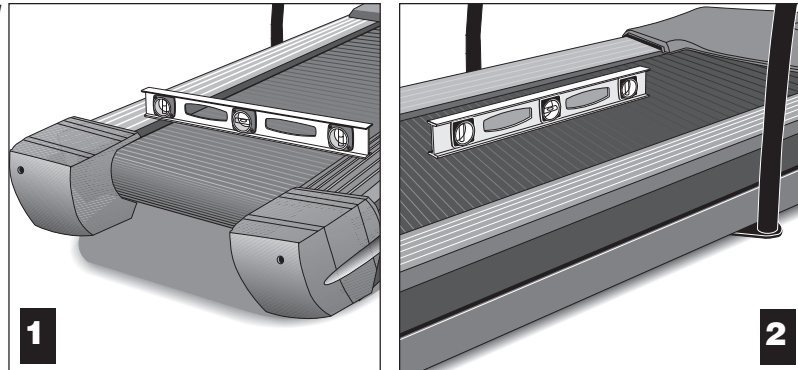

19. **Lower the treadmill incline.** Make the treadmill's running bed level by returning the incline to zero. To do this, you need to take the following steps:
 - a. Turn the unit ON.
 - b. Stand to the side of the unit and press QUICKSTART. After a few seconds, the running belt begins moving.
 - c. When the lift stops moving, press the red STOP button and turn the power switch OFF.
20. **Level the unit.** Diagram 17. The C936i has adjustable rear feet. Check to make sure that the running surface is level (use a bubble level as shown in Diagram 17). If the treadmill is placed on a slightly, uneven surface, adjusting the rear feet can help, but will not compensate for extremely uneven surfaces.

Important: If you need to make adjustments, adjust one rear foot at a time. **Do not** use the rear foot to raise or lower the unit more than $\frac{3}{4}$ -inches. Check the level of the unit after each adjustment.

Diagram 18 *Adjust the rear deck.*

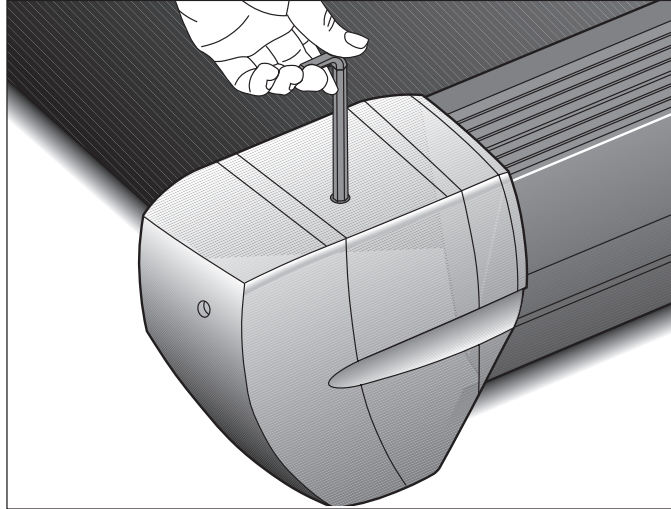

21. **Adjust the rear deck.** Diagram 18. To raise the rear deck, insert the ¼-inch hex key (H). Make sure that the key is fully engaged and turn it clockwise. Turning the hex key counterclockwise lowers the unit.
22. **Plug the power cord into an appropriate power outlet.** Refer to *Grounding Instructions* on page 3. Make sure that the ON/OFF (I/O) power switch, located on the front panel of the treadmill, is placed in the OFF (O) position before connecting to a power source.

CAUTION: The treadmill requires a dedicated, grounded circuit. A 20 amp dedicated circuit is recommended. Make sure that no other product or machine uses the same circuit as the treadmill.

TURNING THE UNIT ON AND OFF

Use the ON/OFF (I/O) power switch to turn the unit ON and OFF. This switch is located on the front of the unit, near the power cord.

To complete the installation of the treadmill, continue with *Checking the Alignment of the Running Belt*.

CHECKING THE ALIGNMENT OF THE RUNNING BELT

The belt is aligned at the factory before shipment. However, during shipment or by using the treadmill on an uneven surface, the belt might move off center. Proper belt alignment is important because it allows the belt to remain centered and assures smooth operation.

Follow these steps to check the alignment:

1. The treadmill has adjustable rear feet. Check to make sure that the running surface is level (refer to steps 19 and 20 on page 20).
2. Locate the I/O switch at the front of the treadmill and turn the unit ON.
3. Stand beside the treadmill and press QUICKSTART. The running belt starts automatically after the message, "**Belt Starting 3, 2, 1,...**" appears.
4. Continue standing next to the treadmill and hold down the Speed ▲ key until the display shows a speed of 3 miles per hour (5 kph).
5. Walk around to the rear of the unit and observe the belt for a few minutes as it moves.

If the running belt,...	Then,...
tracks centered on the running surface	the belt is functioning correctly. It is evenly distributed between the side rails so no adjustment is necessary.
runs or drifts off center	you need to adjust the belt; see <i>Aligning the Running Belt</i> , page 47.

Important: *If you notice that the belt needs alignment, make the adjustments at once. Failure to do so might cause the belt to tear or fray which is not covered by the Precor Limited Warranty.*

6. To stop the running belt, press the red STOP button.

If the belt is functioning correctly, the treadmill is ready to use. Please continue on to *Club Information* to learn how to customize the treadmill for your Club.

Club Information

These next few pages provide information that lets you customize the treadmill for your Club. It is not information that your customer needs or, necessarily, should see. This section covers the following information about how to:

- select the unit of measure: U.S. standard or Metric
- set maximum speed, workout, and pause times
- display the odometer and other useful information
- connect to CSAFE compatible devices

Note: If your customers are interested in the learning more about the C936i treadmill, you may wish to direct them to the manual available on Precor's web site (www.precor.com). (The manual that appears on the web site does not contain the information found in this section.)

Diagram 19 *Display console keypad.*

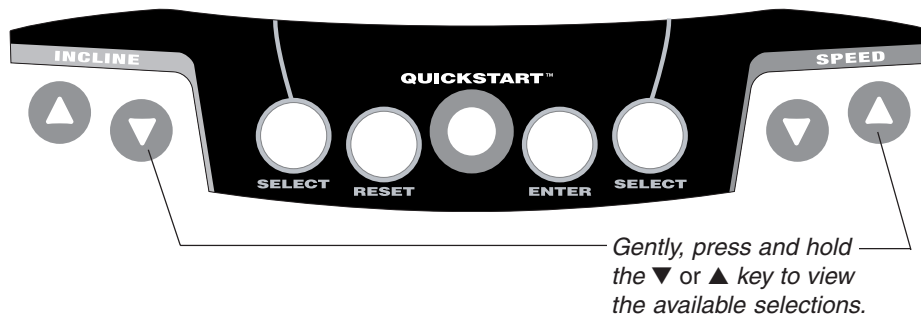

CHANGING THE CLUB SETTINGS

The Club “custom” settings are accessed through specific codes that help eliminate unauthorized access. Refer to Diagram 19 to locate the keys. Information that you can access and features that can be customized are as follows:

- **Units of Measure** — Select between U.S. Standard and Metric displays.
- **Maximum Speed** — Determines the maximum speed that a user can select. Selections range between 0.5 to 11 mph (1 - 18 kph).
- **Maximum Workout Time** — Sets a maximum limit on workout time.

Note: Remember that the user will get an additional five-minute cool down period appended to a completed program. So, adjust the maximum time limit accordingly.

- **Maximum Pause Time** — Sets the maximum duration in which a person can “pause” his or her workout.
- **Odometer, Hours of Use, Software Version, and Error Log** —The treadmill stores the cumulative miles or kilometers, the number of hours that the unit has been in use, the software version and software type (which is valuable when calling Customer Support), and an error log (useful when troubleshooting).

To access the Club settings, the following must occur:

- Check to be sure that the treadmill is turned ON.**
- Check that the Precor banner appears on the display.**
- Press the appropriate key sequences.** (To cancel entries, press RESET.)

The display console keys that you need to press to select the units of measure or set the maximum speed, workout, and pause times are as follows:

Stop, QUICKSTART, ENTER, QUICKSTART, INCLINE ▲, QUICKSTART, ENTER, QUICKSTART

Note: To initiate the Club Custom mode, you need to press QUICKSTART within 1/3 second after pressing the Stop button. (The RESET key may be used in place of the Stop button.)

Important: To access Club Custom mode, press Stop while the Precor banner is displayed. Within 1/3 second, begin pressing the key sequences. If the system does not detect a key press (within 1/3 second) after Stop, it resets to the Precor banner. When you begin entering a key sequence, each key must be pressed within four seconds of the other or the Precor banner reappears and you have to begin again.

Display key functions within the Club Custom Mode	
▼▲ lets you scroll through the various selections that appear. The longer the key is held down, the faster the numbers scroll past.	SELECT reminds you what part of the program you're changing.
Stop advances to the next aspect of the program without storing the information that appears on the display.	RESET exits Club Custom mode and displays the Precor banner.
	ENTER saves the information being displayed and moves to the next aspect of the program.

DETERMINING THE UNITS OF MEASURE

Two different units of measure can be selected, *Metric* or *U.S. standard*. Make your selection using the ▼▲ keys. Press ENTER once the correct unit is displayed.

Note: Anytime you wish to exit the Club Custom mode, press the RESET key. The display attributes that you selected by pressing ENTER are saved and recorded in memory.

CAUTION: If you change the Unit of Measure display, be sure to check the “Set Max Speed” setting to verify that it is correct. Refer to *Determining the Club Speed Limit*.

DETERMINING THE CLUB SPEED LIMIT

You can set the maximum speed for the treadmill. This limits how fast the running belt moves and, consequently, how many adjustments a user can make to the treadmill's speed. The speed is displayed in miles per hour (mph) or kilometers per hour (kph) depending upon the units of measure (Metric or U.S. standard) that are selected.

The ▼▲ keys let you choose a speed between: **0.5 to 11.0 mph**
1 to 18 kph

Important: If you select a number that limits the miles per hour, your change will not affect the kilometers per hour (and vice versa). The treadmill does not convert the speed entered in miles per hour (U.S. standard) to kilometers per hour (Metric). It stores separate numbers for the different units of measure.

SETTING A WORKOUT TIME LIMIT

You can limit how long a user works out by setting a duration between 1 and 240 minutes. The treadmill also lets you choose "INFINITE" (found at the zero point between 240 and 1) which allows the user to select a program and work out indefinitely.

Note: The QuickStart program is automatically limited to the Club limit. However, if a user presses QUICKSTART at the Precor banner, and the Club program has limited workout time to less than 30 minutes, then that duration takes effect. For example, if you set the workout time limit to 20 minutes, the treadmill allows users to specify a workout between 1 and 20 minutes. Users cannot specify a time longer than 20 minutes.

Important: Exceptions to the rule above include the Cross Country program (set at 30 minutes) and the Weight Loss program (set at 28 minutes).

Use the ▼▲ keys to select a workout time limit. Touch either ▼▲ key and the display changes in one minute increments. Press and hold the ▼ or ▲ key and the numbers advance or decrease faster. Take into account that the user may get an additional five-minute cool down period appended to his or her workout (depending on program selection), so adjust the maximum time limit accordingly.

Note: If the workout time is set to INFINITE, users can workout indefinitely, so no cool-down period is appended to the program selection.

SETTING A PAUSE TIME LIMIT

Setting a Pause time limit is useful because the treadmill returns to the Precor banner at a selected interval after the Stop key is pressed whether the user planned to return or not.

Use the ▼▲ keys to set a Pause time limit between 1 and 120 seconds (two minutes).

VIEWING THE ODOMETER, HOURS OF USE, SOFTWARE VERSION, ERROR LOG AND SERIAL NUMBER

While the Precor banner is being displayed, press:

Stop, ENTER, QUICKSTART

Note: You need to press ENTER within 1/3 second after pressing the Stop button to initiate the Club Custom mode. (The RESET key may be used in place of the Stop button.)

The field name Odometer appears briefly and then the odometer value (the cumulative miles or kilometers users have travelled) appears. When either Select key is pressed the word "MILES" (or "KILOMETERS") appears on the display to let you know the unit of measure. When the key is released, the odometer value reappears.

Press ENTER and the number of hours (Hour Meter) that the unit has been in use appears. The C936i notes the passing of minutes, but the numeric value that appears is truncated to the nearest full hour. When either SELECT key is pressed the word "HOURS" appears on the display. When the key is released, the hour meter reappears.

Press ENTER and the unit's three digit SW Version (upper display software version number) appears. Press either SELECT key to view the lower board's software version number. The SELECT key toggles between the two versions. The words "UPPER" and "LOWER" appear prior to the version being displayed.

Press ENTER or the red STOP button and the Error Log appears. Press any ▼ or ▲ key to scroll through the error codes. Up to ten error codes can be recorded and retrieved.

To view the odometer reading at the time the error was detected and the hours of use at the time the error occurred, press either SELECT key while the error code is being displayed. The SELECT keys act as toggles between the associated information.

Note: To clear (delete) the error log, press QUICKSTART for at least four seconds while viewing the list. Prompts appear on the display and let you know when the error messages have been deleted ("cleared" from memory).

Important: *You cannot retrieve the error log once you have deleted it.*

To view the serial number, press ENTER. Write the serial number onto the warranty registration form on page 50 and in the space provided on page 7. The serial number is helpful should you ever need to contact Customer Support.

To return to the Precor banner, press RESET, ENTER or the red STOP button.

USING CSAFE STANDARD EQUIPMENT

The C936i is fully compatible with CSAFE protocols. If the unit is connected to a CSAFE master device, the user will be prompted to enter a user ID. Five zeros appear on the display. The left zero blinks to indicate that it is awaiting input. The following table provides information about the keypad functions:

User ID Entry:	Program Keys
INCLINE ▼ or ▲	moves the blinking LED from field to field.
SPEED ▲ or ▼	changes the number value in the selected field.
ENTER	submits the displayed user ID. Note that if the 5 zeros are being displayed when the user presses ENTER, user ID entry is bypassed and the program prompt appears.
RESET	resets the display to the Precor banner.

A message indicates when the user ID is accepted by the CSAFE master device. Then, the program prompt is displayed. See *Quick Steps to Working Out* on page 37.

To review information about CSAFE specifications, visit the web site at:

www.fitlinxx.com/csafe

Additional CSAFE commands supported by the C936i software include:

SetProgram, SerUserInfo, GetUserInfo, GetOdometer, and GetErrorCode

The C936i Display

The C936i is designed so users can work out with minimal instruction or training. The directions on the console and the prompts on the display will guide a user through the entire workout session. Before the treadmill is used, however, we recommend that you, as club owner or manager, familiarize yourself with it so you can instruct your customers to use it safely and effectively.

This section covers the following information:

- an overview of the features provided on the display console
- an explanation about the available programs
- instructions for utilizing the heart rate options

FEATURES ON THE DISPLAY CONSOLE

As a user works out, indicator lights appear next to the feature being displayed. When a user begins a program, the display initially presents TIME and PROFILE. The user can change what features appear by pressing the SELECT keys. Refer to *Changing the Display Features Using the SELECT Key* on page 35.

Diagram 20 C936i Display Console

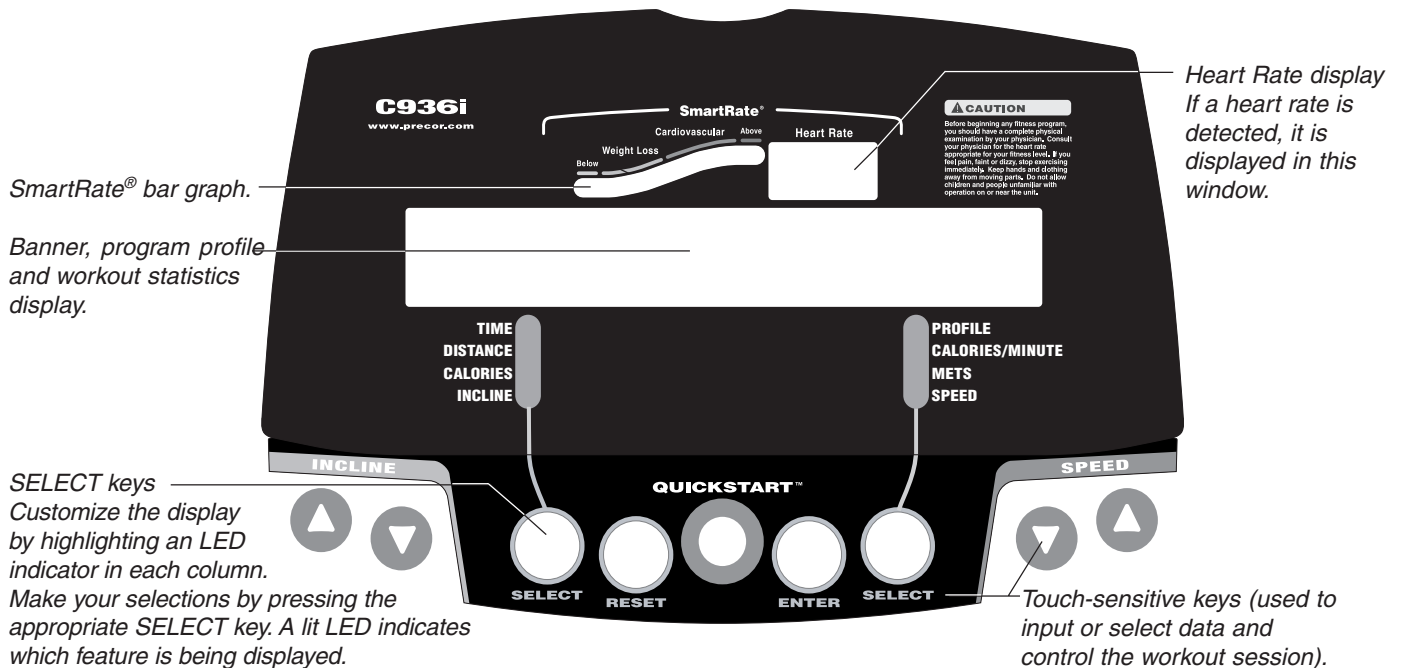

During a workout, the display console provides motivation by presenting constant feedback about a user's progress. A brief explanation of each feature on the display console appears in Diagram 20. Look on the next pages for a more thorough explanation.

Note: If an error message appears, call a Precor qualified service technician or service center. Refer to *Obtaining Service* on page 7.

SMARTRATE® DISPLAY

A user must enter an AGE (during the program Setup prompts) and wear a chest strap, while in a program, before the blinking segment in the bar graph can show the zone that his or her heart rate is in, either: Weight Loss or Cardiovascular.

Weight Loss Zone: Maintaining the heart rate between 55% and 70% of the user's maximum aerobic heart rate, helps burn enough calories that, when continued on a regular basis for 30 minutes or more, provides the greatest fat-burning results.

Cardiovascular Zone: Maintaining the heart rate between 70% and 85% of the user's maximum aerobic heart rate, helps (when continued on a regular basis for 30 minutes or more) improve the user's overall cardiovascular/ cardiorespiratory fitness level.

Important: *During a program, a user's heart rate must be above 40 beats per minute before the segment begins to blink. Note that pressing QUICKSTART, at the Precor banner display, disables the SmartRate® display feature.*

HEART RATE: The heart rate display lets the user monitor their heart rate. When a heart beat is detected, the number appears in the small upper right display (refer to Diagram 20). If the user does not grasp the grips on the handrail or wear the optional chest strap, a heart rate will not be detected and no pulse rate appears.

SETUP MODE AND PROMPTS

From the Precor banner, a user accesses the Setup mode which lets him or her "set" the program, workout time, weight, and age parameters prior to working out.

The Precor banner is the "starting point" to begin a workout. It indicates that the C936i is ready to accept user entries. If the banner does not appear on the display, press the RESET key. If the display appears blank, make sure that the treadmill is turned ON.

Note: Key presses to the INCLINE ▼▲ or SPEED ▼▲ keys are ignored when the banner is being displayed. Refer to page 33 for more information about the keypad.

PROGRAM: The abbreviated program name and profile appears on the display. The ▼ and ▲ keys allow the user to scroll through the available programs. The left portion of the display presents the abbreviated name of the program, while the right half displays the program profile. The text blinks indicating that it is awaiting approval. To choose the selection being displayed and continue in Setup mode, press **Enter**. (Refer to *The Setup Mode and the QuickStart Feature* on page 30.)

Note: Depending on the program that is selected, the user may be prompted for other information. Refer to *Programs* on page 41.

TIME: Acceptable entries range between INFINITE and 240 minutes. (See “Note” below.) The display blinks to indicate that it is awaiting a selection. Use the ▼ and ▲ keys to change the selection. To continue in Setup mode, press ENTER.

Note: The Club manager has the ability to set a time limit on the length of a workout. Refer to *Club Information* on page 23. (The Weight Loss and Cross Country programs have a preset time limit so a WORKOUT TIME prompt does not occur when a user chooses WTLS or XCTR.)

WEIGHT: Acceptable entries range from 1 through 999 (pounds or kilograms). A user can change the blinking number using the ▼ and ▲ keys or accept the displayed number (and continue in Setup mode) by pressing ENTER.

Important: A number that reflects the user’s actual weight must be entered since the calorie count and several other calculations are based on the weight entry.

AGE: Acceptable entries range from 1 to 99. Change the blinking number using the ▼ and ▲ keys or accept the displayed number by pressing ENTER. Initially, the number zero appears on the display. Once the ▲ key is pressed the number jumps to 35.

Important: An age entry is required if a user wants to use the heart rate interactive capabilities of the treadmill. Refer to *QUICKSTART* on page 34.

THE SETUP MODE AND THE QUICKSTART FEATURE

The QuickStart feature can be pressed any time during the Setup prompts. See the table below.

Note: Default values apply if QUICKSTART is pressed while the Precor banner is displayed. Refer to *QUICKSTART* on page 34.

Press QUICKSTART at	The following occurs:
Precor banner	Bypass the remaining Setup prompts and the running belt begins moving after a three second countdown. The Manual program appears and default values apply.
Program prompt	The profile associated with the program appears on the right side of the display.
TIME prompt	The information that appears on the display becomes the work-out time for the program. A user can change the display using the ▼ or ▲ keys. Refer to <i>Club Information</i> on page 23.
WEIGHT prompt	The weight (1 through 999) that appears on the display becomes the user’s designated weight that the C936i uses to compute various calculations.

Press QUICKSTART at

The following occurs:

AGE prompt

The age (1 through 99) that appears on the display becomes the designated age that the C936i uses for SmartRate®. A correct age entry between 1 and 99 is very important if the user plans to utilize the heart rate characteristics of the treadmill. The QUICKSTART key acts the same as the ENTER key at this point because all the Setup prompts have been answered.

DISPLAY FEATURES DURING A WORKOUT

Note: The Setup prompts that appear in this display prior to a workout need to be addressed using the keypad keys. Refer to *Setup Mode and Prompts* on page 29.

During workouts, the program profile that appears in the display corresponds to the selected program. The blinking column in the program profile indicates the incline level and user's progress along the program.

Once the running belt begins moving, indicator lights appear in the columns below the display and indicate which information is being displayed. A user can highlight a particular feature by pressing the appropriate SELECT key.

The following describes the information that can appear in the display.

TIME: As a user works out, TIME indicates the amount of time spent in his or her work out. The time (00:00) display appears when the workout begins. Time appears in minutes and seconds. However, should a user exceed 60 minutes (during a single workout), the Time display converts to hours and minutes. When QUICKSTART is pressed at the banner or INFINITE is available and is selected during the Setup prompts, the Time display shows how long a user has been working out. However, in warm-up and cool-down periods, and in all other programs, the Time display indicates the minutes remaining.

Important: A user's "pace" (time per mile or kilometer) can also be displayed in the TIME field. Refer to the SPEED keys on page 34.

DISTANCE: The distance travelled appears (0.00) once a user begins a program. The distance can appear in miles or kilometers. Note that if the distance exceeds 65 miles (km) in a single workout, the display resets to zero. To change which units of measure appear on the display, the club owner or manager can follow the instructions found in *Club Information* on page 23.

CALORIES: Provides the cumulative number of calories being burned by the user.

INCLINE: Displays the selected percent of incline during a workout. The INCLINE ▲ and ▼ keys affect the treadmill's lift and let the user set an incline between 0 percent and 15 percent. The displayed values change in 0.5 percent increments. Refer to INCLINE ▲▼ keys on page 33.

When the INCLINE field is selected and the target incline changes, the target incline continues to be displayed as the lift moves to the new incline level. A few seconds after the lift reaches the requested incline, the display no longer appears.

Note: To check the incline (when it is not the chosen display) any time during a workout, lightly press either INCLINE ▲ or ▼ key for less than two seconds. If a user presses the INCLINE ▲ or ▼ key for more than two seconds, the treadmill's incline will change.

PROFILE: At the beginning of a program, the profile appears on the right side of the display and corresponds to the program that the user selected. As the user proceeds through his or her workout, the position in the program is indicated by a blinking column. The height of the column indicates the level of incline. Every time the incline changes by several sequential levels (up or down) the height of the column changes by one cell.

CALORIES PER MINUTE: Indicates the approximate number of calories being burned per minute.

METS: Displays the metabolic equivalents associated with a user's current energy expenditure level. A METS level of 1 represents the body at rest. Note that when the running belt stops moving, the METS value displays zero.

SPEED: Displays the running belt's speed. The running belt speed ranges from 0.5 to 11 mph (1 to 18 kph), but a maximum speed can be set by the club (see *Club Information* on page 23). The SPEED ▼▲ keys let a user decrease or increase the running belt's speed in 0.1 increments.

Important: To check the speed (when it is not the chosen display) any time during a workout, the user can lightly press either SPEED ▼ or ▲ key (for less than two seconds). The running belt's speed appears in the right portion of the display. If a user presses the SPEED ▼ or ▲ key for more than two seconds, the treadmill's speed will change.

PACE: Displays the user's target speed in minutes and seconds per mile (or kilometer). The user's pace appears in the TIME field when the SPEED indicator is **not** lit and the user taps the SPEED ▼ or ▲ key.

Diagram 21 *Display console keypad.*

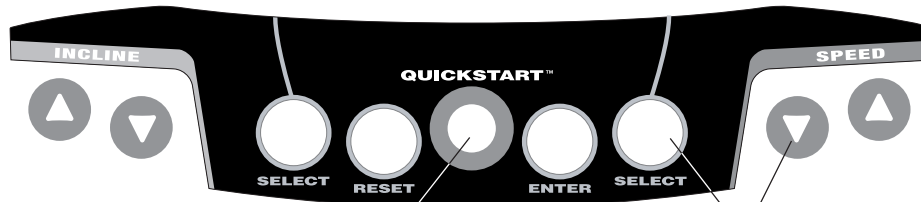

QUICKSTART: When pressed at the Precor banner, the running belt begins moving after a three second delay. SmartRate® is inactive and default values apply.

Keypad keys

The keypad keys let the user:

- control your workout session,
- answer prompts prior to starting a program,
- determine which display features appear,
- prematurely end a program, and
- adjust the incline and speed levels.

KEYS ON THE DISPLAY CONSOLE

The following information explains the different uses of the keys on the keypad. To locate each key, look at the display console or refer to Diagram 21.

INCLINE ▲▼: During a workout, the INCLINE ▲▼ keys let the user increase or decrease the incline in 0.5 percent increments. The display can show a range from 0 percent to 15 percent.

When a user changes the incline by pressing the INCLINE ▲ or ▼ key, the number that appears on the display shows the *target* incline (not necessarily, the present incline) because the display can change much faster than the treadmill's lift.

Note: Anytime during a workout, the user can view the actual incline by lightly touching either INCLINE ▲ or ▼ key. The percent of incline appears on the left of the display. To change the incline, the user must hold the key down for more than two seconds.

During Setup mode, the INCLINE ▲▼ keys are used for data selection. Pressing either ▲ or ▼ key does not affect the incline. However the ▲ or ▼ keys do affect what appears on the display. Refer to *Setup Mode and Prompts* on page 29.

SELECT keys: During a program, the SELECT keys change what items appear on the display. Refer to *Changing the Display Features Using the Select Key* on page 35.

RESET: Provides access to diagnostics (see *Club Information* on page 23) and lets the user access the WORKOUT SUMMARY display while in Pause mode. If the user presses RESET again, he or she exits the WORKOUT SUMMARY and returns to the Precor banner. Note that if the user presses RESET during the Setup mode, he or she returns to the Precor banner.

QUICKSTART: This key lets the user bypass the Setup prompts and start working out immediately using the Manual program. **Default values apply.**

QUICKSTART Default Values	
Prompts	Default Value
PROGRAM	Manual
TIME	Club dependent (usually 30 minutes - see page 25.)
WEIGHT	150 lbs. (68 kg.)
AGE	0 : A valid AGE must be entered to utilize the SmartRate® display. If QUICKSTART is pressed after an AGE is entered, then the SmartRate display will appear when a user wears the chest strap or grasps the touch-sensitive handrail grips. If no AGE entry occurs, then SmartRate LED's light, but are not activated. Note that the chest strap is available through a Precor dealer. Refer to <i>Obtaining Service</i> on page 7.

The QUICKSTART key can be pressed any time during the Setup prompts. For more information, refer to page 30, *The Setup Mode and the QuickStart Feature*.

ENTER: Workout specific prompts which appear on the display need to be addressed and then “entered” into the unit's memory by pressing the ENTER key. Refer to *Quick Steps to Working Out* on page 37.

SPEED ▼▲: During a workout, the SPEED keys let the user decrease or increase the running belt's speed. The display can show a range from 0.5 to 11 miles per hour (1 to 18 kilometers per hour) and changes can be made in 0.1 increments from 1 to 11 mph (1 to 18 kph). The display indicates a speed of “0” when a user presses the SPEED ▼ key to stop the running belt.

Any time during a workout, the user can view the actual speed by lightly tapping either SPEED ▼ or ▲ key. His or her “pace” (minutes per mile or kilometer) appears in the left-most portion of the display. To change the speed, a user can hold the key down for more than two seconds.

During Setup mode, the SPEED ▼▲ keys are used for data selection. Pressing either ▼ or ▲ key changes what appears on the display, but does not affect the speed of the running belt. Refer to *Setup Mode and Prompts* on page 29.

CHANGING THE DISPLAY FEATURES USING THE SELECT KEY

The SELECT keys let the user choose which features appear on the display. When a user enters a program, the TIME and PROFILE features are preselected.

Each SELECT key affects four different display features. The left SELECT key, causes the indicator light to appear next to TIME, DISTANCE, CALORIES, and INCLINE. The right SELECT key, highlights PROFILE, CALORIES/MINUTE, METS, and SPEED.

A user determines which features appear by pressing the SELECT keys to switch the indicator lights, next to the item, on or off. If the indicator light is off, the item will not appear in the display.

Exercising on the Treadmill

Once the C936i is set up, it is ready to use. There are no complex instructions to follow or mandatory programming steps required to operate the treadmill. The easy-to-understand prompts let the user select a program and specify how long he or she wishes to work out. The speed and incline levels can be adapted to meet fitness goals.

Important: Club owners, managers, personal trainers. Remind users how important it is to use the treadmill's safety features and security clip while working out on the treadmill. Instruct them on how to attach it to their clothing near their waistline. If any complications occur, a strong tug on the security cord or a quick tap on the red STOP button will stop the running belt.

Note: This section of the manual is written for the user because it specifically explains how to work out on the treadmill. References are made in second person.

Information presented in this section includes:

- Using the safety features
- Quick steps to working out
- Reviewing keypad and workout tips
- Cooling down, pause and exiting features

CAUTION: Do not allow children on or near the treadmill. If anything should get caught in the rollers, the running belt does not stop immediately.

USING THE SECURITY CLIP

A security clip is attached by its cord to the red STOP button that straddles the handrail. **Always attach the security clip to your clothing before each workout.** A tug on the cord trips the security switch and slows the running belt to a stop. If the security switch trips while you are working out, the treadmill retains your workout statistics and enters Pause mode. To resume your workout, reattach the security clip to your clothing, and press the SPEED ▲ key until you reach the desired speed.

Important: Club owners, managers, personal trainers. Remind users how important it is to use the security clip while working out on the treadmill. Instruct them on how to attach it to their clothing near their waistline. If any complications occur, a strong tug on the security cord will stop the running belt.

USING THE HANDRAILS

Always grasp the handrails to keep your balance when stepping on to or off of the treadmill. Hold onto one handrail when touching the keypad with the other.

USING THE HEART RATE “TOUCH” CAPABILITY

If a user wishes to view his or her heart rate on the display, instruct them to grasp the touch-sensitive strips (called “grips”) on the handrails while working out. A heart rate signal is transmitted to the receiver installed in the display console. During a workout, the heart rate indicator displays the heart rate. This lets the user see what his or her heart rate is doing even when the display is presenting other workout statistics.

KEYPAD TIPS

Important: The keys on the keypad are touch-sensitive. A light “touch” is all that is required to activate the key function. Key presses to the ▼ or ▲ key are ignored when the Precor banner is being displayed.

RESET — exits the Setup Mode or accesses the Workout Summary while in Pause mode.

QUICKSTART — bypasses further selections and starts the running belt. Default values apply (see QUICKSTART on page 34). SmartRate® is not active.

ENTER — initiates the Setup mode and allows you to enter display selections.

WORKOUT TIPS

- Always attach the security clip to your clothing prior to working out.
- Answer Setup prompts by pressing the ▼ or ▲ keys. (Incline and speed levels are not affected until the program begins.)
- Press ENTER to select the information being displayed.
- Accurate entries are required or features, such as SmartRate®, will not work properly.
- A time-out occurs during the Setup prompts if the C936i detects no key presses for two minutes. The display returns to the Precor banner.
- Anytime during setup process, press RESET to return to the Precor banner.

QUICK STEPS TO WORKING OUT

The steps to working out on the C936i are listed below. A short explanation appears on the left with the more thorough description following on the right.

CAUTION: Before beginning any fitness program, obtain a complete physical examination from your physician.

- | | |
|---|---|
| <p>1 ▶ Put on the chest strap.
(Available with the Precor Heart Rate Option.)</p> | <p>1. For your heart rate to appear on the display, you need to wear a chest strap or hold on to both touch-sensitive grips on the handrail.</p> |
| <p>2 ▶ Straddle belt.</p> | <p>2. Straddle the running belt with your feet firmly planted on the right and left staging platforms. (Stand close enough to the display console so that you can extend your arms to easily touch the keys.)</p> |
| <p>3 ▶ Attach security clip to clothing.</p> | <p>3. Attach the security clip to your clothing near your waistline where it will not interfere with your workout.</p> |

CAUTION: Hold onto the handrails if you press the QUICKSTART key. The running belt starts automatically.

- 4** ▶ **Select a program.**
4. To display the program selections, press ENTER and then, press any ▼ or ▲ key.
- Note:** You can begin your workout immediately from the Precor banner by pressing QUICKSTART. Default values apply. Refer to page 34.
- 5** ▶ **Begin working out.**
Enter the program selection, answer prompts, and enter your Weight and Age.
5. If you choose to continue the setup process, you are prompted to enter your WEIGHT and AGE. Follow the instructions on the display. When prompted, press SPEED ▲ with the one hand while you hold onto the handrail with the other. Step onto the running belt while the speed is at 1 mph (2 kph). Once you are comfortable with the walking or running speed, you can remove your hand(s) from the handrail.
- (Pause)
- To pause during your workout session before finishing the selected program, press the Stop key. See *Pause, Workout Summary and Exit Features* for more information.
- 6** ▶ **Continue your workout.**
 (Cool down)
6. When you have completed a program, a five-minute cool-down period automatically begins. Hold onto the handrail.
- Note:** Always incorporate a cool-down period into your workout. See *Cooling Down After Your Workout*.
- 7** ▶ **End your workout.**
 (Review WORKOUT SUMMARY)
7. After you complete the five-minute cool-down period, the running belt comes to a complete stop and a WORKOUT SUMMARY banner appears. Workout statistics except TIME, DISTANCE and CALORIES reset to zero. (Note that the TIME display shows the accumulated workout time including warm-up and cool-down periods.) You are given two minutes to review your workout statistics before the display automatically resets to the Precor banner. To return to the Precor banner, prior to the two minute time-out, press RESET.
- 8** ▶ **Remove the security clip and step off the treadmill.**
8. Detach the security clip from your clothing and carefully step down from the treadmill.

COOLING DOWN AFTER A WORKOUT

Cooling down is an important aspect of your workout because it helps reduce muscle stiffness and soreness by transporting excess lactic acid out of the working muscles. Cooling down for at least three minutes helps provide a smooth transition that allows your heart rate to return to its normal (non-exercising) state. The treadmill automatically initiates a five-minute cool-down period on several of its programs. A prompt appears, indicating that you are in cool down.

During your cool down, the workout statistics continue to appear. The Time display counts down so you know how much time remains. When you complete the five-minute cool down, a **WORKOUT SUMMARY** banner appears. See the information on page 40. The following information describes what happens when you press certain keys while in the cool-down mode.

While in Cool down, you press	This is what happens...,
-------------------------------	--------------------------

red STOP button	Enters Pause mode. The running belt slows to a gradual stop. TIME stops accruing. The display features remain, so you can review your workout statistics. Note that the Pause mode has a time limit and the club has the option to change the setting. If you enter Pause mode during your cool down, it is of limited duration.
------------------------	--

While in Cool down/Pause mode, you press	This is what happens...,
--	--------------------------

SPEED ▲	Starts the running belt moving again and returns to the cool-down period from where you left off. TIME continues to count down.
----------------	---

RESET	Displays the workout summary banner. See the information under Pause mode.
--------------	--

PAUSE, WORKOUT SUMMARY, AND EXIT FEATURES

Pausing and exiting are integral parts of your workout and can be accessed any time during a program.

Pause mode — can be accessed while in a program or during cool down. Note that the Pause mode has a time limit and the club has the option to change the setting. If you enter Pause mode during your cool down, it is of limited duration.

WORKOUT SUMMARY display — provides a two minute time frame in which you can review your workout statistics before the display automatically resets to the Precor banner. The WORKOUT SUMMARY banner can be accessed from the Pause or Cool Down/Pause modes, or by prematurely exiting a program. When you access the workout summary display, workout statistics except TIME, DISTANCE and CALORIES reset to zero. (Note that the TIME and CALORIES displays show the accumulated workout time and expended calories including warm-up and cool-down periods.)

The following information shows what happens when you press certain keys while in the various modes.

During a program, you press	This is what happens...
Stop	Enter Pause mode. The running belt slows to a gradual stop. Note that you may also press the SPEED ▼ key until the running belt stops. When the belt stops, TIME stops accruing. The display features remain, so you can review your workout statistics.
In Pause mode, you press	This is what happens...
SPEED ▲	Exits Pause mode and starts the running belt moving again so that you can resume where you left off.
RESET	Displays the WORKOUT SUMMARY banner so that you can view your workout statistics.
At the WORKOUT SUMMARY banner, you press	This is what happens...
RESET	Resets the display to the Precor banner.

Programs

The C936i lets the user choose between six programs. This section provides information about the special features and functions of the treadmill's programs and how to best utilize the:

- SmartRate® feature
- Cross Country program
- Weight Loss program
- Heart Rate program
- Manual program
- Interval program
- Random program

Note: To choose a program (other than Manual), begin at the Precor banner and press ENTER. User-friendly prompts guide the user through the program selections. Refer to *Quick Steps to Working Out* on page 37.

THE HEART RATE FEATURE

To use the heart rate features you must wear the chest strap while working out unless you are using the C936i with the touch-sensitive handrail grips. The chest strap transmits your heart rate signal to the receiver installed in the display console. The signal appears as a number in the heart rate display. This lets you monitor your heart rate even when the display is presenting other workout statistics.

USING THE SMARTRATE® FEATURE

Add the benefit of SmartRate® to every program on the treadmill. Using SmartRate® as a visual cue helps a user adjust their exercise routine to suit specific needs. SmartRate® simplifies the correlation between heart rate and exercise. A user doesn't have to stop concentrating on a workout to find a pulse. It is displayed right in front of them along with the SmartRate® zone. Once a user begins a workout, a blinking segment in the bar graph appears on the left of the display, if a user entered an age during the Setup prompts. The segment blinks in time with the user's pulse and highlights the zone that their heart rate is in: **Weight Loss** or **Cardiovascular**.

Important: Access to SmartRate® is only available when the person exercising wears a chest strap or uses the touch-sensitive grips on the handrails. (The chest strap is separate purchase option.) The SmartRate® indicator lights do not appear when QUICKSTART is used to select a program.

For the ideal "weight loss" range, a user's heart rate should be between 55% and 70% of his or her maximum aerobic heart rate. It should never exceed 85% of his or her maximum aerobic heart rate or go above the user's target zone. Refer to Diagram 22 for the appropriate target zone.

Diagram 22
Target Zones.

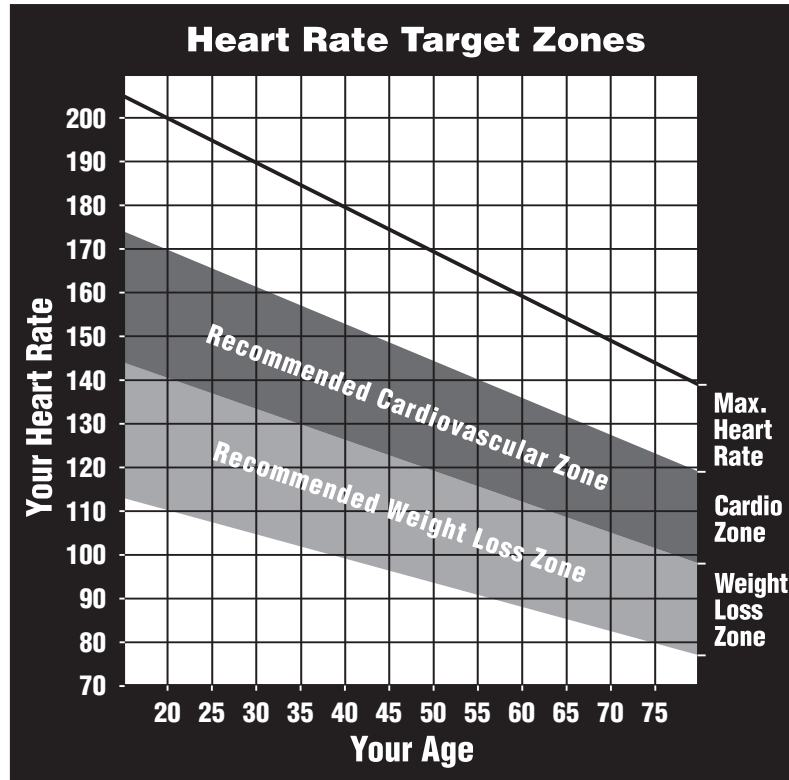

When the user maintains his or her heart rate between 70% and 85% of the maximum aerobic heart rate, the user is improving his or her overall cardiovascular/ cardiorespiratory fitness level. Maintaining the heart rate in either zone (weight loss or cardiovascular) for 30 minutes or more on a regular basis (minimum 3 times a week) provides the greatest benefits.

MANUAL MODE AND THE QUICKSTART KEY

Manual mode lets the user control the incline and running belt speed which affects the effort put into a workout. As with other programs, when a user completes the time limit set for the program, the automatic cool-down period begins.

A user can choose Manual mode in two different ways:

- pressing the QUICKSTART key at the Precor banner. QUICKSTART bypasses the remaining selections and starts the Manual program. Default values apply. Refer to pages 30 and 34.
- pressing ENTER at the Precor banner. This causes the C936i to display several Setup prompts. At the program prompt, a user selects the MANL program.

The Manual program profile appears as a flat line. Use the ▼▲ keys to adjust the incline or speed. (See pages 33 and 34 for more information on key function.) As the user proceeds with his or her workout, a blinking segment represents his or her position on the program.

CROSS COUNTRY PROGRAM

The Cross Country program has predetermined incline settings and a time limit of 30-minutes. A user can make changes to the running belt speed using the SPEED ▼▲ keys throughout the program. The preset incline can be overridden using the INCLINE ▲▼ keys, but the incline reverts to the original settings when you complete the program.

INTERVAL PROGRAM

The interval program on the C936i lets the user select the rest and work intervals according to his or her training regimen. Each rest interval is followed by one work interval. The user sets the incline and speed for first rest and work interval and the software repeats the intervals throughout the program. At any point during the workout, the user can change the settings of the current interval by simply pressing the ▼▲ keys. The software remembers the new settings and applies it to the appropriate rest or work interval from that point forward.

Important: *If a user entered his or her age during the Setup prompts and wears the chest strap or grasps both heart rate grips on the handrails, the user can adjust the rest or work intervals to keep his or her heart rate in its recommended zone. For the weight loss mode, try to maintain a heart rate at the lower end (55% of maximum heart rate) while in the “rest” intervals and keep it at 70% of maximum heart rate while in the “work” intervals. See Diagram 22 on page 42.*

To use the interval program, take the following steps:

1. Follow the instructions on page 37, *Quick Steps to Working Out*.
2. At the program prompt, use the ▼▲ key to select INTV.
3. Press ENTER to proceed to the next prompt. When a user finishes answering the Setup prompts, the Interval program begins.

To set the incline and speed levels for each interval, have the user take the following steps:

1. To program the rest interval, press the INCLINE ▼▲ keys and SPEED ▼▲ keys to change the corresponding levels. When the desired settings are displayed, simply continue working out—the user does not need to press ENTER.

The C936i returns to the “rest” settings at the beginning of each rest interval until the user readjusts it or end his or her workout.

2. The same procedure applies to specify the settings for the work interval.

The value that appears in the SEGMENT TIME field indicates the time remaining in the current interval. Each time the C936i changes intervals, it informs the user by displaying a message. When a user completes the time limit set for the program, the automatic cool-down period begins.

WEIGHT LOSS PROGRAM

The Precor Weight Loss program incorporates the latest findings on fat-burning and weight loss through exercise. It is based on research at the world-renowned Cooper Institute for Aerobics Research and it is designed to help the user burn the most fat during a 28-minute workout, while minimizing the risk of discomfort and injury. The Weight Loss program is similar to the Interval program. The C936i automatically adjusts the incline of the treadmill while in the rest or work intervals.

Note: For the C936i to detect a heart rate, the user must wear the chest strap. The chest strap is optional equipment that can be purchased from a dealer.

To use the Weight Loss program, follow the steps found in *Quick Steps to Working Out* on page 37. When the PROGRAM prompt appears, choose WTLS.

Important: During a workout, the user can change the incline, but doing so will cause the effectiveness of the Weight Loss program to vary.

Note: When the user completes the time limit set for the program, the automatic cool-down period begins.

RANDOM PROGRAM

The C936i Random program incline is predetermined, but the profile changes every time you access the program. A user can make changes to the running belt speed using the SPEED ▼▲ keys. The preset incline can be overridden using the INCLINE ▲▼ keys, but certain rules apply:

- ✓ a “0” percent incline exists for the first segment (column).
- ✓ the maximum range that the incline can be changed between columns is fixed at plus or minus 4 percent.

HEART RATE PROGRAM

Once the user sets a target heart rate and the running belt's speed, the C936i Heart Rate Program monitors the user's heart rate and automatically maintains it within a few beats per minute (bpm) of the selected target. Blinking lights on the SmartRate® bar graph appear to show the "zone" that the user is in.

Note: For the C936i to detect a heart rate, the user must wear the chest strap or hold onto both touch-sensitive grips on the handrails. The chest strap is optional equipment that can be purchased from your dealer.

To use the Heart Rate Program, have the user follow the steps found in *Quick Steps to Working Out* on page 37 and choose HRC at the PROGRAM prompt. For the Heart Rate Program to operate properly, a user's AGE **must** be entered during the Setup prompts. Once the user addresses the remaining Setup prompts, the following occurs:

- The software verifies that it detects a heart rate signal. You need to press the SPEED ▲ key to begin working out.

Note: If a user's heart rate cannot be detected (or transmitted through the chest strap or touch-sensitive grips), the letters "Hr" blink in the heart rate display. Once a heart rate is detected the number that corresponds to the user's heart rate appears.

- The treadmill provides a three-minute warm-up period before entering the Heart Rate Program. During this time, the user may make changes to the incline by using the INCLINE ▲▼ keys. He or she can press the SPEED ▼▲ keys to set the running belt's speed.

Note: If the user's heart rate moves into his or her heart rate zone during the three-minute warm-up period, the Heart Rate Program begins concurrently.

- After the warm-up period, the treadmill automatically adjusts the incline to keep the user's heart rate at the selected target. The SmartRate® display indicates which zone: cardiovascular or weight loss, that the user is in.

Note: A user can change the running belt's speed anytime during a workout, but doing so affects the treadmill's ability to maintain the target heart rate. It takes time for the treadmill to readjust the incline so that the user's heart rate remains on target.

CAUTION: A warning message appears if the user goes above his or her maximum recommended heart rate target zone. Heed the warning. Make sure that the user has permission from his or her personal physician before working out above the maximum recommended zone for his or her age and fitness level. See Diagram 22 on page 42 for the recommended target zones.

- When a user reaches the time limit, a cool-down period begins. The user can override the speed and incline by pressing the appropriate ▼ or ▲ keys.

Note: The speed remains constant, if the user was at or below 0.5 mph (1.0 kph).

Maintenance

The C936i is built to withstand the rigors of the health club environment. However, as club manager or owner, you are responsible for cleaning and maintaining the unit's integrity. If you fail to maintain the treadmill as described below, it could affect or void the Precor Limited Warranty.

DANGER — To reduce the risk of electrical shock, always unplug the unit from its power source before cleaning it or performing any maintenance tasks.

INSPECTION

Perform a daily inspection of the treadmill.

1. Look and listen for slipping belts, loose fasteners, unusual noises, worn or frayed power cords, and any other indications that the equipment may be in need of service. Obtain service should you notice any of the above.

Important: If you determine that the treadmill is in need of service, move it away from the main workout area and place an large "Out of Service" sign on it. While it is awaiting service, remove the power cord so no one can use the treadmill.

2. Check for worn, frayed, or missing safety lanyards. Replace missing or worn safety lanyards immediately. A safety lanyard with its security clip must be fastened to the treadmill's red STOP button. Do not allow users on a treadmill without it.

To order parts or to contact a Precor authorized service provider in your area, refer to *Obtaining Service* on page 7.

CLEANING THE EQUIPMENT

Most of the working mechanisms are protected inside the treadmill's hood and solid base. However, for efficient operation, the treadmill relies on low friction. To keep the friction low, the treadmill must be as clean as possible.

It is recommended that the running bed and belt be cleaned daily. Use a damp, soft cloth to clean the staging platform, running bed and between the belt and running bed surface as far as you can easily reach. This removes any dust or dirt which might affect the smooth operation of the unit.

CAUTION: Never pour water or spray liquids on the display console, handrails, or treadmill. Allow the treadmill to dry completely before using.

Periodically, clean the treadmill's frame, display console, handrails and running belt with a dampened (not dripping wet), *clean* cloth using a diluted solution of mild soap and water. To clean the grooves on the belt, use a soft nylon scrub brush. Vacuum the floor underneath the unit every week to prevent the accumulation of dust and dirt.

The Precor Heart Rate equipment requires little maintenance beyond keeping it dust free. Dampen a sponge or soft cloth in mild soap and water to wipe the chest strap. Dry the surface thoroughly with a clean towel.

ALIGNING THE RUNNING BELT

The correct alignment of the running belt is critical to the smooth operation of the treadmill. The belt is properly aligned at the factory. However, during shipping and handling or by use on an uneven surface, the belt may move off center and require a few simple adjustments.

Before aligning the running belt, check its operation by following the procedure in *Checking the Alignment of the Running Belt* on page 22. If you determine that the belt needs alignment, follow the instructions here.

CAUTION: Special care must be taken when aligning the running belt. Turn OFF the treadmill while adjusting or working near the rear roller. Remove any loose clothing and tie back your hair. Be very careful to keep your finger or any other object clear of the belt and rollers, especially in front of the roller and behind the deck. The treadmill will not stop immediately if an object becomes caught in the belt or rollers.

Realigning the belt takes a few simple adjustments. If you are unsure about this procedure, call Precor Customer Support (see *Obtaining Service* on page 7.)

Take the following steps to align the running belt on the treadmill. To ensure your safety, make all adjustments while the treadmill is OFF.

1. Make sure the treadmill is OFF and the running belt has completely stopped.
2. Locate the **left** belt adjustment bolt in the rear end cap of the treadmill. (To determine left and right, stand at the rear of the treadmill and face the display.) The direction you turn the bolt depends on how the belt is tracking. Make all belt adjustments on the **left rear corner bolt** using the hex key provided.
 - If the belt is off center to the LEFT, turn the adjusting bolt $\frac{1}{4}$ turn clockwise, which moves the running belt to the right.
 - If the belt tracks off center to the RIGHT, turn the bolt $\frac{1}{4}$ turn *counterclockwise*; this moves the belt to the left.

Important: Do not turn the adjusting bolt more than $\frac{1}{4}$ turn at a time. Overtightening the bolt can damage the treadmill.

3. Turn ON the treadmill, press QUICKSTART, and then increase the running belt speed to 3 mph (5 kph) by pressing SPEED ▲.

CAUTION: Stand to the side of the treadmill. The running belt begins moving automatically after you press QUICKSTART.

4. Observe the running belt for a couple of minutes. The belt should be centered on the running bed.

CAUTION: If you hear any chafing or the running belt appears to be getting damaged, stop the running belt immediately by pressing the red Stop key. Contact Precor Customer Support.

5. If the belt needs additional alignment, repeat steps 1 through 4 of this procedure until the belt is properly aligned.
6. Press the red STOP button. To return to the Precor banner, press RESET.

STORING THE CHEST STRAP

Store the chest strap transmitter in a place where dust and dirt cannot accumulate on it such as, a closet or drawer. Be sure to keep the chest strap protected from extremes in temperature. Do not store it in an area that may be exposed to temperatures below 32 degrees Fahrenheit.

SERVICING THE TREADMILL

Do not attempt to service the treadmill yourself except for the maintenance tasks described in this manual. The unit does not contain any user-serviceable parts that require lubrication. Refer to *Obtaining Service* on page 7.

LONG TERM STORAGE

When the treadmill is not in use for any length of time, turn it OFF. Ensure that the power cord is unplugged from the wall outlet and is positioned so that it will not become damaged or interfere with other equipment or people.

Thank You and Welcome to Precor



We are confident that you will be pleased with your purchase and that your new Precor equipment will help satisfy your customers' fitness needs, while helping you meet your business goals.

To allow us to serve you better, please take a few moments to complete and return your warranty registration.

YOU MAY ALSO REGISTER ONLINE AT
www.precor.com

If you have questions or need additional information, contact your local dealer or call Precor Customer Support at 800-786-8404.

Fold along dotted line and tape closed before mailing.

COMM.

PRECOR
USA
Precor Incorporated
20031 142nd Avenue NE
PO Box 7202
Woodinville, WA 98072-4002

PLACE
STAMP
HERE

TELL US ABOUT YOUR NEW PRECOR PRODUCTS

Date of Purchase:

Month	Day	Year

Purchased from (Dealer name):

--

Product Serial Number(s):

--

The serial number is located on the shipping box and on the product.

--

--

Add additional sheets of paper or register online at www.precor.com/warranty

Please indicate the type and number of products purchased:

- #: _____ Elliptical Fitness CrossTrainer (EFX®)
- #: _____ Treadmill #: _____ Stair Climber
- #: _____ Cycle #: _____ Strength Station
- #: _____ StretchTrainer™

TELL US ABOUT YOUR FACILITY

--

<input type="checkbox"/> Mr.	Name of Facility	
<input type="checkbox"/> Mrs.		
<input type="checkbox"/> Ms.	Contact Person — First Name	Last Name

Facility Address	Apt./Suite:
------------------	-------------

City	State	Zip Code
------	-------	----------

Area Code	Facility Telephone Number
-----------	---------------------------

--

Your Business Email Address

How many members do you have?

- Less than 100 100 - 500 500 - 1000 1000 - 2000 2001 +

What percentage of floor space do you allocate for cardio equipment?

- 0% to 20% 20% to 40% 40% to 60% 60% to 80% 80% to 100%

What type of equipment makes up your cardio offering (check all that apply)?

- Treadmills Ellipticals Cycles Stair Climbers Rowing Machines Other _____

What other brands of cardio equipment do you currently offer (check all that apply):

- Life Fitness True Cybex StarTrac Other _____

What other Precor equipment do you currently offer (check all that apply):

- EFX® Cycle StretchTrainer™
- Treadmill Stair Climber Strength Machine Other _____

TELL US ABOUT YOUR PURCHASE

Which best describes this purchase (check all that apply):

- First Precor product
- Replaces same type of product – different brand
- Replaces a Precor product of the same type
- Enhancement to equipment already owned

How did you FIRST become aware of this product (choose only one):

- Authorized Precor dealer Precor sales representative Trade show/conference
- Internet News report or product review Club/fitness magazine advertisement
- Trade/consumer magazine article Other _____

What factors MOST influenced your decision to purchase this product (choose up to three):

- Precor reputation Prior product experience Design/appearance Value for the price
- Special product features Warranty Service Rebate or sale price

Please detach and mail in the warranty registration within ten days of purchase.

Commercial Equipment Limited Warranty

PLEASE READ THESE WARRANTY TERMS AND CONDITIONS CAREFULLY BEFORE USING YOUR PRECOR INCORPORATED PRODUCT. BY USING THE EQUIPMENT, YOU ARE CONSENTING TO BE BOUND BY THE FOLLOWING WARRANTY TERMS AND CONDITIONS.

Limited Warranty.

Precor Incorporated warrants all new Precor products to be free from defects in materials and manufacture for the warranty periods set forth below. The warranty periods commence on the invoice date of the original purchase. This warranty applies only against defects discovered within the warranty period and extends only to the original purchaser of the product. Parts repaired or replaced under the terms of this warranty will be warranted for the remainder of the original warranty period only. To claim under this warranty, the buyer must notify Precor or your authorized Precor dealer within 30 days after the date of discovery of any nonconformity and make the affected product available for inspection by Precor or its service representative. Precor's obligations under this warranty are limited as set forth below.

Warranty Periods and Coverage.

Commercial Cardiovascular Products, also known as C-Series Products, (excluding StretchTrainer, Strength Products).

- Seven years frame, five years touch sensor display housing, two years parts, one year labor.
- For treadmills, five years motor fan, three years drive motor.
- For self-powered ellipticals and bikes, one year battery.
- For InSite, one year parts and labor.
- Labor coverage for options as defined below.

StretchTrainer

Five years frame, two years parts, 90 days upholstery, no labor.

Strength Products (S3.45 and S3.25 only)

Ten years frame; three years bearings, guide rods, cams, pulleys; one year belts, cables, hand grips, miscellaneous parts; 90 days upholstery; no labor.

Options / Accessories / Battery-powered or Self-Operated Devices

Many options or accessories have components that are connected internally or mounted inside the electronic console. The following guidelines determine the warranty for these components. If the internal components are installed by the factory or by an authorized dealer as part of the original sale and delivery, they have a warranty that is identical to the warranty of the equipment in which they are connected or mounted. If the internal components are not installed by the factory or by an authorized dealer as part of the original sale and delivery, they have a 90 days parts and labor limited warranty. All components that are not internally connected have a 90 days parts only limited warranty. Satisfactory proof of purchase is required in all cases.

Conditions and Restrictions.

This warranty is valid only in accordance with the conditions set forth below:

1. The warranty applies to the Precor product only while
 - a. it remains in the possession of the original purchaser and proof of purchase is demonstrated,
 - b. it has not been subjected to accident, misuse, abuse, improper service, or non-Precor modification.
 - c. claims are made within the warranty period.
2. Certain products are warranted for standard commercial use only (defined as use in non-fee paying clubs or facilities and less than 6 hours daily use. Unapproved use voids the warranty. Current standard commercial products include C936i, C932i, EFX524i, EFX534i).
3. This warranty does not cover damage or equipment failure caused by electrical wiring not in compliance with electrical codes or Precor owner's manual specifications, or failure to provide reasonable and necessary maintenance as outlined in the owner's manual.
4. Except in Canada, Precor does not pay labor outside the United States.
5. Warranties outside the United States and Canada may vary. Please contact your local Dealer for details.

This Limited Warranty shall not apply to:

1. Software (PROM) version upgrades.
2. Normal wear and tear, consumables and cosmetic items, including, but not limited to the following: grips, seats, and labels.
3. Repairs performed on Precor equipment missing a serial number or with a serial tag that has been altered or defaced.
4. Service calls to correct installation of the equipment or instruct owners on how to use the equipment.
5. Pickup and delivery involved with repairs.
6. Any labor costs incurred beyond the applicable labor warranty period.

Complete this portion and keep for your records.

Purchased From: _____ Example: Dealer or store name.
Phone Number: _____ Example: Dealer or store telephone number.
Product/model: _____ Example: EFX534i or C966i
Serial number: _____

The serial number is found on the shipping container.

Disclaimer and Release.

The warranties provided herein are the exclusive warranties given by Precor and supersede any prior, contrary or additional representations, whether oral or written. ANY IMPLIED WARRANTIES, INCLUDING THE WARRANTY OF MERCHANTABILITY OR FITNESS FOR A PARTICULAR PURPOSE THAT APPLY TO ANY PARTS DESCRIBED ABOVE ARE LIMITED IN DURATION TO THE PERIODS OF EXPRESS WARRANTIES GIVEN ABOVE FOR THOSE SAME PARTS. PRECOR HEREBY DISCLAIMS AND EXCLUDES THOSE WARRANTIES THEREAFTER. Some States do not allow limitations on how long an implied warranty lasts, so the above limitation may not apply to you. PRECOR ALSO HEREBY DISCLAIMS AND EXCLUDES ALL OTHER OBLIGATIONS OR LIABILITIES, EXPRESS OR IMPLIED, ARISING BY LAW OR OTHERWISE, WITH RESPECT TO ANY NONCONFORMANCE OR DEFECT IN ANY PRODUCT, INCLUDING BUT NOT LIMITED TO: (A) ANY OBLIGATION, LIABILITY, RIGHT, CLAIM OR REMEDY IN TORT, WHETHER OR NOT ARISING FROM THE NEGLIGENCE OF PRECOR OR ITS SUPPLIERS (WHETHER ACTIVE, PASSIVE OR IMPUTED); AND (B) ANY OBLIGATION, LIABILITY, RIGHT, CLAIM OR REMEDY FOR LOSS OF OR DAMAGE TO ANY EQUIPMENT. This disclaimer and release shall apply even if the express warranty set forth above fails of its essential purpose.

Exclusive Remedies.

For any product described above that fails to conform to its warranty, Precor will provide, at their option, one of the following: (1) repair; (2) replacement; or (3) refund of the purchase price. Precor Limited Warranty service may be obtained by contacting the authorized dealer from whom you purchased the item. Precor compensates Servicercers for warranty trips within their normal service area to repair commercial equipment at the customer's location. You may be charged a trip charge outside the service area. THESE SHALL BE THE SOLE AND EXCLUSIVE REMEDIES OF THE BUYER FOR ANY BREACH OF WARRANTY.

EXCLUSION OF CONSEQUENTIAL AND INCIDENTAL DAMAGES.

PRECOR AND/OR ITS SUPPLIERS SHALL HAVE NO OBLIGATION OR LIABILITY, WHETHER ARISING IN CONTRACT (INCLUDING WARRANTY), TORT (INCLUDING ACTIVE, PASSIVE, OR IMPUTED NEGLIGENCE AND STRICT LIABILITY), OR OTHERWISE, FOR DAMAGE TO THE EQUIPMENT, PROPERTY DAMAGE, LOSS OF USE, REVENUE OR PROFIT, COST OF CAPITAL, COST OF SUBSTITUTE EQUIPMENT, ADDITIONAL COSTS INCURRED BY BUYER (BY WAY OF CORRECTION OR OTHERWISE) OR ANY OTHER INCIDENTAL, SPECIAL, INDIRECT, OR CONSEQUENTIAL DAMAGES, WHETHER RESULTING FROM NONDELIVERY OR FROM THE USE, MISUSE OR INABILITY TO USE THE PRODUCT. This exclusion applies even if the above warranty fails of its essential purposes and regardless of whether such damages are sought for breach of warranty, breach of contract, negligence, or strict liability in tort or under any other legal theory. Some states do not allow the exclusion or limitation of incidental or consequential damages, so the above limitation may not apply to you.

This warranty gives you specific legal rights, and you may also have other rights, which vary from state to state.

C936i Standard Commercial Treadmill featuring Heart Rate and SmartRate® Systems

Product Specifications:

Length: 79 inches (201 cm)
Width: 34 inches (85 cm)
Height: 55 inches (140 cm)
Weight: 280 lbs (127 kg)
Shipping weight: 345 lbs (156 kg)
Running surface: 57 inches x 20 inches
(145 cm x 51 cm)
Motor: 3.0 hp continuous duty
Power: 120/240 VAC (50/60Hz)
Speed: 0.5 to 11 mph (1 to 18 kph)
Incline: 0.5% to 15% grade
Frame: Powder-coated steel

Regulatory Approval: FCC, ETL, CE

Electronic Specifications

C936i Programs: 6

Cross Country
Heart Rate*
Interval
Manual
Random
Weight Loss

C936i Display Readouts:

Calories
Calories Per Minute
Distance
Heart Rate*
Incline
Mets
Program Profile
Speed
SmartRate® *
Time

* Requires that the user wear a chest strap, or place both hands on the touch-sensitive handrail grips.

C936i Features:

CSAFE
Heart Rate Telemetry
QuickStart™
Reversible Deck
SmartRate®
Touch-Sensitive Display

PRECOR USA

Precor Incorporated
20031 142nd Avenue NE
P.O. Box 7202
Woodinville, WA USA 98072-4002

Precor, CrossRamp, EFX, M, Move Beyond and SmartRate are registered trademarks of Precor Incorporated.
QuickStart is a trademark of Precor Incorporated.
Copyright 2004 Precor Incorporated.
Specifications subject to change without notice.
www.precor.com

C936i Lit Kit# 44132-111
OM# 44159-111
Online OM# 44159-411
Registration Card# 45622-101
Warranty# 36286-111
18 February 2005

NOTICE:

Precor is widely recognized for its innovative, award winning designs of exercise equipment. Precor aggressively seeks U.S. and foreign patents for both the mechanical construction and the visual aspects of its product design. Any party contemplating the use of Precor's product designs is hereby forewarned that Precor considers the unauthorized appropriation of its proprietary rights to be a very serious matter. Precor will vigorously pursue all unauthorized appropriation of its proprietary rights.