

# ZANUSSI

## REFRIGERATOR

---

### ZTR 57 R

INSTRUCTION BOOKLET

# CONTENTS

## Instructions for the User

|   |           |
|---|-----------|
| <b>Important Safety Instructions</b>            | <b>3</b>  |
| <b>Description of the Appliance</b>             | <b>4</b>  |
| <b>Operation</b>                                | <b>4</b>  |
| Before use                                      | 4         |
| Setting the temperature                         | 4         |
| Fresh food refrigeration                        | 5         |
| The door shelves                                | 5         |
| Normal Operating Sounds                         | 5         |
| Use and features of the «CRISP'N' FRESH» filter | 6         |
| <b>Health and Safety Guidelines</b>             | <b>6</b>  |
| <b>Defrosting</b>                               | <b>7</b>  |
| <b>Maintenance and Cleaning</b>                 | <b>7</b>  |
| Internal cleaning                               | 7         |
| External cleaning                               | 7         |
| Changing the light bulb                         | 8         |
| When the appliance is not in use                | 8         |
| <b>Something Not Working?</b>                   | <b>8</b>  |
| <b>Service and Spare Parts</b>                  | <b>9</b>  |
| <b>Customer Care Department</b>                 | <b>9</b>  |
| <b>Zanussi Service Force</b>                    | <b>10</b> |
| <b>Guarantee Conditions</b>                     | <b>12</b> |

## Instructions for the Installer

|                                 |           |
|---------------------------------|-----------|
| <b>Technical Specifications</b> | <b>13</b> |
| <b>Installation</b>             | <b>13</b> |
| Positioning                     | 13        |
| Door reversal                   | 14        |
| <b>Electrical Connection</b>    | <b>15</b> |



# IMPORTANT SAFETY INSTRUCTIONS

These warnings are provided in the interests of your safety. Ensure that you understand them all before installing or using this appliance. Your safety is of paramount importance. If you are unsure about any of the meanings of these warnings contact the Customer Care Department.

## Prior to Installation

- Check the appliance for transport damage. Under no circumstance should a damaged appliance be installed. In the event of damage please contact your retailer.

## Installation

- This appliance is heavy. Care should be taken when moving it.
- It is dangerous to alter the specifications or attempt to modify this product in any way.
- Ensure that the appliance does not stand on the electrical supply cable.  
**Important:** if the supply cable is damaged, it must be replaced by authorized service or qualified personnel using a special cable of the same type.
- Any electrical work required to install this appliance should be carried out by a qualified electrician or competent person.
- Parts which heat up should not be exposed. Whenever possible, the back of the appliance should be close to a wall, but leaving the required distance for ventilation, as stated in the installation instructions.
- The appliance should be left for 2 hours after installation before it is turned on, in order to allow the refrigerant to settle.

## Refrigerant

- The refrigerant isobutane (R600a) is contained within the refrigerant circuit of the appliance, a natural gas with a high level of environmental compatibility, which is nevertheless flammable.
- During transportation and installation of the appliance, be certain that none of the components of the refrigerant circuit become damaged.
- If the refrigerant circuit should become damaged:
  - avoid open flames and sources of ignition.
  - thoroughly ventilate the room in which the appliance is situated.

## Child Safety

- Do not allow children to tamper with the controls or play with the product.
- There is a risk of suffocation! Keep packaging material away from children!

## General Safety

- **This appliance contains hydrocarbons in its cooling unit; maintenance and recharging must therefore only be carried out by authorised technicians.**
- **Take utmost care when handling your appliance so as not to cause any damages to the cooling unit with consequent possible fluid leakages.**
- **The appliance must not be located close to radiators or boilers.**
- **Avoid prolonged exposure of the appliance to direct sunlight.**
- **Do not use other electrical appliances (such as ice cream makers) inside of refrigerating appliances.**

## During Use

- This appliance is designed for domestic use only, specifically for the storage of edible foodstuffs. It is not intended for commercial or industrial use.
- Containers with flammable gases or liquids can leak at low temperatures. Do not store any containers with flammable materials, such as spray cans, fire extinguisher refill cartridges etc. in the refrigerator.

## Maintenance and Cleaning

- Before cleaning, always switch off the appliance and disconnect from the electrical supply.
- When unplugging always pull the plug from the mains socket, do not pull on the cable.

## Servicing

- This product should be serviced by an authorised engineer and only genuine spare parts should be used.
- Under no circumstances should you attempt to repair the appliance yourself. Repairs carried out by inexperienced persons may cause injury or serious malfunctioning. Contact your local Service Force Centre.

## At the end of the Appliance Life

- When disposing of your appliance use an authorised disposal site.
- Remove the plug and ensure that any locks or catches are removed, to prevent young children being trapped inside.

# **i** DESCRIPTION OF THE APPLIANCE

- ① Dairy compartment
- ② Can storage shelf with egg tray
- ③ Bottle storage shelf
- ④ Salad bins
- ⑤ Glass shelf (for storing fresh meat) with Crisp'n' Fresh filter
- ⑥ Storage shelves (one with flap)
- ⑦ Thermostat control

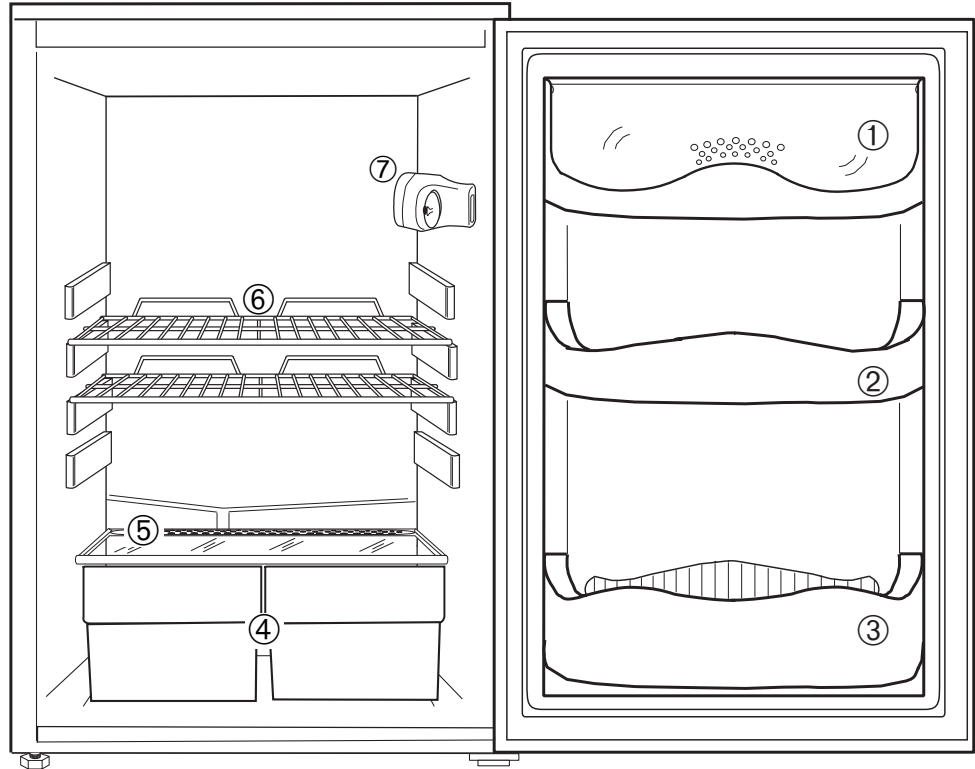

# **i** OPERATION

## Before use

Remove all securing tapes. Wash inside the appliance with lukewarm water and bicarbonate of soda (5 ml to 0.5 litre of water). Do not use soap or detergent as the smell may linger. Dry thoroughly.

## Setting the temperature

The temperature inside the refrigerator is regulated by a thermostat with 6 temperature positions and one «OFF» (O) position.

Position 1 = minimum coldness

Position 6 = maximum coldness

Turn the thermostat dial to the required position.

An intermediate position is usually the most suitable, although the temperature will be affected by:

- Room temperature
- How often the door is opened
- How much food is stored
- Position of the appliance

In determining the correct temperature control setting all these factors have to be considered and some experimentation may be necessary.

When altering the temperature setting, allow 24 hours for the temperature to stabilise before making further changes.



### Important

**During prolonged periods of abnormally hot weather, if the thermostat is set on too high a number, the cooling system may operate continuously and the fridge cooling plate may not defrost. Turning the knob to a lower number will cause the automatic defrosting to resume.**

## Fresh food refrigeration

To obtain the best performance, do not store warm food or evaporating liquids in the refrigerator; do cover or wrap the food, particularly if it has a strong flavour. Do not cover the shelves with any protective material, such as paper, cardboard or plastic, which may obstruct the air circulation through them.

To help you use your refrigerator correctly, here are some more useful hints:

**Raw meat** (beef, pork, lamb & chicken or poultry): wrap in polythene bags and place on top of the salad drawers.

**Meat can only be stored safely in this way for one or two days at the most.**

**Fruit & vegetables:** these should be thoroughly cleaned and placed in the bottom salad drawers.

**Butter & cheese:** these should be placed in special airtight containers or wrapped in aluminium foil or polythene bags to exclude as much air as possible.

**Milk bottles:** these should have a cap and should be stored in the bottle rack on the door.

The walls of the refrigerator are equipped with runners so that shelves can be positioned as desired.

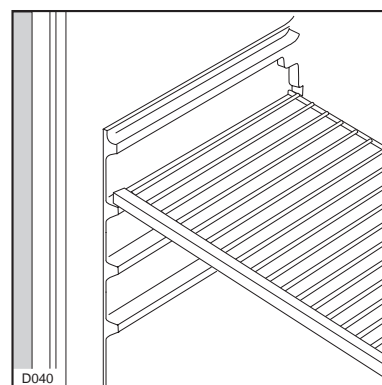

## The door shelves

To permit storage of food packages of various sizes, the central door shelf can be adjusted in height.

To do this proceed as in the figure.

The top shelf can be removed for easier cleaning.

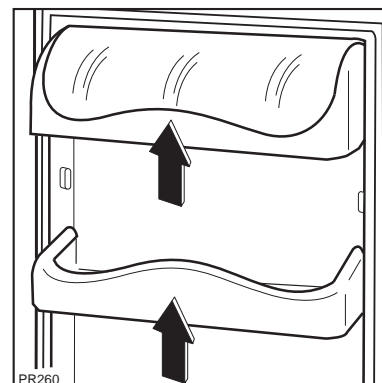

## Normal Operating Sounds

You may hear faint gurgling or bubbling sounds when the refrigerant is pumped through the coils or tubing at the rear, to the cooling plate.

When the compressor is on, the refrigerant is being pumped round, and you will hear a whirring sound or pulsating noise from the compressor.

A thermostat controls the compressor, and you will hear a faint 'click' when the thermostat cuts in and out.

## Use and features of the «CRISP'N' FRESH» filter

"Crisp'N' Fresh" is the glass shelf on top of the salad crispers which is fitted with special removable green filters.

These filters allow cool air from the fridge to circulate through the drawers but help prevent moisture loss. By retaining moisture in foods such as fresh fruit, vegetables and salad they are kept fresher for longer.

### Cleaning the filter

The filter is held by two small support frames which press into position and are therefore easily removed for cleaning.

To do this, turn the glass shelf upside down and release the frames as shown in the figure. The filters and the glass cover can be washed gently in warm soapy water, they should not be put in the dishwasher.

Replacement filters can be purchased as a spare part from your local Service Force Centre.

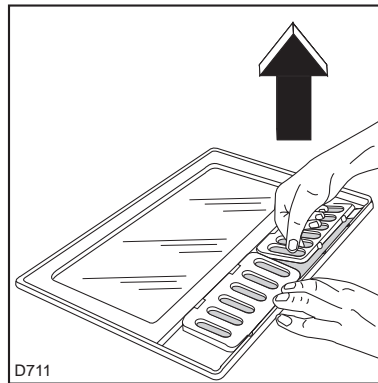
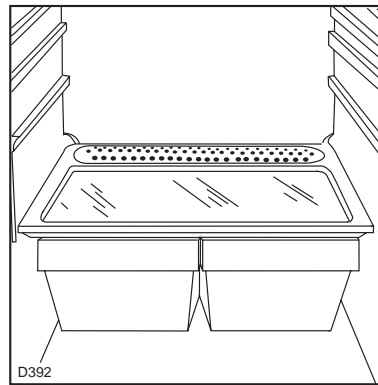

## **i** HEALTH AND SAFETY GUIDELINES

**Because of consumer demand, preservatives have been removed from many pre-prepared foods. This together with the changes in shopping habits to a once-a-week shop, mean that safe handling and storage of food is even more important than ever.**

**The following tips should help you to ensure that the food in your home is in as perfect condition as possible.**

- Keep the time between buying chilled food and placing it in your fridge as short as possible. Tests showed that the temperature of 1 litre of orange juice rose to 22°C in an hour between the supermarket and home. It then took 11 hours to get down to 7°C in the refrigerator.
- Keep the refrigerator door closed as much as possible.
- Do not push food together too much, try to allow air to circulate around each item.
- Cool cooked food as quickly as possible but do NOT place in the refrigerator until cool. (Leave food in a cool place in order that it can then be placed in the refrigerator as soon as possible).
- Do NOT mix raw and cooked meat, they must be in separate containers. Take care not to let the meat juices drip onto other food. If the meat does drip, remove everything and clean thoroughly.
- Do not store food uncovered.
- Remove suspect food from your refrigerator and clean the interior (see "Maintenance and Cleaning").
- Never allow spillages to dry and harden.
- Store eggs in the egg rack provided in the refrigerator door. Discard any broken or chipped eggs.
- Regularly check the refrigerator door seal to ensure that it is clean and free from debris.
- Always wash your hands with soapy water and dry them with a clean towel before handling food.
- Keep work surfaces clean and avoid cross contamination by not using the same work surface or knife, without washing them thoroughly in between.

# DEFROSTING

The refrigerator automatically defrosts every time the compressor stops. The water is discharged, via the pipe, into a tray located at the back of the appliance above the compressor, where it evaporates.



## Important

To avoid defrost water overflowing into the fridge, periodically clean the water discharge hole in the centre of the V shaped drip collector at the back of the refrigerator compartment behind the salad bins. Use the special cleaner provided which you will find already inserted into the discharge hole.

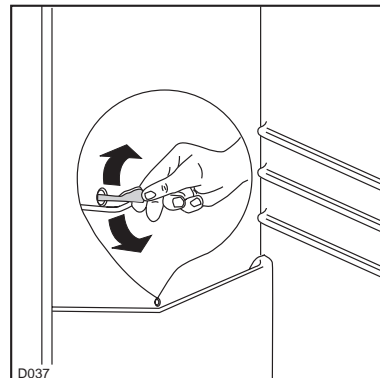

# MAINTENANCE AND CLEANING

Before any maintenance or cleaning work is carried out, DISCONNECT the appliance from the ELECTRICITY supply.



## Warning

This appliance contains hydrocarbons in its cooling unit maintenance and recharging must therefore only be carried out by authorised technicians.

## Internal cleaning

Clean the inside and accessories with warm water and bicarbonate of soda (5ml to 0.5 litre of water). Rinse and dry thoroughly.

**NEVER USE DETERGENTS, ABRASIVE POWDERS, HIGHLY PERFUMED CLEANING PRODUCTS OR WAX POLISHES, TO CLEAN THE INTERIOR AS THESE WILL DAMAGE THE SURFACE AND LEAVE A STRONG SMELL.**

Clean the drain hole of the water trough at regular intervals and make sure that the drain hole is never obstructed, so that the defrost water may flow freely.

## External cleaning

Wash the outer cabinet with warm soapy water. Do NOT use abrasive products.

Once or twice a year dust the condenser (black grill) and the compressor at the back of the appliance, with a brush or vacuum cleaner, see the figure.

You MUST ensure that the appliance is switched OFF. An accumulation of dust will affect the performance of the appliance and cause excessive electricity consumption.

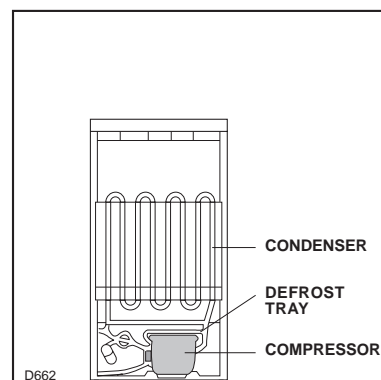

## Changing the light bulb

Should the interior light fail to work, first switch off the appliance and disconnect from the electricity supply, then replace the bulb as follows:

1. Unscrew the light cover and then pull it outward by pressing as shown in the figure.
2. Unscrew the bulb and replace it with a new 15 watt bulb (available from your nearest Zanussi Service Centre).
3. Replace the light cover by sliding it into its original position and replacing the screw.

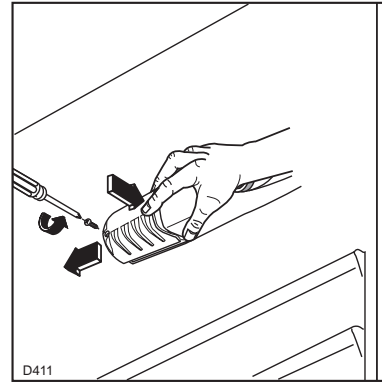

## When the appliance is not in use

When the appliance is not in use for long periods, disconnect from the electricity supply, empty all foods and clean the appliance, leaving the door ajar to prevent unpleasant smells.

# SOMETHING NOT WORKING?

**Before** contacting your local Service Force Centre check the following points.

**IMPORTANT:** If you call out an engineer to a fault listed below, or to repair a fault caused by incorrect use or installation, a charge will be made even if the appliance is under guarantee.

| Symptom  | Solution  |
|--|---|
| <b>No power to appliance</b>                     | <ul style="list-style-type: none"> <li>- Check there is power at the socket.</li> <li>- Check there is not a power cut by checking the household lights.</li> <li>- Check the fuse has not blown.</li> </ul>  |
| <b>The light does not come on</b>                | <ul style="list-style-type: none"> <li>- Ensure that the bulb is correctly fitted.</li> <li>- Replace the bulb if it has blown.</li> <li>- Check the door light switch is not jammed.</li> </ul>  |
| <b>The temperature in the fridge is too high</b> | <ul style="list-style-type: none"> <li>- Check the ambient temperature is within the appliances operating limits of 10°C to 32°C. Relocate the appliance if necessary.</li> <li>- Check the thermostat control knob is turned to the correct setting relative to ambient conditions.</li> </ul>   |
| <b>The compressor runs continuously</b>          | <ul style="list-style-type: none"> <li>- Adjust the thermostat control knob to give correct temperature control. See page 5.</li> <li>- Check that the door is closed.</li> <li>- Large quantities of food have recently been placed in the cabinet and/or door is frequently opened.</li> <li>- Check that air ventilation is not obstructed.</li> </ul> |
| <b>Excessive frost and ice has built up</b>      | <ul style="list-style-type: none"> <li>- Ensure the door is not left open.</li> <li>- Check that nothing is preventing the door from closing.</li> <li>- Is the door gasket intact and clean.</li> </ul>  |
| <b>Noise</b>                                     | <ul style="list-style-type: none"> <li>- Refer to normal operating sounds.</li> </ul>   |
| <b>Water under the salad bin</b>                 | <ul style="list-style-type: none"> <li>- Check the drain hole is not blocked (see "Maintenance and Cleaning").</li> </ul>   |

If after the above checks, there is still a fault, call your local Service Force Centre. In-guarantee customers should ensure that the above checks have been made as the engineer will make a charge if the fault is not a mechanical or electrical breakdown. Please note that proof of purchase is required for any in-guarantee service calls.



# SERVICE AND SPARE PARTS



In the event of your appliance requiring service, or if you wish to purchase spare parts, please contact your local Zanussi Service Force Centre by telephoning:-

**08705 929929**

Your telephone call will be automatically routed to the Service Force Centre covering your post code area. The addresses are listed on the following pages.

Before calling out an engineer, please ensure you have read the details under the heading 'Something Not Working'.

When you contact the Service Centre you will need to give the following details.

1. Your name, address and post code
2. Your telephone number
3. Clear and concise details of the fault
4. The model serial no. of the appliance (found on the rating plate)
5. The purchase date

## CUSTOMER CARE DEPARTMENT

For general enquiries concerning your Zanussi appliance or for further information on Zanussi products, you are invited to contact our Customer Care Department by letter or telephone or visit our website at [www.zanussi.co.uk](http://www.zanussi.co.uk)

Customer Care Department  
Zanussi  
55-77 High Street  
Slough  
Berkshire  
SL1 1DZ

Tel: 08705 727727 (\*)

(\*) calls to this number may be recorded for training purposes.



# Zanussi Service Force



To contact your local Zanussi Service Force Centre telephone **08705 929 929**

|   |  |                                    |   |                                 |   |
|---|--|------------------------------------|---|---------------------------------|---|
| <b>CHANNEL ISLANDS</b>                  |  | <b>ORKNEY</b><br>(M65)             | Corsie Domestics<br>7 King Street<br>Kirkwall<br>Orkney KW15                        | <b>NORTH EAST</b>               |   |
| <b>GUERNSEY</b>                         | Guernsey Electricity<br>PO Box 4<br>Vale, Guernsey<br>Channel Islands                                    | <b>PERTH</b>                       | Hydro Electrical<br>Inveralmond House<br>Ruthvenfield Road<br>Perth PH1 3AQ         | <b>GATESHEAD</b><br>(M39)       | Unit 356a<br>Dukesway Court<br>Dukesway<br>Team Valley<br>Gateshead NE11 0BH                |
| <b>JERSEY</b>                           | Jersey Electricity Company<br>PO Box 45<br>Queens Road<br>St Helier<br>Jersey<br>Channel Islands JE4 8NY | <b>PERTH</b><br><br>(OWN SALES)    | Graham Begg<br>Unit 4<br>Airport Ind Estate<br>Wick KW1 4QS                         | <b>GRIMSBY</b><br>(M42)         | 15 Hainton Avenue<br>Grimsby<br>South Humberside<br>DN32 9AS                                |
| <b>SCOTLAND</b>                         |  | <b>SHETLAND</b><br><br>(OWN SALES) | Tait Electronic Systems Ltd<br>Holmsgarth Road<br>Lerwick<br>Shetland ZE1 0PW       | <b>HULL</b><br>(M41)            | Unit 1<br>Boulevard Industrial Estate<br>Hull<br>HU3 4AY                                    |
| <b>ABERDEEN</b><br>(M05)                | 54 Claremont Street<br>Aberdeen AB10 6RA   | <b>SHETLAND</b><br><br>(OWN SALES) | Bolts Shetland Ltd.<br>26 North Road<br>Lerwick<br>Shetland ZE1 0PE                 | <b>LEEDS</b><br>(M37)           | 64-66 Cross Gates Road<br>Leeds<br>LS15 7NN   |
| <b>AUCHTERMUCHY</b><br>(M03)            | 33a Burnside<br>Auchtermuchy<br>Fife KY14 7AJ  | <b>WHALSAY</b><br><br>(OWN SALES)  | Leask Electrical<br>Harisdale<br>Symbister, Whalsay<br>Shetland ZE2 9AA             | <b>NEWTON AYCLIFFE</b><br>(M45) | Unit 16<br>Gurney Way<br>Aycliffe Industrial Estate<br>Newton Aycliffe<br>DL5 6UJ           |
| <b>BLANTYRE</b><br>(M07)                | Unit 5<br>Block 2<br>Auchenraith Ind. Estate<br>Rosendale Way<br>Blantyre G72 0NJ                        | <b>NORTHERN IRELAND</b>            |   | <b>SHEFFIELD</b><br>(M38)       | Pennine House<br>Roman Ridge Ind.<br>Roman Ridge Road<br>Sheffield S9 1GB                   |
| <b>DUMFRIES</b><br>(M01)                | 93 Irish Street<br>Dumfries<br>Scotland DG1 2 PQ   | <b>BELFAST</b><br>(M27)            | Owenmore House<br>Kilwee Business Park<br>Upper Dunmury Lane<br>Belfast<br>BT17 0HD | <b>NORTH WEST</b>               |   |
| <b>DUNOON</b><br>(M67)                  | Brair Hill<br>7 Hill Street<br>Dunoon<br>Argyll PA23 7AL   | <b>WALES</b>                       |   | <b>BIRKENHEAD</b><br>(M11)      | 1 Kelvin Park<br>Dock Road<br>Birkenhead<br>L41 1LT   |
| <b>GLASGOW</b><br>(M04)                 | 20 Cunningham Road<br>Clyde Estate<br>Rutherglen<br>Glasgow G73 1PP                                      | <b>CARDIFF</b><br>(M28)            | Guardian Industrial Estate<br>Clydesmuir Road<br>Tremorfa<br>Cardiff<br>CF2 2QS     | <b>CARLISLE</b><br>(M10)        | Unit 7<br>James Street Workshops<br>James Street<br>Carlisle<br>Cumbria CA2 5AH             |
| <b>INVERNESS</b><br>(M06)               | Unit 3B<br>Smithton Ind. Estate<br>Smithton<br>Inverness IV1 AJ  | <b>CLYWD</b><br>(M14)              | Unit 6-7 Coed – Parc<br>Abergele Road<br>Rhuddlan<br>Clwyd<br>Wales<br>LL18 5UG     | <b>ISLE OF MAN</b><br>(M64)     | South Quay Ind. Estate<br>Douglas<br>Isle of Man<br>IM1 5AT                                 |
| <b>ISLE OF ARRAN</b><br><br>(OWN SALES) | Arran Domestics<br>Unit 4 The Douglas Centre<br>Brodict<br>Isle of Arran KA27 8AJ                        | <b>DYFED</b><br>(M77)              | Maes Y Coed<br>High Mead<br>Llanybydder<br>Carmarthenshire<br>SA40 9UL              | <b>LIVERPOOL</b><br>(M15)       | Unit 1<br>Honeys Green Precinct<br>Honeys Green Lane<br>Liverpool<br>L12 9JH                |
| <b>ISLE OF BARRA</b><br><br>(OWN SALES) | J Zerfah<br>244 Bruernish<br>Isle of Barra<br>Western Islands HS9 5QY                                    | <b>HAVERFORDWEST</b><br>(M75)      | Cromlech Lodge<br>Ambleston<br>Haverfordwest<br>Pembrokeshire<br>SA62 5DS           | <b>MANCHESTER</b><br>(M09)      | Unit B<br>Central Industrial Estate<br>St Marks Street<br>Bolton<br>BL3 6NR                 |
| <b>ISLES OF BUTE</b>                    | Walker Engineering<br>Glenmhor<br>Upper Serpentine Road<br>Rothesay<br>Isle of Bute PA20 9EH             | <b>OSWESTRY</b><br>(M17)           | Plas Ffynnon<br>Warehouse<br>Middleton Road<br>Oswestry<br>SY11 2PP                 | <b>PRESTON</b><br>(M13)         | Unit 250<br>Dawson Place<br>Walton Summit<br>Bamber Bridge<br>Preston<br>Lancashire PR5 8AL |
| <b>ISLE OF LEWIS</b>                    | ND Macleod<br>16 James Street<br>Stornoway<br>Isle of Lewis PA87 2QW                                     |                                    |   | <b>STOCKPORT</b><br>(M16)       | Unit 20 Haigh Park<br>Haigh Avenue<br>Stockport<br>SK4 1QR                                  |
| <b>KELSO</b><br>(M08)                   | 2-8 Wood Market<br>Kelso<br>Borders TD5 7AX  |                                    |   |                                 |   |



# Zanussi Service Force



To contact your local Zanussi Service Force Centre telephone **08705 929 929**

|                            |  |                                 |  |                      |  |
|----------------------------|--|---------------------------------|--|----------------------|--|
| <b>MIDLANDS</b>            |  | <b>LONDON &amp; EAST ANGLIA</b> |  | SUNBURY (M63)        | Unit 1a<br>The Summit<br>Hanworth Road<br>Hanworth Ind. Estate<br>Sunbury on Thames<br>TW16 5D |
| BIRMINGHAM (M18)           | 66 Birch Road East<br>Wyrley Road Ind. Estate<br>Witton<br>Birmingham<br>B6 6DB              | BECKENHAM (M79)                 | 11a Gardener Ind. Estate<br>Kent House Lane<br>Beckenham<br>Kent BR3 1QZ     | <b>SOUTH EAST</b>    |  |
| BOURNE (M44)               | Manning Road Ind. Estate<br>Pinfold Road<br>Bourne<br>PE10 9HT                               | CHELMSFORD (M47)                | Hanbury Road<br>Widford Ind. Estate<br>Chelmsford<br>Essex<br>CM12 3AE       | ASHFORD (M58)        | Unit 2<br>Bridge Road Business Est.<br>Bridge Road<br>Ashford<br>Kent TN2 1BB                  |
| BRIDGNORTH (M72)           | 68 St. Mary's Street<br>Bridgnorth<br>Shropshire<br>WV16 4DR                                 | COLINDALE (M53)                 | Unit 14<br>Capitol Park<br>Capitol Way<br>Colindale<br>London NW9 0EQ        | FLEET (M59)          | Unit 1<br>Redsfield Ind. Estate<br>Church Crookham<br>Fleet<br>Hampshire GU13 0RD              |
| GLOUCESTER (M23)           | 101 Rycroft Street<br>Gloucester<br>GL1 4NB  | ELTHAM (M78)                    | 194 Court Road<br>Mottingham<br>Eltham<br>London SE9 4EW                     | HAYWARDS HEATH (M55) | 21-25 Bridge Road<br>Haywards Heath<br>Sussex RH16 1UA   |
| HEREFORD (M31)             | Unit 3<br>Bank Buildings<br>Cattle market<br>Hereford<br>HE4 9HX                             | ENFIELD (M49)                   | 284 Alma Road<br>Enfield<br>London EN3 7BB                                   | <b>SOUTH WEST</b>    |  |
| HIGHAM FERRERS (M51)       | 30 High Street<br>Higham Ferrers<br>Northants<br>NN10 8BB                                    | GRAVESEND (M57)                 | Unit B4<br>Imperial Business Estate<br>Gravesend<br>Kent<br>DA11 0DL         | BARNSTAPLE (M30)     | Main Road<br>Fremington<br>Barnstaple<br>North Devon EX31 2NT                                  |
| ILKESTON (M43)             | Unit 2<br>Furnace Road<br>Ilkeston DE7 5EP   | HARPENDEN (M46)                 | Unit 4<br>Riverside Estate<br>Coldharbour Lane<br>Harpenden<br>AL5 4UN       | BOURNEMOUTH (M26)    | 63-65 Curzon Road<br>Bournemouth<br>Dorset<br>BH1 4PW  |
| LEICESTER (M22)            | Unit 7<br>Oaks Ind. Estate<br>Coventry Road<br>Narborough<br>Leicestershire<br>LE0 5GF       | LETCHWORTH (M50)                | 16-17 Woodside Ind. Estate<br>Works Road<br>Letchworth<br>Herts<br>SG6 1LA   | BRIDGEWATER (M35)    | 6 Hamp Ind. Estate<br>Bridgewater<br>Somerset TA6 3NT  |
| LINCOLN (M40)              | Unit 8<br>Stonefield Park<br>Clifton Street<br>Lincoln<br>LN5 8AA                            | LONDON (M76)                    | 2/4 Royal Lane<br>Yiewsley<br>West Drayton<br>Middlesex<br>UB7 8DL           | BRISTOL (M25)        | 11 Eldon Way<br>Eldonwall Trading<br>Bristol<br>Avon BS4 3QQ                                   |
| NEWCASTLE UNDER LYME (M12) | 18-21 Croft Road<br>Brampton Ind. Estate<br>Newcastle under Lyme<br>Staffordshire<br>ST5 0TW | MAIDENHEAD (M60)                | Reform Road<br>Maidenhead<br>Berkshire<br>SL6 8BY                            | EMSWORTH (M33)       | 266 Main Road<br>Southbourne<br>Emsworth<br>PO10 8JL   |
| REDDITCH (M20)             | 13 Thornhill Road<br>North Moons Moat<br>Redditch<br>Worcestershire<br>B98 9ND               | MOLESEY (M61)                   | 10 Island Farm Avenue<br>West Molesey<br>Surrey<br>KT8 2UZ                   | ISLE OF WIGHT (M34)  | Unit 8<br>Enterprise Court<br>Ryde Business Park<br>Ryde<br>Isle of Wight PO33 1DB             |
| TAMWORTH (M19)             | Unit 3<br>Sterling Park<br>Claymore<br>Tamworth<br>B77 5DO                                   | NEWBURY (M24)                   | 9 Pipers Court<br>Berkshire Drive<br>Thatcham<br>Berkshire<br>RG19 4ER       | NEWTON ABBOT (M29)   | Unit 2<br>Zealley Ind. Estate<br>Kingsteignton<br>Newton Abbot<br>S. Devon<br>TQ12 3TD         |
| WORCESTER (M73)            | Units 1 & 2<br>Northbrook Close<br>Gregorys Mill Ind. Estate<br>Worcester<br>WR3 8BP         | IPSWICH (M48)                   | Unit 6C<br>Elton Park Business Centre<br>Hadleigh Road<br>Ipswich<br>IP2 0DD | REDRUTH (M36)        | Unit 7D<br>Pool Ind. Estate<br>Wilson Way<br>Redruth<br>Cornwall TR15 3QW                      |
|                            |  | NORWICH (M52)                   | 2b Trafalgar Street<br>Norwich<br>NR1 3HN                                    |                      |  |

# GUARANTEE CONDITIONS

## Standard guarantee conditions

We, Zanussi, undertake that if within 12 months of the date of purchase this Zanussi appliance or any part thereof is proved to be defective by reason only of faulty workmanship or materials, we will, at our option repair or replace the same FREE OF CHARGE for labour, materials or carriage on condition that:

- The appliance has been correctly installed and used only on the electricity supply stated on the rating plate.
- The appliance has been used for normal domestic purposes only, and in accordance with the manufacturer's instructions.
- The appliance has not been serviced, maintained repaired, taken apart or tampered with by any person not authorised by us.
- All service work under this guarantee must be undertaken by a Zanussi Service Force Centre.
- Any appliance or defective part replaced shall become the Company's property.
- This guarantee is in addition to your statutory and other legal rights.

Home visits are made between **8.30am** and **5.30pm** Monday to Friday. Visits may be available outside these hours in which case a **premium** will be charged.

## Exclusions

### This guarantee does not cover:

- Damage or calls resulting from transportation, improper use or neglect, the replacement of any light bulbs or removable parts of glass or plastic.
- Costs incurred for calls to put right an appliance which is improperly installed or calls to appliances outside the United Kingdom.
- Appliances found to be in use within a commercial environment, plus those which are subject to rental agreements.
- Products of Zanussi manufacture which are not marketed by Zanussi.

## European Guarantee

If you should move to another country within Europe then your guarantee moves with you to your new home subject to the following qualifications:

- The guarantee starts from the date you first purchased your product.
- The guarantee is for the same period and to the same extent for labour and parts as exists in the new country of use for this brand or range of products.
- This guarantee relates to you and cannot be transferred to another user.
- Your new home is within European Community (EC) or European Free Trade Area.
- The product is installed and used in accordance with our instructions and is only used domestically, i.e. a normal household.
- The product is installed taking into account regulations in your new country.

Before you move please contact your nearest Customer Care centre, listed below, to give them details of your new home. They will then ensure that the local Service Organisation is aware of your move and able to look after you and your appliance.

|         |           |                      |
|---------|-----------|----------------------|
| France  | Senlis    | +33 (0) 44 62 29 99  |
| Germany | Nuremberg | +49 (0) 911 323 2600 |
| Italy   | Pordenone | +39 (0) 1678 47053   |
| Sweden  | Stockholm | +46 (0) 8 738 79 50  |
| UK      | Slough    | +44 (0) 1753 219897  |

# TECHNICAL SPECIFICATIONS

|            |        |      |    |
|------------|--------|------|----|
| DIMENSIONS | Height | 85   | cm |
|            | Width  | 59.5 | cm |
|            | Depth  | 60   | cm |

|                                     |                   |
|-------------------------------------|-------------------|
| POWER SUPPLY VOLTAGE AND FREQUENCY  | 220-240 V / 50 Hz |
| TOTAL POWER ABSORBED                | 70 W              |
| AVERAGE DAILY UNITS ELECTRICITY (*) | 0.35 kWh          |

GROSS CAPACITY 153 l

NET CAPACITY 150 l

(\*) This figure is based on standard test results in accordance with European Standard EN153. Actual consumption will depend on how the appliance is used and where it is located.

## INSTALLATION

### Positioning

For this appliance to work efficiently, it must not be located where the temperatures will fall below 10°C (50°F) or rise above 32°C (90°F), e.g. conservatories.

For correct operation this appliance must be located in a dry atmosphere, away from heat sources, e.g. cookers, radiators, boilers and direct sunlight.

You should also ensure that air can circulate freely around the back and the top of the cabinet. There should be 100mm (4") between the top of the cabinet and any overhanging kitchen furniture. Alternatively allow 50mm (2") between the top of the cabinet and any overhanging kitchen furniture and a gap of 25mm (1") on either side of the appliance.

Do not obstruct the space underneath. The back of the cabinet may be placed close to the wall but must not touch it. DO NOT install in places with restricted ventilation.

Adjust the level of the appliance by screwing out the adjustable foot, or feet, at the bottom of the cabinet using your fingers.

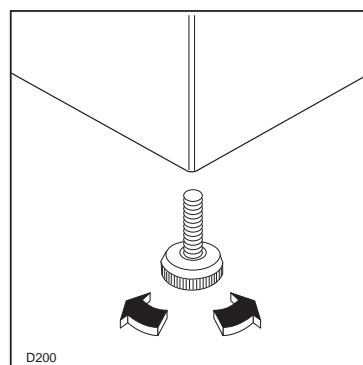
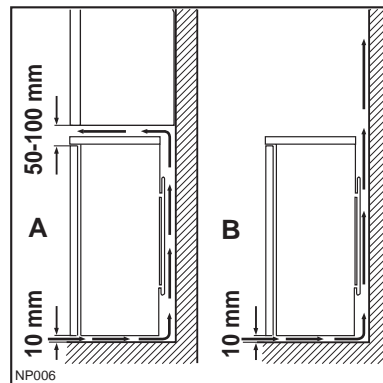

## Door Reversal

Before carrying out the operations described below, pull out the mains plug from the wall socket.

To carry out this reversal go through the following steps:

1. Gently lay the appliance on its back with the top held away from the floor by 5-8 cm (2-3 inches) of packing.
2. Remove the bottom door hinge (5).
3. Remove the door (4) by opening it and pulling it gently downwards to remove it from the top hinge pin (2).
4. Unscrew the top hinge pin (2) from the top hinge (1) and replace it in the opposite hole on the left hand side.
5. Unscrew the foot at the base (6) of the appliance and refit it on the opposite side.
6. Refit the door and the bottom hinge to the left hand side.

**When positioning the bottom hinge blade on the reverse side, the securing screws will require a degree of force when fitting.**

**It is therefore advisable to lubricate the screw tips before starting this operation.**

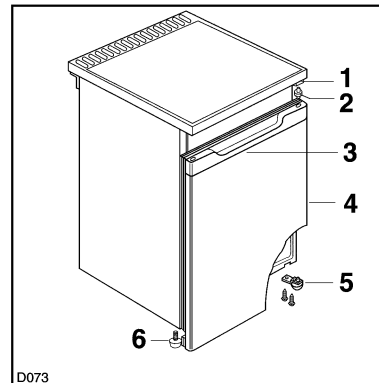

### Important

After completion of the door reversal operation, verify that the door gasket is sealing onto the cabinet. If the ambient temperature is cold (i.e. in Winter), the gasket may not fit perfectly to the cabinet. In that case, wait for the natural fitting of the gasket or accelerate this process by heating up the part involved with a normal hairdryer on a low setting.

# ELECTRICAL CONNECTION



## WARNING:

**THIS APPLIANCE MUST BE EARTHED.**  
The manufacturer declines any liability should this safety measure not be observed.

If the plug that is fitted to your appliance is not suitable for your socket outlet, it must be cut off and the appropriate plug fitted.

Remove the fuse from the cut off plug.

The cut off plug should then be disposed of to prevent the hazard of shocks in case it should be plugged into a 13amp socket in another part of your home.



## Important

The wires in the mains lead are coloured in accordance with the following code:

|                         |                  |
|-------------------------|------------------|
| <b>Green and Yellow</b> | - <b>Earth</b>   |
| <b>Blue</b>             | - <b>Neutral</b> |
| <b>Brown</b>            | - <b>Live</b>    |

If you fit your own plug, the colours of the wires in the mains lead of your appliance, may not correspond with the markings identifying the terminals in your plug, proceed as follows:

Connect the Green and the Yellow (earth) wire to the terminal in the plug which is marked with the letter «E» or the earth symbol  $\oplus$ , or coloured green and yellow.

Connect the blue (neutral) wire to the terminal in the plug which is marked with the letter «N» or coloured black.

Connect the brown (live) wire to the terminal in the plug which is marked with the letter «L» or coloured red.

The plug moulded onto the lead incorporates a fuse. For replacement, use a 13amp BS1362 fuse. Only ASTA or BSI approved fuses should be used.

The plug must not be used if the fuse cover/carrier is lost. The cover/carrier is indicated by the coloured insert at the base of the plug.

A replacement cover/carrier must be obtained from your local Zanussi Service Force Centre.

This appliance complies with the E.E.C. Directive No. 87/308 of 2.6.87 relative to radio interference suppression.



This appliance complies with the following E.E.C. Directive:

- **73/23 EEC** of 19.2.73 (Low Voltage Directive) and subsequent amendments.
- **89/336 EEC** of 3.5.89 (Electromagnetic Compatibility Directive) and subsequent amendments.

**Please ensure that when the appliance is installed it is easily accessible for the engineer in the event of breakdown.**

