

INSTALLATION/OPERATION



110 Series Camclosure® Integrated Camera System With LowLight™ DSS Technology



C2404M-A (4/05)

Contents

Important Safety Instructions	3
Regulatory Notices	4
Welcome	5
Installation	6
Mounting Directly to Surface	6
Wiring Through Base	6
Wiring Through Side Conduit	7
Mounting to a 4S Electrical Box	7
Mounting to a Plaster Ring	7
Install the Camera Module	8
Check Heater Jumper	8
Install and Position the Camera	9
Make Camera Settings	10
Zoom/Focus	10
Digital Slow Shutter (DSS)	10
AGC (Automatic Gain Control)	11
BLC (Back Light Compensation)	11
Vertical Phase Adjustment (24 VAC Operation Only)	11
Varifocal Lens Auto Iris Level Adjustment	11
Install Dome and Trim Ring	12
Specifications	13

Important Safety Instructions

1. Read these instructions.
2. Keep these instructions.
3. Heed all warnings.
4. Follow all instructions.
5. Do not use this apparatus near water.
6. Clean only with dry cloth.
7. Do not block any ventilation openings. Install in accordance with the manufacturer's instructions.
8. Do not install near any heat sources such as radiators, heat registers, stoves, or other apparatus (including amplifiers) that produce heat.
9. Only use attachments/accessories specified by the manufacturer.
10. Use only with the cart, stand, tripod, bracket, or table specified by the manufacturer, or sold with the apparatus. When a cart is used, use caution when moving the cart/apparatus combination to avoid injury from tip-over.
11. Refer all servicing to qualified service personnel. Servicing is required when the apparatus has been damaged in any way, such as power-supply cord or plug is damaged, liquid has been spilled or objects have fallen into the apparatus, the apparatus has been exposed to rain or moisture, does not operate normally, or has been dropped.
12. Installation should be done only by qualified personnel and conform to all local codes.
13. Unless the unit is specifically marked as a NEMA Type 3, 3R, 3S, 4, 4X, 6, or 6P enclosure, it is designed for indoor use only and it must not be installed where exposed to rain and moisture.
14. Use only installation methods and materials capable of supporting four times the maximum specified load.
15. Use stainless steel hardware to fasten the mount to outdoor surfaces.
16. To prevent damage from water leakage when installing a mount outdoors on a roof or wall, apply sealant around the bolt holes between the mount and mounting surface.
17. **CAUTION:** These servicing instructions are for use by qualified service personnel only. To reduce the risk of electric shock do not perform any servicing other than that contained in the operating instructions unless you are qualified to do so.
18. Only use replacement parts recommended by Pelco.
19. The product and/or manual may bear the following marks:



This symbol indicates that dangerous voltage constituting a risk of electric shock is present within this unit.



This symbol indicates that there are important operating and maintenance instructions in the literature accompanying this unit.

CAUTION:
RISK OF ELECTRIC SHOCK. DO NOT OPEN.

REGULATORY NOTICES

This device complies with Part 15 of the FCC Rules. Operation is subject to the following two conditions: (1) this device may not cause harmful interference, and (2) this device must accept any interference received, including interference that may cause undesired operation.

RADIO AND TELEVISION INTERFERENCE

This equipment has been tested and found to comply with the limits of a Class B digital device, pursuant to Part 15 of the FCC Rules. These limits are designed to provide reasonable protection against harmful interference in a residential installation. This equipment generates, uses, and can radiate radio frequency energy and, if not installed and used in accordance with the instructions, may cause harmful interference to radio communications. However there is no guarantee that the interference will not occur in a particular installation. If this equipment does cause harmful interference to radio or television reception, which can be determined by turning the equipment off and on, the user is encouraged to try to correct the interference by one or more of the following measures:

- Reorient or relocate the receiving antenna.
- Increase the separation between the equipment and the receiver.
- Connect the equipment into an outlet on a circuit different from that to which the receiver is connected.
- Consult the dealer or an experienced radio/TV technician for help.

You may also find helpful the following booklet, prepared by the FCC: "How to Identify and Resolve Radio-TV Interference Problems." This booklet is available from the U.S. Government Printing Office, Washington D.C. 20402.

Changes and modifications not expressly approved by the manufacturer or registrant of this equipment can void your authority to operate this equipment under Federal Communications Commission's rules.

This Class B digital apparatus complies with Canadian ICES-003.

Cet appareil numérique de la classe B est conforme à la norme NMB-003 du Canada.

Welcome

Thank you for purchasing Pelco's Camclosure® integrated camera system with LowLight™, DSS (digital slow shutter) technology. Your new ICS110 Series surface mount dome system includes a high resolution, low light, color camera with auto iris and varifocal lens.

The LowLight color camera has extended DSS settings to enhance the low light performance of the camera by automatically adjusting the number of fields of integration. This slows the picture frame rate and increases the camera's sensitivity in low light conditions.

Prior to installation and operation of your new system thoroughly familiarize yourself with the information in this manual.

Installation

MOUNTING DIRECTLY TO SURFACE

WIRING THROUGH BASE

Follow the proceeding steps when feeding wire/cables through the base of the cover and back box:

1. Using the cover as a template, mark one of the large hole positions onto the mounting surface.
2. Cut out the hole in the mounting surface for power and video wiring.
3. Pull video and power wires through the hole in the cover.
4. Attach the cover to the mounting surface (hardware not supplied). Use stainless steel hardware when installing the system outdoors.
5. Connect the video cable.
6. Connect the power wires.
 - Red wire - 24 VAC/12 VDC
 - Black wire - GND

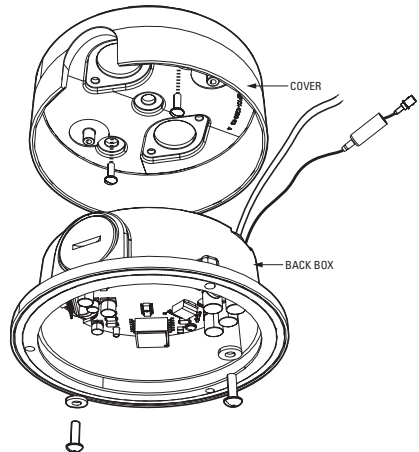

7. Install the back box inside the cover. Rotate and position the back box so that the conduit plug on the side of the box is located on the opposite side (180 degrees) from the notch on the side of the cover. Use the supplied 8-32 x 0.375-inch screws and washers to secure the back box to the cover



NOTE: For vandal-resistant installations, the conduit plug located on the side of the back box should be hidden if it is not used. To hide the conduit plug rotate the back box so that the plug is located on the opposite side (180 degrees) from the notch on the side of cover.

WIRING THROUGH SIDE CONDUIT

Follow the proceeding steps when feeding wire/cables through the side conduit opening of the unit:

1. Attach the cover to the mounting surface (hardware not supplied). Use stainless steel hardware when installing the system outdoors.
2. Remove the conduit plug from the side of the back box.
3. Use a blunt tool to pull the wires and plug, located on the base of the back box into the back box. Insert the black plug (supplied) into the hole in the base of the back box.
4. Install the back box inside the cover. Rotate and position the back box so that the conduit hole on the side of the back box is aligned with the side notch of the cover. Use the supplied 8-32 x 0.375-inch screws and washers to secure the back box to the cover.
5. Install a 0.75-inch (1.91 cm) conduit fitting in the conduit hole of the back box.
6. Connect the video cable.
7. Connect the power wires.
 - Red wire - 24 VAC/12 VDC
 - Black wire - GND

MOUNTING TO A 4S ELECTRICAL BOX

1. Attach the ICS110-AP adapter plate (not supplied) to a 4S box with the two 8-32 x 0.75-inch flat head screws supplied with the adapter plate.
2. Pull the video and power wires into the cover, and then attach the cover to the adapter plate with the three supplied 8-32 x 0.375-inch pan head screws.
3. Connect the video cable.
4. Connect the power wires.
 - Red wire - 24 VAC/12 VDC
 - Black wire - GND
5. Install the back box inside the cover. For vandal-resistant installations, rotate and position the back box so that the conduit plug on the side of the box is located on the opposite side (180 degrees) from the notch on the side of the cover. Use the supplied 8-32 x 0.375-inch screws and washers to secure the back box to the cover.

MOUNTING TO A PLASTER RING

1. Pull video and power wires into the cover, and then attach the cover to a 404 plaster ring. Use the two supplied 6-32 x 0.75-inch flat head screws to attach the cover to a 404 plaster ring.
2. Connect the video cable.
3. Connect the power wires.
 - Red wire - 24 VAC/12 VDC
 - Black wire - GND
4. Install the back box inside the cover. For vandal-resistant installations, rotate and position the back box so that the conduit plug on the side of the box is located on the opposite side (180 degrees) from the notch on the side of the cover. Use the supplied 8-32 x 0.375-inch screws and washers to secure the back box to the cover.

Install the Camera Module

CHECK HEATER JUMPER

The Camclosure is equipped with a heater to defrost the dome. Some installations may not require this heater. If the unit will never be subjected to a frost temperature, you can disable the heater, saving power. To disable the heater, remove the jumper cover from the heater jumper block. It is recommended that the jumper cover be left in the unit by installing it on one of the jumper pins.

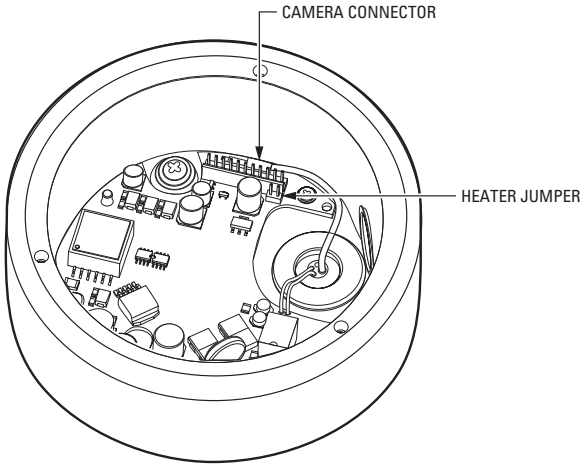

INSTALL AND POSITION THE CAMERA

1. Plug the video connector from the camera into the mating connector inside the back box.
2. Position the camera so that the tab on the camera bracket is pointing out of the enclosure, away from the ceiling or wall. Refer to the following illustrations for proper camera orientation.

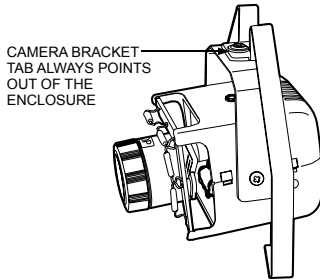

Wall Mounting – The camera bracket tab points out of the enclosure and the top of the camera points up towards the tab.

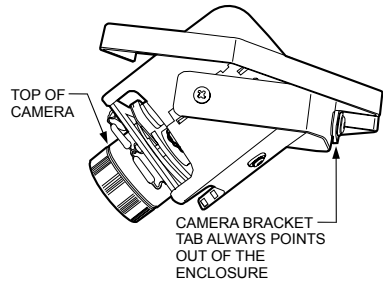

Ceiling Mounting – The camera bracket tab points out of the enclosure and the top of the camera is pointed in the opposite direction.

3. Install the camera bracket. Gently squeeze the bracket, place it against the shoulder inside the back box, and gently release.
4. Turn on power to the camera and monitor.

MAKE CAMERA SETTINGS

CAUTION: Heater elements could be hot! When camera power is on, use caution when adjusting the camera. This applies to all models.

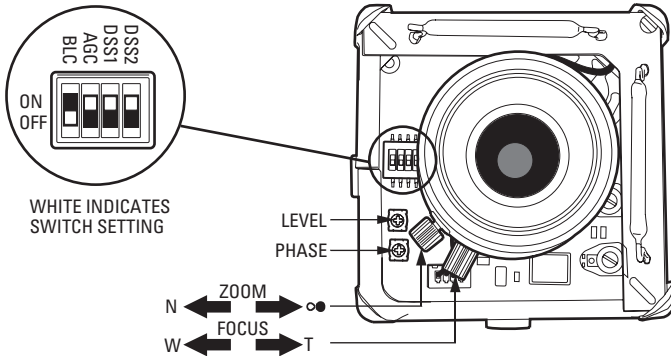

ZOOM/FOCUS

1. Select a field of view by turning the zoom adjustment ring.
2. Tighten the zoom locking screw.
3. Adjust the focus by moving the focus locking screw clockwise/counterclockwise.
4. Tighten the focus locking screw.

DIGITAL SLOW SHUTTER (DSS)

Digital slow shutter slows the picture frame rate and increases the camera sensitivity under low light conditions. Depending on the number of fields of integration, the picture will develop a granular appearance and motion may show some lag, resulting in a stereoscopic effect or streaking on fast moving objects. These effects increase as the number of fields of integration increase.

Available settings include the following:

ON OFF

- DSS2 30 fields of integration maximum (default setting) – 1/2-second scene update rate.
- DSS1
- DSS2 16 fields of integration maximum – 1/4-second scene update rate.
- DSS1
- DSS2 4 fields of integration maximum – 1/15-second scene update rate.
- DSS1
- DSS2 OFF – Disables the DSS mode.
- DSS1

Digital slow shutter automatically adjusts the number of fields of integration depending on the light level of the viewed scene, up to the maximum determined by the switch settings.

AGC (AUTOMATIC GAIN CONTROL)

AGC automatically adjusts the image to compensate for changes in light levels.

ON (Default setting) – Enables the AGC mode.

OFF – Disables the AGC mode.

BLC (BACK LIGHT COMPENSATION)

The BLC (backlight compensation) feature compensates for backlit scenes by enhancing objects in the center of the scene.

OFF (Default setting) – Disables the BLC mode.

ON – Enables the BLC mode. Use this setting if a bright backlight is present and the subject in the center of the picture appears dark or as a silhouette.

VERTICAL PHASE ADJUSTMENT (24 VAC OPERATION ONLY)

When using more than one camera power supply, a brief vertical roll may occur on the monitor when a camera view is switched. To eliminate vertical roll reverse the 24 VAC connections on one camera. If both cameras are connected to the same transformer, this should solve the problem. If reversing the connections does not solve the problem, adjust the phase control by synchronizing, or line-locking, the cameras to one another.

How to Adjust the Phase Control

It may be necessary to have two people in communication when synchronizing the cameras: one person at the camera and another person at the monitor to observe the vertical roll and the effect of any adjustments made at the camera.

To synchronize the cameras:

1. Choose a reference camera to which all other cameras will be phased.
2. Select a camera and synchronize it to the reference camera by turning the phase adjustment control clockwise and/or counterclockwise.
3. Each time an adjustment is made, switch back and forth between the camera you are adjusting and the reference camera. Repeat this process as many times as necessary, until the roll between the cameras is no longer noticeable.
4. Adjust the phase of all other cameras by repeating steps 2 through 3. Always adjust to the reference camera selected in step 1.



NOTE: The preferred method for camera phase adjustment is to use a dual trace oscilloscope to align the vertical synchronization pulses of the reference camera to the selected camera(s).

VARIFOCAL LENS AUTO IRIS LEVEL ADJUSTMENT

To adjust the auto iris level, turn the level adjustment counterclockwise to decrease the brightness level and clockwise to increase the brightness level.

Install Dome and Trim Ring

1. Domes with Liners: Position the viewing window over the lens of the camera.
 - a. Loosen the three Phillip screws located in the dome.
 - b. Insert the blade of a standard screwdriver in one of the adjustment grooves. Move the dome into position.
 - c. Tighten the three Phillip screws to lock the liner in place.
2. Align the screw holes in the trim ring with those in the Camclosure base.
3. Tighten the tamper-resistant screws with the supplied 1/8-inch hollow screwdriver bit.

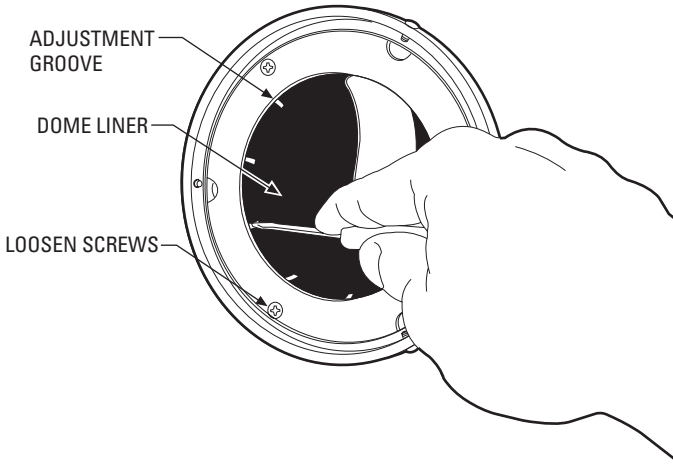

Specifications

Backbox

Electrical

Input Voltage	12 VDC or 24 VAC, $\pm 10\%$, auto-sensing
Power Consumption	13 watts or less
Video Connector	BNC

General

Operating Temperature	-50° to 122°F (-46° to 50°C) De-ices to 25°F (-4°C)
Pan/Tilt Adjustment:Manual	360° pan; 180° tilt
Construction	Aluminum with steel camera mounting bracket and polycarbonate dome
Finish	Light gray polyester powder coat
Environment	Indoor/outdoor
Weight	2.20 lb (1.0 kg)

Camera

Signal System	NTSC/PAL
Imaging Device	1/3-inch interline transfer CCD
Resolution	480 TV lines
Min. Illumination	0.75 lux at 40 IRE, DSS off, f1.6 at wide angle 1.20 lux at 50 IRE, DSS off, f1.6 at wide angle 0.025 lux at 40 IRE, 30 fields of DSS, f1.6 at wide angle 0.040 lux at 50 IRE, 30 fields of DSS, f1.6 at wide angle
Lens	2.6-6.0 mm or 4.0–9.0 mm varifocal, D-mount, f1.6
Synchronize	Adjustable AC line lock/internal, auto select
Iris Control	Electronic/automatic
Signal to Noise	50 dB
AGG	Selectable, ON/OFF
BLC	DIP switch selectable, ON/OFF
Auto Iris Type	DC drive
Shutter	1/60–1/100,000 electronic, auto
Video Level	Adjustable

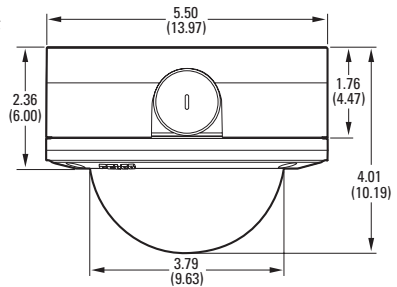

NOTE: VALUES IN PARENTHESES ARE CENTIMETERS; ALL OTHERS ARE INCHES.

(Design and product specifications subject to change without notice.)

PRODUCT WARRANTY AND RETURN INFORMATION

WARRANTY

Pelco will repair or replace, without charge, any merchandise proved defective in material or workmanship **for a period of one year** after the date of shipment.

Exceptions to this warranty are as noted below:

- Five years on FT/FR8000 Series fiber optic products.
- Three years on Genex® Series products (multiplexers, server, and keyboard).
- Three years on Camclosure® and fixed camera models, except the CC3701H-2X, CC3751H-2X, CC3651H-2X, MC3651H-2, and MC3651H-2X camera models, which have a five-year warranty.
- Two years on standard motorized or fixed focal length lenses.
- Two years on Legacy®, CM6700/CM6800/CM9700 Series matrix, and DF5/DF8 Series fixed dome products.
- Two years on Spectra®, Esprit®, ExSite™, and PS20 scanners, including when used in continuous motion applications.
- Two years on Esprit® and WWW5700 Series window wiper (excluding wiper blades).
- Eighteen months on DX Series digital video recorders, NVR300 Series network video recorders, and Endura™ Series distributed network-based video products.
- One year (except video heads) on video cassette recorders (VCRs). Video heads will be covered for a period of six months.
- Six months on all pan and tilts, scanners or preset lenses used in continuous motion applications (that is, preset scan, tour and auto scan modes).

Pelco will warrant all replacement parts and repairs for 90 days from the date of Pelco shipment. All goods requiring warranty repair shall be sent freight prepaid to Pelco, Clovis, California. Repairs made necessary by reason of misuse, alteration, normal wear, or accident are not covered under this warranty.

Pelco assumes no risk and shall be subject to no liability for damages or loss resulting from the specific use or application made of the Products. Pelco's liability for any claim, whether based on breach of contract, negligence, infringement of any rights of any party or product liability, relating to the Products shall not exceed the price paid by the Dealer to Pelco for such Products. In no event will Pelco be liable for any special, incidental or consequential damages (including loss of use, loss of profit and claims of third parties) however caused, whether by the negligence of Pelco or otherwise.

The above warranty provides the Dealer with specific legal rights. The Dealer may also have additional rights, which are subject to variation from state to state.

If a warranty repair is required, the Dealer must contact Pelco at (800) 289-9100 or (559) 292-1981 to obtain a Repair Authorization number (RA), and provide the following information:

1. Model and serial number
2. Date of shipment, P.O. number, Sales Order number, or Pelco invoice number
3. Details of the defect or problem

If there is a dispute regarding the warranty of a product which does not fall under the warranty conditions stated above, please include a written explanation with the product when returned.

Method of return shipment shall be the same or equal to the method by which the item was received by Pelco.

RETURNS

In order to expedite parts returned to the factory for repair or credit, please call the factory at (800) 289-9100 or (559) 292-1981 to obtain an authorization number (CA number if returned for credit, and RA number if returned for repair).

All merchandise returned for credit may be subject to a 20% restocking and refurbishing charge.

Goods returned for repair or credit should be clearly identified with the assigned CA or RA number and freight should be prepaid. Ship to the appropriate address below.

If you are located within the continental U.S., Alaska, Hawaii or Puerto Rico, send goods to:

Service Department
Pelco
3500 Pelco Way
Clovis, CA 93612-5699

If you are located outside the continental U.S., Alaska, Hawaii or Puerto Rico and are instructed to return goods to the USA, you may do one of the following:

If the goods are to be sent by a COURIER SERVICE, send the goods to:

Pelco
3500 Pelco Way
Clovis, CA 93612-5699 USA

If the goods are to be sent by a FREIGHT FORWARDER, send the goods to:

Pelco c/o Expeditors
473 Eccles Avenue
South San Francisco, CA 94080 USA
Phone: 650-737-1700
Fax: 650-737-0933

REVISION HISTORY

Manual #	Date	Comments
C2404M	2/05	Original version.
C2404M-A	4/05	Replaced 8-32 x 0.5-inch screws with 8-32 x 0.375-inch screws per ECO 05-10876.



Worldwide Headquarters
3500 Pelco Way
Clovis, California 93612 USA

USA & Canada
Tel: 800/289-9100
Fax: 800/289-9150
International
Tel: 1-559/292-1981
Fax: 1-559/348-1120

www.pelco.com

ISO9001