

Installation, Start-Up and Service Instructions

CONTENTS

	Page
SAFETY CONSIDERATIONS	1
INSTALLATION	1-10
Step 1 — Provide Unit Support	1
• ROOF CURB	
• ALTERNATE UNIT SUPPORT	
Step 2 — Rig and Place Unit	1
• POSITIONING	
• ROOF MOUNT	
Step 3 — Field Fabricate Ductwork	6
Step 4 — Make Unit Duct Connections	6
Step 5 — Trap Condensate Drain	6
Step 6 — Make Electrical Connections	7
• FIELD POWER SUPPLY	
• FIELD CONTROL WIRING	
Step 7 — Make Outdoor Air Inlet	7
Adjustments	7
• MANUAL OUTDOOR AIR DAMPER	
• OPTIONAL ECONOMIZER	
Step 8 — Install Outdoor Air Hood	10
START-UP	10-13
SERVICE	14-16

Follow all safety codes. Wear safety glasses and work gloves. Use quenching cloth for unbrazing operations. Have fire extinguishers available for all brazing operations.

⚠ WARNING

Before performing service or maintenance operations on unit, turn off main power switch to unit. Electrical shock could cause personal injury.

INSTALLATION

Step 1 — Provide Unit Support

ROOF CURB — Assemble and install accessory roof curb in accordance with instructions shipped with this accessory. Accessory roof curb and information required to field fabricate a roof curb are shown in Fig. 1 and 2. Install insulation, cant strips, roofing and flashing as shown. Ductwork can be installed to roof curb before unit is set in place. Curb should be level. Unit leveling tolerance is $\pm 1/16$ in. per linear ft in any direction. This is necessary to permit unit drain to function properly. Refer to Accessory Roof Curb Installation Instructions for additional information as required.

ALTERNATE UNIT SUPPORT — When the curb cannot be used, support unit with sleepers using unit curb support area. If sleepers cannot be used, support long sides of unit with a minimum of 3 equally spaced 4-in. x 4-in. pads on each side.

Step 2 — Rig and Place Unit — Inspect unit for transportation damage. File any claim with transportation agency. Do not drop unit, keep upright. Use spreader bars over unit to prevent sling or cable damage. Rollers may be used to move unit across a roof. Level by using unit frame as a reference; leveling tolerance is $\pm 1/16$ in. per linear ft in any direction. See Fig. 3 for additional information. Unit weight is shown in Table 1.

Four lifting holes are provided in ends of unit base rails as shown in Fig. 3. Refer to rigging instructions on unit.

POSITIONING — Provide clearance around and above unit for airflow, safety and service access (Fig. 4).

SAFETY CONSIDERATIONS

Installation and servicing of air conditioning equipment can be hazardous due to system pressure and electrical components. Only trained and qualified service personnel should install, repair or service air conditioning equipment.

Untrained personnel can perform basic maintenance functions of cleaning coils and filters and replacing filters. All other operations should be performed by trained service personnel. When working on air conditioning equipment, observe precautions in the literature, tags and labels attached to the unit and other safety precautions that may apply.

Manufacturer reserves the right to discontinue, or change at any time, specifications or designs without notice and without incurring obligations.

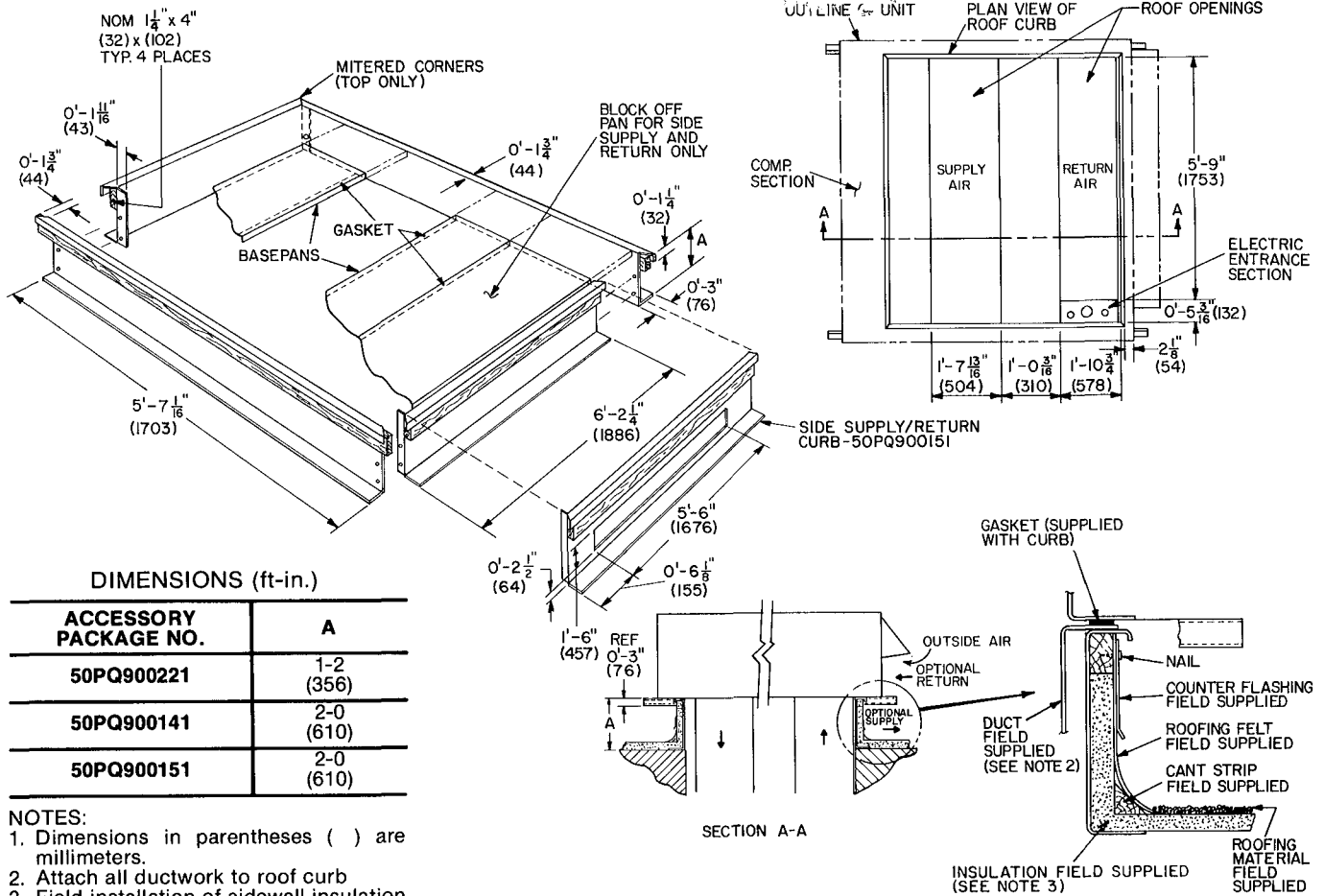

Fig. 1 — Roof Curb Details

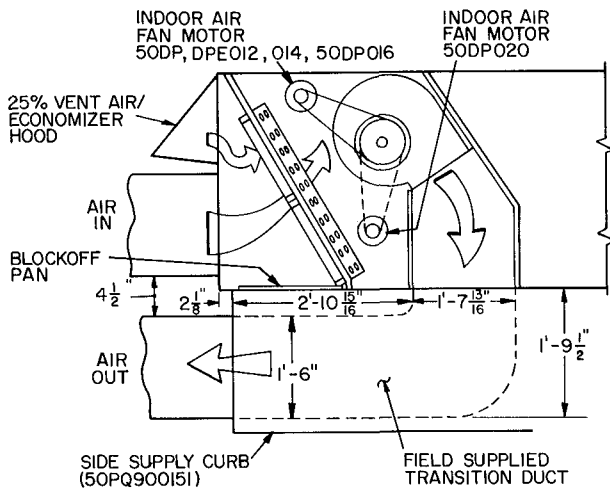
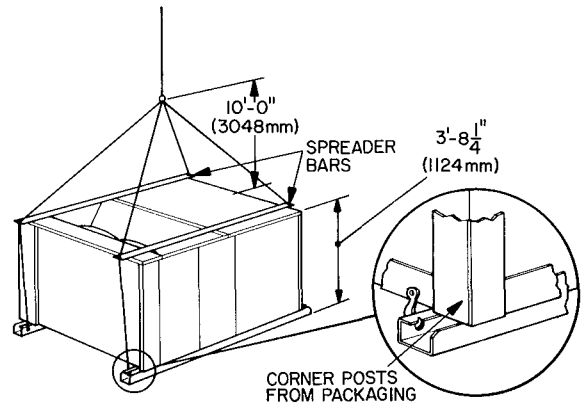

Fig. 2 — Side Supply/Return Curb Details



MODEL	COIL FIN MATERIAL OUTDOOR/INDOOR		
	Al/Al	Cu/Al	Cu/Cu
50DP012	1590	1640	1690
50DPE012	1670	1750	1820
50DP014	1670	1750	1820
50DPE014	1880	1960	2040
50DP016	1880	1960	2040
50DP020	2390	2520	2630

*Includes economizer weight.

NOTE: Rig by inserting hooks into unit base rails as shown. Maintain a distance of 120 in. (3048 mm) from top of unit to eyehook. Use corner post from packaging to protect coil of unit from damage by rigging cable. Use bumper boards for spreader bars.

CAUTION!

All panels must be in place when rigging.

Fig. 3 — Rigging Details

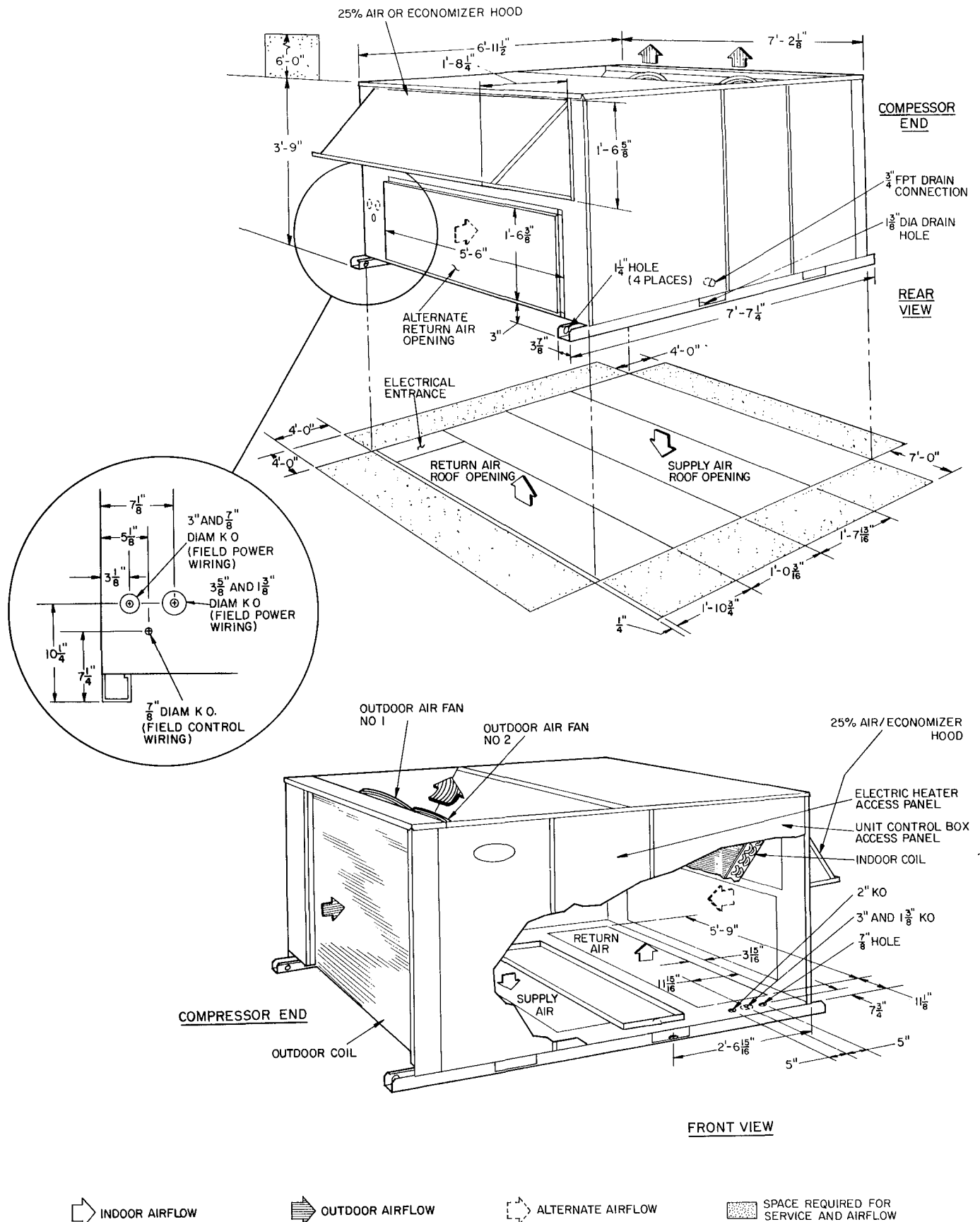

Fig. 4 — Physical Data and Dimensions

→ Table 1a — Physical Data — 50DP,DPE012,014

UNIT SIZE	50DP012	50DPE012	50DP014	50DPE014
OPERATING WEIGHT (lb)				
Unit (Outdoor Coil/Indoor Coil)				
Al/Al	1180	1260	1260	1470
Al/Cu	1230	1340	1340	1550
Cu/Cu	1280	1410	1410	1630
Roof Curb			200	
Economizer			110	
Electric Heat			65	
Alternate Motor and Drive			5	
COMPRESSOR		Hermetic — 2 Cylinders		Semi-Hermetic — 6 Cylinders
Quantity...Type	2 .P64	1 P56, 1 P60	2 .P77	1 .06DA328
Oil (oz)	76 ea	76 ea	76 ea	160
REFRIGERANT			R-22	
Charge (lb) Sys 1*, Sys 2	7.9, 6.6	10.9, 12.5	8.3, 8.4	20.8
REFRIGERANT METERING DEVICE	Capillary Tubes			
Upper Circuit				
Quantity...Length...ID/OD (in.)	7 .35 0.055/0.125	8 .34 0.055/0.125	8 .44 0.065/0.125	6 .25 0.055/0.125 6 .25 0.055/0.125 6 .25 .0.055/0.125
Lower Circuit				
Quantity...Length...ID/OD (in.)	6 .20 .0.055/0.125	7 .20 .0.055/0.125	7 .35 .0.065/0.125	—
OUTDOOR COIL	Copper Tube, Aluminum or Copper Plate Fins			
Rows	2	3	3	3
Fins/in.				
Aluminum	13.6	13.6	13.6	13.6
Copper	12.4	12.4	12.4	12.4
Total Face Area (sq ft)	18.9	18.9	18.9	18.9
OUTDOOR AIR FAN	Propeller Type, Direct Drive			
Nominal Cfm	9000	8000	8000	12,000
Quantity...Diameter (in.)	2 .22	2 .22	2 .22	2 .26
Motor Hp (1075 Rpm)	1/2	1/2	1/2	1
INDOOR COIL	Copper Tube, Aluminum or Copper Plate Fins			
Rows	2	3	3	3
Fins/in.				
Aluminum	14.4	15.6	15.6	14.3
Copper	13.1	14.2	14.2	13.1
Total Face Area (sq ft)	14.7	13.8	13.8	16.5
INDOOR AIR FAN†	Centrifugal, Belt Drive			
Quantity...Size (in.)	2 10x10	2 10x10	2 10x10	2 10x10
Nominal Cfm	4000	4000	5000	5000
Rpm Range	753-1066	805-1093	805-1093	805-1093
Max Allowable Rpm	1550	1550	1550	1550
Motor Pulley Pitch Diameter (in.)	2.4-3.4	2.8-3.8	2.8-3.8	2.8-3.8
Fan Pulley Pitch Diameter (in.)	2.8-3.8	3.4-4.4	3.4-4.4	3.4-4.4
Belt, Quantity...Type...Length (in.)	1 V. 41	1 V. 43	1 V. 43	1 V. 43
Speed Change per Full Turn of Moveable Pulley Flange (Rpm)	62	58	58	58
Moveable Pulley Max Full Turns from Closed Position	63	57	57	57
Factory Setting — Full Turns Open	5	5	5	5
Factory Speed Setting (Rpm)	3.5	3	3.5	3
Motor Hp (Service Factor)	846	920	891	920
	972	1092	1063	1092
	1 (1.25)	2 (1.15)	2 (1.15)	2 (1.15)
	1 1/2 (1.20)	3 (1.15)	3 (1.15)	3 (1.15)
HIGH-PRESSURE SWITCH			428	
Cutout (psig)			320	
Reset (psig)				
LOW-PRESSURE SWITCH (Liquid Line)			27	
Cutout (psig)			60	
Reset (psig)				
AIR INLET SCREENS			2 .20x25x1	
Economizer, Number...Size (in.)			1 .20x20x1	
INDOOR AIR FILTERS (Type)	10% efficient — Disposable Fiberglass			
Number...Size (in.)	2 .16x20x2 4 .16x25x2	2 .16x20x2 4 .16x25x2	2 .16x20x2 4 .16x25x2	2 .20x20x2 3 .16x20x2 2 .16x25x2

*System 1 consists of upper portion of outdoor coil and lower portion of indoor coil

†Units have adjustable standard and alternate drives

→ Table 1b — Physical Data — 50DP016,020

UNIT SIZE	50DP016	50DP020
OPERATING WEIGHT (lb)		
Unit (Outdoor Coil/Indoor Coil)		
Al/Al	1470	1980
Al/Cu	1550	2110
Cu/Cu	1630	2220
Roof Curb		200
Economizer		110
Electric Heat		65
COMPRESSOR	Semi-Hermetic — 6 Cylinders	
Quantity...Type	1 .06DA537	2. 06DA824
Oil (oz)	160	160 ea
REFRIGERANT	R-22	R-22
Charge (lb) Sys 1*, Sys 2	21.2	17.0, 17.0
REFRIGERANT METERING DEVICE	Capillary Tubes	
Upper Circuit		
Quantity...Length...ID/OD (in.)	6 40 0 065/0 125 6 20 .0 055/0 125 6...20 .0 055/0 125	13 25 0 055/0 125
Lower Circuit		
Quantity...Length...ID/OD (in.)	—	13 .25 .0 055/0 125
OUTDOOR COIL	Copper Tubes, Aluminum or Copper Plate Fins	
Rows	3	4
Fins/in.		
Aluminum	13.6	13.6
Copper	12.4	12.4
Total Face Area (sq ft)	18.9	22.2
OUTDOOR AIR FAN	Propeller Type, Direct Drive	
Nominal Cfm	12,000	11,400
Number...Diameter (in.)	2 .26	2 .26
Motor Hp (1075 Rpm)	1	1
INDOOR COIL	Copper Tubes, Aluminum or Copper Plate Fins	
Rows	3	4
Fins/in.		
Aluminum	14.3	14.4
Copper	13.1	13.1
Total Face Area (sq ft)	16.5	17.9
INDOOR AIR FAN†	Centrifugal, Belt Drive	
Quantity...Size (in.)	2 .10x10	2 .12x12
Nominal Cfm	6000	7200
Rpm Range	Std 916-1186 Opt 1158-1428	—
	Pulley A	848
	Pulley B	1060
Maximum Allowable Rpm	1550	1550
Motor Pulley Pitch Diameter (in.)	Std 3 4-4.4 Opt 4 3-5 3	—
	Pulley A	3 2
	Pulley B	4 0
Fan Pulley Pitch Diameter (in.)	6.4	6.6
Belt, Quantity...Type...Length (in.)	1 V . 45	2 .V 45
Speed Change per Full Turn	Std 54	—
of Moveable Pulley Flange (Rpm)	Opt 55	—
Moveable Pulley Max Full Turns from Closed Position	5	—
Factory Setting — Full Turns Open	3 5	—
Factory Speed Setting (Rpm)	Std 970 Opt 1240	—
	Pulley A	848
	Pulley B	1060
Motor Hp (Service Factor)	Std 3 (1.15) Opt —	5 (1 15) —
HIGH-PRESSURE SWITCH		
Cutout (psig)		428
Reset (psig)		320
LOW-PRESSURE SWITCH (Liquid Line)		
Cutout (psig)		27
Reset (psig)		60
AIR INLET SCREENS		
Economizer, Number...Size (in.)		2 20x25x1 1...20x20x1
INDOOR AIR FILTERS (Type)	10% efficient — Disposable Fiberglass	
Number...Size (in.)	2. 20x20x2 3. 16x20x2 2. 16x25x2	4 20x20x2 4 16x20x2

*System 1 consists of upper portion of outdoor coil and lower portion of indoor coil, except for size 020 which is intertwined

†016 unit has *adjustable* standard and alternate drives The 020 unit does not have an alternate drive, but has 2 *non-adjustable* pulleys Pulley A is installed in unit; pulley B is shipped with unit

Step 3 — Field Fabricate Ductwork — Secure all ducts to building structure. Use flexible duct connectors between unit and ducts as required. Insulate and weather-proof all external ductwork, joints and roof openings with flashing and mastic in accordance with applicable codes.

Ducts passing through an unconditioned space must be insulated and covered with a vapor barrier.

A minimum clearance is not required on 50DP, DPE012,014 and 50DP016 units. The 50DP020 units with electric heat require one-in. clearance the first 24 in. of ductwork.

Outlet grilles must not lie directly below unit discharge.

Step 4 — Make Unit Duct Connections — Unit is shipped for through-the-bottom duct connections. Ductwork openings are shown in Fig. 1 and 4. Duct connections are shown in Fig. 5. Field-fabricated concentric ductwork may be connected as shown in Fig. 6 and 7. Attach all ductwork to roof curb and roof curb basepans. Refer to installation instructions shipped with accessory roof curb.

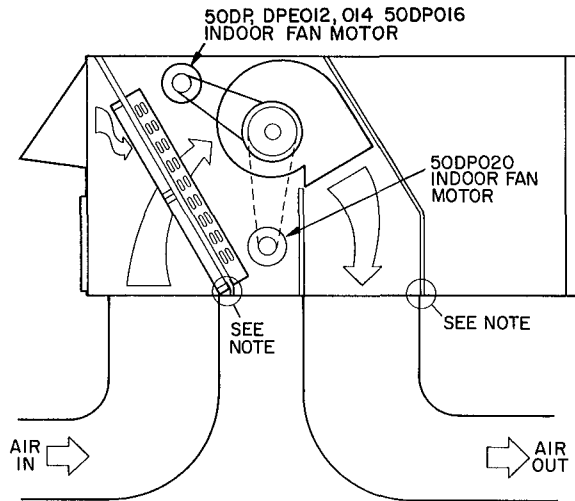

NOTE: Do not drill in this area, damage to basepan may result in water leak.

Fig. 5 — Air Distribution — Through-the-Bottom

Step 5 — Trap Condensate Drain — See Fig. 4 and 8 for drain location. Plug is provided in drain hole and must be removed when unit is operating. One 3/4-in. half coupling is provided inside unit evaporator section for condensate drain connection. An 8-1/2 in. x 3/4-in. diameter and 2-in. x 3/4-in. diameter pipe nipple coupled to standard 3/4-in. diameter elbows provide a straight path down through holes in unit base rails (see Fig. 9). A trap at least 4 in. deep must be used and must be protected against freeze-up.

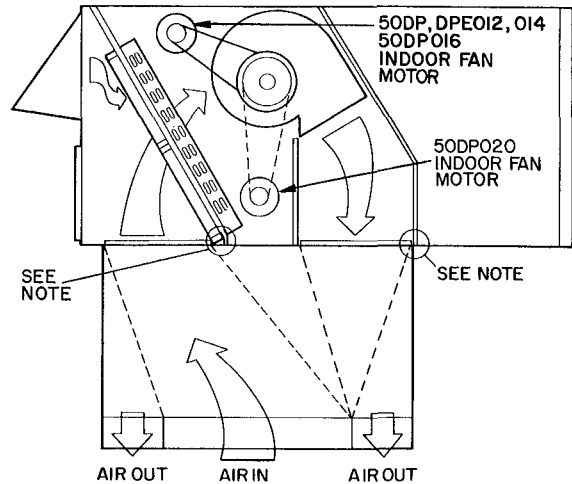

NOTE: Do not drill in this area, damage to basepan may result in water leak

Fig. 6 — Concentric Duct Air Distribution

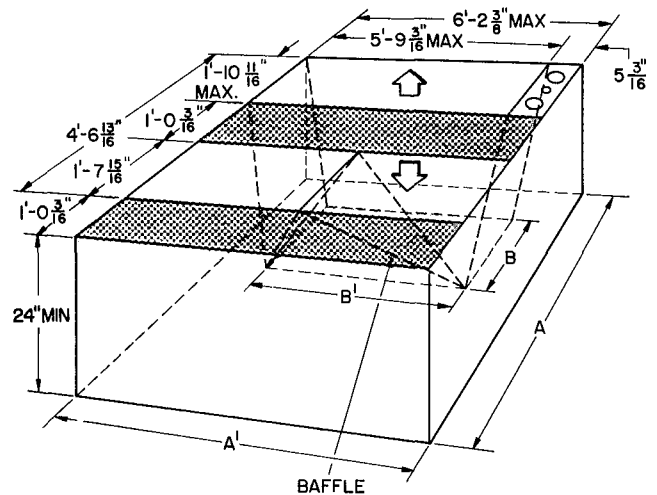

Shaded area indicates block-off panels

NOTE: Dimension A, A1 and B, B1 are obtained from field-supplied ceiling diffuser.

Fig. 7 — Concentric Duct Details

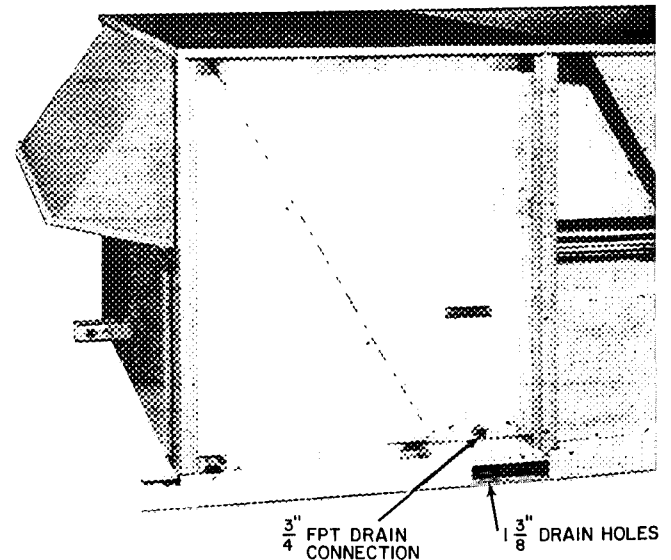

Fig. 8 — Condensate Drain Details

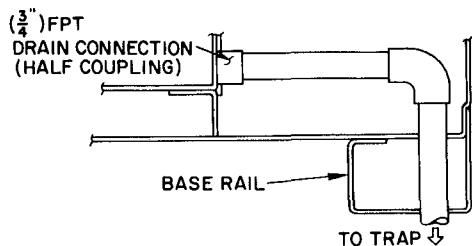

Fig. 9 — Condensate Drain Piping Details

Step 6 — Make Electrical Connections

FIELD POWER SUPPLY — Unit is factory wired for voltage shown on nameplate. Units are provided with terminal block.

When installing units, provide a disconnect per NEC of adequate size (Table 2).

All field wiring must comply with National Electrical Code and local requirements.

Route power lines through control box end panel — or unit basepan — (Fig. 4) to terminal connections as shown on unit wiring diagram and Fig. 10.

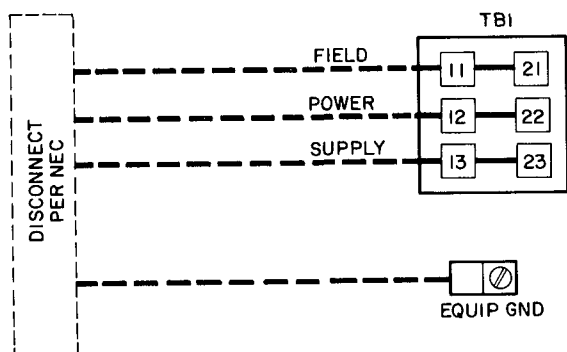

Fig. 10 — Field Power Wiring Connections

Operating voltage to compressor must be within voltage range indicated on unit nameplate. On 3-phase units, voltages between phases must be balanced within 2% and the current must be balanced within 10%.

Use the following formula to determine the % voltage unbalance.

$$\% \text{ Voltage Unbalance} = 100 \times \frac{\text{max voltage deviation from average voltage}}{\text{average voltage}}$$

Example: Supply voltage is 460-3-60.

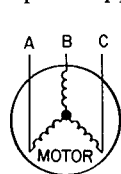

AB = 452 volts
BC = 464 volts
AC = 455 volts

$$\begin{aligned} \text{Average Voltage} &= \frac{452 + 464 + 455}{3} \\ &= \frac{1371}{3} = 457 \end{aligned}$$

Determine maximum deviation from average voltage:

$$(AB) 457 - 452 = 5 \text{ volts}$$

$$(BC) 464 - 457 = 7 \text{ volts}$$

$$(AC) 457 - 455 = 2 \text{ volts}$$

Maximum deviation is 7 volts.

Determine % voltage unbalance:

$$\% \text{ Voltage Unbalance} = 100 \times \frac{7}{457} = 1.53\%$$

This amount of phase unbalance is satisfactory as it is below the maximum allowable 2%.

IMPORTANT: If the supply voltage phase unbalance is more than 2%, contact your local electric utility company immediately.

Unit failure as a result of operation on improper line voltage or excessive phase imbalance constitutes abuse and may cause damage to electrical components. Such operation would invalidate any applicable Carrier warranty.

FIELD CONTROL WIRING — Install a Carrier-approved accessory thermostat assembly according to installation instructions included with accessory. Locate thermostat assembly on a solid wall in the conditioned space to sense average temperature.

Route thermostat cable or equivalent single leads of no. 18 AWG colored wire from subbase terminals through conduit in unit to low-voltage connections as shown on unit label wiring diagram and in Fig. 11.

NOTE: For wire runs up to 50 ft, use no. 18 AWG insulated wire (35 C minimum). For 50 to 75 ft, use no. 16 AWG insulated wire (35 C minimum). For over 75 ft, use no. 14 AWG insulated wire (35 C minimum).

Set heat anticipator settings as indicated in Table 3. Settings may be changed slightly to provide a greater degree of comfort for a particular installation.

Refer to accessory remote control panel instructions as required.

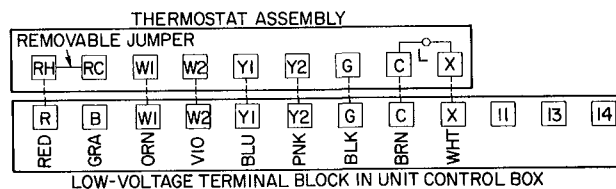

Fig. 11 — Field Control Thermostat Wiring

Step 7 — Make Outdoor Air Inlet Adjustments

MANUAL OUTDOOR AIR DAMPER — All units (except those equipped with a factory-installed economizer) have a manual outdoor air damper to provide ventilation air. Damper can be preset to admit up to 25% outdoor air into return air compartment. To adjust, loosen securing screws and move damper to desired setting then retighten screws to secure damper (Fig. 12).

OPTIONAL ECONOMIZER

Enthalpy Control Setting (location is shown in Fig. 13) — For maximum benefit of outside air, set enthalpy control to the A setting (Fig. 14).

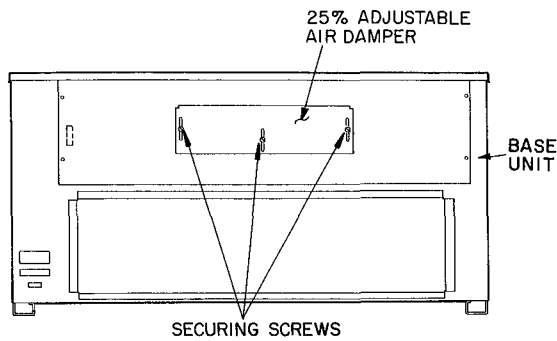

Fig. 12 — 25% Outdoor Air Section Details

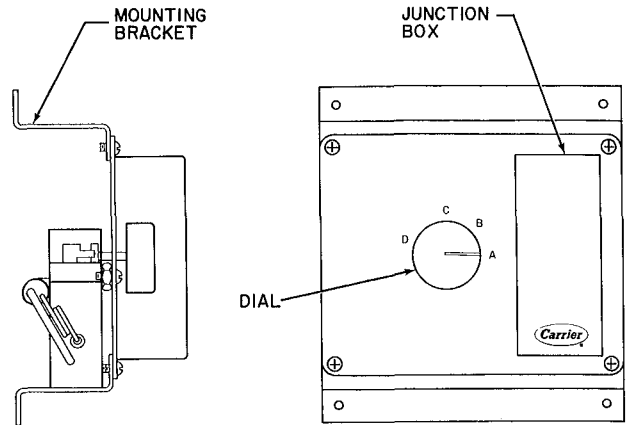

Fig. 14 — Enthalpy Control Assembly

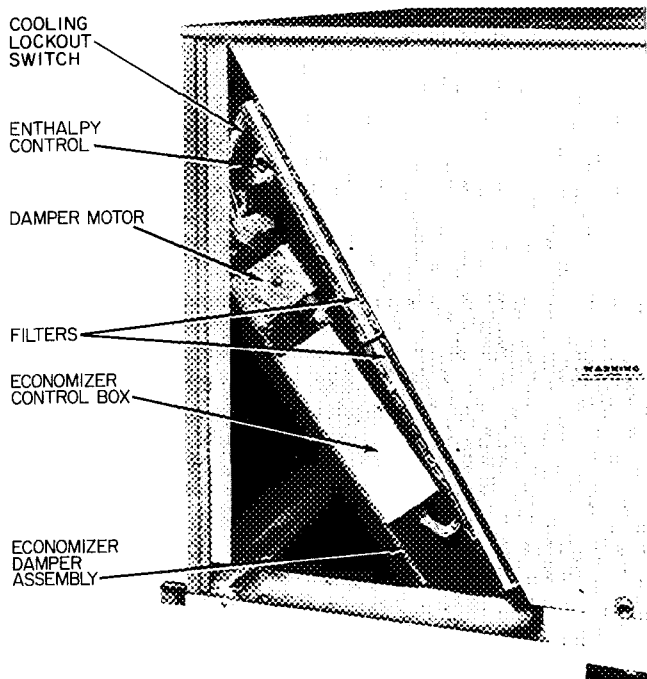

Fig. 13 — Enthalpy Control Location (Economizer Damper Assembly — End View)

Mixed Air Thermostat Setting — Set mixed air thermostat in return air compartment to desired temperature of air delivered to the conditioned space (not less than 35 F or condensation in unit will result).

Damper Vent Position Setting

1. Set fan switch at ON (continuous fan operation) and close night switch if used.
2. Set system selector switch to OFF.
3. Remove cap from vent adjustment screw on damper motor terminal box cover.
4. Turn adjustment screw slowly until dampers assume desired vent position. *Do not manually operate damper motor; damage to motor will result.*

→ Table 2 — Electrical Data

UNIT MODEL	VOLTS-PH-HZ	VOLTAGE RANGE		COMPR		OUTDOOR FAN MOTOR		INDOOR FAN MOTOR		FACTORY-INSTALLED HEATERS		POWER SUPPLY	
		Min	Max	RLA	LRA	Qty	FLA	Hp	FLA	FLA	kW	Min Ckt Amps	MOCP (Amps)
50DP012	208/230-3-60	187	253	24 0 (ea)	136 (ea)	2	3 8	10	4 0	—	—	66/ 66	30/ 30
								15	5 7	—	—	68/ 68	30/ 30
								10	4 0	74/ 82	26/31	98/108	30/ 30
								10	4 0	122	42*	158	175/ 175
								10	4 0	122/135	42/52	158/174	60/ 60
								10	4 0	41/ 45	14/17	66/ 66	30/ 30
								15	5 7	74/ 82	26/31	101/110	30/ 30
								15	5 7	122	42*	160	175
								15	5 7	122/135	42/52	160/176	175/ 200
								15	5 7	41/ 45	14/17	68/ 68	30/ 30
								10	1 8	—	—	31	40
								15	2 6	—	—	32	40
								10	1 8	21	16	31	40
								10	1 8	39	30	51	50
								10	1 8	66	51	85	80
15	2 6	21	16	32	40								
15	2 6	39	30	52	50								
15	2 6	66	51	86	80								
50DP012	460-3-60	414	508	10 5 (ea)	49 (ea)	2	2 5	10	1 4	—	—	23	30
								20	2 7	—	—	24	30
								10	1 4	37	37	48	50
								20	2 7	37	37	50	50
								10	1 4	—	—	23	30
50DP012	575-3-60	518	632	8 3 (ea)	41 (ea)	2	2 1	10	1 4	—	—	23	30
								20	2 7	—	—	24	30
								10	1 4	37	37	48	50
								20	2 7	37	37	50	50
								10	1 4	—	—	23	30

→ Table 2 — Electrical Data (cont)

UNIT MODEL	VOLTS-PH-HZ	VOLTAGE RANGE		COMPR		OUTDOOR FAN MOTOR		INDOOR FAN MOTOR		FACTORY-INSTALLED HEATERS		POWER SUPPLY																	
		Min	Max	RLA	LRA	Qty	FLA	Hp	FLA	FLA	kW	Min Ckt Amps	MOCP (Amps)																
50DPE012	208/230-3-60	187	253	20.9 (compr 1) 20.9 (compr 2)	98 (compr 1) 137 (compr 2)	2	3.8	2.0	7.5	—	—	63/ 63	90/ 90																
								3.0	10.6	—	—	66/ 66	90/ 90																
								2.0	7.5	74/ 82	26/31	102/112	130/125																
								2.0	7.5	122	42*	162	175																
								2.0	7.5	122/135	42/52	162/179	175/200																
								2.0	7.5	41/ 45	14/17	63/ 66	90/ 90																
								3.0	10.6	74/ 82	26/31	106/116	130/125																
								3.0	10.6	122	42*	166	175																
								3.0	10.6	122/135	42/52	166/182	175/200																
50DPE012	460-3-60	414	508	10.4 (compr 1) 10.3 (compr 2)	49 (compr 1) 69 (compr 2)	2	2.5	2.0	3.4	—	—	32	40																
								3.0	4.8	—	—	34	40																
								2.0	3.4	21	16	32	40																
								2.0	3.4	39	30	53	60																
								2.0	3.4	66	51	85	90																
								3.0	4.8	21	16	34	40																
								3.0	4.8	39	30	55	60																
								3.0	4.8	66	51	86	90																
								50DPE012	575-3-60	518	632	9.3 (compr 1) 8.3 (compr 2)	41 (compr 1) 55 (compr 2)	2	2.1	2.0	2.7	—	—	27	35								
3.0	3.9	—	—	29	35																								
2.0	2.7	37	37	50	50																								
3.0	3.9	37	37	52	60																								
50DP014	208/230-3-60	187	253	25.6 (ea)	137 (ea)	2	3.8									2.0	7.5	—	—	73/ 73	90/ 90								
																3.0	10.5	—	—	76/ 76	100/ 100								
																2.0	7.5	74/ 82	26/31	103/113	130/125								
																2.0	7.5	122	42*	156	175								
																2.0	7.5	122/135	42/52	162/179	175/200								
								2.0	7.5	41/ 45	14/17	73/ 73	90/ 90																
								3.0	10.5	74/ 82	26/31	107/116	130/125																
								3.0	10.5	122	42*	160	175																
								3.0	10.5	122/135	42/52	166/182	175/200																
50DP014	460-3-60	414	508	11.6 (ea)	69 (ea)	2	2.5	2.0	3.4	—	—	35	45																
								3.0	4.8	—	—	36	45																
								2.0	3.4	21	16	35	45																
								2.0	3.4	39	30	53	60																
								2.0	3.4	66	51	87	90																
								3.0	4.8	21	16	36	45																
								3.0	4.8	39	30	55	60																
								3.0	4.8	66	51	89	90																
								50DP014	575-3-60	518	632	9.3 (ea)	55 (ea)	2	2.1	2.0	2.7	—	—	28	35								
3.0	3.9	—	—	30	35																								
2.0	2.7	37	37	50	50																								
3.0	3.9	37	37	52	60																								
50DPE014	208/230-3-60	187	253	49.3	191	2	7.7									2.0	7.5	—	—	85/ 85	125/125								
																3.0	10.6	—	—	88/ 88	125/125								
																2.0	7.5	74/ 82	26/31	102/112	125/125								
																2.0	7.5	122	42*	214	225								
																2.0	7.5	122/135	42/52	162/179	175/200								
								2.0	7.5	41/ 45	14/17	85/ 85	125/125																
								3.0	10.6	74/ 82	26/31	106/116	125/125																
								3.0	10.6	122	42*	217	225																
								3.0	10.6	122/135	42/52	166/182	175/200																
50DPE014	460-3-60	414	508	22.1	86	2	3.3	2.0	3.4	—	—	38	50																
								3.0	4.8	—	—	40	50																
								2.0	3.4	21	16	38	50																
								2.0	3.4	39	30	53	60																
								2.0	3.4	66	51	85	90																
								3.0	4.8	21	16	40	50																
								3.0	4.8	39	30	55	60																
								3.0	4.8	66	51	86	90																
								50DPE014	575-3-60	518	632	17.9	69	2	2.6	2.0	2.7	—	—	31	45								
3.0	3.9	—	—	32	45																								
2.0	2.7	37	37	50	50																								
3.0	3.9	37	37	52	60																								
50DP016	208/230-3-60	187	253	61	266	2	7.7									3.0	10.5	—	—	103/103	150/150								
																—	—	74/ 82	26/31	107/116	150/150								
																—	—	122/135	42/52	166/182	175/200								
																—	—	163	56*	217	225								
																—	—	163/180	56/69	217/239	225/250								
								50DP016	460-3-60	414	508	32.0	120	2	3.3	3.0	4.8	—	—	48	70								
																—	—	39	30	55	70								
																—	—	66	51	89	90								
																—	—	96	73	126	150								
50DP016	575-3-60	518	632	25.6	96	2	2.6									3.0	3.9	—	—	38	60								
																—	—	50	49	68	70								
																50DP020	208/230-3-60	187	254	49.3 (ea)	153 (ea)	2	7.7	5.0	16.7	—	—	144/144	175/175
																								—	—	74/ 82	26/31	144/144	175/175
																								—	—	122/135	42/52	174/190	175/200
								—	—	163/180	56/69	225/246	225/250																
								50DP020	460-3-60	414	508	19.9 (ea)	77 (ea)	2	3.3									5.0	7.6	—	—	59	70
																								—	—	39	30	59	70
																								—	—	66	51	93	100
—	—	96	73	130	150																								

 Fuse only; unshaded values indicate fuses or circuit breakers may be used
Compr — Compressor
FLA — Full Load Amps
Hp — Horsepower

LRA — Locked Rotor Amps
MOCP — Maximum Overcurrent Protection
RLA — Rated Load Amps
 *CSA-approved heaters are rated at 208 volts only

Step 8 — Install Outdoor Air Hood — The outdoor air hood is common to 25% air ventilation and economizer. If economizer is used, all electrical connections have been made and adjusted at the factory. Assemble and install hood in the field.

NOTE: The hood top cover, upper and lower filter retainers, hood drain pan and filter support bracket are secured to the top crate above the condenser fans. The screens, hood side panels, remaining section of filter support bracket and all other hardware are in a package located inside the return-air filter access panel (Fig. 15 and 16).

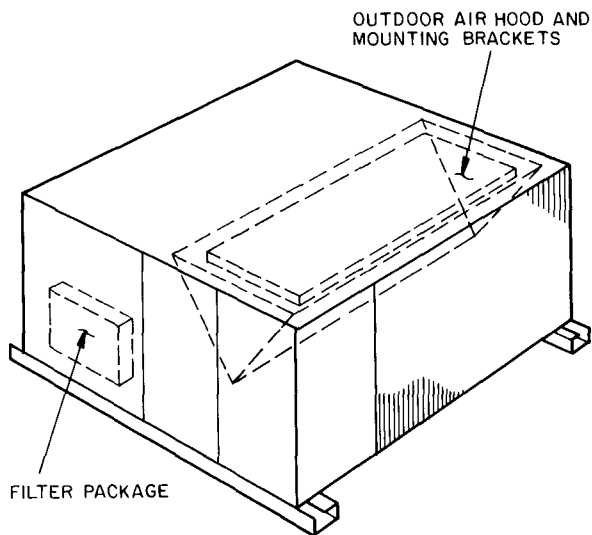

Fig. 15 — Outdoor Air Hood Component Location

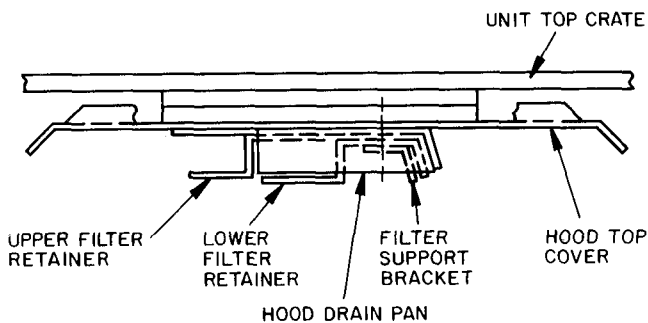

Fig. 16 — Outdoor Air Hood Components

1. Assemble hood top cover, side panels, upper filter retainer and drain pan (Fig. 17).
2. Secure lower filter retainer and support bracket to unit as shown in Fig. 17.
3. Loosen sheet metal screws for base unit top cover located above outdoor air inlet opening.
4. Match notches in hood top cover to unit top cover screws. Insert hood flange between unit top cover flange and unit. Tighten screws.
5. Insert outdoor air inlet screens and spacer in channel created by lower filter retainer and filter support bracket.
6. Attach remaining section of filter support bracket.

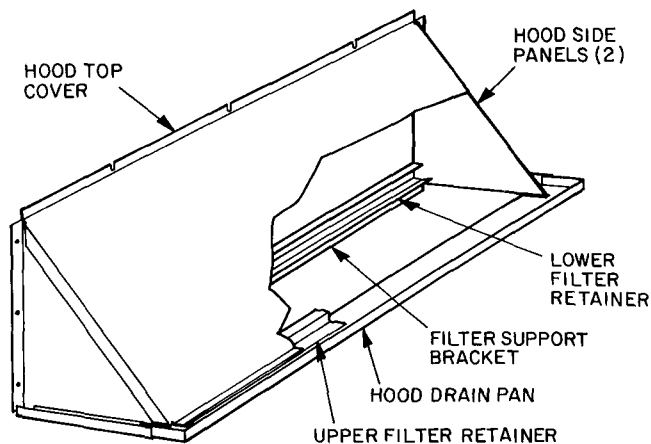

Fig. 17 — Outdoor Air Hood Details

START-UP

Unit Preparation — Check that unit has been installed in accordance with installation instructions and applicable codes.

Compressor Mounting — On 50DP, DPE012 and 50DP014 units, compressors are internally spring mounted. Do not loosen or remove compressor hold-down bolts. On 50DPE014 and 50DP016, 020 units, loosen compressor hold-down bolts until sidewise movement of the washer under each hold-down bolt head can be obtained. Do not loosen completely as bolts are self-locking and will maintain adjustment.

Internal Wiring — Check all electrical connections in unit control boxes; tighten as required.

Refrigerant Service Valves — Each 50DP, DPE012 and 50DP014 unit system has 2 Schrader type service ports, one on suction line and one on compressor discharge line. Be sure that caps on the ports are tight. The 50DPE014 and 50DP016, 020 have one service valve on suction line, one on discharge line and one on liquid line. Be sure valves are open.

Crankcase Heater(s) are energized as long as there is power to the unit.

NOTE: Unit power must be on for 24 hours prior to start-up.

Table 3 — Heat Anticipator Settings

UNIT MODEL	VOLTAGES	kW	STAGE 1	STAGE 2
50DP, DPE012, 014	208-230/3/60	14-17 26-31 42-52	40 40 66	— 40 40
	460/3/60	16 30 51	40 40 40	— 40 .66
50DP016, 020	208-230/3/60	26-31 42-52 56-69	40 .66 66	66 40 .66
	460/3/60	30 51 73	40 40 .66	40 66 .66

Table 4 — Air Quantity Limits

UNIT MODEL	MIN CFM	MAX CFM
50DP,DPE012	3000	5000
50DP,DPE014	3750	6250
50DP016	4500	7500*
50DP020	5400	9000

*Indoor Fan Max Watts = 3000

Indoor Air Fan — Fan belts and pulleys are factory installed. Belts are secured to pulleys with tape. Remove tape and, if required, adjust as described in Service, Indoor Air Fan Adjustment.

50DP020 has 2 non-adjustable pulleys. Pulley A is installed in unit. Pulley B is shipped in cardboard box taped to vestibule below main control box.

Outdoor Air Fans and Motors are factory set. Refer to Service, Outdoor Air Fan Adjustment as required.

Return Air Filters — Check that correct filters are installed in filter tracks. See Table 1. Do not operate unit without return air filters.

Outdoor Air Inlet Screens — Outdoor air inlet screens must be in place before operating unit.

Economizer Section — Remove filter access panel. Check that outdoor air damper is closed and return air damper is open.

Economizer operation and adjustment is described in Start-Up, Economizer Operation; and Service, Economizer Adjustment, respectively.

Base Unit Operation

COOLING — Unit power on. System selector switch at COOL; fan switch at AUTO.; thermostat at a setting below room temperature.

50DPE014 and 50DP016 — Compressor starts unloaded on closure of No. 1 contact in thermostat.

Additional rise in room temperature closes contact No. 2 in thermostat which de-energizes the unloader coil. Compressor is now fully loaded.

Check cooling effects at a setting below room temperature. Check unit charge. Refer to Service, Refrigerant Charge.

Reset thermostat at a temperature above room temperature. Compressor(s) will shut off.

50DP,DPE012 and 50DP014,020 — Upon a rise in room temperature, cooling contact No. 1 in the thermostat closes, energizing the first-stage cooling contactor and the indoor fan contactor. The first-stage compressor, outdoor fan motor and indoor fan motor start and run.

Upon a further rise in room temperature, cooling contact No. 2 in the thermostat closes, energizing the second-stage cooling contactor. The second-stage compressor starts and runs.

To Shut Off Unit — Set system selector switch at OFF position or reset thermostat above room temperature. Units with Signal-LOC™ protection device shut down on any safety trip and thermostat light comes on. Determine reason for safety trip. Restart 50DPE014 and 50DP016, 020 compressor(s) by resetting circuit breaker at unit.

HEATING — Turn on main power to unit. Set system selector switch at HEAT, fan switch at AUTO.; and thermostat at a setting above room temperature. First stage of electric heater elements are energized on closing of heating contact No. 1 in thermostat. On a further fall of room temperature, heater contact No. 2 closes energizing second-stage electric heater elements.

To Shut Off Unit — Set system selector switch at OFF.

VENTILATION AIR CIRCULATION (Continuous Fan) — Unit power on. System selector switch at OFF, HEAT or COOL; fan switch set at ON. Indoor fan contactor is energized through the switch on the thermostat, and the indoor fan runs continuously.

AUTOMATIC CHANGEOVER (with Automatic Changeover Thermostat) — System selector switch set at AUTO. When temperature of conditioned space rises to cooling selector lever setting, unit automatically switches from heating mode to cooling mode. When temperature of the conditioned space falls to the heating selector lever setting, unit automatically changes from cooling mode to heating mode. The thermostat is interlocked so that cooling and heating systems do not operate at the same time.

HEAD PRESSURE CONTROL — All units have fan cycling thermostats which, at 55 F, shut off one outdoor fan motor. This permits unit to operate down to 40 F outdoor air temperature.

Economizer Operation — If unit is equipped with modulating outdoor air control (economizer), it should operate as follows:

COOLING MODE — Indoor and outdoor fans and compressor energize when there is a call for cooling and enthalpy of outdoor air is above enthalpy control setting. The economizer damper moves to VENT position.

Indoor fan starts and economizer damper opens fully on a first-stage call for cooling when enthalpy of outdoor air is below the enthalpy control setting. Compressor remains off.

Compressor is energized and mechanical cooling integrates with economizer cooling upon a second-stage call for cooling. If outdoor air temperature falls below 50 F, cooling lockout switch prevents compressor from operating.

Economizer damper modulates when mixed air temperature is below mixed air thermostat setting.

A freeze protection thermostat (FPT) is located on the indoor coil. It detects ice buildup and turns off the compressor, thus allowing the coil to clear. Once ice melts, the compressor can be re-energized.

HEATING MODE — Outdoor air damper stays at VENT position while indoor air fan runs.

NOTE: If fan switch is at ON position, and room thermostat is satisfied, damper goes to ventilation position.

Variable Volume Units — Units suitable for use with variable volume air handling systems are equipped with 2 electric unloaders on the compressor. The control panel for these units (Fig. 18) consists of a step controller, a proportional thermostat, a 7-day timer and a power switch.

Before starting unit, open compressor service valves and liquid line shutoff valve. Be sure compressor crankcase heaters have been on for 24 hours and that crankcase oil level indicates half full.

CONTROL SEQUENCE CHECKOUT

1. Turn on unit main power supply. Be sure unit is ready to operate.
2. Set variable volume control panel POWER switch at ON.
3. If supply air leaving unit is above 50 F (or other field-set temperature), step controller will operate to de-energize compressor unloader solenoids (compressor loads up) until set temperature is achieved. An interval of 13.5 minutes is required to maximum loading position. Refer to unit label diagram for unloader sequencing. Also see Fig. 19.
4. Step controller, 7-day timer and proportional thermostat are factory set and adjusted. If other settings or changes in adjustment are required, refer to discussion of these items.

SEVEN-DAY TIMER ADJUSTMENT — Factory settings are ON — 6:30 A.M.; OFF — 7:30 P.M. for each of 7 days.

1. On the timer dial face (Fig. 18), loosen the thumb-screws which position the system ON and OFF trippers.
2. Set trippers at desired system ON and OFF time settings and tighten thumbscrews. Skipping a day(s) is accomplished by removing trippers from the dial.
3. Set the timer by turning the dial face *clockwise* until fixed pointer indicates correct day and time. *Do not turn dial face counterclockwise. Do not move fixed pointer.*

PROPORTIONAL THERMOSTAT — The proportional thermostat, Fig. 18, monitors temperature of the conditioned air leaving unit. On signal from the thermostat, sequence motor operates cam switches to load or unload compressor to maintain thermostat setting. Thermostat is factory set at 50 F \pm 6 F but may be reset between 0° F and 100 F as follows:

Temperature Setting — Turn knob on front of case until pointer indicates desired set point temperature. This is the center point of proportional range.

Range Adjustment — Remove cover and turn adjustment wheel until pointer indicates desired range.

If sequencer motor shaft constantly moves back and forth, increase proportional thermostat range (about 5 F at a time) until system is stable.

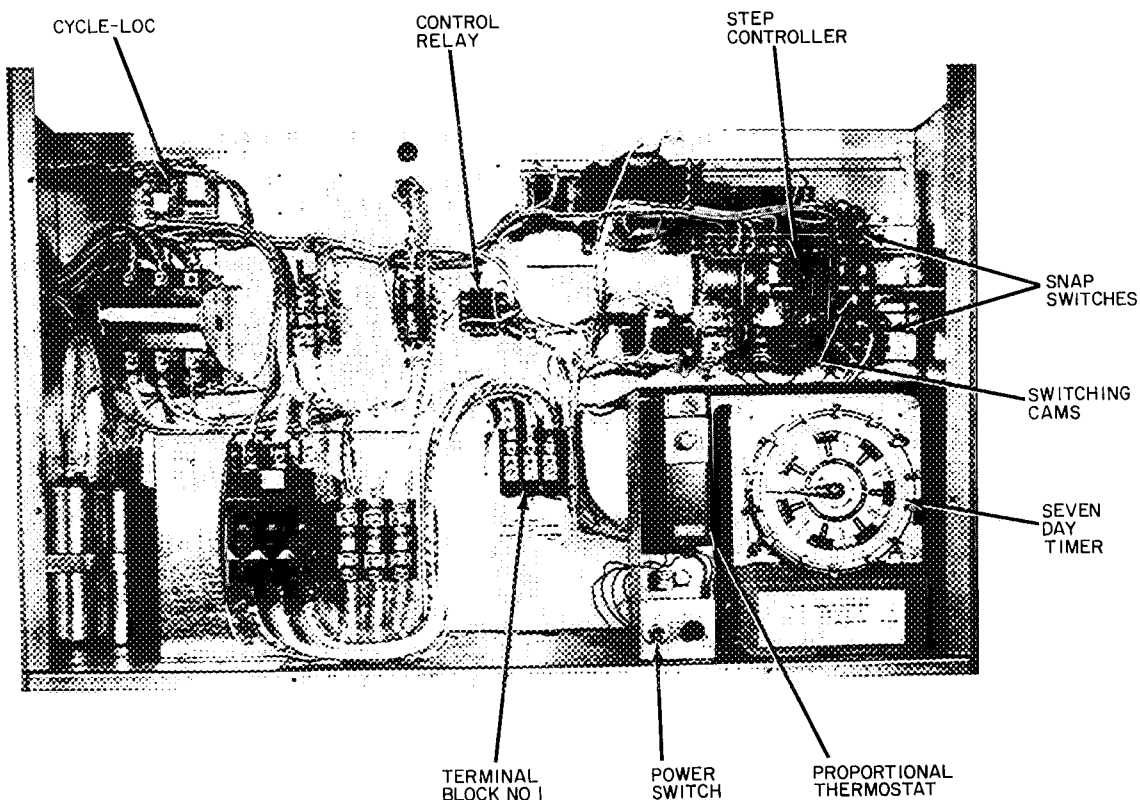

Fig. 18 — Control Panel, Variable Volume Limits

STEP CONTROLLER — The step controller consists of a reversible electric motor which drives a set of cams that activate up to 5 snap-acting switches. Each cam is adjustable to operate at any point on the 160 angular degrees of camshaft rotation. The differential of each system may be adjusted from a minimum of 5 angular degrees to a maximum limited only by the 160 angular degrees of camshaft rotation.

Rotational direction is controlled by the proportional thermostat through the step controller feedback potentiometer and balancing relay.

Determining Switch Settings — Switches are factory set at angular settings as shown in Fig. 19 (also shown on unit label diagram). To reset, if desired, determine angular differential for each switch and between switches. Then determine minimum differential or throttling range of proportional thermostat to provide desired step controller differential or throttling range. This range should be wide enough to prevent rapid cycling from one capacity step to another. Then adjust cams to new settings as required.

Cam Adjustments — The step controller is shipped with cams set to operate switches (i.e. compressor unloaders) as shown in Fig. 19. All switches are closed (compressor unloaded). The shaft is positioned all the way counterclockwise (as viewed from motor end).

Using the following procedure, first adjust all operating points in one direction of motor drive. Then reverse motor direction and adjust switch differentials. Use potentiometer wiper as an approximate indicator of angular adjustments using angular displacement scale mounted on potentiometer back plate. Also see Fig. 20.

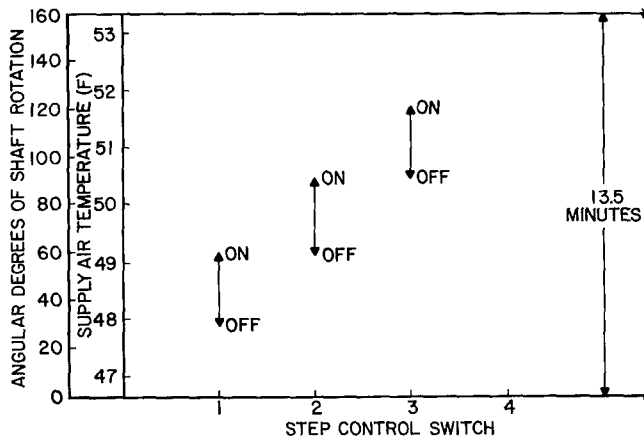

Fig. 19 — Step Controller Sequence

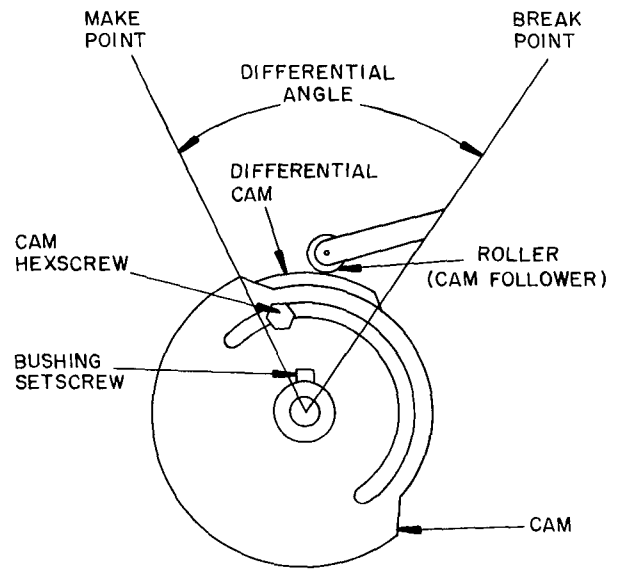

Fig. 20 — Step Controller Cam Adjusting Details (Motor End View)

1. Loosen all bushing setscrews with a 1/16-in. Allen wrench. Loosen all cam hex screws with a 3/16-in. open-end wrench.
If setscrews are not accessible from top of controller, operate motor to rotate cams and bushings by shorting terminals R and B for counterclockwise rotation and terminals R and W for clockwise rotation.
2. Momentarily de-energize motor to permit motor to recycle to start position. Jumper terminals R and W to run motor camshaft to desired position by operating first switch. Stop motor in this position by removing jumper between terminals S and T.
3. Starting with first switch, turn cam clockwise until switch makes an audible "click" as roller moves up cam rise to higher level. This is the operating point. Lock bushing setscrews.
4. Set operating point of each of remaining switches in like manner. Advance motor by momentarily jumpering terminals S and T.
5. Set switch differential by reversing motor (short terminals R and B) and running it to desired break point. Stop motor at this point by de-energizing power at L1 (POWER switch off). Start at last switch and progress to first switch.
Move differential cam clockwise so that roller is on high part of cam. Be sure that switch is at make position. To check this, manually lift roller assembly to make switch. Move differential cam counterclockwise until roller drops to low level of cam. At this point, switch should break. Lock the hex screw.
6. Check settings by performing Control Sequence Checkout.
7. If 115-volt to step controller is de-energized, timer recycles to start point when power is restored.

SERVICE

⚠ WARNING

Before performing service or maintenance operations on unit, turn off main power switch to unit. Turn off accessory heater power switch if applicable. Electrical shock could cause personal injury.

Cleaning — Inspect unit interior at beginning of each heating and cooling season or as operating conditions require. Remove unit top panel and/or side panels for access to unit interior.

INDOOR COIL — Clean with a commercial coil cleaner.

OUTDOOR COIL — Clean outdoor coil annually or as required by location or outdoor air conditions. Inspect coil monthly — clean as required.

CONDENSATE DRAINS — Check and clean each year at start of cooling season. In winter, keep drains and traps dry or protect against freeze-up.

FILTERS — Clean or replace at start of each heating and cooling season, or more often if operating conditions require. Refer to Table 1 for type and size.

OUTDOOR AIR INLET SCREENS — Clean screens with steam or hot water and a mild detergent. Do not use throwaway filters in place of screens.

Lubrication

COMPRESSORS — Each compressor is charged with correct amount of oil at the factory.

FAN SHAFT BEARINGS — No lubrication required. Bearings are permanently lubricated.

FAN MOTOR BEARINGS — No lubrication of outdoor fan or indoor blower motors are required for first 5 years of operation. Annually thereafter, clean and repack bearings with a suitable bearing grease.

Indoor Air Fan Adjustment — Fan motor pulleys are factory set for speed shown in Table 1. The 50DP020 units have fixed pulleys. Fan speed can be adjusted only by changing the pulley. To change fan speed on 50DP, DPE012,014 and 50DP016:

1. Shut off unit power supply.
2. Loosen belt by loosening fan motor mounting plate nuts.
3. Loosen movable pulley flange setscrew (see Fig. 21).
4. Screw movable flange toward fixed flange to increase speed and away from fixed flange to decrease speed. Increasing fan speed increases load on motor. Do not exceed maximum speed specified in Table 1. See Table 4 for air quantity limits.

5. Set movable flange at nearest keyway of pulley hub and tighten setscrew. (See Table 1 for speed change for each full turn of pulley flange.)

To align fan and motor pulleys, loosen fan pulley setscrews and slide fan pulley along fan shaft. Make angular alignment by loosening motor from mounting plate.

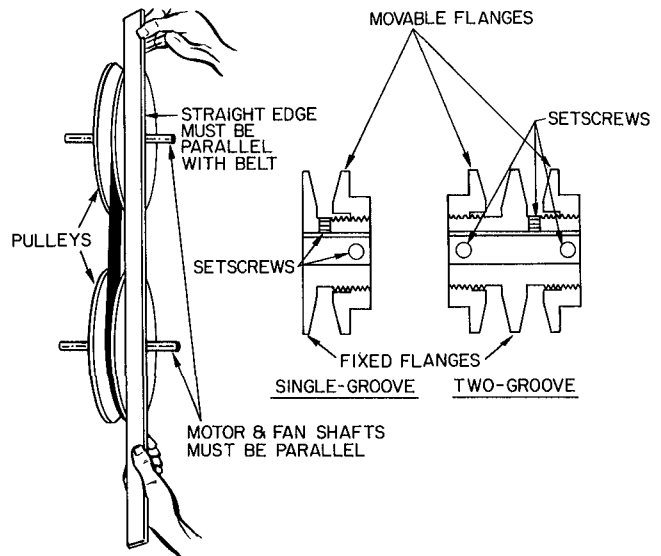

Fig. 21 — Indoor Air Fan Pulley Adjustment (50DP, DPE012,014 and 50DP016)

To Adjust Belt Tension — Loosen fan motor pivot bolts. Move motor mounting plate up or down for proper belt tension (1/2-in. deflection with one finger) and tighten pivot bolts. Adjust lock bolt and nut on mounting plate to secure in fixed position.

Outdoor Air Fan Adjustment (Fig. 22) — Shut off unit power supply. Remove fan top grille assembly and loosen fan hub screws. Adjust fan height on unit using a straight edge placed across the fan orifice. Tighten setscrews and replace rubber hubcap to prevent hub from rusting to motorshaft. Fill hub recess with permagum if rubber hubcap is missing.

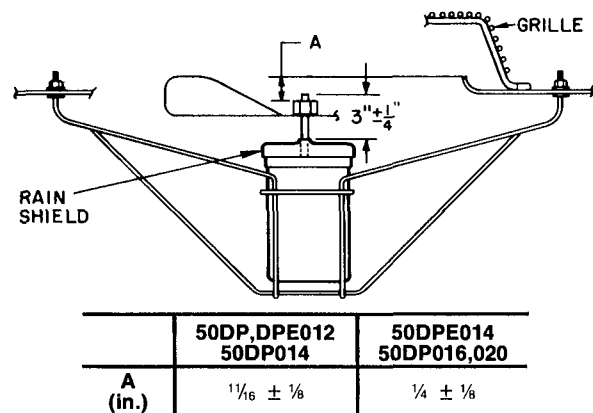

Fig. 22 — Outdoor Air Fan Adjustment

Economizer Adjustment

1. Set enthalpy control at its highest setting. If outdoor temperature is above 70 F, perform the following: install jumper between enthalpy control terminals 1 and 2 (red and yellow wires).
2. Set system selector switch at COOL and set cooling selector lever at lowest setting. (Cooling mode may be simulated by removing thermostat wires from terminals Y1 and Y2 [if used] and installing jumper between Y1 and R.)
3. Set mixed air thermostat (MAT.) at lowest setting. Outdoor air damper goes to fully open position (indoor air damper closes).
4. Set mixed air thermostat at highest setting. Outdoor air damper goes to fully closed position (indoor air damper opens).
5. Adjust mechanical linkage for correct positioning if necessary. If cooling was simulated in 2, remove jumper and reconnect thermostat wire(s).

Power Failure — Dampers do not have a spring return. In event of power failure, dampers remain in position until power is restored. *Do not manually operate damper motor.*

50DP020 Indoor Air Fan Motor Removal

NOTE: To remove belts only, follow steps 1 - 4.

1. Remove filter and supply air section access panels. Remove center post (Fig. 4).
2. Loosen adjusting nuts A and E, Fig. 23.
3. Push motor away from indoor coil to zero adjustment. Tighten nut A.
4. Remove belts from pulleys.
5. Remove holddown screws at B and C. Loosen screw at D.
6. Holding motor and pulley securely, slide motor mount assembly out of unit along slide tracks.

NOTE: To reinstall motor, reverse above procedure.

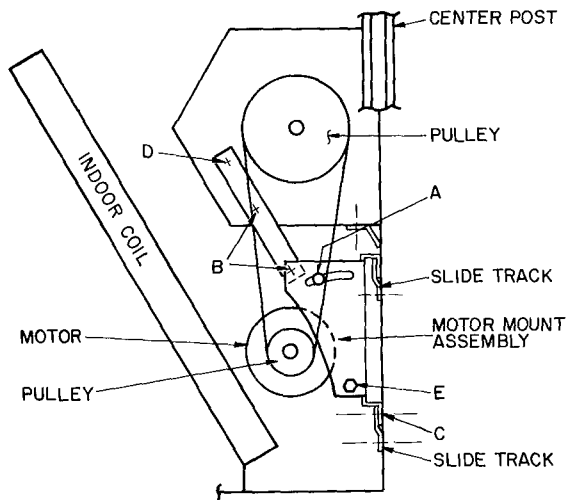

Fig. 23 — 50DP020 Indoor Fan Motor Section

Refrigerant Charge — Amount of refrigerant charge is listed on unit nameplate and in Table 1. Refer to Carrier Standard Service Techniques Manual, Chapter 1, Refrigerants.

Unit panels must be in place when unit is operating during charging procedure.

NO CHARGE — Use standard evacuating techniques. After evacuating system, weigh in the specified amount of refrigerant. (Refer to Table 1.)

LOW CHARGE COOLING — Using appropriate cooling charging chart, Fig. 24, 25, 26 or 27, add refrigerant until conditions of the chart are met. Note that charging charts are different from ones normally used. Charts are based on charging units to correct superheat for various operating conditions. An accurate pressure gage and temperature sensing device are required. Connect temperature sensing device to service port on suction line and insulate it so that outdoor ambient temperature does not affect reading. Indoor air cfm must be within normal operating range of unit.

TO USE COOLING CHARGING CHART — Take outdoor ambient temperature and read the suction pressure gage. Refer to chart to determine correct suction temperature. If suction temperature is high, add refrigerant. If suction temperature is low, carefully blow some of the charge. Recheck suction pressure as charge is adjusted.

Example: Fig. 24 — 50DP012

Outdoor Temperature 75 F
Suction Pressure 65 psig
Suction Temperature should be 62 F
(Suction Temperature may vary ± 5 F.)

If Chargemaster® charging device is used, temperature and pressure readings must be accomplished using appropriate charging chart.

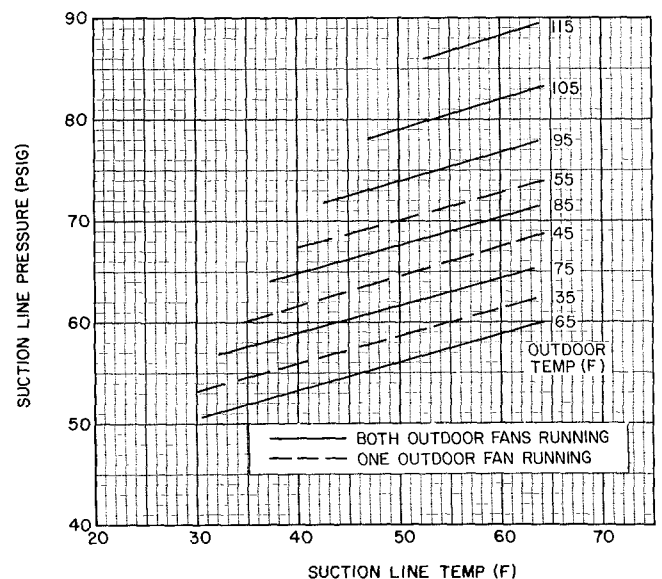

Fig. 24 — Cooling Charging Chart — 50DP012

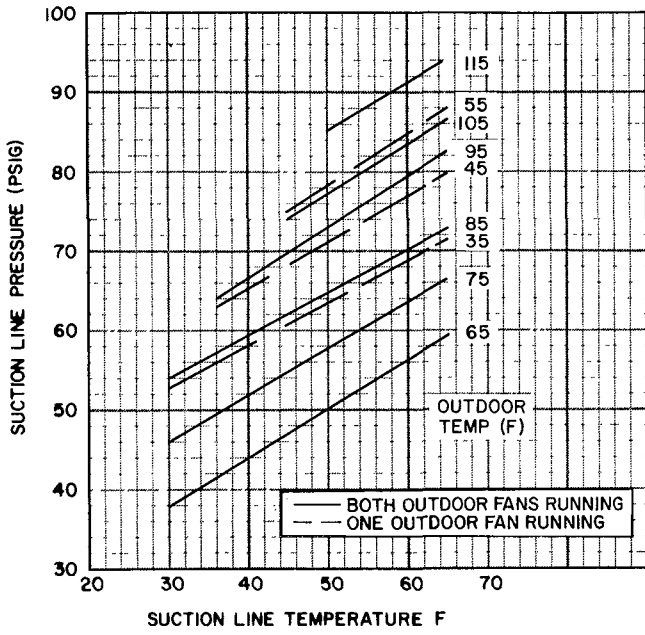

Fig. 25 — Cooling Charging Chart — 50DPE012, 50DP014

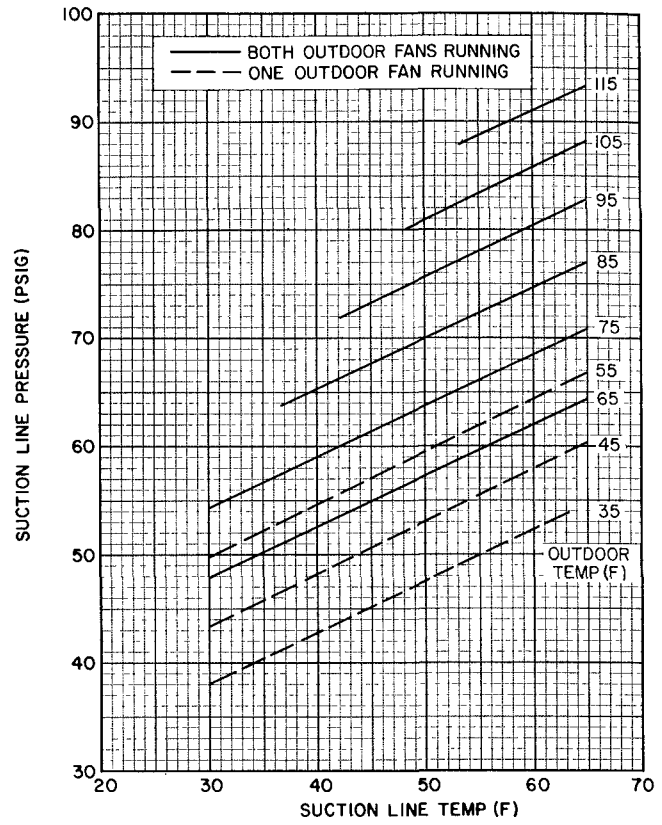

Fig. 26 — Cooling Charging Chart — 50DPE014, 50DP016

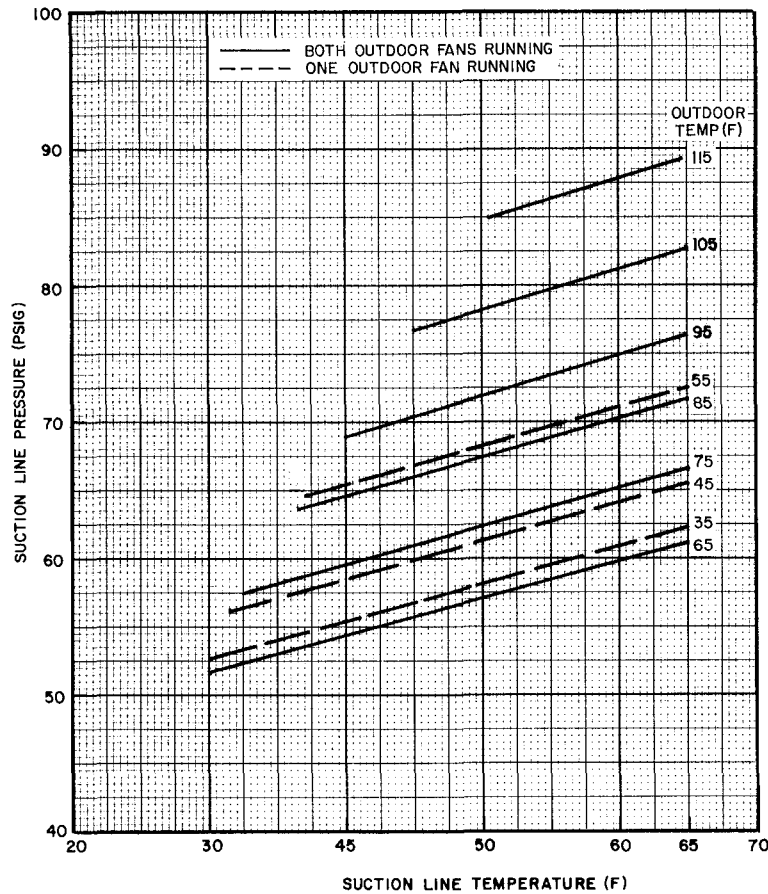

Fig. 27 — Cooling Charging Chart — 50DP020

Manufacturer reserves the right to discontinue, or change at any time, specifications or designs without notice and without incurring obligations.