

Helpdesk / Technical Support Details

Swann Technical Support

All Countries E-mail: tech@swannsecurity.com
Telephone Helpdesk

USA toll free
1-800-627-2799

(Su, 2pm-10pm US PT)
(M-Th, 6am-10pm US PT)
(F 6am-2pm US PT)

USA Exchange & Repairs
562-777-2551
(M-F, 9am-5pm US PT)

AUSTRALIA toll free
1300 138 324

(M 9am-5pm AUS ET)
(Tu-F 1am-5pm AUS ET)
(Sa 1am-9am AUS ET)

NEW ZEALAND toll free
0800 479 266
INTERNATIONAL
+61 3 8412 4610

See <http://www.worldtimeserver.com> for information on time zones and the current time in Melbourne, Australia compared to your local time.

Warranty Information

Swann Communications USA Inc.
12636 Clark Street
Santa Fe Springs CA 90670
USA

Swann Communications PTY. LTD.
Building 4, 650 Church Street,
Richmond, Victoria 3121
Australia

Swann Communications warrants this product against defects in workmanship and material for a period of one (1) year from it's original purchase date. You must present your receipt as proof of date of purchase for warranty validation. Any unit which proves defective during the stated period will be repaired without charge for parts or labour or replaced at the sole discretion of Swann. The end user is responsible for all freight charges incurred to send the product to Swann's repair centres. The end user is responsible for all shipping costs incurred when shipping from and to any country other than the country of origin.

The warranty does not cover any incidental, accidental or consequential damages arising from the use of or the inability to use this product. Any costs associated with the fitting or removal of this product by a tradesman or other person or any other costs associated with its use are the responsibility of the end user. This warranty applies to the original purchaser of the product only and is not transferable to any third party. Unauthorized end user or third party modifications to any component or evidence of misuse or abuse of the device will render all warranties void.

By law some countries do not allow limitations on certain exclusions in this warranty. Where applicable by local laws, regulations and legal rights will take precedence.

 **Swann**
© Swann Communications 2009

 **Swann™**
Advanced security made easy™

plug&playsecurity

Compact Indoor Security Camera Night Vision 16ft / 5m

PNP-50™



Operating Instructions

SW211-HTY
www.swannsecurity.com

SR211-HTY-10006-270409

■ FCC Verification:

NOTE: This equipment has been tested and found to comply with the limits for Class B digital device, pursuant to part 15 of the FCC Rules. These limits are designed to provide reasonable protection against harmful interference in a residential installation. This equipment generates, uses and can radiate radio frequency energy and, if not installed and used in accordance with the instructions, may cause harmful interference to radio or television reception, which can be determined by turning the equipment off and on, the user is encouraged to try to correct the interference by one or more of the following measures:

- Reorient or relocate the receiving antenna
- Increase the separation between the equipment and the receiver
- Connect the equipment into an outlet on a circuit different from that to which the receiver is connected
- Consult the dealer or an experienced radio/TV technician for help

■ IMPORTANT NOTE: Prohibition against eavesdropping

Except for the operations of law enforcement officers conducted under lawful authority, no person shall use, either directly or indirectly, a device operated pursuant to the provisions of this Part for the purpose of overhearing or recording the private conversations of others unless such use is authorized by all of the parties engaging in the conversation.

■ WARNING: Modifications not approved by the party responsible for compliance could void user's authority to operate the equipment.

■ IMPORTANT SAFETY INSTRUCTIONS:

- Make sure product is fixed correctly and stable if fastened in place
- Do not operate if wires and terminals are exposed

Problem: I can't see the camera on my TV.

Solution: Ensure the camera is plugged in and the TV or VCR is tuned to the correct input channel.

Problem: The image is too far away.

Solution: Change the lens to the larger telephoto lens for a zoomed in image. Unscrew the attached lens and replace with telephoto lens.

Problem: The BNC Extension Cable will not connect to my TV.

Solution: Connect the BNC to RCA adapter to the end of the Extension Cable and plug into the TV.

Problem: On my Swann DVR, Video Loss appears where my camera should be.

Solution: Check the Extension cable is securely connected to the camera and check the connection is secure on the back of the DVR. Also ensure the camera has power by trying a second power outlet.

Technical Specifications

■ Video

Image Sensor	1/3" Colour Super CMOS
Video Quality	400 TV Lines
Number of Effective Pixels	NTSC: 510 x 492 / PAL: 628 x 582
Signal / Noise Ratio	> 50dB
Electronic Shutter	1/60 - 1/15,000 NTSC / 1/50 - 1/15,000 PAL
White Balance	Automatic
Gain Control	Automatic
Backlight Compensation	Yes
Day/Night Mode	Colour during the day / Switches to B&W at night
Minimum Illumination	0 Lux (IR on)
Lens	4mm
Viewing Angle	90 degrees

■ General

Indoor/Outdoor	Indoor Only
Operating Power	DC 12V
Operating Temperature	0°C ~ 45°C / 32°F ~ 113°F
Body Construction	Heavy duty plastic
Dimensions - Camera & Stand	4.25" x 2.75" x 1.75" / 108mm x 69mm x 44mm
Weight - Camera & Stand	4.2oz / 125g

Viewing the Camera on Your TV or VCR

■ Viewing the PNP-50 on a TV

After connecting the PNP-50 Camera directly to your TV and powering it on as described on page 4, tune the TV to the correct input channel.

On your TV's remote control, the input button is usually labelled as Input, Source, AV, Channel 0, AUX etc.*

■ Viewing and Recording the PNP-50 on a VCR

Connect the PNP-50 into an available input channel on your VCR in the same manner as the TV connection listed on page 4. Turn on your VCR and TV as if you were about to play a VCR tape.

On your VCR's remote control, find the input button with is usually labelled as L1, L2, Input, Source, AV, Channel, 0, AUX etc.* Insert a tape and push record to record the camera.

*Consult the TV or VCR instruction manual for details about changing input channels

Tips & Suggestions

Never aim the camera directly at the sun as it may damage the sensor

Test all connections and ensure the camera is working correctly prior to permanent installation

Install cameras high enough or out of reach to avoid tampering

Place Security Stickers in a visible location to alert potential thieves they are being monitored

Mix real cameras with dummy cameras to give the impression of increased security coverage

Purchase a Swann DVR to record multiple cameras simultaneously and easily monitor your property.

Place cameras in high traffic areas such as doorways to maximise security

Use only the included Power Supply and do not modify or cut wires

Table of Contents

Before You Begin	2
Table of Contents	3
Package Contents	3
Connection Guide	4-5
Viewing the Camera on Your TV or VCR	6
Tips & Suggestions	6
Troubleshooting Guide	7
Helpdesk / Technical Support Details	8
Warranty Information	8

Package Contents

- PNP-50 Security Camera with Stand
- Extension Cable
- Power Adapter
- Operating Instructions
- Security Stickers
- Mounting Hardware



Connection Guide

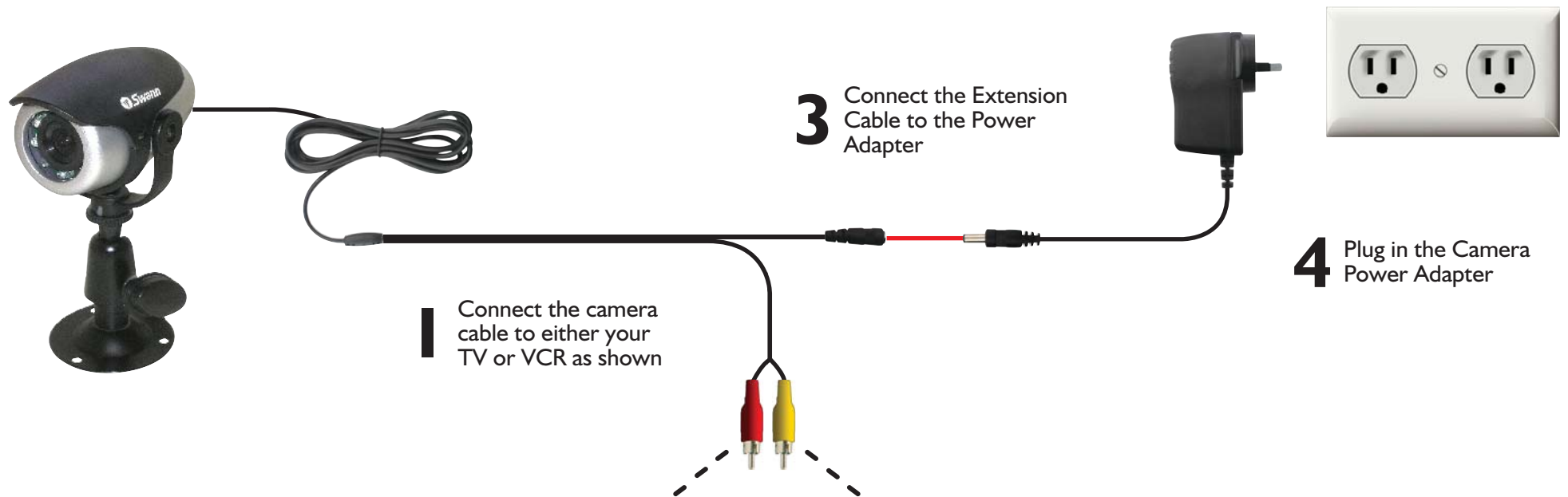

2A. Connect to VCR (Optional)

i Connect the Camera cable to the Input on the back of the VCR

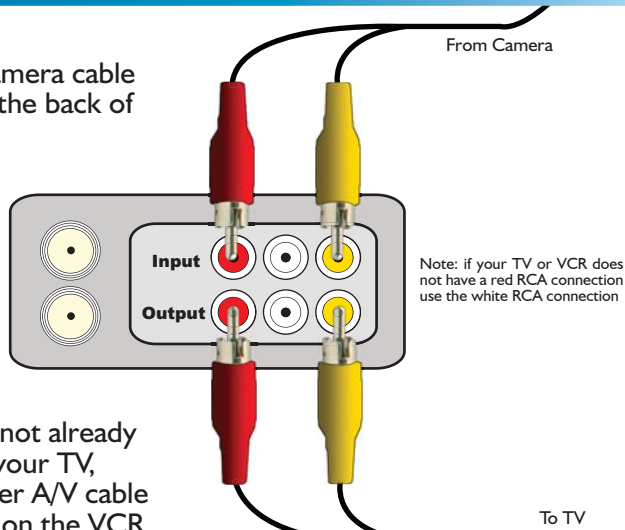

ii If your VCR is not already connected to your TV, connect another A/V cable to the Output on the VCR

2B. Connecting to TV

i Connect the A/V Cable to a TV Input

