

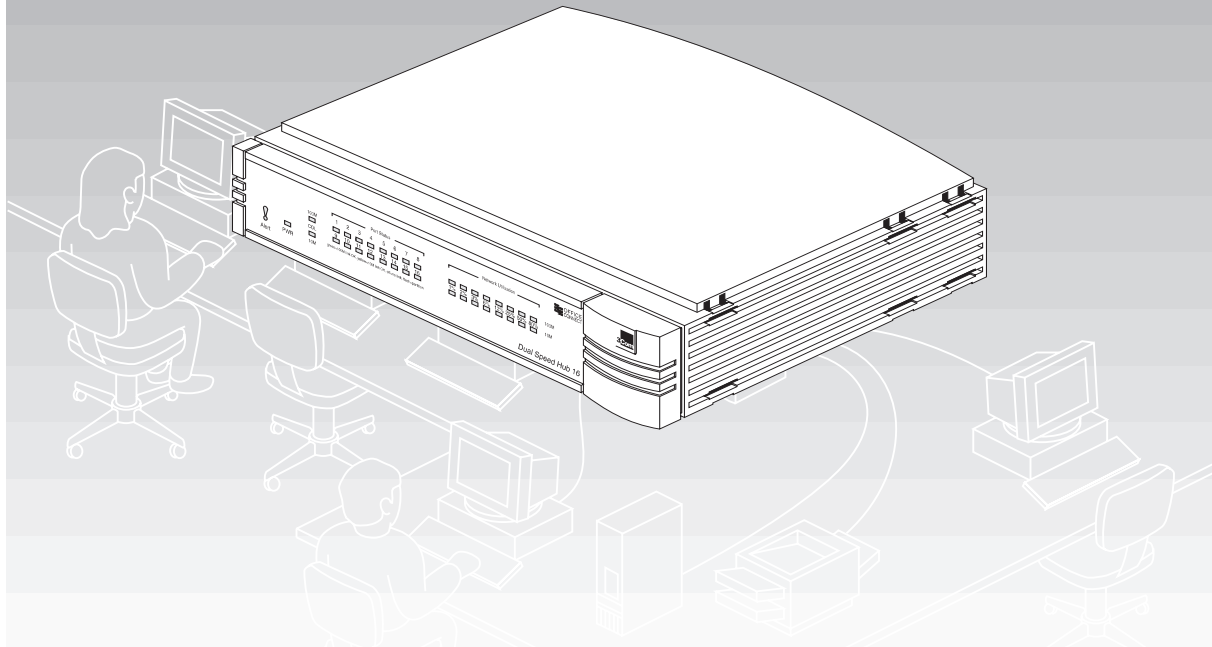

# OFFICECONNECT<sup>®</sup> DUAL SPEED HUB 16

## 3C16751

### USER GUIDE



Part No.  
DUA1675-1AAA01

Published  
August 1998

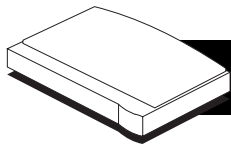

## INTRODUCTION

Welcome to the world of networking with 3Com<sup>®</sup>.

In the modern business environment, communication and sharing information are crucial. Computer networks have proved to be one of the fastest modes of communication. The OfficeConnect<sup>®</sup> product range from 3Com brings the power of computer networks to the small office.

The OfficeConnect Dual Speed Hub 16 is an easy-to-use Class II hub (repeater) with 16 10/100BASE-TX ports. It allows you to set up a network with both Ethernet (10Mbps) and Fast Ethernet (100Mbps) workstations and other devices (a Class II hub can be connected to another Fast Ethernet hub, a Class I hub cannot).

*When referring to the OfficeConnect Dual Speed Hub 16, this guide uses the term 'Hub'.*

Each port on the Hub can be connected to either a 10BASE-T (Ethernet) or a 100BASE-TX (Fast Ethernet) device. The port senses the speed of the connected equipment and operates at the appropriate speed.

If you wish to extend an existing Ethernet network into Fast Ethernet, adding a Dual Speed Hub 16 can offer a more cost-effective migration path than adding both a 100Mbps hub and a 10/100Mbps switch.

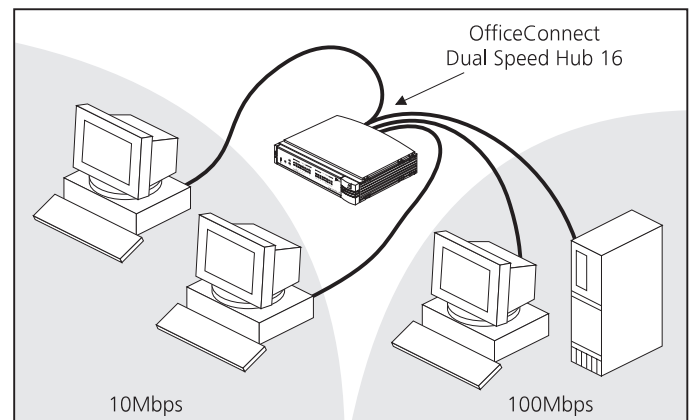

Small Network with OfficeConnect Dual Speed Hub 16

The Hub is ideal for use with other OfficeConnect products. The OfficeConnect product range is compact and attractively designed for desktop use, and neatly stacks together with clips. For further information, refer to the "OfficeConnect Product Range" sheet that accompanies the Hub.

This guide helps you get the most out of your Hub.

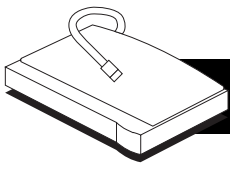

# CREATING YOUR NETWORK

- Alert LED**  
*orange*  
 Off when the Hub is operating correctly. Lit for a short period of time after power on, for self test. If the LED is continuously lit, there may be a problem. Refer to the "Problem Solving" section.
- Power LED**  
*green*  
 Indicates that the power supply to the Hub is present.
- Collision LEDs**  
*yellow*  
 Flash each time a collision is detected on the Hub's 100Mbps or 10Mbps segment. Collisions are a normal part of network operation.
- Port Status LEDs**  
*green (100Mbps link) / yellow (10Mbps link)*  
 If the LED is on, the link between the port and the next piece of network equipment is OK. If the LED is off, nothing is connected, or the connected device is switched off, or there is a problem with the connection (refer to the "Problem Solving" section). If flashing, the port is partitioned, possibly due to a network loop.
- Network Utilization LEDs**  
*green / yellow / orange*  
 (top row: 100Mbps; bottom row: 10Mbps)  
 Indicate how much the 100Mbps and 10Mbps segments of your network are being used.

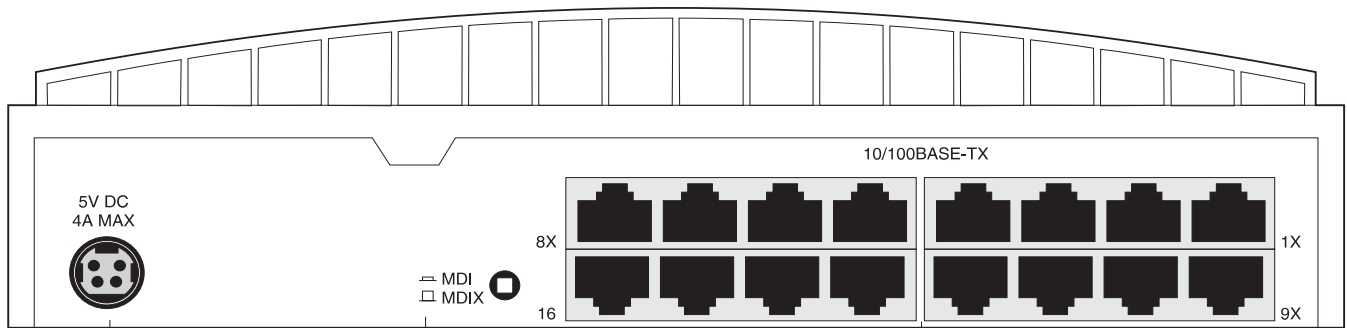
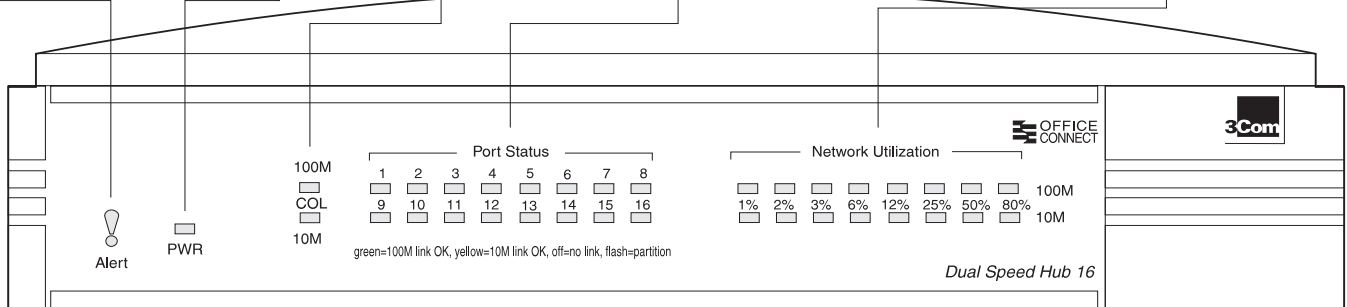

- Power Adapter socket**  
 Only use the power adapter that is supplied with the OfficeConnect Dual Speed Hub 16. Do not use any other adapter.
- MDI/MDIX switch**  
 Affects the operation of port 16. If you are connecting another hub to port 16, set to MDI (in), otherwise set to MDIX (out). Refer to the "Connecting Another OfficeConnect Hub" section.
- Sixteen 10/100BASE-TX ports**  
 Use suitable TP cable with RJ45 connectors. You can connect the Hub to any workstation or other equipment that has a 10BASE-T or 100BASE-TX port. Each port is capable of autosensing for 10Mbps or 100Mbps operation.

## Networking Terminology

- A Network** is a collection of workstations (for example, IBM-compatible PCs) and other equipment (for example, printers), connected for the purpose of exchanging information or sharing resources. Networks vary in size; some are within a single room, others span continents.
- A Local Area Network (LAN)** is a network, usually in an office, that spans no more than a single site.
- Ethernet** is a type of LAN, referring to the technology used to pass information around the network. It operates at 10Mbps (megabits per second).
- Fast Ethernet** is a type of LAN that runs up to 10 times faster than standard Ethernet. It operates at 100Mbps.
- 10BASE-T** is the name given to the Ethernet protocol that runs over **Twisted Pair (TP)** cable at 10Mbps.
- 100BASE-TX** is the name given to the Fast Ethernet protocol that runs over **Twisted Pair (TP)** cable at 100Mbps.

A **Network Loop** occurs when two pieces of network equipment are connected by more than one path.

A **Segment** is the length of cable connected to a port.

**Packets** are the units of information your workstations and other equipment send to each other over the network. A **Frame** is the data part of the packet and can be **Unicast** (sent to a single device), **Multicast** (sent to multiple devices), or **Broadcast** (sent to all devices).

**Bandwidth** refers to the amount of network traffic the network can hold at any one time (information capacity) measured in **bits per second (bps)**. Workstations or applications that use the network heavily are referred to as using high bandwidth (these are usually users who do a lot of graphical or multi-media work across the network). Fast Ethernet has a higher bandwidth than Ethernet, so it can cope with larger amounts of traffic, which results in faster operation.

In a **Half Duplex** link, information can flow in either direction, but not in both directions simultaneously.

## Before You Start

Your OfficeConnect Dual Speed Hub 16 comes with:

- One power adapter for use with the Hub
- One power cord
- A Warranty Registration card for you to fill out and return
- Four rubber feet
- Four stacking clips
- An OfficeConnect Product Range sheet
- An OfficeConnect Network Assistant CD-ROM
- This guide

### Workstation Connections

To connect workstations or other equipment (such as servers) to your Hub, you need:

- 1 One 10BASE-T, 10/100BASE-TX, or 100BASE-TX adapter card for each workstation. 3Com produce a range of easy to install network adapters, which provide your workstation with a suitable connection.
- 2 One suitable TP cable for each workstation.

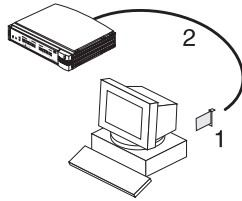

**i** In order to comply with the 10BASE-T standard, ports designed for workstation connections have been marked with the graphical symbol 'X'. This denotes a crossover in the port's internal wiring, for example 1X, 2X, 3X...

You also need a network operating system running on your workstations.

### Twisted Pair (TP) Cables

To connect your workstations and other equipment to the Hub, use 'straight-through' TP cables with RJ45 connectors (all OfficeConnect products use RJ45 type connectors). A 'straight-through' cable is one where each pin of one connector is connected to the same pin of the other connector.

Cables can be shielded (screened) or unshielded; we recommend that you use shielded cable. Cables used for 100BASE-TX or 10/100BASE-TX connections must be data grade (Category 5).

Your supplier should stock suitable cables.

The maximum length of a single cable is 100m (328ft). Refer to "Fast Ethernet (100Mbps) Configuration Rules" on page 5 for further information on cable lengths in a 100Mbps network.

### Hub Connections

To connect other OfficeConnect units to your Hub, you need one suitable TP cable for each unit.

## Using the Rubber Feet and Stacking Clips

The four self-adhesive rubber feet prevent your Hub from sliding around on your desk. Stick the feet to the marked areas at each corner of the underside of your Hub.

The four stacking clips are used for neatly and securely stacking your OfficeConnect units together. **You can stack up to four units. Small units must be stacked above large units.** To stack your units, secure the clips on one side and then on the other. Use the following method to secure one side:

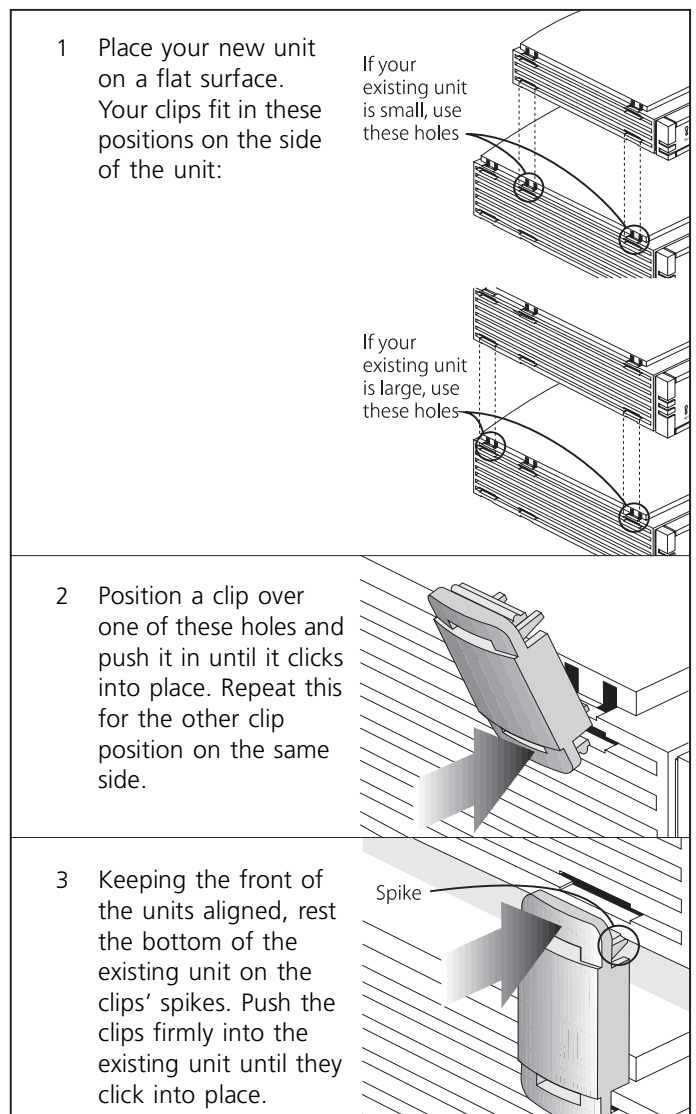

Repeat these steps to secure the other side.

To remove a clip, hold the units firmly with one hand and hook the first finger of your other hand around the back of the clip. Use reasonable force to pull it off.



Wall mounting screw hole guide  
142 mm (5.6 in)



## Positioning Your OfficeConnect Hub

When installing your Hub, ensure:

- It is out of direct sunlight and away from sources of heat.
- Cabling is away from power lines, fluorescent lighting fixtures, and sources of electrical noise such as radios, transmitters and broadband amplifiers.
- Water or moisture cannot enter the case of the unit.
- Air flow around the unit and through the vents in the side of the case is not restricted. We recommend you provide a minimum of 25mm (1in.) clearance.

## Wall Mounting the OfficeConnect Hub



**CAUTION:** Only wall mount single units. Do not wall mount stacked units.

There are two slots on the underside of the Hub which are used for wall mounting. You can mount the unit with the LEDs facing upwards or downwards, to suit your needs.



**i** When wall mounting the unit, ensure that it is within reach of the power outlet.

You need two suitable screws. Ensure that the wall you are going to use is smooth, flat, dry and sturdy. Make two screw holes which are 142mm (5.6in.) apart. Use the guide at the top of this page to mark the position of the holes. Fix the screws into the wall, leaving their heads 3mm (0.12in.) clear of the wall surface.

Remove any connections to the unit and locate it over the screw heads. When in line, gently push the unit on to the wall and move it downwards to secure. When making connections, be careful not to push the unit up and off the wall.

## Connecting Workstations and Other Equipment to Your Hub



**WARNING:** Please read the 'Important Safety Information' section carefully before you install or remove the unit.

**WARNHINWEIS:** Bitte lesen Sie den Abschnitt 'Wichtige Sicherheitsinformationen' sorgfältig durch, bevor Sie das Gerät installieren oder ausbauen.

**AVERTISSEMENT:** Veuillez lire attentivement la section "Consignes importantes de sécurité" avant d'installer ou de retirer l'appareil.



**CAUTION:** The equipment connected to the Hub must be set to operate in auto-negotiate or half duplex mode.

Connecting workstations and other equipment to your Hub is easy. To connect a workstation to any of the Hub's ports, use a 'straight-through' TP cable. Refer to "Twisted Pair (TP) Cables" on page 3 for further information.



**i** If you are using port 16 to connect a workstation, ensure the MDI/MDIX switch is set to MDIX (out).

TP cables are very easy to use. To connect a cable, simply slot the connector into the appropriate RJ45 port. When the connector is fully in, its latch locks it in place. To disconnect the cable, push the connector's latch in and remove it.

The Hub detects all port connections, so you can start using your network immediately. If you need more ports, simply add another OfficeConnect hub.

## Connecting Another OfficeConnect Hub

You may wish to connect another OfficeConnect hub to your Dual Speed Hub 16. Alternatively, you may wish to add your Hub to an existing 10Mbps network. When extending your network, you should be aware of the configuration rules given below.

**i** If you connect two Dual Speed Hub 16 units directly together, the link between them operates at 100Mbps.

### Fast Ethernet (100Mbps) Configuration Rules

The Dual Speed Hub 16 is a Class II hub. You can connect directly two Class II Fast Ethernet hubs (Class I Fast Ethernet hubs cannot be connected directly to other Fast Ethernet hubs). The total length of cable (A + B + C below) between two workstations, or between a workstation and a non-repeater piece of equipment (such as a switch), must not exceed 205m (672ft). Each cable (A, B, or C) must not exceed 100m (328ft).

3Com recommends that the cable (B) between the Fast Ethernet hubs is no longer than 5m (16.4ft). This allows the maximum hub-to-workstation cable length (A or C) of 100m (328ft) to be used, as shown in the example.

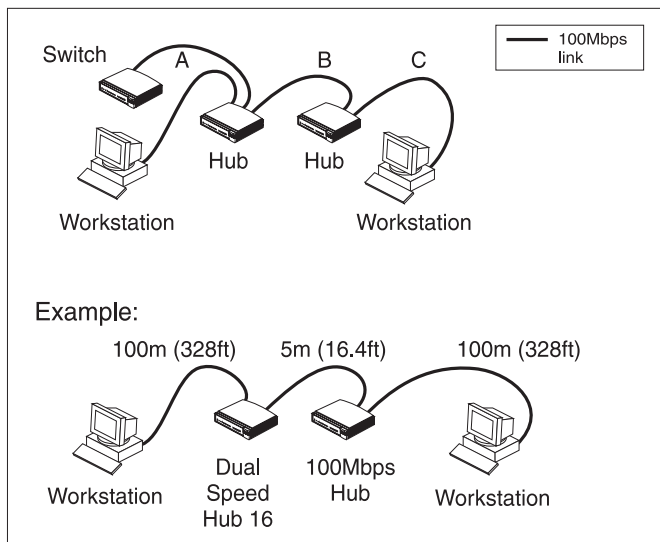

Configuration Rules and Example of a Fast Ethernet (100Mbps) Network

### Ethernet (10Mbps) Configuration Rules

You can connect a maximum of four Ethernet (10Mbps) hubs in series between workstations, or between a workstation and a non-repeater piece of equipment (such as a switch). Each cable must not exceed 100m (328ft). An example is shown below.

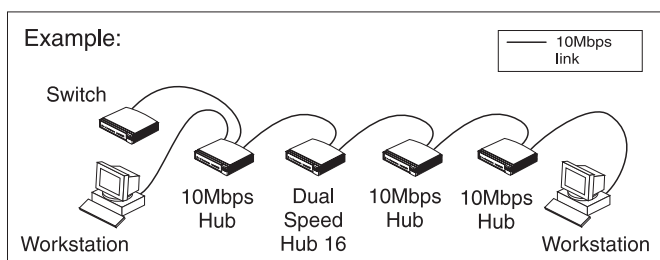

Example of Ethernet (10Mbps) Network

## Making the Connection to Another Hub

You can connect a 10BASE-T, 100BASE-TX, or another 10/100BASE-TX OfficeConnect hub to any port on the Dual Speed Hub 16. Use the following method:

- 1 Using a straight-through cable, connect the MDI/MDIX port of the Dual Speed Hub 16 to any of the ports on the other hub (as shown in the diagram below). If using an MDI/MDIX port on the other hub, set its MDI/MDIX switch to MDIX (out).
- 2 Set the MDI/MDIX switch for the MDI/MDIX port on the Dual Speed Hub 16 to MDI (in).

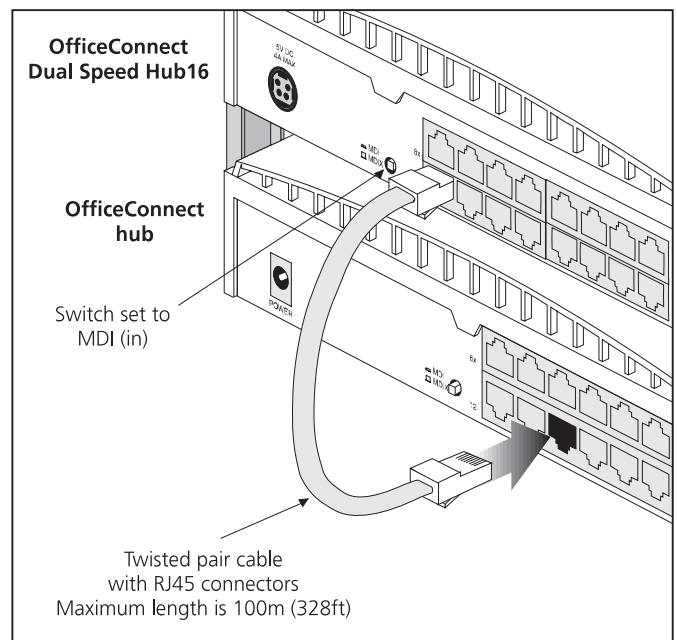

Correct Connections for OfficeConnect Hubs

## Powering Up and Checking Connections

When you have connected all the appropriate workstations and other equipment to the Hub, power on the Hub. For each port with a connection, the corresponding Port Status LED should be on. If the LED is off, check your connections.



**CAUTION:** Do not power the Hub off and on quickly. Wait about 5 seconds between power cycles.

## Spot Checks

At frequent intervals, visually check that:

- The Alert LED is off — this is the best way to find out if there are problems with your network
- Case vents are not obstructed
- Cabling is secure and not pulled taut

If you suspect a problem, refer to “Problem Solving” on page 7.



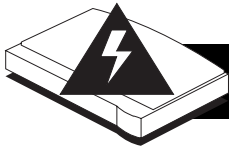

# IMPORTANT SAFETY INFORMATION



**WARNING:** Warnings contain directions that you must follow for your personal safety. Follow all directions carefully. You must read the following safety information carefully before you install or remove the unit:

- Exceptional care must be taken during installation and removal of the unit.
- Only stack the OfficeConnect unit with other OfficeConnect units.
- To ensure compliance with international safety standards, only use the power adapter that is supplied with the unit.
- The socket outlet must be near to the unit and easily accessible. You can only remove power from the unit by disconnecting the power cord from the outlet.
- This unit operates under SELV (Safety Extra Low Voltage) conditions according to IEC 950. The conditions are only maintained if the equipment to which it is connected also operates under SELV conditions.
- There are no user-replaceable fuses or user-serviceable parts inside the unit. If you have a physical problem with the unit that cannot be solved with problem solving actions in this guide, contact your supplier.
- Disconnect the power adapter before removing the unit.



**WARNING: RJ45 ports.** These are shielded RJ45 data sockets. They cannot be used as telephone sockets. Only connect RJ45 data connectors to these sockets.

**Power Cord Set:**

This must be approved for the country where it is used:

USA and Canada	The cord set must be UL-approved and CSA certified. The minimum specification for the flexible cord is: No. 18 AWG Type SV or SJ 3-conductor  The cord set must have a rated current capacity of at least 10A. The attachment plug must be an earth-grounding type with a NEMA 5-15P (15A, 125V) or NEMA 6-15P (15A, 250V) configuration.
Denmark	The supply plug must comply with section 107-2-D1, standard DK2-1a or DK2-5a.
Switzerland	The supply plug must comply with SEV/ASE 1011.

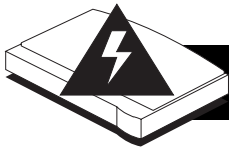

# WICHTIGE SICHERHEITSINFORMATIONEN



**WARNHINWEIS:** Warnhinweise enthalten Anweisungen, die Sie zu Ihrer eigenen Sicherheit befolgen müssen. Alle Anweisungen sind sorgfältig zu befolgen. Sie müssen die folgenden Sicherheitsinformationen sorgfältig durchlesen, bevor Sie das Gerät installieren oder ausbauen:

- Bei der Installation und beim Ausbau des Geräts ist mit höchster Vorsicht vorzugehen.
- Stapeln Sie das Gerät nur mit anderen OfficeConnect Gerätes zusammen.
- Aufgrund von internationalen Sicherheitsnormen darf das Gerät nur mit dem mitgelieferten Netzadapter verwendet werden.
- Die Netzsteckdose muß in der Nähe des Geräts und leicht zugänglich sein. Die Stromversorgung des Geräts kann nur durch Herausziehen des Gerätenetzkaabels aus der Netzsteckdose unterbrochen werden.

- Der Betrieb dieses Geräts erfolgt unter den SELV-Bedingungen (Sicherheitskleinstspannung) gemäß IEC 950. Diese Bedingungen sind nur gegeben, wenn auch die an das Gerät angeschlossenen Geräte unter SELV-Bedingungen betrieben werden.
- Es sind keine von dem Benutzer zu ersetzende oder zu wartende Teile in dem Gerät vorhanden. Wenn Sie ein Problem mit dem Gerät haben, das nicht mittels der Fehleranalyse in dieser Anleitung behoben werden kann, setzen Sie sich mit Ihrem Lieferanten in Verbindung.
- Vor dem Ausbau des Geräts das Netzadapterkabel herausziehen.



**WARNHINWEIS: RJ45-Anschlüsse.** Dies sind abgeschirmte RJ45-Datenbuchsen. Sie können nicht als Telefonanschlußbuchsen verwendet werden. An diesen Buchsen dürfen nur RJ45-Datenstecker angeschlossen werden.

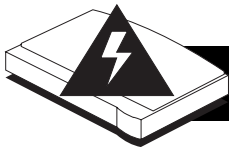

# CONSIGNES IMPORTANTES DE SÉCURITÉ



**AVERTISSEMENT:** Les avertissements présentent des consignes que vous devez respecter pour garantir votre sécurité personnelle. Vous devez respecter attentivement toutes les consignes. Nous vous demandons de lire attentivement les consignes suivantes de sécurité avant d'installer ou de retirer l'appareil:

- Faites très attention lors de l'installation et de la dépose du groupe.
- Seulement entasser l'appareil avec les autres appareils OfficeConnect.
- Pour garantir le respect des normes internationales de sécurité, utilisez uniquement l'adaptateur électrique remis avec cet appareil.
- La prise secteur doit se trouver à proximité de l'appareil et son accès doit être facile. Vous ne pouvez mettre l'appareil hors circuit qu'en débranchant son cordon électrique au niveau de cette prise.
- L'appareil fonctionne à une tension extrêmement basse de sécurité qui est conforme à la norme CEI 950. Ces conditions ne sont maintenues que si l'équipement auquel il est raccordé fonctionne dans les mêmes conditions.
- Il n'y a pas de parties remplaçables par les utilisateurs ou entretenues par les utilisateurs à l'intérieur de l'appareil. Si vous avez un problème physique avec l'appareil qui ne peut pas être résolu avec les actions de la résolution des problèmes dans ce guide, contactez votre fournisseur.
- Débranchez l'adaptateur électrique avant de retirer cet appareil.



**AVERTISSEMENT: Ports RJ45.** Il s'agit de prises femelles blindées de données RJ45. Vous ne pouvez pas les utiliser comme prise de téléphone. Branchez uniquement des connecteurs de données RJ45 sur ces prises femelles.

**Cordon électrique:**

Il doit être agréé dans le pays d'utilisation:

Etats-Unis et Canada	Le cordon doit avoir reçu l'homologation des UL et un certificat de la CSA.  Le cordon souple doit respecter, à titre minimum, les spécifications suivantes: calibre 18 AWG type SV ou SJ à 3 conducteurs  Le cordon doit être en mesure d'acheminer un courant nominal d'au moins 10 A.  La prise femelle de branchement doit être du type à mise à la terre (mise à la masse) et respecter la configuration NEMA 5-15P (15 A, 125 V) ou NEMA 6-15P (15 A, 250 V).
----------------------	--

3Com Corporation, 5400 Bayfront Plaza, Santa Clara, California, 95052-8145, U.S.A.

© 3Com Technologies, 1998. All rights reserved. No part of this documentation may be reproduced in any form or by any means or used to make any derivative work (such as translation, transformation, or adaptation) without permission from 3Com Technologies. 3Com Technologies reserves the right to revise this documentation and to make changes in content from time to time without obligation on the part of 3Com Technologies to provide notification of such revision or change. 3Com Technologies provides this documentation without warranty of any kind, either implied or expressed, including, but not limited to, the implied warranties of merchantability and fitness for a particular purpose. 3Com may make improvements or changes in the product(s) and/or the program(s) described in this documentation at any time.

**UNITED STATES GOVERNMENT LEGENDS:**

If you are a United States government agency, then this documentation and the software described herein are provided to you subject to the following restricted rights:

**For units of the Department of Defense: Restricted Rights Legend:** Use, duplication or disclosure by the Government is subject to restrictions as set forth in subparagraph (c) (1) (ii) for restricted Rights in Technical Data and Computer Software clause at 48 C.F.R. 52.227-7013. 3Com Centre, Boundary Way, Maylands Park South, Hemel Hempstead, Herts, HP2 7YU, U.K.

**For civilian agencies: Restricted Rights Legend:** Use, reproduction or disclosure is subject to restrictions set forth in subparagraph (a) through (d) of the Commercial Computer Software - Restricted Rights Clause at 48 C.F.R. 52.227-19 and the limitations set forth in 3Com Corporation's standard commercial agreement for the software. Unpublished rights reserved under the copyright laws of the United States.

If there is any software on removable media described in this documentation, it is furnished under a license agreement included with the product as a separate document, in the hard copy documentation, or on the removable media in a directory file named LICENSE.TXT. If you are unable to locate a copy, please contact 3Com and a copy will be provided to you.

Unless otherwise indicated, 3Com registered trademarks are registered in the United States and may or may not be registered in other countries.

3Com and OfficeConnect are registered trademarks of 3Com Corporation. Other brand and product names may be registered trademarks or trademarks of their respective holders.





# PROBLEM SOLVING

The Hub has been designed to aid you when detecting and solving possible problems with your network. These problems are rarely serious; the cause is usually a disconnected or damaged cable, or incorrect configuration. If this section does not solve your problem, contact your supplier for information on what to do next.

Perform these actions first:

- Ensure all network equipment is powered on.
- Power each piece of network equipment off, wait about 5 seconds and then power each one on.

Check the following symptoms and solutions:

**Power LED not lit.** Check your power adapter connection. If there is still no power, you may have a faulty power adapter which needs replacing with an identical OfficeConnect power adapter. **Do not use any other power adapter with the Hub.**

**Port Status LED not lit for a port that has a connection.** Check that you are using a 'straight-through' cable which is properly connected at both ends, and is not damaged. Refer to "Twisted Pair (TP) Cables" on page 3. Also check that the equipment connected to the Hub is powered on, operating correctly and contains the correct type of connection.

**Port Status LED lit yellow for a port with a 100Mbps device connected.** This may be because the cable is not of a high enough quality to carry Fast Ethernet signals (we recommend you use a Category 5 cable), or due to a problem with the network card (NIC) of the attached equipment.

**Port Status LED flashing.** The port is partitioned, probably due to a network loop. Examine your connections and remove the loop. Each piece of equipment needs only one connection to your Hub.

**Link between the Hub and another OfficeConnect hub not working.** Check your connections; follow the information given in the "Connecting Another OfficeConnect Hub" section on page 5. It is likely that an MDI/MDIX switch is incorrectly set.

**Alert LED continuously lit.** There is a problem with the network. Check the Port Status LEDs to try to identify the port that is causing the problem. If one of the Port Status LEDs is flashing, that port has partitioned, probably due to a network loop. Examine your connections and remove the loop. Each piece of equipment needs only one connection to your Hub.

If you cannot identify such a port, remove the port connections one at a time, waiting a few seconds between each port. If the Alert LED goes off, there is either a network loop (see above), or an excessive amount of traffic on that port connection. Check the Network Utilization LEDs to see if the network is heavily loaded (over 80%). Some pieces of network equipment operate by sending out frames regularly. Refer to the documentation that accompanies the piece of network equipment.

If the Alert LED is still lit after removing all of your connections, there may be a problem with your Hub. Power it off, wait about 5 seconds and then power it on. If the Alert LED comes back on continuously, contact your supplier.

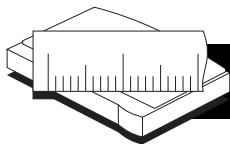

# DIMENSIONS AND STANDARDS

## Dimensions and Operating Conditions

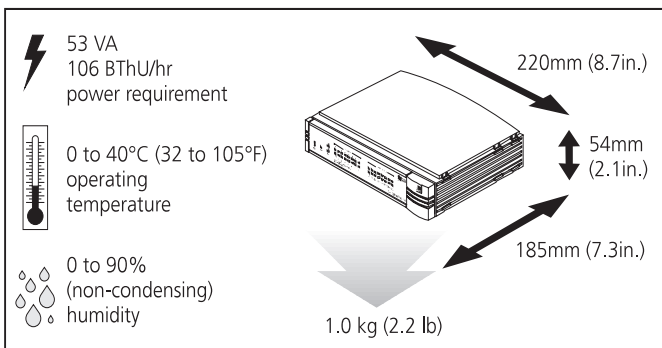

OfficeConnect Dual Speed Hub 16

## Standards

Functional:	ISO 8802/3 IEEE 802.3, 802.3u
Safety:	UL 1950, EN 60950 CSA 22.2 #950, IEC 950
Emissions:	EN 55022 Class B* FCC Part 15 Class B* ICES-003 Class B* VCCI Class B* AS/NZS 3548 Class B* EN50082-1 CNS 13438 Class A

\* Screened (shielded) cables must be used to ensure compliance with these EMC standards. Refer to "EMC Statements" on page 8 for conditions of operation.

Environmental:	EN 60068 (IEC 68)
Acoustic Noise:	ISO 7779 ISO 9295

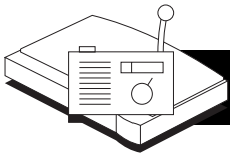

# EMC STATEMENTS

**FCC STATEMENT:** This equipment has been tested and found to comply with the limits for a Class B digital device, pursuant to part 15 of the FCC rules. These limits are designed to provide reasonable protection against harmful interference in a residential installation. This equipment generates, uses and can radiate radio frequency energy and, if not installed and used in accordance with the instructions, may cause harmful interference to radio communications. However, there is no guarantee that interference will not occur in a particular installation. If this equipment does cause harmful interference to radio or television reception, which can be determined by turning the equipment off and on, the user is encouraged to try to correct the interference by one or more of the following measures:

- Reorient or relocate the receiving antenna.
- Increase the separation between the equipment and the receiver.
- Connect the equipment into an outlet on a circuit different from that to which the receiver is connected.
- Consult the dealer or an experienced radio/TV technician for help.

**CSA STATEMENT:** This Class B digital apparatus meets all requirements of the Canadian Interference-Causing Equipment Regulations.

Cet appareil numérique de la classe B respecte toutes les exigences du Règlement sur le matériel brouilleur du Canada.

この装置は、情報処理装置等電波障害自主規制協議会（VCCI）の基準に基づくクラスB情報技術装置です。この装置は、家庭環境で使用することを目的としていますが、この装置がラジオやテレビジョン受信機に近接して使用されると、受信障害を引き起こすことがあります。  
取扱説明書に従って正しい取り扱いをして下さい。

警告使用者：這是甲類的資訊產品，在居住的環境中使用時，可能會造成射頻干擾，在這種情況下，使用者會被要求採取某些適當的對策。

The user may find the following booklet prepared by the Federal Communications Commission helpful:

*'How to Identify and Resolve Radio-TV Interference Problems'*

This booklet is available from the U.S. Government Printing Office, Washington, DC 20402, Stock No. 004-000-00345-4.

In order to meet FCC emissions limits, this equipment must be used only with cables which comply with IEEE 802.3.

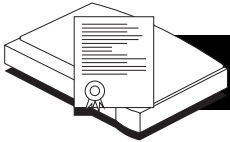

# LIFETIME LIMITED WARRANTY

The duration of the warranty for the OfficeConnect Dual Speed Hub 16 (3C16751) is lifetime, including the power supply, but excluding the fan, which has one (1) year warranty.

Advance hardware exchange is available during the first year from your date of purchase in accordance with 3Com's standard terms and conditions for such service. After the first year, the warranty reverts to 3Com's standard lifetime limited warranty.

To qualify for the lifetime limited warranty and the advance hardware exchange, you must submit the appropriate product warranty registration card to 3Com, otherwise this product will be warranted for a period of one (1) year without advance hardware exchange.

**HARDWARE:** 3Com warrants its hardware products to be free from defects in workmanship and materials, under normal use and service, for the following lengths of time from the date of purchase from 3Com or its Authorized Reseller:

- Network adapters**Lifetime
- Other hardware products**One year (unless otherwise specified above)
- Spare parts and spare kits**90 days

If a product does not operate as warranted above during the applicable warranty period, 3Com shall, at its option and expense, repair the defective product or part, deliver to Customer an equivalent product or part to replace the defective item, or refund to Customer the purchase price paid for the defective product. All products that are replaced will become the property of 3Com. Replacement products may be new or reconditioned. Any replaced or repaired product or part has a ninety (90) day warranty or the remainder of the initial warranty period, whichever is longer.

3Com shall not be responsible for any software, firmware, information, or memory data of Customer contained in, stored on, or integrated with any products returned to 3Com for repair, whether under warranty or not.

**SOFTWARE:** 3Com warrants that the software programs licensed from it will perform in substantial conformance to the program specifications therefor for a period of ninety (90) days from the date of purchase from 3Com or its Authorized Reseller. 3Com warrants the media containing software against failure during the warranty period. No updates are provided. 3Com's sole obligation with respect to this express warranty shall be (at 3Com's discretion) to refund the purchase price paid by Customer for any defective software products, or to replace any defective media with software which substantially conforms to 3Com's applicable published specifications. Customer assumes responsibility for the selection of the appropriate applications program and associated reference materials. 3Com makes no warranty or representation that its software products will work in combination with any hardware or applications software products provided by third parties, that the operation of the software products will be uninterrupted or error free, or that all defects in the software products will be corrected. For any third party products listed in the 3Com software product documentation or specifications as being compatible, 3Com will make reasonable efforts to provide compatibility, except where the non-compatibility is caused by a "bug" or defect in the third party's product.

**STANDARD WARRANTY SERVICE:** Standard warranty service for hardware products may be obtained by delivering the defective product, accompanied by a copy of the dated proof of purchase, to 3Com's Corporate Service Center or to an Authorized 3Com Service Center

during the applicable warranty period. Standard warranty service for software products may be obtained by telephoning 3Com's Corporate Service Center or an Authorized 3Com Service Center, within the warranty period. Products returned to 3Com's Corporate Service Center must be pre-authorized by 3Com with a Return Material Authorization (RMA) number marked on the outside of the package, and sent prepaid, insured, and packaged appropriately for safe shipment. The repaired or replaced item will be shipped to Customer, at 3Com's expense, not later than thirty (30) days after receipt of the defective product by 3Com.

**WARRANTIES EXCLUSIVE:** IF A 3COM PRODUCT DOES NOT OPERATE AS WARRANTED ABOVE, CUSTOMER'S SOLE REMEDY FOR BREACH OF THAT WARRANTY SHALL BE REPAIR, REPLACEMENT, OR REFUND OF THE PURCHASE PRICE PAID, AT 3COM'S OPTION. TO THE FULL EXTENT ALLOWED BY LAW, THE FOREGOING WARRANTIES AND REMEDIES ARE EXCLUSIVE AND ARE IN LIEU OF ALL OTHER WARRANTIES, TERMS, OR CONDITIONS, EXPRESS OR IMPLIED, EITHER IN FACT OR BY OPERATION OF LAW, STATUTORY OR OTHERWISE, INCLUDING WARRANTIES, TERMS, OR CONDITIONS OF MERCHANTABILITY, FITNESS FOR A PARTICULAR PURPOSE, AND SATISFACTORY QUALITY. 3COM NEITHER ASSUMES NOR AUTHORIZES ANY OTHER PERSON TO ASSUME FOR IT ANY OTHER LIABILITY IN CONNECTION WITH THE SALE, INSTALLATION, MAINTENANCE OR USE OF ITS PRODUCTS.

3COM SHALL NOT BE LIABLE UNDER THIS WARRANTY IF ITS TESTING AND EXAMINATION DISCLOSE THAT THE ALLEGED DEFECT IN THE PRODUCT DOES NOT EXIST OR WAS CAUSED BY CUSTOMER'S OR ANY THIRD PERSON'S MISUSE, NEGLIGENCE, IMPROPER INSTALLATION OR TESTING, UNAUTHORIZED ATTEMPTS TO REPAIR OR MODIFY, OR ANY OTHER CAUSE BEYOND THE RANGE OF THE INTENDED USE, OR BY ACCIDENT, FIRE, LIGHTNING, OR OTHER HAZARD.

**LIMITATION OF LIABILITY.** TO THE FULL EXTENT ALLOWED BY LAW 3COM ALSO EXCLUDES FOR ITSELF AND ITS SUPPLIERS ANY LIABILITY, WHETHER BASED IN CONTRACT OR TORT (INCLUDING NEGLIGENCE), FOR INCIDENTAL, CONSEQUENTIAL, INDIRECT, SPECIAL, OR PUNITIVE DAMAGES OF ANY KIND, OR FOR LOSS OF REVENUE OR PROFITS, LOSS OF BUSINESS, LOSS OF INFORMATION OR DATA, OR OTHER FINANCIAL LOSS ARISING OUT OF OR IN CONNECTION WITH THE SALE, INSTALLATION, MAINTENANCE, USE, PERFORMANCE, FAILURE, OR INTERRUPTION OF ITS PRODUCTS, EVEN IF 3COM OR ITS AUTHORIZED RESELLER HAS BEEN ADVISED OF THE POSSIBILITY OF SUCH DAMAGES, AND LIMITS ITS LIABILITY TO REPAIR, REPLACEMENT, OR REFUND OF THE PURCHASE PRICE PAID, AT 3COM'S OPTION. THIS DISCLAIMER OF LIABILITY FOR DAMAGES WILL NOT BE AFFECTED IF ANY REMEDY PROVIDED HEREIN SHALL FAIL OF ITS ESSENTIAL PURPOSE.

Some countries, states, or provinces do not allow the exclusion or limitation of implied warranties or the limitation of incidental or consequential damages for certain products supplied to consumers or the limitation of liability for personal injury, so the above limitations and exclusions may be limited in their application to you. This warranty gives you specific legal rights which may vary depending on local law.

**GOVERNING LAW:** This Limited Warranty shall be governed by the laws of the state of California.

**3Com Corporation,** 5400 Bayfront Plaza, Santa Clara, CA, 95052-8145, U.S.A.  
Tel: (408) 326-5000

9/1/96

**Year 2000 Compliance:** For information on Year 2000 compliance and 3Com products, visit the 3Com Year 2000 Web page:  
<http://www.3com.com/products/yr2000.html>

**Environmental Statement:** Please recycle this user guide after use.

Please e-mail any comments about this document to 3Com at: [pddtechpubs\\_comments@3Com.com](mailto:pddtechpubs_comments@3Com.com). Please include the document title (OfficeConnect Dual Speed Hub 16 User Guide), part number (DUA1675-1AAA01) and, if appropriate, the page number.