



CANdrive™ Module

Installation and Operations Manual

In order to consistently bring you the highest quality, full featured products, we reserve the right to change our specifications and designs at any time. The latest version of this manual can be found at www.fwmurphy.com.

Warranty - A two year warranty on materials and workmanship is given with this FW Murphy product. A copy of the warranty may be viewed or printed by going to www.fwmurphy.com/support/warranty.htm. In the event of a fault or technical query, please contact your Murphy representative for technical support.



Please read the following information before installing.

BEFORE BEGINNING INSTALLATION OF THIS MURPHY PRODUCT:

- A visual inspection of this product for damage during shipping is recommended before installation.
- It is your responsibility to ensure that qualified mechanical and electrical technicians install this product.
- Disconnect all electrical power to the machine.
- Make sure machine cannot operate during installation.
- Follow all safety warnings of the machine manufacturer.
- Read and follow all installation instructions.
- Please contact FW MURPHY immediately if you have any questions.

Table of Contents

General Information	1
Introduction	1
Installation Instructions	2
Configuration.....	2
Electrical Connection	3
Panel Mounting	5
Operation and Maintenance	6
Gage Driver Outputs	6
Indicating LEDs	6
Maintenance.....	7
Specifications	8
Power Supply	8
Inputs	8
Outputs.....	8
General	8

(THIS PAGE INTENTIONALLY LEFT BLANK)

General Information

Introduction

As part of the MurphyLink® family, the **Murphy CANdrive™** offers a cost effective instrument solution for modern electronic engines. CANdrive acts as an interface between ECU CANbus/J1939 transmitted data and standard electric indicating gages. CANdrive and electric gages are an alternative solution to retrofitting of engine senders, magnetic pickups and associated wiring.

CANdrive has dedicated outputs for a tachometer, oil pressure, and coolant temperature electric gages. User configurable links allow for selectivity between 12 or 24 VDC systems, and for all gage outputs to be selected for Murphy, VDO, or Datcon.

CANdrive is packaged in a compact, surface mounted case with epoxy encapsulation for maximum durability and environmental sealing. Electrical connection is via a 12-way automotive-type connector.

Standard Model Options

Stock Code	Model / Description
78-70-0363	CDV100F , CAN drive J1939 to electric gage interface. 1 x CAN status LED, connector forward
78-70-0364	CDV300R , CANdrive J1939 to electric gage interface. 8 x status/fault LEDs, connector rearward. Model CDVG sealing gasket included.
78-00-0437	CDV-PW-30 , CANdrive power and CAN harness. Length: 30 in. (0.762m). Included with CDV100F and CDV300R

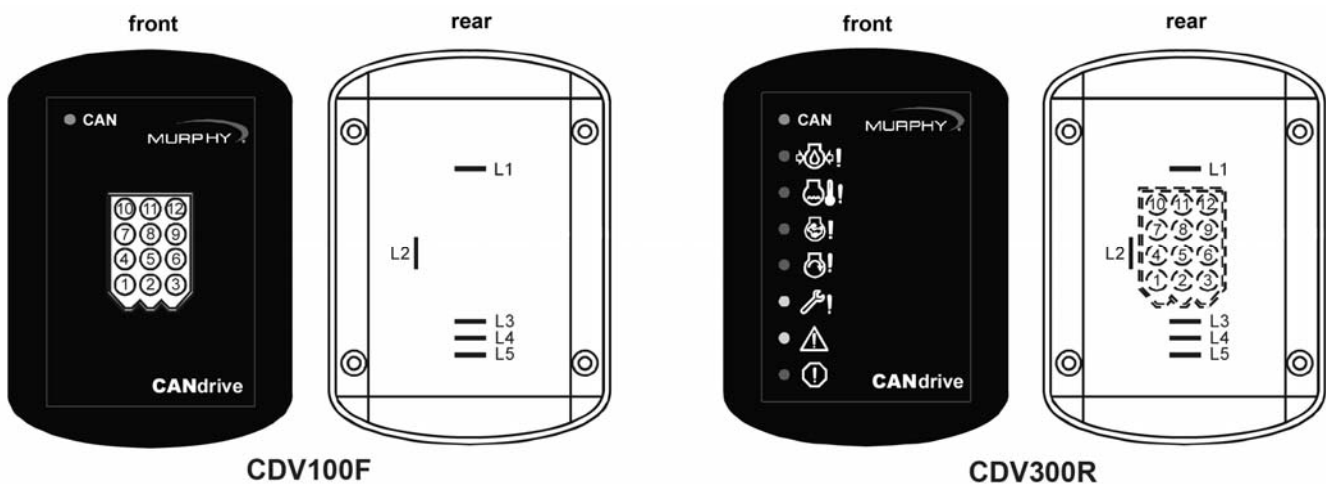

Installation Instructions

Configuration

CANdrive modules are supplied with 5 circuit board links soldered in place. These wire links, labeled L1 through L5, are located on the back side of the unit.

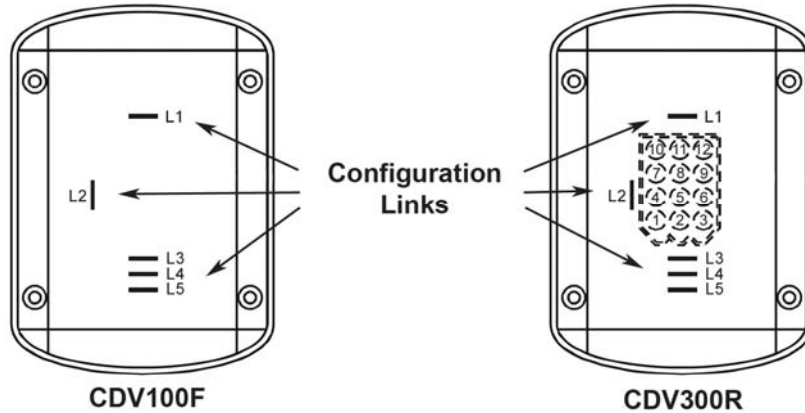

The links allow configuration of operating options by snipping the appropriate wire according to the following configuration table.



WARNING: The configuration links are one-time breakable and are not replaceable. Care must therefore be taken to select the correct options before cutting links.

Configuration Table

Link	Function	Link Options
L1	CANbus 120 Ohm resistor	Cut L1 to remove 120 Ohm terminating resistor.
L2	DC supply voltage	Leave L2 intact for 12V operation Cut L2 for 24V operation
L3 L4	Gage output options	Leave L3 and L4 intact for Murphy gages (see compatibility table) Cut L3 only for Datcon gages (see compatibility table) Cut L4 only for VDO gages (see compatibility table)
L5	VDO pressure gage range	Leave L5 intact for 0-7 bar gages Cut L5 for 0-10 bar gages

Gage Compatibility Tables

Pressure gauge compatibility table: pressure versus gauge equivalent sender resistance (Ohms)

Pressure	psi	0	10	20	30	40	50	60	70	80	90	100	110	120	130	140	150
	bar	0	0.7	1.4	2.1	2.8	3.4	4.1	4.8	5.5	6.2	6.9	7.6	8.3	9.0	9.7	10.3
Murphy		240	205	171	143	123	103	88	74	60	47	33					
Datcon		240	200	165	135	115	95	78	63	48	35	25					
VDO 0 – 7 bar		0	17	37	53	69	83	95	107	118	130	140					
VDO 0 –10 bar		10															184

Temperature gauge compatibility table: temperature versus gauge equivalent sender resistance (Ohms)

Temperature	°C	40	50	60	70	80	90	100	110	120	130	140
	°F	104	122	140	158	176	194	212	230	248	266	284
Murphy		1029	680	460	321	227	164	120	89	74	52	40
Datcon		900	600	400	278	200	141	104	74	50	27	4
VDO		282.4	190.0	134.0	95.2	69.1	51.2	38.5	29.4	22.7	18.0	14.5

Electrical Connection

CANdrive modules electrical connection is through a 12-way automotive type receptacle shown right. CANdrive models are available with the connector facing forward through the front label ('F' option, e.g. model CDV100F), or rearward through the epoxy encapsulation ('R' option, model CDV300R).

CANdrive electrical connection is through a 12-way automotive type receptacle. A 30-inch connector harness is included with each CANdrive model, and has each wire individually labeled for ease of installation.

Typical Connection

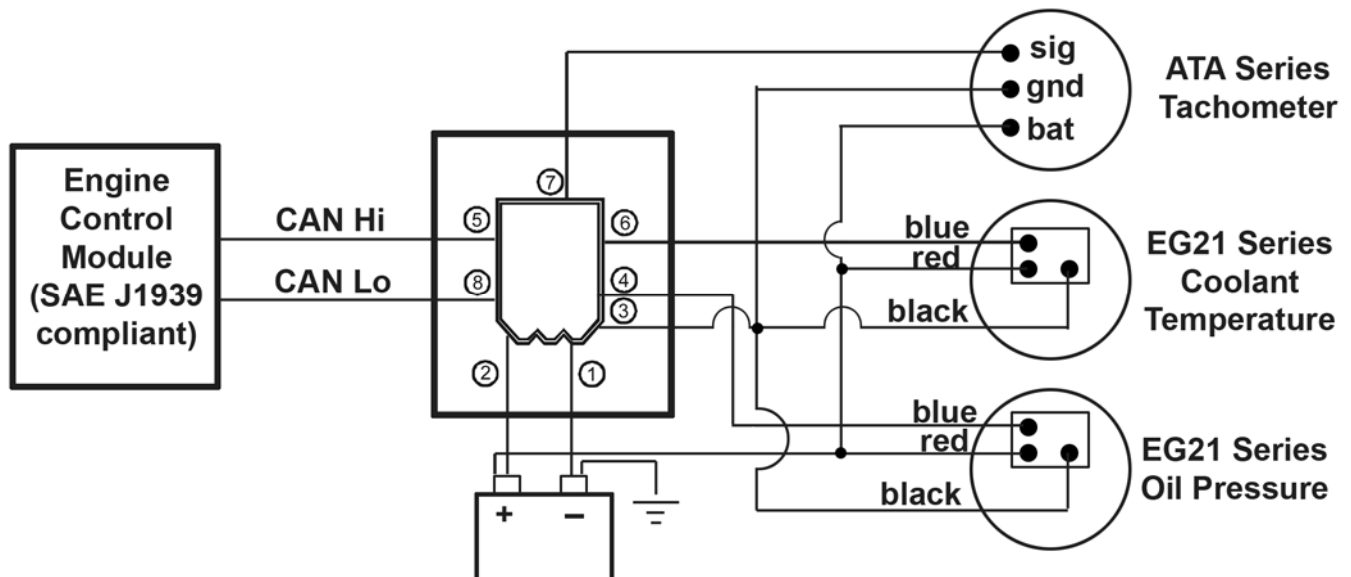

Terminal Functions

PIN	Function
1	Negative DC, power supply
2	Positive DC, power supply
3	Negative DC, gage common return CANdrive modules are supplied for use with 12V (7 to 16V) DC operation. If 24V (19 to 30V) DC operation is required, remove (cut) rear link L2. Connect a 1 Amp anti-surge fuse in the positive DC line (pin 2).
4	Oil pressure gage output
6	Coolant temperature gage output Pins 4 and 6 give a variable current output for driving oil pressure and coolant temperature electric gages. The current versus pressure/temperature curve is specific to each gage type, and must be selected by cutting appropriate links L3, L4 and L5 - see Configuration section above.
7	Tachometer output Pin 7 gives a square wave output (0V to battery positive DC), with a frequency that is proportional to engine speed. At 1500 RPM engine speed, the output is approximately 121 Hz, suitable for driving charge alternator based tachometers such as the Murphy AT(H)A series. Pin 7 gives no output below 100 RPM engine speed. Connect each output to the appropriate gage/ tachometer signal input. Gage/tachometer negative terminals should be common to battery negative, ideally via dedicated wiring to terminal 3. (The use of dedicated return wiring to pin 3 rather than a ground return will minimize gage inaccuracies caused by ground noise.)
5	CAN Hi
8	CAN Lo Connect these terminals to the engine CANbus, taking care to observe the correct polarity. The CANbus cable screen/shield is typically connected to ground at the ECU end: refer to the engine manufacturer's installation guidelines. CANdrive modules are supplied with a 120 Ohm network terminating resistor fitted in-circuit between CAN Hi and CAN Lo. If CANdrive module is not positioned at the end of the CANbus network, remove the resistor by snipping out rear link L1.
9	Reserved for future use
10	Factory use
11	Factory use
12	Factory use

NOTE: Connection Pins 9, 10, 11, and 12 are reserved for future use, or are used in the factory setup of CANdrive modules. Do not connect wiring or equipment to these terminals. Connection can result in permanent damage to CANdrive modules.

Panel Mounting



WARNING: Do not install the CANdrive module near exhaust manifolds, turbochargers or other engine locations that might exceed the maximum allowable operating temperature of 185°F (85°C).

CANdrive modules are surface-mounted with four no.4 screws, fixing center dimensions as shown. Select screw length according to panel thickness, ensuring a maximum of 1/2 inch (13mm) screw depth into the CANdrive module fixing holes.

Model CDV100F, with forward facing connector, is designed for surface-mounting inside an enclosed panel.

Model CDV300F, with additional LEDs and rearward facing connector, is designed for front-of-panel mounting: these modules require an additional 2.4" x 1.6" (60 x 40mm) cut-out for rear access to connector and links. The CDV300F includes a CDVG gasket (fitted into a well behind the rim of the case) to provide front environmental sealing to IP65.

Rear view dimensions

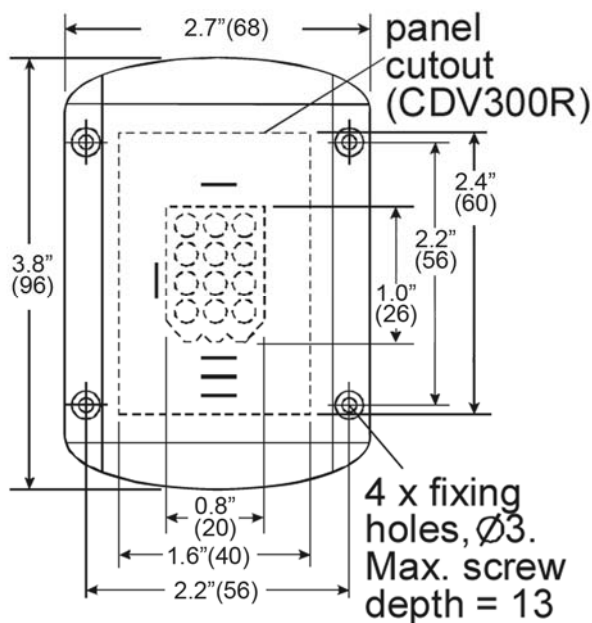

inches(mm)

Before mounting, ensure that the final position allows access for:

- Connection of the included wire harness.
- Configuration of links L1 to L5 (position as shown). Alternatively, ensure that the links are set correctly before mounting. See Configuration section below for full details.

Operation and Maintenance

Gage Driver Outputs







Gage outputs operate when CANdrive module reads valid J1939 data for engine speed, oil pressure and coolant temperature. If CANdrive module stops receiving valid data, the gage outputs are maintained at the last known value for approximately five seconds, after which time the outputs are turned off.

Indicating LEDs

All standard models have a green CAN status LED. A flashing CAN status LED indicates that CANdrive module is powered, but is not receiving any J1939 data. A constantly lit CAN status LED indicates a good CANbus connection and J1939 activity. (Note: J1939 activity can originate from ANY device on the CANbus network, and may not be valid data from the engine ECU.)

Model CDV300R has additional LEDs for indication of engine faults, as transmitted from the ECU. CANdrive modules respond to single DM1 (active fault code) messages that contain a Suspect Parameter Number (SPN), Fault Mode Indicator (FMI) and warning/stop lamp data. CANdrive modules also read multi-packet transport messages broadcast using the broadcast address message (BAM) protocol.

LEDs typically light continuously to indicate a shutdown fault, and flash to indicate a (non-shutdown) warning fault.

LED	Mode	Fault	J1939	
			SPN	FMI
	On	Low oil pressure shutdown	100	1
	Flashing	Low oil pressure warning	100	> 1
	On	Coolant temperature shutdown	110	0
	Flashing	Coolant temperature warning	110	> 0
	On	Overspeed shutdown	190	0
	Flashing	Overspeed warning	190	> 0
	-	Reserved for future use	-	-
	-	Reserved for future use	-	-
	Flashing	Warning fault	-	-
	Flashing	Shutdown fault	-	-

CANdrive modules can handle up to 8 simultaneous faults at one time; additional fault messages are not registered. When a fault becomes inactive and is no longer broadcast, the appropriate LED goes out after approximately two seconds.

Maintenance

CANdrive modules have no user-serviceable parts. Maintenance is therefore limited to the following preventative checks:

- Check that electrical connections are secure.
- Check that the CANdrive module is securely mounted and kept free from exposure to water or build up of excessive dust/dirt. The front label and casing may be wiped with a clean, damp cloth. Do not use cleaning solvents.

Specifications

Power Supply

- Operating voltage:
 - 12V range (link L2-in place) 7-16 VDC
 - 24V range (link L2-cut) 19-30 VDC
- Current consumption:
 - CDV100F: 25mA typical
 - CDV300R: 50mA, typical (2 LEDs lit)

Inputs

- CANbus:
 - SAE J1939 protocol, Input fitted with 120 Ohm terminating resistor, removable by cutting link L1.

Outputs

- Oil pressure gage, coolant temperature gage
 - Link selectable for Murphy, VDO or Datcon electric gages
- Tachometer
 - Pulsed DC, approximately 121 Hz @ 1500 RPM

General

- Overall dimensions (W x H x D)
 - Case: 2.7x3.8x0.9 inch (68x96x22mm) (allow 2 inches (50mm) depth with connector)
- Weight: approximately .18 lbs (80g)
- Environmental sealing
 - IP60
 - CDV300R: IP65 from front with CDVG gasket (included)
- Operating ambient temperature: -40° F to 185° F (-40°C to +85°C)
- Storage temperature: -67°F to 221°F (-55°C to 105°C)
- Operating Vibration: .02 lbs (10g) (5-2000 Hz)
- Operating Shock: .11 lbs (50g) (3-axis)

MURPHY, the Murphy logo, and CANdrive are registered and/or common law trademarks of Murphy Industries, Inc. This document, including textual matter and illustrations, is copyright protected by Murphy Industries, Inc., with all rights reserved. (c) 2007 Murphy Industries, Inc. Other third party product or trade names referenced herein are the property of their respective owners and are used for identification purposes only.

FW MURPHY

P.O. Box 470248
Tulsa, Oklahoma 74147 USA
+1 918 317 4100 Fax: +1 918 317 4266
E-mail: sales@fwmurphy.com

INDUSTRIAL PANEL DIVISION

Fax: +1 918 317 4124
E-mail: ipdsales@fwmurphy.com

MURPHY POWER IGNITION

Web site: www.murphy-pi.com

www.fwmurphy.com

CONTROL SYSTEMS & SERVICES DIVISION

P.O. Box 1819
Rosenberg, Texas 77471 USA
Phone: +1 281 633 4500 Fax: +1 281 633 4588
E-mail: sales@fwmurphy.com

FRANK W. MURPHY, LTD

Church Rd Laverstock
Salisbury SP1 1QZ UK
Phone: +44 172 241 0055 Fax: +44 172 241 0088
E-mail: sales@fwmurphy.co.uk
Web site: www.fwmurphy.co.uk

COMPUTRONIC CONTROLS, LTD

41 - 43 Railway Terrace Nechells
Birmingham B7 5NG UK
Phone: +44 121 327 8500 Fax: +44 121 327 8501
E-mail: info@computroniccontrols.com
Web site: www.computroniccontrols.com

FW MURPHY INSTRUMENTS (HANGZHOU) CO. LTD

77 23rd Street
Hangzhou Economic & Technological Development Area
Hangzhou, Zhejiang 310018 China
Phone: +86 571 8788 6060 Fax: +86 571 8684 8878



Printed in U.S.A.