



4830 TRANSPORT DRIVE, DALLAS, TX 75247
PHONE: 214-638-6010 FAX: 214-905-0806 www.sterlinghvac.com

INSTALLATION, OPERATION AND MAINTENANCE MANUAL FOR SDR MODEL DIRECT GAS-FIRED HEATERS

ATTENTION: READ THIS MANUAL AND ALL LABELS ATTACHED TO THE UNIT CAREFULLY BEFORE ATTEMPTING TO INSTALL, OPERATE OR SERVICE THIS UNIT! CHECK UNIT RATING PLATE FOR TYPE OF GAS AND ELECTRICAL SPECIFICATIONS AND MAKE CERTAIN THAT THESE AGREE WITH THOSE AT POINT OF INSTALLATION. RETAIN FOR FUTURE REFERENCE.

FOR YOUR SAFETY

The use and storage of gasoline or other flammable vapors and liquids in open containers in the vicinity of this appliance is hazardous.



FOR YOUR SAFETY

- If you smell gas:
1. Open Windows
 2. Don't touch electrical switches.
 3. Extinguish any open flame.
 4. Immediately call your gas supplier.



WARNING: Improper installation, adjustment, alteration, service or maintenance can cause property damage, injury or death. Read the installation, operating and maintenance instructions thoroughly before installing or servicing this equipment.

WARNING: Install, operate and maintain unit in accordance with manufacturer's instructions to avoid exposure to fuel substances or substances for incomplete combustion which can cause death or serious illness. The state of California has determined that these substances may cause cancer, birth defects, or other reproductive harm.

INSTALLER'S RESPONSIBILITY

Installer Please Note: This equipment has been test fired and inspected. It has been shipped free from defects from our factory. However, during shipment and installation, problems such as loose wires, leaks or loose fasteners may occur. **It is the installer's responsibility to inspect and correct any problems that may be found.**

POST AND MAINTAIN THESE INSTRUCTIONS IN LEGIBLE CONDITION



SECTION I - FORWARD

As is the case with any fine piece of equipment, care must be taken to provide the proper attention to the operation and maintenance details of this machine.

This manual of instructions has been prepared in order for you to become well-acquainted with those details, and in doing so, you will be able to give your Direct Gas-Fired System the care and attention which any piece of equipment needs and deserves.

Table Of Contents

Section I: Forward and Table of Contents.....	2
Section II: General Information.....	2
Section III: Installation.....	3
Section IV: Pre Start-Up.....	5
Section V: Unit Start-Up.....	5
Section VI: Unit Shut Down.....	6
Section VII: Troubleshooting Guide.....	7
Section VIII: Maintenance Schedule and Lubrication Requirements.....	13
Section IX: Maxon NP-I Airflo® Burners.....	16
Section X: Maxitrol Valve Adjustments and Preliminary Circuit Analysis.....	17
Section XI: Replacement Parts.....	19
Section XII: Recirculation.....	20

SECTION II - GENERAL INFORMATION

A. Purpose

The purpose of this manual is to present a guide for proper installation, maintenance, and operation of the Direct Gas-Fired System, and supplement, but not to replace, the services of qualified field service personnel to supervise the initial start-up and adjustment of the unit. Persons without previous experience with commercial and industrial heating equipment should not attempt the initial adjustment and checkout procedure which is essential before such installations may be considered ready for operation. This manual should be made readily available to all operating personnel as an aid in troubleshooting and proper maintenance.

B. Shipping

Direct Gas-Fired units are shipped completely assembled where shipping limitations allow. Optional inlet hoods or other large accessories are assembled and shipped mounted and wired whenever possible within limitations of shipping and handling. Any optional accessories shipped separately are shipped as assembled sections.

Shipments are made F.O.B. Dallas, Texas by flatbed truck or LTL shipment. The unit is securely strapped, tied, and blocked to prevent shipping damage. All shipments are checked by an inspector before they are accepted by the carrier. Parts that are shipped unmounted are noted on the bill of lading. These parts, where feasible, are packaged and shipped with the units. Upon receipt of shipment, all units should be checked against the bill of lading to insure all items have been received. All equipment (and any optional accessories) should be checked carefully for physical damage in the presence of the carrier's representative. If parts are missing or damage has occurred, a claim should be filed immediately with the carrier.

All Direct Gas-Fired units are given a minimum 140 point operations test and control circuit checkout before shipment. Copies of the wiring diagram, piping diagram and bill of material are included with each unit shipped. If correspondence with the factory is necessary, please provide the unit model and serial number.

C. Optional Factory Service

Periodic service on any piece of mechanical equipment is necessary for efficient operation. A nationwide service support network is available to provide quick and dependable servicing of make-up air, heating, ventilating, or air handling types of equipment. The factory also offers start-up service which includes the presence of a service engineer to supervise the initial start-up and adjustment of the equipment and provide instructions for the owner's maintenance personnel on proper operations and maintenance. Consult factory for quotations on periodic or start-up service.

SECTION III - INSTALLATION

This equipment must be installed and wired in accordance with regulations of the National Board of Fire Underwriters, National Electrical Code, and local governing bodies. The following recommendations are not intended to supplant any requirements of federal, state, or local codes having jurisdiction. Authorities having jurisdiction should be consulted before installations are made. Local codes may require additional safety controls and/or interlocks.

All installations in airplane hangers must be in accordance with current ANSI/NFPA No. 409. All installations in public garages must be in accordance with the current Standard for Parking Garages, NFPA No. 88A, or the Standard for Repair Garages, NFPA No. 88B, and with CAN/CGA B149 Installation Codes.

CAUTION: Do not install heating system in corrosive or flammable atmospheres! Premature failure of, or severe damage to the unit will result!

CAUTION: Heating system must not be installed in locations where air for combustion would contain chlorinated, halogenated or acidic vapors. If located in such an environment, premature failure of the unit will occur!

A. Handling the Equipment

The Direct Gas-Fired unit has been designed for rigging and handling through the use of special lifting lugs installed on the ends of each unit. As explained previously, the basic unit is designed for shipping in one piece where shipping limitations allow. Some optional accessories may require field mounting.

When unloading and setting the unit, use the lifting lugs provided or move the equipment on rollers. Hooks, jacks or chains must not be used around the casing, main control panel or exterior mounted controls.

During transit, unloading and setting of the unit, bolts and nuts may have become loosened, particularly in the pillow block ball bearing assemblies in the fan section. It is recommended that all nuts and set screws be tightened. Turn fan shaft by hand to make certain that blower does not rub against blower housing, and that bearing set screws are tight.

Open the cover on the electrical control box located on the unit. Inspect all wire terminals and wiring terminations to ensure that all connections are tight.

If this unit is not installed immediately, cover all openings that might be exposed to the weather. Rotate fan monthly.

B. Locating the Unit

Prior to locating the unit, authorities having jurisdiction should be consulted before installations are made. Approval permits should be checked against the unit received.

Recirculation of room air is not permitted. All air must be ducted from the outdoors.

If in doubt regarding the application of this appliance, consult the factory.

Locate the unit exactly level. Special attention should be given to the duct, electrical, and fuel connection points. Install duct work with adequate flexible connections to isolate vibrations from the duct work. All duct work should have taped or caulked seams. Duct work should be properly sized so as not to inhibit airflow. This information should be cross-checked with the position of support beams and stand pipes to insure that clearance dimensions coincide with those of the unit. The minimum clearance to combustible material must be maintained as listed in Table I.

Table I

Minimum clearance to combustible material and access clearance (consult local codes and regulations)

Clearances to Combustible Material		
	Vertical Units	Horizontal Units
Front*	36 inches	36 inches
Rear	6 inches	6 inches
Right	6 inches	6 inches
Left	6 inches	6 inches
Top	12 inches	12 inches
Floor	Zero	6 inches

* Consider control side as front of unit.

On outdoor curb mounted installations, flash and seal roof curb to prevent leakage. The cross section of factory provided curb is formed to accept wood nailing strip and insulation provided by others.

C. Location of Accessories

Where applicable, standard or optional accessories will be placed inside the fan section of the unit for shipment, and must be removed and installed by the mechanical or electrical contractor.

Field provided discharge or inlet dampers must be equipped with an end switch and interlocked to insure maximum design opening before starting and running circuits may be energized.

Field constructed intake accessories should be properly designed to minimize the entry of rain and snow.

Adequate building relief must be provided, so as to not over-pressurize the building, when the heater is operating at its rated capacity. This can be accomplished by taking into account, through standard engineering methods, the structure's designed infiltration rate, by providing properly sized relief openings, by interlocking a powered exhaust system, or by a combination of these methods.

D. Electrical Connections

WARNING: Open all disconnect switches and secure in that position before wiring unit. Failure to do so may result in personal injury or death from electrical shock.

WARNING: Controls must be protected from water. Do not allow water to drip on the ignition system.

NOTE: Before installing any wiring, check the unit rating plate for supply power rating.

All electrical connections and wiring must conform to the current edition of: ANSI/NFPA No. 70 National Electrical Code and applicable state and local codes.

Entry location for all field-installed and control wiring is located beside the control panel.

If optional disconnect is not furnished with heater, the field provided disconnect must be of the proper size and voltage. Refer to unit nameplate for minimum circuit ampacity and voltage. The disconnect must be installed in accordance with Article 430 of the current edition of ANSI/NFPA No. 70 National Electrical Code.

Check the supply voltage before energizing the unit. The maximum voltage variation unbalance must not exceed 2%.

NOTE: Should any original wire supplied with the heater have to be replaced, it must be replaced with wiring material having a temperature rating of at least 105° C.

E. Field Piping

All gas piping must be in accordance with the requirements outlined in the National Fuel Gas Code - ANSI Z223.1. It is required that a ground union be installed adjacent to the manifold for easy servicing. A drip leg and/or filter should be provided upstream of the unit's inlet gas connection. A shut-off must be located external of the unit's enclosure. The location of this valve must comply with all local codes. A 1/8 inch N.P.T. test gauge connection must be installed immediately upstream of the gas supply connection to the unit.

Refer to the heaters rating plate for determining the minimum gas supply pressure for obtaining the maximum gas capacity for which this heater is specified.

DANGER: Never use an open flame to detect gas leaks. Explosive conditions may exist which would result in personal injury or death.

WARNING: To avoid equipment damage or possible personal injury, do not connect gas piping to this unit until a supply line pressure/leak test has been completed. Connecting the unit before completing the pressure/leak test may damage the unit gas valve and result in a fire hazard.

The gas line should be supported so that no strain is placed on the unit. Pipe compounds, which are not soluble to liquid petroleum gases, should be used on threaded joints.

The appliance and its individual shutoff valve must be disconnected from the gas supply piping system during any pressure testing of that system at test pressures in excess of 1/2 PSIG.

The appliance must be isolated from the gas supply piping system by closing its individual manual shutoff valve during any pressure testing of the gas supply piping system at test pressure equal to or less than 1/2 PSIG.

Correctly sized piping must be run to the unit. Please note that gas line pressure must be as shown on rating plate when unit is operating at full input.

F. Field Wiring and Remote Control Installation

1. Connect the power lines to the line side of the main disconnect switch.
2. Mount and wire remote control panel, thermostats, temperature sensors, and any other field installed controls as indicated on the unit control wiring diagram.
3. Connect the wires to the appropriate field wiring terminals as indicated on the unit control wiring diagram.
4. If the optional low-temperature limit was not an integral part of the heater, the factory recommends that a low-temperature limit control be installed in areas where freeze protection is needed in the event of burner shut-down.

G. Locating Temperature Controls

The room or outdoor thermostats should be mounted where they will not be subjected to direct impact of the heated air or radiant heat from the sun. It is also recommended that thermostats, especially those with mercury bulb contacts, be mounted on a vibration free surface. Interior walls or the side of building columns away from the heater are usually the location best suited for mounting thermostats.

Controls with outdoor bulbs require that the outdoor bulb be shielded from direct radiation from the sun. Unit mounted sensors are factory located and mounted.

SECTION IV - PRE START-UP

A. Pre Start-Up

All equipment has been factory tested, adjusted, metered and inspected to meet conditions set at the time the order was placed. Only minimal adjustments should be required. All information in this service manual is typical. All products are semi-custom and changes may occur.

Suggested Tools and Instruments

Volt/Ohm Meter	Thermometer
Tachometer	Ammeter
Manometer (0-10" W.C.)	Microammeter
Standard Hand Tools	D.C Volt Meter
Gas Pressure Gauge (0-35 lbs.)	

NOTE: All servicing and adjustments of the Direct Gas-Fired unit should be performed by a qualified service engineer.

1. The owner's representative or equipment operator should be present during start-up to receive instructions on care and adjustments of the equipment.
2. Remove all shipping blocks, brackets and bolts from supply fan base with optional isolation base.
3. Check all wiring for loose connections and tighten if necessary.

CAUTION: Line side of disconnect may be energized.

4. Inspect all fan and motor bearings and lubricate if necessary. Tighten setscrews on pulleys, bearings, and fans.

CAUTION: Do not rupture grease seals.

5. Inspect pulleys and belts for tightness, tension and alignment. Do not over tighten belts.

6. Check set screws on all bearings, pulleys and fans for tightness.
7. Check voltage supplied to disconnect switch. The maximum voltage variation should not exceed $\pm 10\%$. Phase voltage unbalance must not exceed 2%.
8. Check thermostat(s) for normal operation.
9. Check that system duct work is installed and free from obstructions.
10. Check that fans turn free in housing.
11. Check burner for proper location and alignment.
12. Check that filters and accessories are installed correctly.
13. Check that vent lines have been run to atmosphere on indoor units. Note that some units will use vent limiters and vent lines are not required.
14. Check that all manual gas shut-off valves are closed.
15. When failure or malfunction of this heater creates a hazard to other fuel burning equipment, (e.g. when the heater provides make-up air to a boiler room), the heater is to be interlocked to open inlet air dampers or other such devices.
- 16. If inlet duct is attached to the heater, a purge timer must be provided and set to purge 4 times the inlet duct volume.**

$$\text{Purge time in seconds} = \frac{4 \times L \times W \times H \times 60}{\text{SCFM}}$$

L = duct length in feet, W = duct width in feet, H = duct height in feet, SCFM = rating plate air throughput.

Refer to the electrical schematic for the proper circuit placement. Purge timer P/N 65.0711.00.

SECTION V - UNIT START-UP

Close or replace all doors and service panels.

Turn main disconnect switch off. Verify the incoming line voltage matches the unit nameplate rating. If the voltage is over $\pm 10\%$ of nameplate rating or phase voltage unbalance is over 2%, notify the contractor or power company.

Turn Heat OFF/ON switch to the OFF position. Turn main disconnect switch on. Turn Fan OFF/ON switch to the ON position. Damper opens. Blower fan turns on.

Turn Fan OFF/ON switch to OFF position and check supply blower for proper rotation.

NOTE: To change rotation of the blower, simply interchange any two (2) of the line leads of the motor starter for three (3) phase motors. Refer to motor nameplate for reversing single (1) phase motors.

Turn Fan OFF/ON switch to the ON position. Check for proper blower rpm. Check that all motor amp draws do not exceed nameplate ratings, and the overload relay is set to the motor nameplate amperage.

Check dampers for proper operation. Be sure they operate freely, and the linkage does not bind.

Make sure all manual gas shut-off valves are in the closed position.

Turn Heat OFF/ON switch to the ON position. Blower fan will run.

Turn Fan and Heat OFF/ON switches to OFF position.

Setting Burner

NOTE: To adjust gas pressure on supply lines where a regulator has been installed (to reduce the inlet pressure to 1/2 PSIG or less), remove dust cap of main gas regulator and turn adjusting screw clockwise to increase pressure, or counter-clockwise to decrease pressure.

Set all thermostats to call for heat. Set inlet ductstat (if applicable) above outside air temperature.

Connect a DC microammeter between the SENSE terminal and the flame rod sensing wire.

Turn Fan and Heat OFF/ON switches to ON position.

Open inlet manual gas shut-off valve slowly. Reset high and (if applicable) low gas pressure switches. Check main gas line for leaks using soap solution.

Unit will run for 5 seconds before ignition trial.

NOTE: 3 OR 4 TRIALS MAY BE NEEDED TO PURGE AIR FROM GAS LINE.

United Technologies Electronic Controls Spark Ignitor Watch microammeter carefully. The reading should be at least 5.0 microamps. If the reading is too low, slowly turn the low-fire adjustment on the modulating valve in or out until satisfactory readings are obtained. When adjusting low fire, there should be a continuous flame along the entire burner length without any blowout spots.

Refer to Maxitrol Valve Adjustment instructions in Section IX for setting high and low fire gas pressure settings.

When the flame is adjusted, shut the unit off by turning the Fan and Heat switches to OFF.

Setting Main Flame

Install manometer at test port on the last tee of the burner manifold or modulating valve.

Slowly open all manual gas shut-off valves.

Restart unit. After main gas valves open and burner lights check gas lines for leaks.

Adjust high gas pressure reading (from manometer) to match firing rate shown on unit nameplate.

Adjust the high and low fire setting according to the Maxitrol Valve Adjustment instructions in Section IX. The high fire setting **must not** exceed the pressure stated on the rating plate.

When adjusting low fire, there should be a continuous flame along the entire burner length without any blow out spots.

Main flame is now set. Recheck the microamp signal on the ignition control throughout the full burner input range. Recheck low fire setting. Cycle unit 2 or 3 times to insure good ignition.

Safety Controls Check

A. High Temperature Limit and Firestats – These limit controls are not adjustable and are checked by the factory. Reset the red button(s) to be sure they are ready for operation. Contact the factory if these switches fail to reset.

B. Ignition Control - Operate unit in Heat mode. After flame has been established, close last manual gas valve before main burner. The ignition control must trip out within 15 seconds. Reset the ignition control by turning the HEAT switch to the OFF position.

- C. Gas Pressure Switches - Operate unit in Heat mode. The low pressure switch will trip out and must be reset before resuming operation when the inlet gas valve is turned off during operation. The high pressure switch may be checked out by reducing the setting of its trip point below unit operating pressure. It should then trip out and shut off the burner. Return the adjustment to its original setting and reset to resume operation.

When checking operation of gas pressure switches on systems without pilot the heat switch will have to be turned off for approximately five seconds to reset the ignition control.

- D. Air Pressure Switches - The high air pressure switch is checked by removing the sensing tube from the entering air side of the burner. Switch operation will shut off the burner. Recycle is automatic when the sensing tube is replaced. The low air pressure switch is checked by removing the sensing tube from the leaving air side of the burner. Switch operation will shut off the burner. Recycle is automatic when the sensing tube is replaced.

When checking operation of air pressure switches on systems without pilot the heat switch will have to be turned off approximately five seconds to reset the ignition control.

- E. Temperature Controls – These controls are checked by adjusting control settings to a lower temperature setting while the unit is operating on high fire and observing cutoff. The controls should be reset to settings shown below:

Suggested Control Settings

TC-01	Room Thermostat	Customer Discretion
TC-03	On-Off Inlet Ductstat	65°F
TC-08	Freeze Thermostat	3 min.,...45°F
PS-04	Low Gas Pressure Switch	1.0" w.c
PS-07	High Gas Pressure Switch.....	125% of firing rate
TC-09	Night Set Back Room	Customer Discretion
TC-52	Remote Temperature Selector	Customer Discretion
FL-02	High Temperature Limit (manual)	Not adjustable
RE-26	High Limit Discharge Ductstat	95°F
RE-26	Low Limit Discharge Ductstat	55°F
PS-12	Clogged Filter Switch	Adjust to Field Conditions
PS-13	Building Pressure Switch ..	Adjust to Field Conditions

SECTION VI - UNIT SHUTDOWN

A. Extended Shutdown -

1. Set the Heat OFF/ON switch to the OFF, then turn the Fan switch to the OFF position.
2. Close all manual gas valves.
3. Open the main electrical disconnect switch.

B. Emergency Shutdown ONLY -

1. Open the main electrical disconnect switch.
2. Close all manual gas valves.

SECTION VII – TROUBLESHOOTING

System without Pilot

Symptom	Cause	Remedy
A. If blower does not operate.	<ol style="list-style-type: none"> 1. Low or no voltage. 2. Fuse(s) blown. 3. Customer interlock not closed or connected. 4. Fan Off-On switch in Off position. 5. Time clock, night setback thermostat or field installed controls open. 6. Freeze protection tripped. 7. Damper motor not operating, or its end switch not making. 8. Overload protection on motor starter tripped. 9. Belts loose or broken 10. Bearings seized. 11. Motor may be burned or incorrectly wired. 12. Motor overheating. 	<ol style="list-style-type: none"> 1. Check power source. 2. Check and replace. 3. Close or connect customer interlock. 4. Switch to On position. 5. Check time clock, night setback thermostat and field installed controls for proper settings. 6. Reset freeze stat by interrupting power. Check for proper setting and burner operation. 7. Check for power at damper motor and that end switch has been wired correctly to the N.O. (normally open) contact. Check that the linkage is clear and not binding. 8. Push reset button on starter and check amps. 9. Turn power off and check belts. 10. Check and replace. 11. Turn power off and check motor and wiring. 12. Check burner firing rate.
B. If there is no voltage at ignition control.	<ol style="list-style-type: none"> 1. Heat Off-On switch in Off position. 2. Burner enable relay open (if applicable). 3. Outside air temperature higher than On-Off inlet ductstat (if applicable). 4. Field purge timer open (if applicable). 	<ol style="list-style-type: none"> 1. Switch to On position. 2. Check for power and replace if necessary. 3. Lower On-Off inlet ductstat setting. 4. Check for power and replace if necessary.
C. Burner does not light after 5 seconds pre purge of flame safeguard relay and there is voltage at ignition control.	<ol style="list-style-type: none"> 1. Manual gas shut-off valve closed. 2. Inlet gas pressure lower than required gas pressure. 3. Type of gas (Natural, LP) supplied different from factory required type. 4. Auxiliary switch on starter not closed. 5. Air flow switches not closing. 6. High temperature limit switch open. 7. High or low gas pressure switches open (if applicable). 8. Main gas valve relay open. 	<ol style="list-style-type: none"> 1. Slowly open valve. 2. Increase gas pressure. 3. Replace with factory required type of gas. 4. Check for power and replace if necessary. 5. Adjust the air flow and external static pressure to match rating plate. 6. Correct problem. Reset by pushing down the reset button. 7. Correct problem. Reset both switches. 8. Check for power and replace if necessary.

SECTION VII – TROUBLESHOOTING

System without Pilot *continued*

Symptom	Cause	Remedy
C. <i>continued</i>	9. Defective gas valve or actuator. 10. Defective spark rod or out of position. (see spark rod diagram #P-001004) 11. Flame rod not sensing flame. (see spark rod diagram #P-001003) 12. Defective regulator. 13. Blocked vent lines or vent limiters. 14. Low fire set too low or too high.	9. Check power to gas valves. If gas pressure matches unit rating plate and valve does not open, replace gas valve or actuator. 10. Make sure spark rod is producing a sufficient spark to light off burner; make sure porcelain is not cracked. Check wiring or replace if necessary. 11. Make sure flame rod is in flame. Make sure porcelain is not cracked. Check wiring or replace if necessary. 12. Clean or replace regulator. 13. Check vent lines or replace vent limiters. 14. Adjust setting on modulating valve or gas valve.
D. Burner will not respond to temperature.	1. For Maxitrol system. 2. For Honeywell system.	1. See following troubleshooting guide for Maxitrol series 14 & 44. 2. See following troubleshooting guide for Honeywell series.

SECTION VII - TROUBLESHOOTING

P-001004

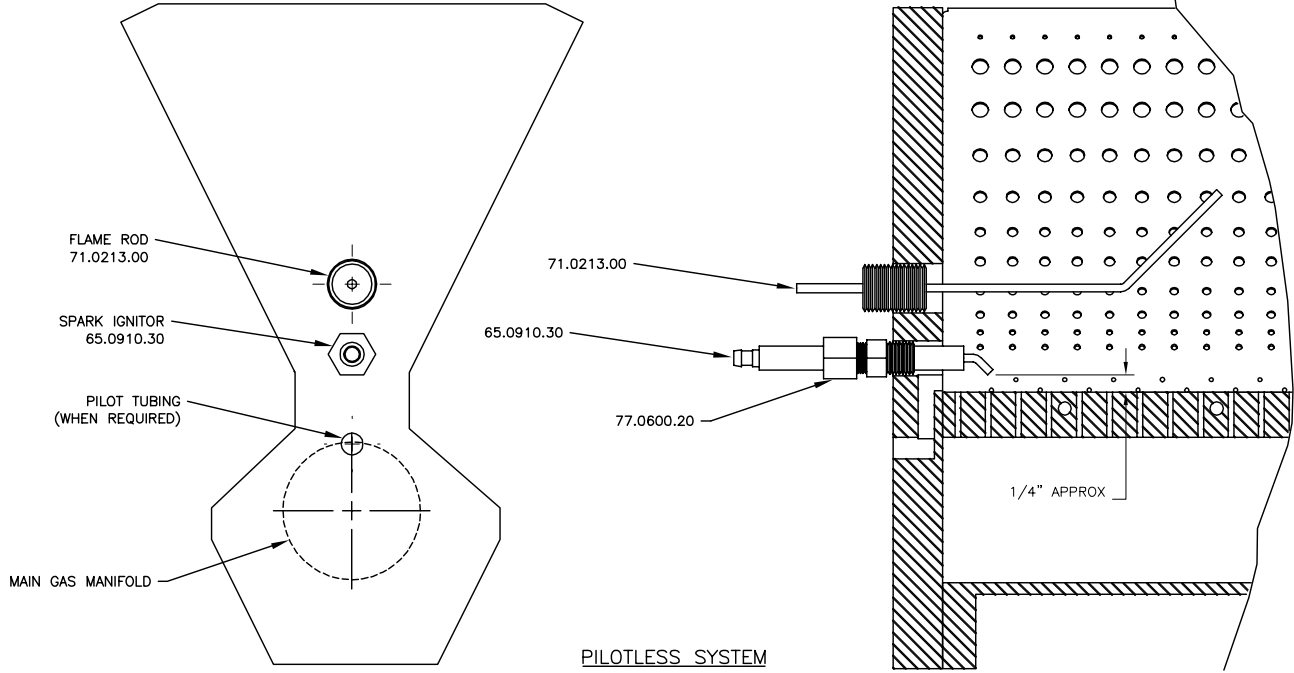
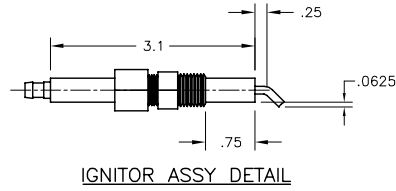

P-001003

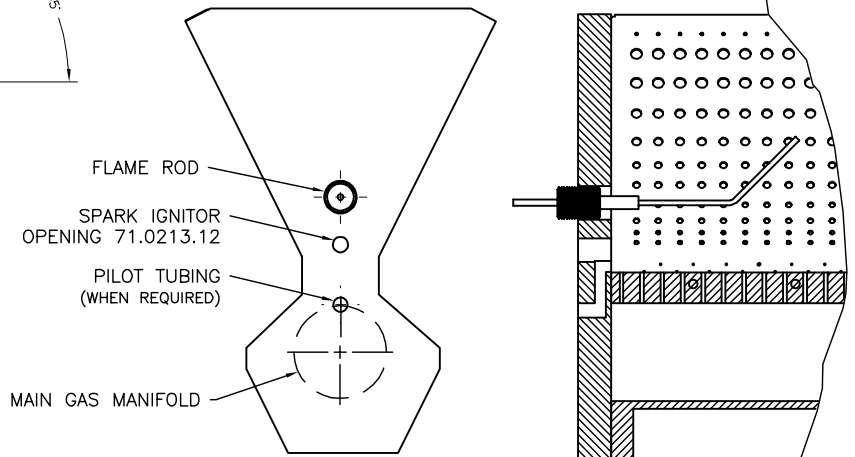
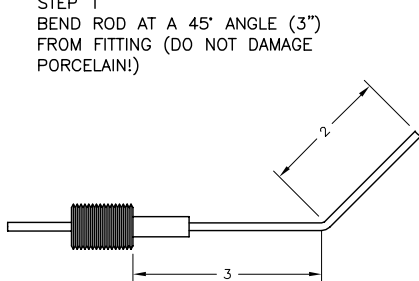
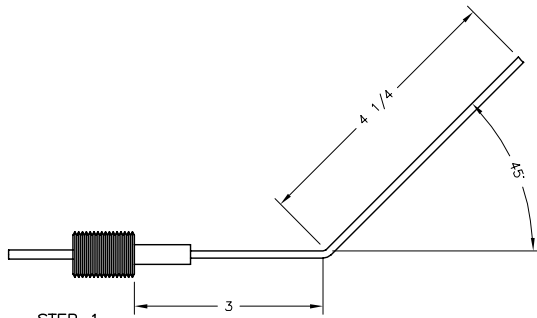
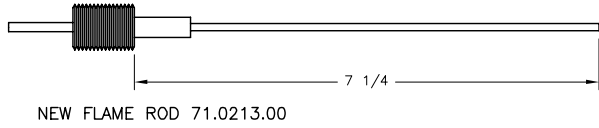

**United Technologies Electronics Controls
Operation of the Series 1016-400 Direct Spark
Ignition Control**

On a call for heat a five second pre-purge is initiated. Upon completion of the pre-purge, the gas valve and 60 Hz spark are energized. When flame is detected, the control enters the steady state heating condition. Steady state heating will continue until the call for heat is satisfied.

If ignition is not achieved within 15 seconds, the control shuts off the gas and locks out. If the trial for ignition has been accomplished without ignition, the control shuts off

all outputs and enters lockout. Reset is accomplished by cycling the power off for a minimum of 5 seconds. If flame is lost once it has been established, the control will shut off the gas valve within 0.8 seconds and locks out.

If flame is sensed during a purge period when no flame should be present, the control will remain in purge with the gas valve off until the false flame disappears. If the gas valve is found to be powered when it should be off, or not powered when it should be on, the control will enter lockout with all outputs off. Reset is accomplished by cycling the power off for a minimum of 5 seconds.

TROUBLESHOOTING GUIDE

Series 14 Discharge Temperature Control

Reproduced with permission from Maxitrol® Company

Symptom	Possible Cause	Field Test	Remedy
A. No Gas Flow	1. Modulating valve improperly installed (or see Symptom "L").	1. Arrow on side of valve should point in direction of gas flow.	1. Install properly.
B. Continuous Low Fire (Electronics Problem)	1. Short circuit or no voltage to the amplifier. 2. Open circuit in TD114 Remote Temperature Selector circuit or wiring. 3. Short circuit in TS114 Discharge Air Sensor circuit or wiring. 4. Faulty amplifier.	1. Check for 24V AC at amplifier terminals 7 & 8. 2. Inspect for loose or broken wires between amplifier terminals 1 & 2 and TD114 terminals 1 & 3. 3. Connect test resistor as described in Preliminary Circuit Analysis in Section IX. Follow procedures outlined. 4. Check items B1-3.	1. Prove the power source. 2. Tighten connections or replace wiring. 3. If modulating voltages are obtained, check TS114 circuit for shorts. Replace TS114 if necessary. 4. If items B1-3 check out, and modulating voltages are still not obtained, amplifier may be assumed faulty. Replace.
C. Continuous Low Fire (Electronics OK).	1. Short circuit or open circuit in Modulator Coil. 2. Plunger missing, jammed, or improperly installed.	1. Measure resistance across modulator terminals with connecting wires detached. 2. Inspect. Plunger should be installed to operate freely in solenoid sleeve.	1. Replace modulator head if not approximately 45-55 ohms for M611 Valve and 60-80 ohms for MR212 Valve. 2. Clean or replace plunger if necessary.
D. Incorrect Minimum Fire Erratic or Pulsating Flame	1. Incorrect by-pass metering valve adjustment. 2. Excessive negative burner pressure.	1. See valve adjustments in Section IX. 2. Close main gas supply and measure manifold pressure with blower operating. Reading should be less than 1.5" W.C. negative pressure.	1. Adjust to proper minimum fire. 2. If reading is greater than 1.5" negative pressure, check for clogged filters or other inlet air restrictions. Consult factory for other solutions.

TROUBLESHOOTING GUIDE

Series I4 Discharge Temperature Control *continued*

Reproduced with permission from Maxitrol® Company

Symptom	Possible Cause	Field Test	Remedy
E. Continuous High Fire (Electronics Problem).	<ol style="list-style-type: none"> 1. Short circuit in TD114 Remote Temperature Selector circuit or wiring. 2. Open circuit in TS114/TS1007 Discharge or Inlet Air Sensor circuit or wiring. 3. Jumper not connected across amplifier terminals 2 & 3. 	<ol style="list-style-type: none"> 1. Inspect for shorts at or between Amplifier terminals 1 & 2 or TD114 terminals 1 & 3. 2. Check TS114/TS1007 for open internal circuit. Connect test resistor as described in Preliminary Circuit Analysis. Follow procedure outlined. 3. Inspect. 	<ol style="list-style-type: none"> 1. Correct wiring if shorts exist. 2. If modulating voltages are obtained, check TS114/TS1007 for open circuits. Replace TS114/TS1007. 3. Correct the wiring.
F. Continuous High Fire (Electronics OK).	<ol style="list-style-type: none"> 1. Foreign object holding valve open. 2. Plunger jammed. 	<ol style="list-style-type: none"> 1. Remove bottom plate and inspect valve and seat. 2. Inspect. Plunger should be smooth and clean and operate freely in solenoid sleeve. 	<ol style="list-style-type: none"> 1. Clean seat. Clean valve or replace if necessary. 2. Clean or, if necessary, replace plunger
G. Incorrect Maximum Fire.	<ol style="list-style-type: none"> 1. Inlet pressure too low. 2. Incorrect outlet pressure adjustment of Pressure Regulator. 	<ol style="list-style-type: none"> 1. Read pressure at inlet to modulating valve using a manometer with unit operating at full fire. Pressure should be equal to the sum of outlet pressure setting plus pressure drop of the valve. 2. Read manifold pressure using manometer and compare with the pressure stated on the specification plate. 	<ol style="list-style-type: none"> 1. Increase inlet pressure if possible. 2. See valve adjustments in Section IX.
H. Erratic or Pulsating Flame	<ol style="list-style-type: none"> 1. Hunting 2. Erratic air patterns or improper TS114 location. 3. Wiring is run next to high voltage switching circuits causing induced voltages. 	<ol style="list-style-type: none"> 1. Adjust sensitivity control counter-clockwise. 2. Connect test resistor as described in Preliminary Circuit Analysis. Turn TD114 selector dial so heater goes through its entire modulating range. 3. Temporarily wire each TD114, TS114 and MR212 externally and observe heater/equipment operation. 	<ol style="list-style-type: none"> 1. If flame stabilizes, adjust sensitivity control to maintain an even flame. 2. If the flame is steady throughout the entire modulating range, the TS114 must be moved. 3. If smooth operation results, isolate affected wiring from source of induced voltage.

TROUBLESHOOTING GUIDE

Series I4 Discharge Temperature Control *continued*

Reproduced with permission from Maxitrol® Company

Symptom	Possible Cause	Field Test	Remedy
H. <i>continued</i>	4. Faulty Amplifier or erratic voltage supply.	4. With test resistor connected (per item H2) and TD114 locally connected (per item H3) turn TD114 selector dial through entire modulating range. Observe D.C. voltage across modulator terminals.	4. If erratic or unstable D.C. voltages are obtained throughout the modulating range, the amplifier may be assumed faulty. Replace. If erratic operation is noted only over a small range of 2 or 3 volts, the voltage sources may contain surges. Consult factory for other solutions.
I. Incorrect Discharge Air Temperature	1. Inlet Air sensor is used. 2. Incorrect wiring. 3. System out of calibration. 4. Improper TS114 location. 5. Room Override Thermostat circuit closed.	1. Inlet Air Sensor changes 1° or each 3.5°, 5° or 8° outside temperature change from 60° (predetermined - turndown varies with model used). 2. Check wiring diagram for heater. 3. Sensed temperature (thermometer next to TS114) does not correspond to TD114 setting. 4. Sensed temperature (thermometer next to TS114) does not represent average discharge air temperature. 5. Remove Override Thermostat lead from terminal 2 of TD114.	1. Sensed temperature will vary from TD114 dial settings. This is intentional. 2. Correct wiring. 3. See calibration procedure. 4. Move TS114 to location where average representative temperature can be sensed. 5. TD114 dial setting, then check thermostat setting and/or check wiring for shorts.
J. Burned out Transformer.	1. Short circuit in modulator coil. 2. Short circuit between amplifier and modulator valve.	1. Measure resistance across modulator terminals with red lead wires disconnected. 2. Inspect wiring.	1. Replace modulator head if less than 40 ohms. 2. Correct wiring if short is found.
K. Discharge Air Temperature too low when TS115 is operative.	1. Override Temperature setting is too low. 2. Burner capacity may be insufficient.	1. Check "Override Temperature Selector" of TD114. 2. Check for high fire (Maxitrol manifold pressure specified for heater).	1. Reset to correct temperature. 2. If on high fire, control can do no more. Heater unable to furnish additional heat to raise temperature.
L. Automatic Control Valve will not open despite full range of modulating voltage at terminals 3 & 4.	1. Faulty automatic control valve. 2. Open wire to automatic valve.	1. Read voltage across auto valve terminals. If 24V AC, valve is faulty. 2. Read voltage across terminals 5 & 6. If 24V AC, check for open circuit to automatic valve.	1. Replace automatic control valve. 2. Correct wiring.

TROUBLESHOOTING GUIDE

Series 44 Room Temperature Control

Reproduced with permission from Maxitrol® Company

Symptom	Possible Cause	Field Test	Remedy
A. No Gas Flow.	1. Valve improperly installed.	1. Arrow on side of valve should point in direction of gas flow.	1. Install properly.
B. Continuous Low Fire (Electronics OK).	1. Open circuit in modulator coil. 2. Plunger missing, jammed or improperly installed. 3. Ruptured main or balancing diaphragm.	1. Remove wires connected to amplifier terminals 6 & 7 and measure resistance. MR212 (60-80 ohms), M611 (45-55 ohms). 2. Inspect. Plunger should be installed to operate freely in solenoid sleeve. 3. Disassemble valve for inspection of internal parts.	1. If proper resistance values are not observed, replace modulator head or repair wiring. 2. Clean or replace plunger is necessary. 3. Replace diaphragm if ruptured.
C. Continuous Low Fire (Electronics Problem).	1. No voltage to the amplifier. 2. Short in modulator coil circuit. 3. Short in TS144 circuit. 4. Faulty amplifier.	1. Check for 24V AC at amplifier terminals 8 & 9. 2. Measure resistance per item 2. 3. Remove wires connected to amplifier terminals 1, 2 & 3. Measure resistance across wires 1 & 3. Meter should read greater than 2500 ohms. 4. Follow procedures outlined in "Preliminary Circuit Analysis" in Section IX.	1. Provide 24V AC to amplifier. Refer to item K1. 2. If proper resistance values are not observed, replace the modulator head or repair wiring. 3. If readings are incorrect, replace the TS144 or repair wiring. 4. If power source and modulator coil check out (items 5 & 6) but proper modulating voltages cannot be obtained, then amplifier may be assumed at fault. Install replacement amplifier.
D. Incorrect Low Fire.	1. Incorrect by-pass metering valve adjustment. 2. Excessive negative burner pressure.	1. See Valve Adjustments - Section IX. 2. Close main gas supply and measure manifold pressure with blower operating. Should be less than 1.5" W.C. negative pressure.	1. Adjust to proper low fire. 2. If greater than 1.5" negative pressure, check equipment for clogged filters and other inlet air restrictions. For other solutions, consult factory.
E. Continuous Minimum Discharge Air Temperature.	1. Faulty amplifier. 2. Short in T244 or TS244/TD244 circuit.	1. Follow procedures outlined in "Preliminary Circuit Analysis" in Section IX. 2. Remove wires connected to amplifier terminals 4 & 5. Set T244 or TD244 to maximum setting. Measure resistance across wires. Meter should read 6000 ohms \pm 1000 (T244). If TS244/TD244 are used, meter should read 4500 ohms \pm 1000 (TS244) and 2100 ohms \pm 150 (TD244).	1. If amplifier is proven at fault, install replacement amplifier. 2. If reading is incorrect, replace The T244, TS244/TD244 or repair wiring.

Control circuits external to Series 44 can cause burner malfunction. Always check manual valve to be certain gas is on, and check limit controls for normal operation.

TROUBLESHOOTING GUIDE

Series 44 Room Temperature Control *continued*

Reproduced with permission from Maxitrol® Company

Symptom	Possible Cause	Field Test	Remedy
E. <i>continued</i>	3. Incorrect space temperature calibration.	3. Follow procedures outlined in "Preliminary Circuit Analysis" in Section IX.	3. If proper action is obtained, first check item E2. Recalibrate if necessary.
F. Incorrect Maximum or Minimum Discharge Air Temperature.	1. Improper TS144 location. 2. Incorrect discharge air temperature calibrations.	1. Compare sensed temperature reading at TS144 with average discharge air temperature. 2. Follow procedures outlined in "Preliminary Circuit Analysis" in Section IX.	1. Move TS144 to location where average temperature can be sensed. 2. If proper temperatures are not observed, refer to Discharge Air Temperature calibration procedures.
G. Continuous High Fire (Electronics OK).	1. Foreign material holding valve open. 2. Plunger jammed.	1. Remove bottom plate and inspect valve and seat. 2. Inspect. Plunger should be smooth and clean and operate freely in solenoid sleeve.	1. Clean, replace valve and/or seat if necessary. 2. Clean, or if necessary, replace plunger
H. Continuous High Fire (Electronics Problem).	1. Open circuit in TS144.	1. Measure resistance per item C3.	1. If readings are incorrect, replace the TS144 or repair wiring.
I. Incorrect High Fire	1. Inlet pressure too low. 2. Incorrect outlet pressure adjustment.	1. Read inlet pressure at valve using manometer with heater operating at full fire. Pressure should be at least equal to the sum of: outlet pressure setting and pressure drop of the valve plus 1.0" W.C. 2. Read outlet pressure using manometer and compare with the pressure stated on the specification plate.	1. Increase inlet pressure if possible or change to larger valve. Consult factory about possibility of using special spring to reduce pressure drop on selected installations. 2. See Valve Adjustments in Section IX.
J. Continuous Maximum Discharge Air Temperature.	1. Faulty amplifier. 2. Open circuit in T244 or TS244/TD244. 3. Incorrect space temperature calibration.	1. Follow procedures outlined in "Preliminary Circuit Analysis" in Section IX. 2. Measure resistance per item E2. 3. Follow procedures outlined in "Preliminary Circuit Analysis" in Section IX.	1. If amplifier is proven at fault, install replacement amplifier. 2. If reading is incorrect, replace T244, TS244/TD244 or repair wiring. 3. If proper action is obtained, first check item J2. Recalibrate if necessary.
K. Burned out Transformer. No Voltage to Amplifier.	1. Short in modulator coil circuit.	1. Measure resistance per item B1.	1. If proper resistances are not observed, replace modulator head or repair wiring.

Control circuits external to Series 44 can cause burner malfunction. Always check manual valve to be certain gas is on, and check limit controls for normal operation.

TROUBLESHOOTING GUIDE

Series 44 Room Temperature Control *continued*



Reproduced with permission from Maxitrol® Company



<p>L. Incorrect Space Temperature</p>	<ol style="list-style-type: none"> 1. Incorrect maximum discharge air temperature setting (A1044). 2. Incorrect minimum discharge air temperature setting (A1044). 3. Insufficient burner capacity. 4. Incorrect space temperature calibration. 	<ol style="list-style-type: none"> 1. Check to see if heater is delivering air at maximum discharge air setting. 2. Check to see if heater is delivering air at minimum discharge air setting. 3. Check to see if heater is operating at high fire. 4. Place thermometer next to T244 or TS244. Compare space temperature reading with T244 or TD244 dial setting. 	<ol style="list-style-type: none"> 1. If desired temperature is not reached, increase maximum discharge air temperature setting. 2. If desired space temperature is not reached, decrease minimum discharge air temperature setting. 3. If desired space temperature is not reached with heater at high fire, it may be undersized. 4. Consult factory. If temperature reading is incorrect, check items L1, L2 & L3, then recalibrate if necessary.
---------------------------------------	---	--	--

Control circuits external to Series 44 can cause burner malfunction. Always check manual valve to be certain gas is on, and check limit controls for normal operation.

Honeywell Two Stage Valve

Two-stage models require that you check and adjust both high and low pressure regulator settings. Two-stage appliance operating sequences vary. Consult the appliance manufacturer instructions for the specific operating sequence and regulator adjustment procedure for the appliance in which the control is installed.

1. Set appliance to operate on high.
2. Carefully check the main burner lightoff. Make sure that the main burner lights smoothly and that all ports remain lit.
3. Check the full rate (high) manifold pressure listed on the appliance nameplate for high pressure. The gas control full rate outlet pressure should match this rating.
4. With main burner operating, check the gas control flow rate using the meter clocking method or check pressure using a manometer connected to the outlet pressure tap on the gas control.
5. If necessary, adjust the high pressure regulator to match the appliance rating.
 - a. Remove the pressure regulator adjustment cap.
 - b. Using a screwdriver, turn the inner adjustment screw for HI pressure clockwise  to increase or counterclockwise  to decrease the gas pressure to the burner.
6. After high pressure has been checked, check low pressure regulation. Two-stage appliance operating sequences vary. Consult the appliance manufacturers instructions for the specific operating sequence and regulator adjustment procedure for the appliance in which the control is installed and for instructions on how to prevent the control from moving to high stage while checking the low pressure regulator setting.
7. Check the low rate manifold pressure listed on the appliance nameplate. Gas control low rate outlet pressure should match this rating.

8. With main burner operating, check the gas control flow rate as before (using the meter clocking method or check pressure using a manometer connected to the outlet pressure tap on the control).
9. If necessary, adjust the low pressure regulator to match the appliance rating.
 - a. Remove the pressure regulator adjustment cap.
 - b. Using a screwdriver, turn the inner adjustment screw for LO pressure clockwise  to increase or counterclockwise  to decrease the gas pressure to the burner.
10. Once high and low pressure have been checked and adjusted, replace pressure regulator adjustment cap. If the desired outlet pressure or flow rate can not be achieved by adjusting the gas control, check the control inlet pressure using a manometer at the inlet pressure tap of the control. Take the necessary steps to provide proper gas pressure to the control.

Check Safety Shutdown Performance

WARNING: Fire or explosion hazard. Can cause property damage, severe injury or death. Perform the safety shutdown test any time work is done on a gas system.

NOTE: Read steps 1 through 7 before starting, and compare to the safety shutdown or safety lockout tests recommended for the intermittent pilot (IP) ignition module. Where different, use the procedure recommended for the module.

1. Turn off gas supply.
2. Set thermostat or controller above room temperature to call for heat.
3. Watch for ignition spark or for glow at hot surface igniter either immediately or following prepurge. See IP module specifications.
4. Time the length of the spark operation. See the IP module specifications.

5. After the module locks out, open the manual gas cock and make sure no gas is flowing to the pilot or main burner. *With modules that continue to spark until the pilot lights or the system shuts down manually, the pilot should light when the manual gas control knob is opened.*
6. Set the thermostat below room temperature and wait one minute.
7. Operate system through one complete cycle to make sure all controls operate properly

SECTION VIII - MAINTENANCE SCHEDULE AND LUBRICATION REQUIREMENTS

Periodic maintenance is essential to the efficient operation and extended service life of this equipment. Failure to provide maintenance as recommended may void the equipment warranty.

A. Maintenance Schedule

1. Weekly

- a. Check that fan belts are tight and sheaves are aligned. The fan belts can be checked every 30 days after the first 60 days of new belt run-in.

CAUTION: Do not overtighten belts.

2. Monthly

- a. Check all valves, piping and connections for leaks.
- b. Check the flame signal.
- c. Check the fuel pressure in the fuel supply line to each heater.
- d. Check the burner manifold pressure at full fire and that low fire has a continuous flame all across burner.
- e. Clean the flame sensor(s).
- f. Inspect filters. Clean or replace as necessary.
- g. Inspect the main fan bearings.
- h. Check all dampers, damper actuators and linkages. Adjust and tighten if necessary.
- i. Ensure that there are no obstruction blocking the air supply to the heater or the air discharge from the heater.
- j. Inspect the area and make sure that no combustible or hazardous material has been stored within the clearances as shown on the unit nameplate.

3. Quarterly

- a. Complete the monthly maintenance schedule.
- b. Check the belt tension for the main fan(s) and adjust if necessary.
- c. Check the alignment of the sheaves and adjust if necessary.
- d. Inspect all bearings set screws for tightness and lubricate bearings if necessary.
- e. Check the pilot electrical system (if applicable). Adjust if necessary.

- f. Check the pilot assembly (if applicable). Clean and adjust if necessary.
 - g. Inspect the burner carefully. Clean and adjust if necessary.
 - h. Check voltages and amp draw on main fan motor.
 - i. Check the operation of all safety controls individually.
 - j. Check the operation of the automatic gas shut off valves and check them for leakage at the pressure test ports provided.
- #### 4. Off Season or Yearly
- a. Complete the monthly and quarterly maintenance schedule.
 - b. Inspect all fan wheels and housings. Clean if necessary.
 - c. Check that all fan wheels and sheaves are securely set on the shaft.
 - d. Inspect all bearings and alignment. Adjust if necessary.
 - e. Inspect all V-belts. Replace if necessary.
 - f. Inspect all electrical components, connections and terminals. Clean and tighten where necessary.
 - g. Test ignition spark. Adjust gap if necessary.
 - h. Clean ignition electrodes and check for cracks.
 - i. Test flame safeguard relay and replace components if necessary.
 - j. Inspect all regulators, relief valves, motorized valves, solenoid valves, vent valves, manual shut off valves and safety shut off valves. Check their operation and clean as necessary.
 - k. Ensure all vents to the atmosphere are clean and free from obstruction.
 - l. Inspect and clean all drip legs in the fuel line.
 - m. Lubricate fan motor as directed by motor manufacturer.
 - n. Inspect fan motor wiring for loose connections.
 - o. Lightly oil all door latches.
 - p. Check that cabinet is weathertight, replace door gaskets and recaulk as necessary.

NOTE: Keep screened air intakes clear of obstructions at all times.

B. Lubrication Instructions

Item	Manufacturer	Bearing Type
All 3 phase fan motors (1 HP to 20 HP) ODP,TEFC	U.S., Baldor or equal	Single row ball bearings
<i>Recommendation: See following note.</i>		
All 1 phase motors (Fractional HP) ODP,TEFC or TEAO	Century, G.E. or equal	Bronze sleeve bearings
<i>Recommendation: See following note.</i>		
Fractional HP single phase, ODP or TEFC	Century, G.E. or equal	Bronze sleeve bearings
<i>Recommendation: See following note.</i>		
Fan shaft bearings	Fafnir or equal	Self-aligning single row ball bearings, resilient mounted
<i>Recommendation: See following note.</i>		
Dampers	Arrow or equal	Sleeve
<i>Recommendation: See following note.</i>		

1. Blower Motors - Some motors require lubrication while others do not. Those that require lubrication can be identified by the presence of grease plugs in the motor casing at each end. Motors that do not have grease plugs cannot be greased and are lubricated for the life of the motor bearing.

Lubrication of motors should be done while the motor is warm and at a standstill. Remove and clean all grease plugs and insert a grease fitting in the upper hole in the motor casing at each end. (Viewed as if motor were sitting horizontally on its base.) There may be one or two plugs in each end casing of the motor. Add a small amount of a clean, good grade ball bearing grease, such as Exxon Polyrex EM or equal, with a low pressure grease gun. Run the motor five minutes before removing the grease fittings and replacing the plugs.

CAUTION: An excess of grease will overheat the bearings.

NOTE: On totally enclosed fan cooled (TEFC) motors, the rear end fan housing must be removed to expose the grease plugs.

2. Pillow Block Bearings - Pillow block bearings are used on supply blower(s) as required. Bearings have been pre-lubricated with a number 2 lithium base grease. Relubrication should be done with a similar grease using a low pressure grease gun. Wipe all grease fittings clean before adding grease. Grease should be added slowly, in small amounts at frequent intervals while the shaft is being manually rotated.

A slight showing of grease at the seals with accompanying normal bearing temperature indicates proper lubrication. Normal temperature can range from “cool” to “hot to the touch” depending on size, speed and surrounding conditions. Excessive bearing temperature indicates faulty lubrication. An insufficient amount of grease is suggested by a bearing showing no grease at the seals, and a higher than normal temperature and noise level. Excessive leakage of grease at the seals, and a high operating temperature suggest too much grease.

Frequency of Lubrication - Frequency of lubrication depends upon operating conditions. The bearing operating temperature is the best index for determining a relubrication schedule. The following chart gives the frequency of relubrication based upon continuous operation for various operating temperatures and can be used as a satisfactory guide for determining when all ball bearings should be relubricated.

Speed	Temperature	Cleanliness	Interval
500 RPM	Up to 150°F	Clean	2 months
1000 RPM	Up to 210°F	Clean	2 weeks
1500 RPM	Over 150°F	Clean	weekly
Any Speed	Up to 150°F	Dirty	1 week to 1 month
Any Speed	Over 150°F	Dirty	daily to weekly
Any Speed	Any Temp.	Very Dirty	daily to weekly
Any Speed	Any Temp	Extreme Conditions	daily to weekly

3. Dampers - Dampers should be inspected monthly for securely fastened linkages and smooth operation. If dampers are binding or excessively noisy, lubrication may be required. Place one drop of #20 wt. machine oil on each blade bearing and linkage ball joint. Do not over lubricate. Wipe away any excess from the area. Be sure to note that dampers over 49 inches long have intermediate bearings which require lubrication.

C. Air Filters

All filter banks should be equipped with a manometer or differential pressure switch to indicate when the filters are dirty. Filters should be replaced when the differential pressure across them reaches the manufacturer’s recommended final value. Dirty filter elements should be replaced with a clean element of the same type and size. In addition, the manufacturer strongly recommends, that air filters be **checked every 30 days** and replaced with new filters (throw-away type) or cleaned (washable type) as required. Cleanable filters should be given new application of filter coating after washing to maintain optimum filter performance.

The frequency of cleaning and replacing air filters applies twelve months of the year where blowers are used for ventilation and heating.

D. Belt Tension and Adjustment

Belt tension is adjusted during the initial run-in and test periods at the factory. However, the belts are run as slack as possible to prevent excessive damage to the bearings, yet tight enough to prevent slippage.

It is necessary, therefore, to check belt tension during the first few months of operation, and to **check for proper tension weekly during the first 60 days**, after which 30-day check intervals are sufficient.

CAUTION: Turn off all power to the equipment before checking belt tensions.

CAUTION: Do not over tighten belts.

CAUTION: Do not attempt to tighten any belt or belts by changing the pitch of an adjustable pulley. This will change the air flow and fan speed. Consult the factory if the fan speed must be changed.

Suggested Belt Tension Method

1. Check tension frequently during the first 24-48 hours of run-in operation. Ideal tension is the lowest tension at which the belt will not slip under peak load conditions. Over tensioning shortens belt and bearing life.
2. To properly tension a conventional V-belt drive, use the following procedure:
 - a. Measure the span length.
 - b. At the center of the span, apply a force perpendicular to the span to deflect the belt 1/64 inch for every inch of span length. For example, for a 40 inch span, apply a force that will deflect the belt 40/64 or 5/8 of an inch.
 - c. Compare the force you have applied with the values given in the table below. If the force is between the values for normal tension and 1 1/2 times normal tension, the belt tension should be satisfactory. If the belt tension is not within this range, it can be adjusted by loosening the motor mounting bolts and adjusting the position of the motor along its base.

NOTE: A new drive can be tightened to two times the minimum value shown to allow for normal drop in tension during the run-in period.

B Section small pulley diameter range in inches	Belt Manufacturer & Type Belt	Pounds Force for Normal Tension	Pounds Force for 1 1/2 times Normal Tension
3.4-4.2	Gates Hi-Power	4.4	6.6
4.4-4.6	Gates Hi-Power	4.9	7.4
5.8-8.6	Gates Hi-Power	5.8	8.7

Note: For recommendation of other types of belts, consult respective manufacturers.

F. Gaskets

Gaskets are used on doors, inspection covers, some filter racks, and some outdoor air dampers. Inspect gaskets periodically and repair or replace as required.

G. Heater

1. At least a yearly inspection is recommended for heating installations and more frequently for process applications in year-round operation. Your own experience is the best guide in determining frequency of inspection, but as a minimum, the following procedure should be followed:
 - a. Shut the system down totally, disconnecting or locking out power supply so there can be no accidental start-up during inspection.
 - b. Inspect the burner carefully, including upstream and downstream sides of mixing plates as well as burner body face. Note that complete burner assembly may have to be removed for proper inspection and cleaning. Any accumulation of scale or foreign material on either side of the mixing plates should be removed with a wire brush. Check visually that no holes in the mixing plates are blocked. If any burner ports are plugged, even partially, clear them with a piece of wire. Consult the factory for alternate procedures.

WARNING: Do not enlarge burner ports or performance may be drastically affected.

If any mixing plates are loose or missing fasteners, tighten or replace as necessary. Always use zinc plated or stainless fasteners.

The mixing plates on the burner may display "hairline" cracks. These cracks are normal and caused by thermal stresses occurring during combustion. The presence of these "hairline" cracks in no significant way affects the combustion efficiency or performance of the heater. Should a large opening develop, it may cause difficulties in cross ignition of flame across the face of the burner. If this does occur, the specific mixing plate or plates involved **must** be replaced.

- c. Put system back into operation and view burner while cycling through full firing range. This will give a visual check for blocked burner ports. Clean burner ports as necessary using a #47 drill. Burner plates should be cleaned with a wire brush at least once a year.
2. Inspect the flame rod and ignition electrode for dirt and moisture. Wipe off if necessary. Examine for any evidence of premature arcing. If in doubt, check continuity of flame rod to be sure it is not grounding out. Replace if required.

The porcelain on the ignition electrode must be intact, not cracked.

3. Replace all access panels, which have been removed, and operate the unit for a test period. Check for normal response and function of all controls.
4. Check all gas piping for possible leaks using a soap bubble solution.
5. Inspect the support means to be sure that everything is firmly anchored in place.

SECTION IX - MAXON NP-I AIRLO® BURNERS

Inspection and Maintenance of Gas Ports

Conduct initial inspection within the first month after commissioning. Visually check the gas ports of new burner assemblies for any piping scale or debris. Use Pin Vise with drill bit to remove.

Annual inspections are normally adequate once the initial piping debris is removed. The operating conditions of the burner will determine how frequently maintenance is actually required.

Use of an electric drill motor is not suggested unless both Pin Vise and Drill (as shown) can be chucked up in a variable speed drill unit. Use caution, because it is easy to snap the bits off in a port when using a drill motor. Removal of broken bits from the gas ports is difficult.

Alternate drill sizes which may be used are 5/64" (for #47) and 1/16" (for #50).

Contact your Maxon representative to answer questions or address any problems.

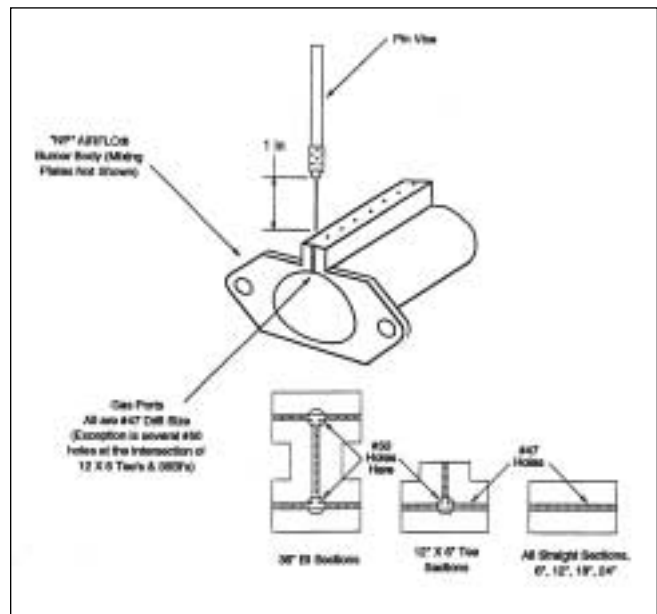

SECTION X - MAXITROL VALVE ADJUSTMENTS AND PRELIMINARY CIRCUIT ANALYSIS

MR212 Valve

High Fire Manifold Adjustments

1. Disconnect wires from amplifier terminal #4 (Series 14), or #2 and #4 (Series 44). This causes the valve to call for continuous high fire.
2. Remove seal cap (A) and turn regulator pressure adjusting screw to obtain desired manifold pressure. (Clockwise rotation increases pressure.)
3. Reconnect the wires to amplifier terminal #4 (Series 14), or #2 and #4 (Series 44).

NOTE: If low bypass is on maximum, the desired high fire outlet pressure may not be achieved.

Low Fire or Bypass Adjustments

1. Disconnect wire from amplifier terminal #8. This causes valve to call for continuous low fire.
2. Remove cap (B) and loosen lock screw (C). Turn (D) to desired low fire adjustment. (Clockwise rotation reduces minimum flow rate.)
3. Tighten screw (C), replace cap (B) and reconnect wire to amplifier to terminal #8.

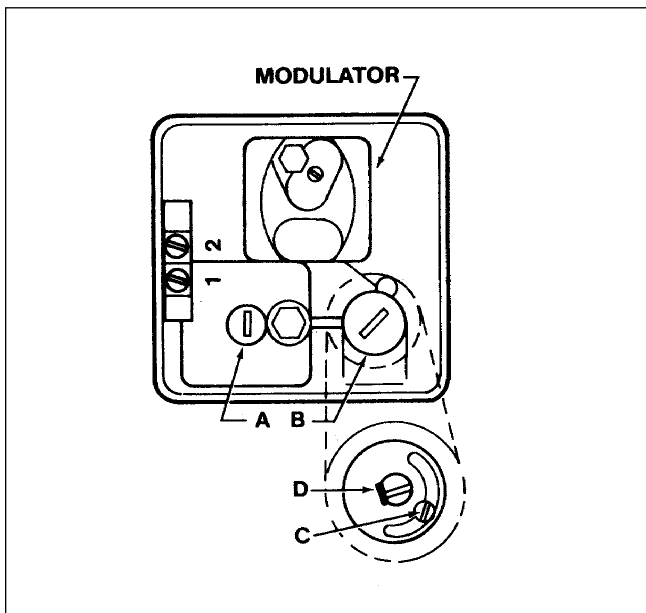

M411, 511, 611 Valve

High Fire Manifold Adjustments

1. Disconnect wires from amplifier terminal #4 (Series 14), or #2 and #4 (Series 44). This causes the valve to call for continuous high fire.
2. Adjust the pressure regulator to obtain the rating plate manifold pressure.
3. Reconnect the wires to amplifier terminal #4 (Series 14) or #2 and #4 (Series 44).

Low Fire or Bypass Adjustments

1. Disconnect wire from amplifier terminal #8. This causes the valve to call for continuous low fire.
2. Remove cap (A) and turn adjusting screw (B) to desired low fire adjustment. (Clockwise rotation reduces minimum flow rate.)
3. Replace cap (A) and reconnect wire to amplifier terminal #8.

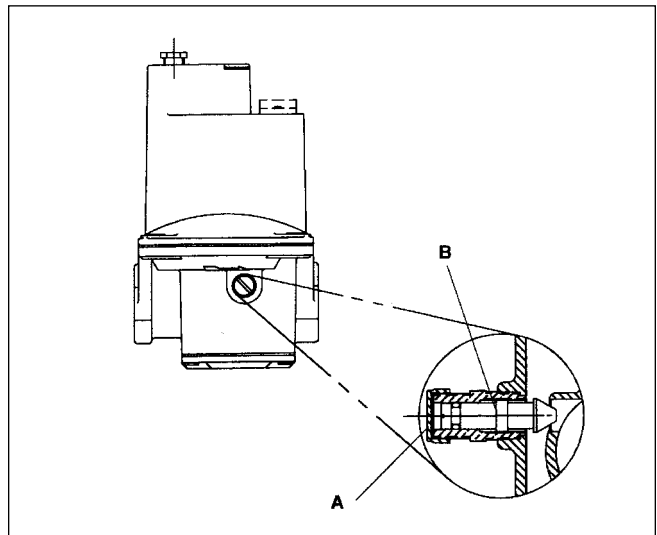

PRELIMINARY CIRCUIT ANALYSIS - SYSTEM 14

For ease in troubleshooting, it is advisable to wire the system as follows (this differs from the normal connection). The Discharge Air Sensor is disconnected and replaced with a 10,000 ohm, 1/2 watt test resistor (terminals 3 and 4). If inlet air sensor is being used, disconnect and replace with a jumper. On units where the Remote Temperature Selector is located a considerable distance from the heater, it may be advantageous to connect the selector at the heater location.

Connect a DC volt meter (capable of reading 0-24V DC) on the Modulator or Modulator-Regulator Valve terminals. Set the temperature to the minimum dial setting. The DC voltage should read 0 volts. The DC voltage should gradually increase to at least 20 volts as you slowly rotate the dial to the maximum dial setting. If these voltages are obtained, the valve function can now be checked out.

The operation of the valve with regard to voltage is as follows: from 0 volts to approximately 5 volts, the modulating valve should be on bypass flow with the heater operating on low or minimum fire. From approximately 5 volts to 15 volts DC, the valve should be performing its modulating function and the heater should be firing at a modulated flow rate between low and high fire, depending on the voltage. Above approximately 15 volts DC, the valve should be delivering full flow to the heater and the unit should be on full fire. If the DC voltage is obtained on the valve terminals, but the heater does not respond as described, the problem can be isolated to the valve itself or to the gas control manifold of the heater.

In the event proper voltages are obtained and the valve responds correctly to these DC voltages, the problem could well be in the wiring leading to the Discharge Air Sensor itself. This should also be reviewed in the check list.

If the proper voltages are not obtained when wired as instructed, the problem can be isolated to the electronics and this may once again be reviewed in the check list. After test, remove the test resistor and reconnect the Discharge Air Sensor to terminals 3 and 4. If Remote Temperature Selector has been moved, return it to its original position.

PRELIMINARY CIRCUIT ANALYSIS - SYSTEM 44

This Preliminary Circuit Analysis will provide identification of faulty components, improper wiring or calibration, and other difficulties when used with the tabulated Troubleshooting Guide.

NOTE: All voltages and resistance readings are approximate.

Section 1

1. Wire the system per Figure 1.
2. Connect a DC voltmeter to amplifier terminals #6 and #7.
3. Turn the Test-Potentiometer to minimum resistance (2,000 ohms). The DC voltage should read 0 volts.
4. Turn the Test-Potentiometer slowly to maximum resistance (12,000 ohms). The DC voltage should gradually increase to at least 18 volts.

If proper voltages are observed, continue on with Section 2.

If proper voltages are not observed, the problem is identified with the Amplifier, the 24-volt AC power supply, or the circuit connected to terminals #6 and #7.

Section 2

1. Turn power OFF. Wire system per Figure 2. Turn power ON.
2. Turn Test-Potentiometer to minimum resistance. Voltage should be 0 volts.
3. Turn Test-Potentiometer slowly to maximum resistance. The DC voltage should gradually increase to at least 18 volts.

If proper voltages are observed in both Section 1 and 2, the amplifier is satisfactory.

If proper voltages are not observed, continue testing to identify the difficulty. Faults may be identified with the amplifier, the 24V power supply, or the circuit connected to terminals #6 and #7.

Section 3

1. Observe burner flames and/or burner pressure as Test-Potentiometer is turned through full range.

NOTE: From 0-5 volts, heater should be at bypass or low; 5-15 volts, heater should respond with various input rates; beyond 15 volts, heater is at maximum input.

If proper operation is observed, continue procedure to check operation of sensing and selecting components. If proper operation is not observed, see Trouble-shooting Guide to test M and MR valves and connecting wiring.

Section 4

1. With proper voltages observed thus far and modulator responding correctly, wire the system (see Figure 1), except have TSI44 connected in place of jumper. Set A1044 MIN temperature selector at least 10°F above outdoor temperature. Set A1044 MAX temperature selector at mid-range. Heater is now under control by TSI44 Discharge Air Monitor.
2. Turn Test-Potentiometer to maximum resistance. Delivered air temperature should be per A1044 MAX temperature setting. Turn Test-Potentiometer to minimum resistance. Delivered air temperature should be per A1044 MIN temperature setting. If proper delivered air temperatures are observed, the problem is identified with the space temperature sensing and/or temperature selecting components and circuits. See Troubleshooting Guide. If proper delivered air temperatures are not observed, check calibration. See Troubleshooting Guide.

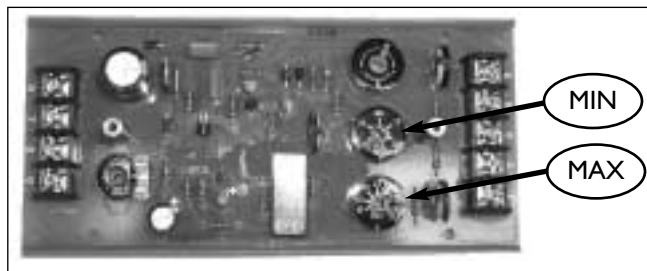

Section 5

1. After test, remove all test equipment and reconnect all components.

Figure 1

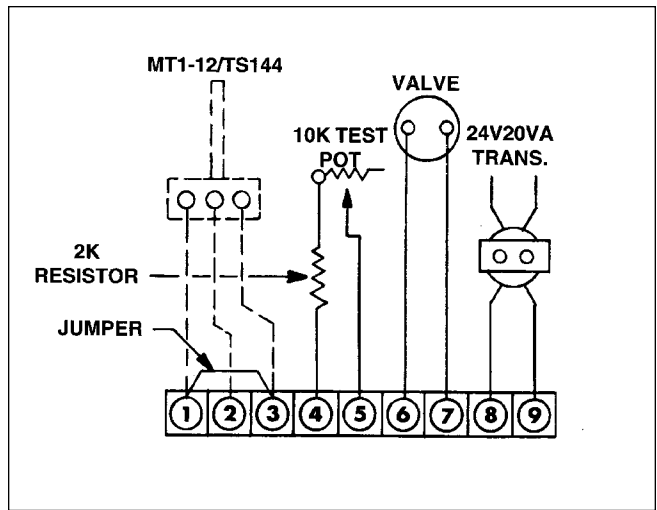
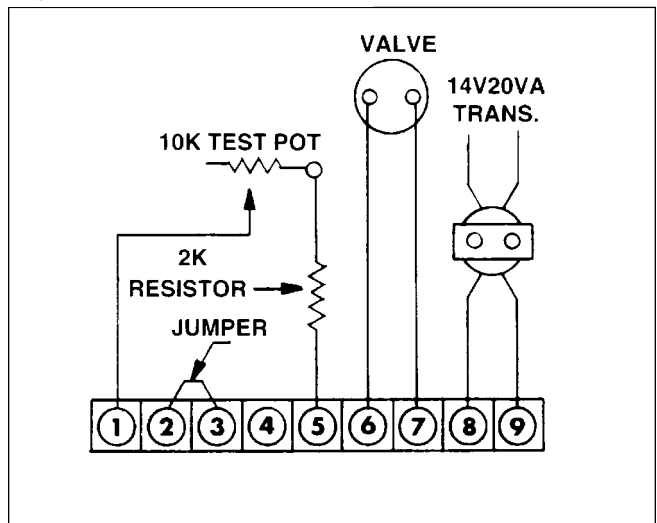

Figure 2



SECTION XI - REPLACEMENT PARTS

Replacement parts may be ordered from the factory. All warranty parts will be shipped freight allowed from the factory via standard ground service. Warranty parts must be returned prepaid within 30 days. Credit will be issued if part is complete, defective and returned on time.

When parts are ordered, MODEL NUMBER, SERIAL NUMBER, FACTORY ORDER (F.O.) AND PART NUMBERS are required. Belts, filters and fuses are not covered under warranty.

Dealer/Contractor Name: _____ Address: _____

City: _____ State: _____ Zip: _____ Ph: _____

FOR CANADIAN INSTALLATIONS ONLY

1. All installations must conform with local building codes, or, in the absence of local codes, with current CAN/CGA-B149- Installation Codes For Gas Burning Appliances and Equipment.
2. All electrical connections must be in accordance with Canadian Electrical Code, Part I, CSA Standard C22.1.

All electrical connections must conform to the current edition of the Canadian Electrical Code, Part I CSA Standard C22.1 and applicable local codes.

SECTION XII - RECIRCULATION

WARNING: On heaters, which recirculate room air, outside ventilation air must be provided in accordance with the information shown on the heater nameplate.

Recirculation of room air may be hazardous in the presence of:

- flammable solids, liquids and gases
- explosive materials such as grain dust, coal dust, gunpowder, etc.
- substances such as refrigerants or aerosols which may become toxic when exposed to heat or flame.

Recirculation is not recommended in uninsulated buildings where outside temperatures fall below 32°F (0°C).

Excessive recirculation or insufficient ventilation air, which results in inadequate dilution of combustion products generated by the heater, may create hazardous concentrations of carbon monoxide, nitrogen dioxide, and other combustion products in the heated space.

If gas fork trucks or other fossil fuel powered equipment are utilized in the conditioned area, additional ventilation requirements for the facility must be addressed separately.

The heater inlet shall be located in accordance with applicable building code provisions for ventilation air.

Field constructed intake accessories should be properly designed to minimize the entry of snow and rain. All ventilation air to the heater shall be ducted directly from the outdoors.

If in doubt regarding the application, consult the heater manufacturer.

ETL labeled heaters must be equipped with a control system and an air measuring station provided by the heater manufacturer and installed on the return air damper or duct.