

# OPERATION/INSTALLATION MANUAL WINEGARD® AUTOMATIC RV DIGITAL SATELLITE SYSTEM

## Model AS-2003 & AS-2053

U.S. PATENT NO. 5,532,710

Made in U.S.A.

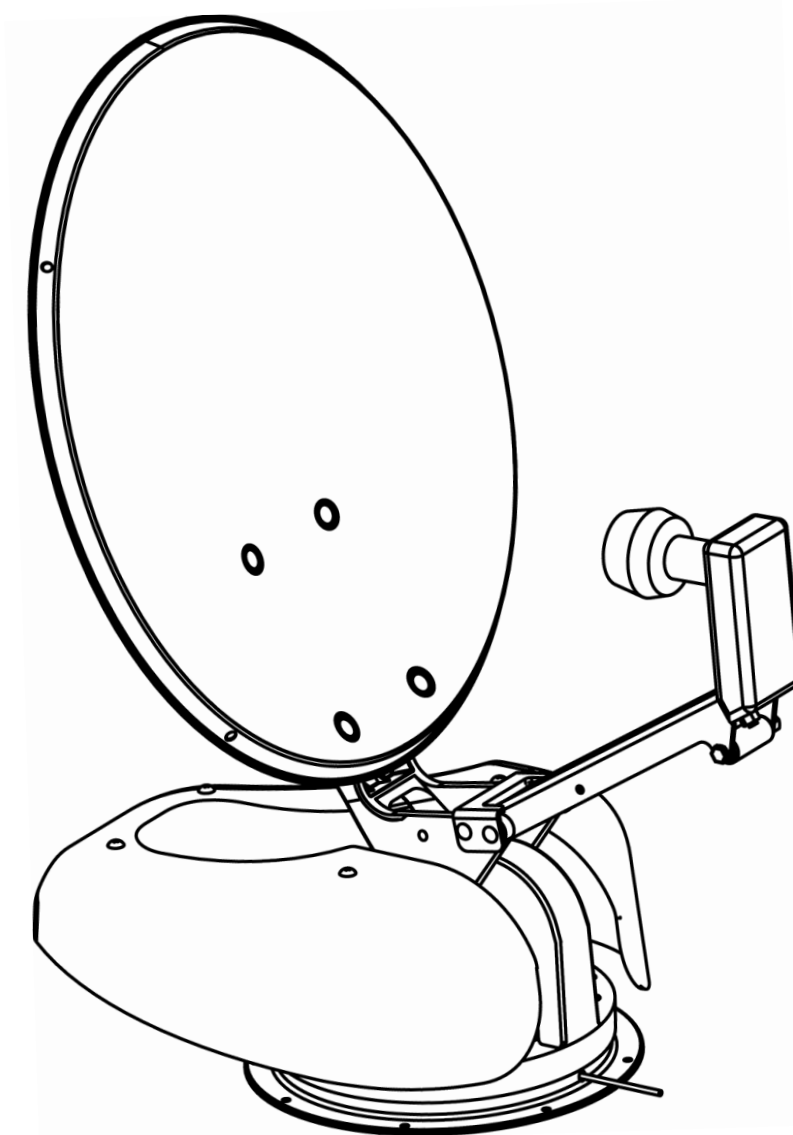

### **FOR SLOPED ROOFS:**

Use Winegard's RW-5000 roof wedge.

## IMPORTANT SAFEGUARDS

**WARNING: TO REDUCE RISK OF FIRE OR ELECTRICAL SHOCK,  
DO NOT EXPOSE TO RAIN OR MOISTURE.  
(Not applicable to mount and antenna)**

<b>CAUTION</b> <b>RISK OF ELECTRIC SHOCK</b> <b>DO NOT OPEN</b>		<b>Dangerous voltage inside enclosure</b>  <b>Refer to operating, maintenance and safeguard literature accompanying unit.</b>
<b>CAUTION: TO REDUCE RISK OF ELECTRICAL SHOCK, DO NOT REMOVE COVER, NO USER-SERVICEABLE PARTS INSIDE. REFER SERVICING TO QUALIFIED PERSONNEL</b>		

1. All the safety and operating instructions should be read before the appliance is operated.
2. The safety and operating instructions should be retained for future reference.
3. All warnings on the appliance and in the operating instructions should be adhered to.
4. All operating and use instructions should be followed.
5. Unplug this video or audio product from the wall outlet before cleaning. Do not use liquid cleaners or aerosol cleaners. Use a damp cloth for cleaning.
6. Do not use attachments not recommended by the video product manufacturer as they may cause hazards.
7. Do not use this video product near water - for example, near a bath tub, wash bowl, kitchen sink, or laundry tub, in a wet basement, or near a swimming pool, and the like.
8. If slots, holes and openings are located in the housing, they are provided for ventilation and to ensure reliable operation of the video product and to protect it from overheating. These openings should never be covered. The openings should never be blocked by placing the video product on a bed, sofa, rug, or other similar surface. This video product should never be placed near or over a radiator or heat register. This video product should not be placed in a built-in installation such as a bookcase or rack unless proper ventilation is provided or the manufacturer's instructions have been adhered to.
9. This video product should be operated only from the type of power source indicated in electrical rating printed on the appliance or power supply.
- 10A. If the appliance is equipped with a polarized alternating-current line plug (a plug having one blade wider than the other) this plug will fit into the power outlet only one way. This is a safety feature. If you are unable to insert the plug fully into the outlet, try reversing the plug. If the plug should still fail to fit, contact an electrician to replace your obsolete outlet. Do not defeat the safety purpose of the polarized plug.
- 10B. If the appliance is equipped with a 3-wire grounding-type plug, a plug having a third (grounding) pin, this plug will only fit into a grounding-type power outlet. This is a safety feature. If you are unable to insert the plug into the outlet, contact an electrician to replace your obsolete outlet. Do not defeat the purpose of the grounding-type plug.
11. Power-supply cord should be routed so that it is not likely to be walked on or pinched by items placed upon or against it, paying particular

- attention to cord at plug, convenience receptacle and the point where cord exits from the appliance.
12. If an outside antenna or cable system is connected to this video product, be sure system is grounded so as to provide some protection against voltage surges and built-up static charges. Proper method is shown below.

### EXAMPLE OF ANTENNA GROUNDING AS PER NATIONAL ELECTRICAL CODE INSTRUCTIONS

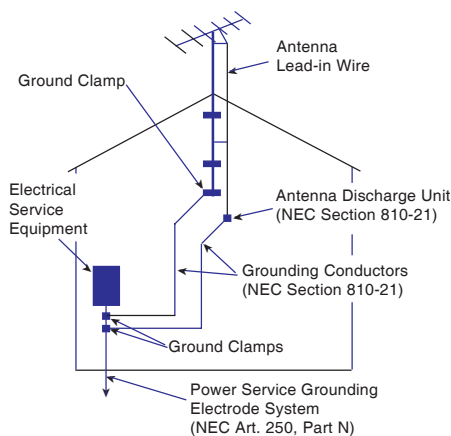

### NEC - NATIONAL ELECTRICAL CODE

13. An outside antenna system should not be located in the vicinity of overhead power lines or other electric light or power circuits, or where it can fall into such power lines or circuits. When installing an outside antenna system, extreme care should be taken to keep from touching such power lines or circuits as contact with them might be fatal.
14. For added protection for this video product during a lightning storm, or when it is left unattended and unused for long periods of time, unplug it from the wall outlet and disconnect the antenna or cable system.
15. Do not overload wall outlets and extension cords as this can result in a risk of fire or electric shock.
16. Never push objects of any kind into this video product through openings as they may touch dangerous voltage points or short-out parts that could result in a fire or electric shock. Never spill liquid of any kind on the video product.

17. Do not attempt to service this video product yourself as opening or removing covers may expose you to dangerous voltage or other hazards. Refer all servicing to qualified service personnel.
18. Unplug this video product from the wall outlet and refer servicing to qualified service personnel under the following conditions:
  - a. When the power supply cord or plug is damaged.
  - b. If liquid has been spilled or objects have fallen into the video product.
  - c. If the video product, except for antenna mounted preamplifiers and downconverters, has been exposed to rain or water.
  - d. If the video product does not operate normally by following the operating instructions. Adjust only those controls, when provided, that are covered by the operating instructions. An improper adjustment of other controls may result in damage that will often require extensive work by a qualified technician to restore the video product to its normal operation.
  - e. If the video product has been dropped or the housing has been damaged.
  - f. When the video product exhibits a distinct change in performance - this indicates a need for service.
19. When replacement parts are required, be sure the service technician has used replacement parts specified by the manufacturer or have the same characteristics as the original part. Improper substitutions may result in fire, electric shock or other hazards.
20. Upon completion of any service or repairs to this video product, ask the service technician to perform safety checks to determine that the video product is in proper operating condition.
21. Note to CATV system installer: This reminder is provided to call the CATV system installer's attention to Art. 820-40 of the NEC that provides guidelines for proper grounding and, in particular, specifies that the cable ground shall be connected to the grounding system of the building, as close to the point of cable entry as possible.
22. This product should be mounted to a wall or ceiling only as recommended by the manufacturer.
23. The product should be situated away from heat sources such as radiators, heat registers, stoves or other products (including amplifiers) that produce heat.

# Table of Contents

---

## OPERATION

Introduction .....	4
Wallplate Control Panel .....	5
Interior One or Two Receiver Connection .....	5
Automatic Operation .....	5-8
Check Switch Routine .....	8

## INSTALLATION

Tools Needed .....	3, 10
System Components, Specifications, Warranty Information .....	10
Installation Requirements .....	11
Mounting Assembly on Roof .....	12-15
Mounting Interior Wall plate Controller .....	16
Wiring .....	17

## PARTS

Antenna Parts .....	18
Base Assembly .....	19
Turret Assembly/Cover .....	20, 21
Trouble Shooting .....	22

### ***Parts included:***

18" Reflector  
Backup structure  
Mount base/turret  
Mount cover & bracket  
Vent tube  
Cable entry plate  
Hardware  
Cable  
Interior wall plate controller  
Surface mount box

### ***Tools needed for installation:***

Level  
Tape measure  
Phillips screwdriver  
Electrical tape  
Cutter  
Electric or cordless drill  
1/8" drill bit (for pilot holes)  
7/16" wrench (for dish assembly)  
5/16" socket/nut driver  
1-1/2" hole saw (for cable entry hole)  
Sealant compatible with roof material  
(check with vehicle manufacturer for compatibility)

---

## FCC PART 15 STATEMENTS

**NOTE:** This equipment has been tested and found to comply with the limits for a Class B digital device, pursuant to Part 15 of the FCC Rules. These limits are designed to provide reasonable protection against harmful interference in a residential installation. This equipment generates, uses and can radiate radio frequency energy and, if not installed and used in accordance with the instructions, may cause harmful interference to radio communication. However, there is no guarantee that interference will not occur in a particular installation. If this equipment does cause harmful interference to radio or television reception, which can be determined by turning the equipment off and on, the user is encouraged to try to correct the interference by one or more of the following measures:

- Reorient or relocate the receiving antenna.
- Increase the separation between the equipment and receiver.
- Connect the equipment into an outlet on a circuit different from that to which the receiver is connected.
- Consult the dealer or an experienced radio/TV technician for help.

**CAUTION:** Any changes or modifications to this equipment not expressly approved by Winegard Company may void the user's authority to operate this equipment.

# Introduction/How Does Digital Satellite TV Work?

## Introduction

Congratulations! You have an RV automated digital satellite reception product — AS-2003. This unit, used with your digital satellite receiver, will deliver the best reception possible. Your new Winegard digital satellite unit was designed for easy installation, setup and operation.

## How Does Digital Satellite System TV Work?

Satellite programming originates from an “uplink” facility on Earth — the facility receives many signals from different sources, combines the signals digitally and transmits to the satellites. The satellites (22,300 miles above Earth) receive the uplink signal, amplify it and then transmit it back to earth in the Ku frequency band. This signal is received by your satellite antenna whose shape reflects and concentrates the signal to the LNBF\* attached to the antenna. The LNBF is located at the “focal point” of signal reflection, that is, the point at which the maximum amount of signal is effectively concentrated. The LNBF amplifies and converts the signal to the 950 to 1450 MHz range. The signal is then passed through a coaxial cable to the electronics box, then to the receiver where individual channel selection and processing take place.

\* Low Noise Block Converter Feed

For Programming information call:  
**DISH NETWORK™ - 1-800-333-DISH (1-800-333-3474)**  
**DIRECTV® - 1-800-DIRECTV (1-800-347-3288)**  
**ExpressVu - 1-888-SKYDISH (1-888-759-3474)**

*Your new Winegard RV Digital Satellite Unit is an easy-to-install, easy-to-use satellite TV reception system. Because it mounts on the top of your recreational vehicle, it goes where you go and provides quality reception of digital satellite signal in the continental United States only. Check with your programming provider for exact coverage area.*

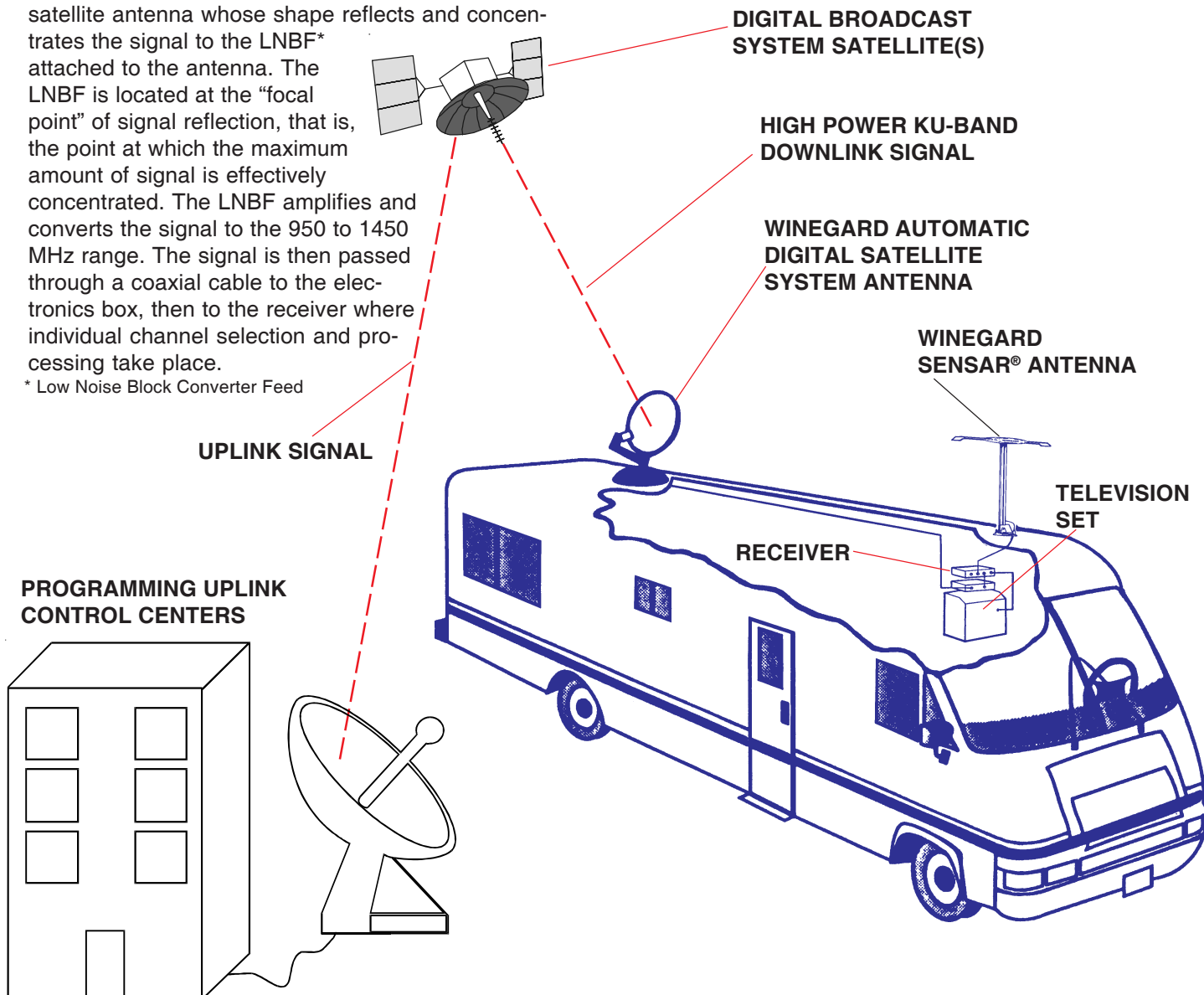

# Wall plate control panel description, wiring hookup diagrams

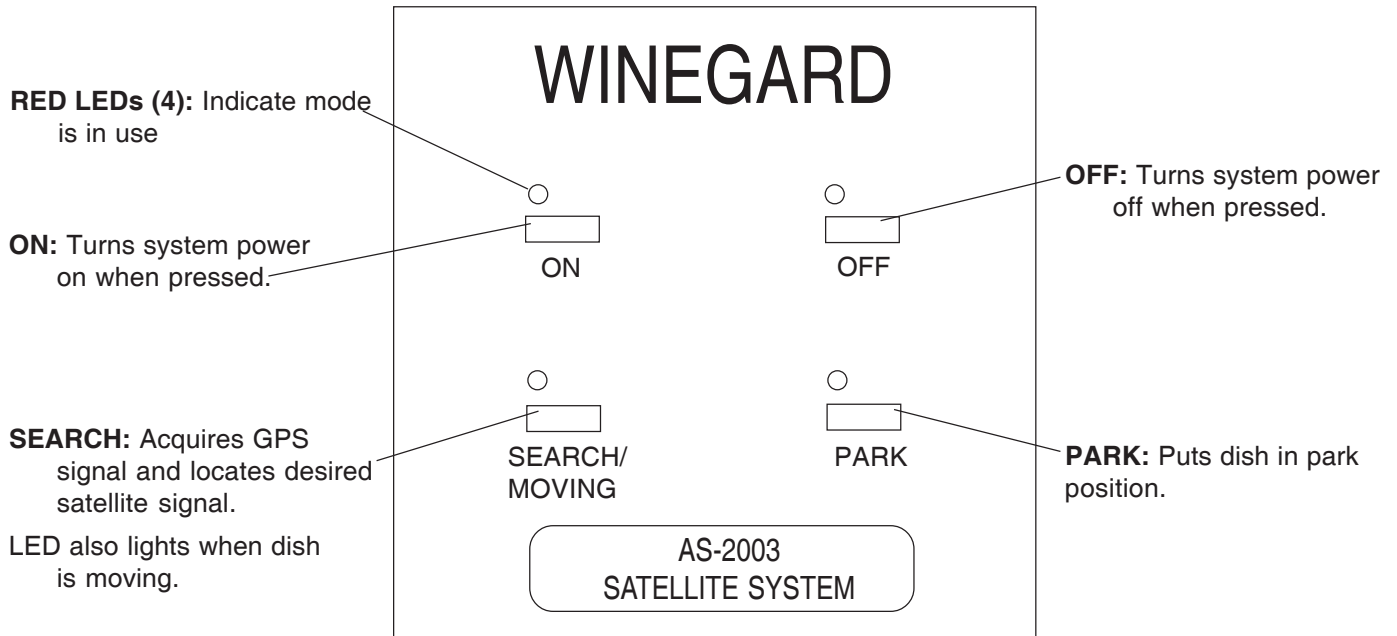

## Interior connections for one and two receivers

### ONE RECEIVER HOOKUP

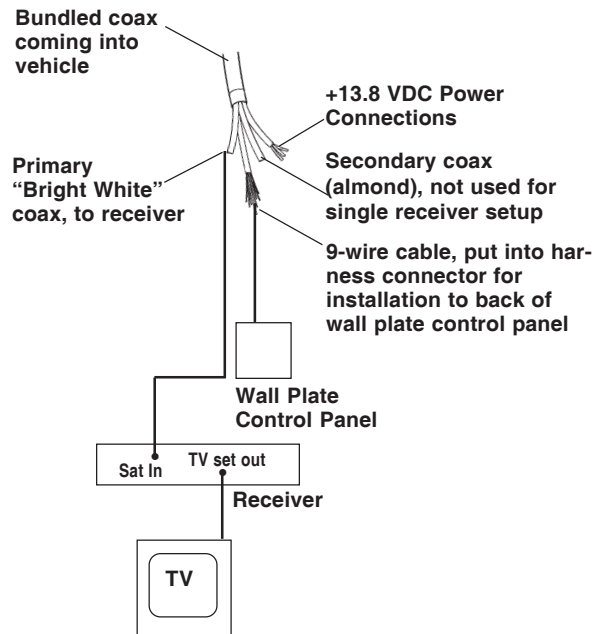

### TWO RECEIVER HOOKUP

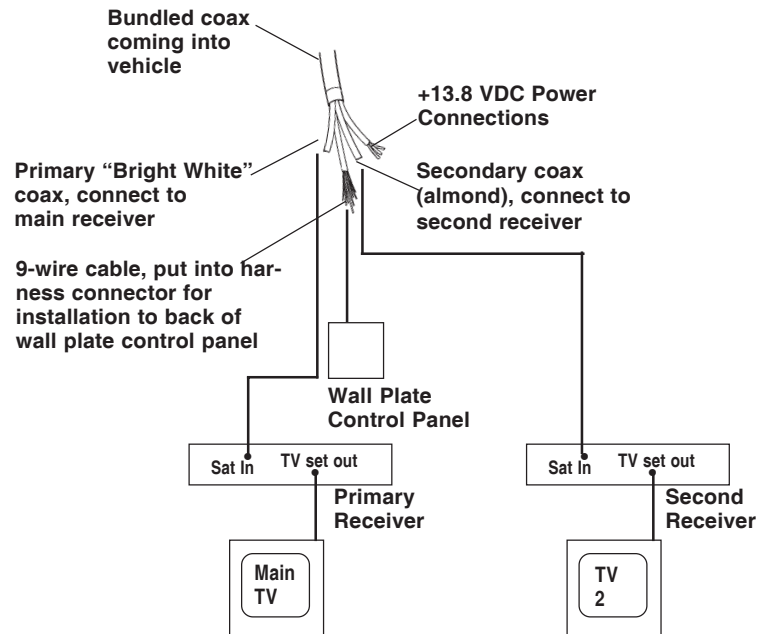

# System Operation

**BEFORE parking and leveling vehicle**, look for trees, buildings, hills or mountains that might block the satellite signal and result in poor signal reception.

## **ABOUT YOUR RECEIVER (The unit is factory preset to find 119°W (DISH Network):**

If you have a DISH Network™ receiver, be sure your unit (AS-2003) is set to receive DISH Network satellites. If you have a DIRECTV® receiver, be sure your unit (AS-2003) is set to receive DIRECTV satellites. (The majority of programming for DISH Network is on satellite 119°W; for DIRECTV, it is on 101°W.)

**AS-2003 is factory preset to find 119°W (DISH Network).** You can contact **DISH Network** at **1-800-333-DISH (1-800-333-3474)** for programming information.

Contact **DIRECTV** at **1-800-DIRECTV (1-800-347-3288)**, or **ExpressVu** (Canada and Northeast U.S.) at **1-888-SKY-DISH (1-888-759-3474)**.

**IMPORTANT!** If you are using more than one receiver, the primary (the “bright white” coax connection) is the only receiver that will toggle between satellites.

## **FIRST TIME USE:**

**The unit is factory preset to find 119°W (DISH Network).** For DIRECTV, you must change the preset switches on the outside unit. **See Step 8 in Installation, page 14.** The first time your unit is used, allow 10 minutes for GPS acquisition. (This is also true if you have stored your unit for six months or longer. **This is typical of first time use;** do not think there is a malfunction.

1. Turn TV on and tune to channel 3 or 4 (the output of your receiver).
2. Turn on your primary receiver. **The receiver MUST BE TURNED ON and LNBF COAX PROPERLY ATTACHED** (refer to your receiver owner manual). If not properly connected, all LEDs will be on.
3. To search for satellite, see Power On and Satellite Search procedures, AS-2003 Control Panel Operation instructions, page 7.
4. After search routine is completed and primary receiver is at 119 (DISH Network), the unit may switch between the primary and alternate satellite. A **Check Switch** must be performed for toggling capabilities on DISH Network. **See Check Switch instructions, page 8.**
5. After the primary satellite signal is found and Check Switch completed, the unit may be powered off. To switch satellites, turn power back on and switch satellites. The unit can then be turned off. The satellite signal last selected will still be “seen” by the dish when the unit is turned on again.
6. To park your unit, see Parking procedures, AS-2003 Control Panel Operation instructions, on page 7.

## Wall Plate Control Panel

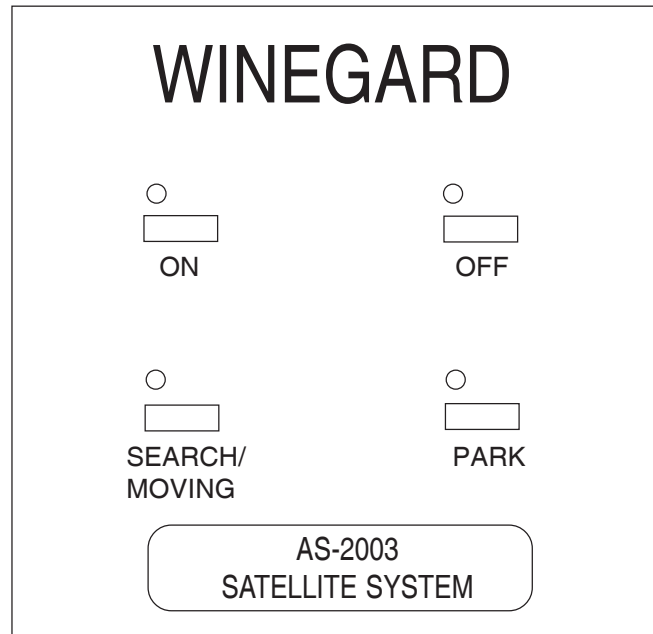

### **LED ERROR CODES**

Errors are indicated by LEDs.

OFF AND SEARCH LEDs are on.

Satellite signal search failure.

ON, PARK, SEARCH, OFF LEDs are on.

Indicates receiver is not plugged into active 110 VAC, malfunction of receiver, bad LNBF or bad coax connection.

ON, OFF LEDs are on.

Indicates a problem with the unit motor.

**POWER MUST BE TURNED OFF AND BACK ON TO CLEAR ERROR LIGHTS.**

# Control Panel Operation

Unit is off. All four LEDs are off.

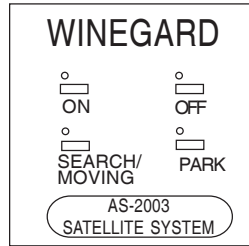

## POWER ON

1. Press the ON button on the control panel. All four LEDs will flash and the ON LED will remain on.
2. After approximately 5 seconds, all four LEDs will flash while the unit is checking for proper signal level. If all four LEDs remain on, refer to the WALL PLATE ERROR CODES, page 22.
3. After the signal is checked, the ON LED and PARK LED will remain on if the unit was last in park position.

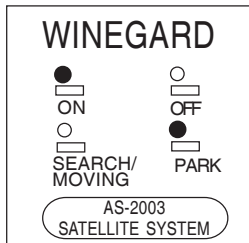
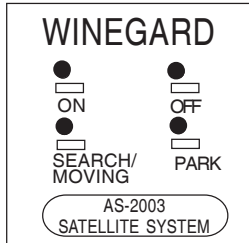
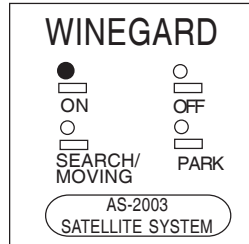

**OR**

The ON LED will remain on if the unit was last in an upright position.

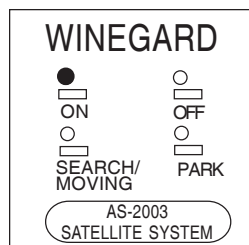

## SATELLITE SEARCH

1. Press the SEARCH button one (1) time. The SEARCH LED will come on and all other LEDs will go off. This indicates the unit is in search mode and waiting for GPS acquisition. GPS acquisition time will range from immediate to several minutes. (**Important:** Press the search button only once. Pressing the SEARCH or PARK buttons in this mode will turn the SEARCH LED off and the ON LED back on, aborting the previous search. To restart, go to the beginning of SATELLITE SEARCH procedure.

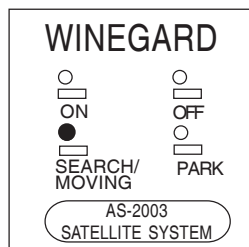

2. After successful GPS acquisition, the ON LED will come back on and the SEARCH LED will remain on, indicating the unit is now moving in the search routine and actively seeking the desired satellites. When *ON and SEARCH LEDs are on at the same time, the unit is moving and searching.* The search routine can be stopped at any time by pressing the SEARCH button or the PARK button; However, doing so will return a SEARCH Error, turning the ON LED off and the SEARCH and OFF LEDs on. The search can be restarted by going to the beginning of SATELLITE SEARCH procedure. The OFF button may also be pressed to stop the search routine. The unit can be restarted using SATELLITE SEARCH procedure.

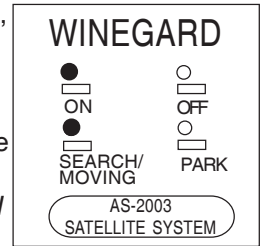

3. When the unit is finished searching and has stopped moving, the SEARCH LED will go off automatically, leaving only the ON LED still on. This indicates the unit has completed a successful search. It will take approximately 4 to 5 minutes to complete a search routine after GPS acquisition. If the unit has stopped and any other LEDs (besides the ON LED) are on, refer to the WALL PLATE ERROR CODES on page 22. (**NOTE:** If an error message shows on the TV screen during initial search, the signal has been lost. This is normal and means the dish has temporarily lost the signal but is still searching (peaking).) **Do not try to stop system!**

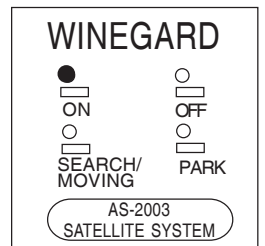

## PARKING

1. If the unit is still powered on, only the ON LED will be on. **Press the PARK button two times (2)** to park the unit. The SEARCH and PARK LEDs will also come on, indicating the unit is moving to the park position. (**Important:** If the unit has been turned off and on at any time or the unit has been stopped using the SEARCH or PARK button, it is only necessary to **press the PARK button one time (1)**, to park the unit.) *Any-time the ON, PARK and SEARCH LEDs are on at the same time, the unit is moving to the park position.* The park routine may be stopped anytime by pressing the SEARCH button or the PARK button. Pressing either button will turn off the SEARCH and PARK LEDs, leaving the ON LED still on. The park routine can be restarted by pressing the PARK button one time (1). The OFF button may also be used to stop the park routine. The unit may be restarted going to POWER ON procedure.

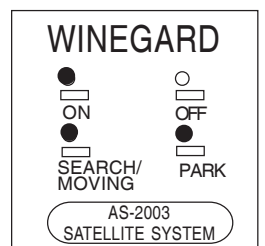

# Control Panel Operation/Check Switch Routine

- When the unit has finished the park routine, the SEARCH LED will automatically go off, leaving only the ON and PARK LEDs still on. This indicates the unit is properly parked and can be turned off. Before traveling, be sure the unit is in parked position. To be sure, step outside and visually inspect before leaving your location.

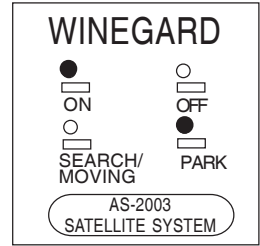

**NOTE:** If the unit is raised and you want to put in park position, the **satellite receiver must be on** and supplying voltage to the LNBF.

## Performing Check Switch routine to enable satellite toggle function used with multi-satellite programming

AS-2003 will toggle between different satellites for the program provider you have. Both DIRECTV and DISH Network have programming on more than one satellite.

When a channel is selected on the remote control and it is not located on the satellite the unit is currently on, the system on the vehicle will automatically move to the new satellite. (When using multiple receivers, toggling is controlled by the primary receiver. The primary receiver is connected to the dish with the white coax; secondary receiver if used, connects with the almond coax).

### DIRECTV programming

- There is some SETUP required for DIRECTV. You must select **“Oval Dish 2 Satellites”** in the receiver menu. To change this, see Owner’s Manual for DIRECTV receiver. When you request a channel located on a different satellite, the unit will automatically move to that satellite.

### DISH Network programming (DISH 500)

**NOTE: Once these steps have been completed, you will not need to perform this test again, unless check switch was performed on another satellite dish such as a home dish.**

- Wait for unit to acquire the satellite signal on satellite 119. (See search procedure, pp. 6-7.)
- After signal has been acquired, 6 minutes remain to complete Check Switch test; this 6 minutes will expire with unit on or off. Consult DISH Network receiver manual to perform Check Switch test.
- During the Check Switch Test, the receiver will begin checking your switch by toggling between transponders. When this is completed, SW42 will appear on the screen. It will be at the top of the screen, satellite designations will be below, showing odd and even transponders. See illustration below.

**NOTE: If a switch other than SW42 appears, or you have an X in one the of the boxes below the satellites, repeat Check Switch steps.**

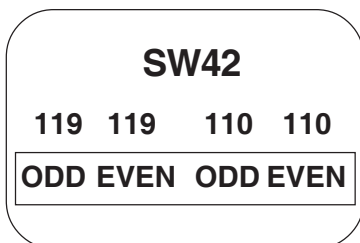

Check Switch screen display

- If you still have an error, your vehicle may be parked so satellites are on either side of the automatic stop on the roof unit. The dish is unable to locate the second satellite because it is forced to complete almost a full revolution because of the stop. (See illustration.) You can go outside and watch the dish to see if this is happening.

The solution is to move your vehicle to a different angle so the satellites are not located on either side of the stop in the outside unit.

- Your system is now set up to toggle between satellites. It will automatically move to the correct satellite when channel is selected.

Stop interrupts Check Switch operation

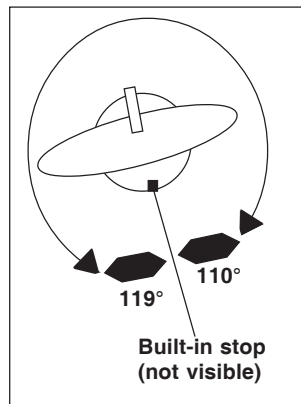

Stop does not interrupt Check Switch operation.

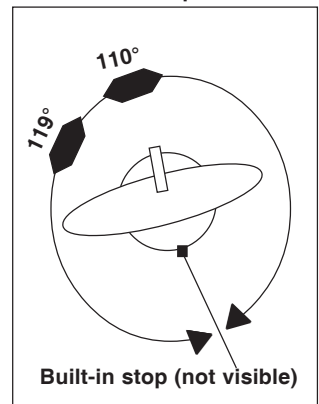



# **INSTALLATION**

## **Model AS-2003 & AS-2053**

# Parts/Specifications/Warranty

## Parts included

18 "Reflector  
Backup structure  
Mount base/turret  
Mount cover & bracket  
Vent tube  
Cable entry plate  
Hardware  
Cable  
Interior wall plate control  
Surface mount box

## Tools needed for installation

Level  
Tape measure  
Electrical tape  
Cutter  
Phillips screwdriver  
Electric or cordless drill  
1/8" drill bit (for pilot holes)  
7/16" wrench (for dish assembly)  
5/16" socket/nut driver  
1-1/2" hole saw (cable entry hole)  
Sealant compatible with roof material (check with your vehicle manufacturer for compatibility)

## Dish Specifications

Reflector Diameter ..... 46 cm (18")  
Antenna height ..... 53 cm  
Antenna width ..... 49 cm  
Gain at mid-range  
    11.2 GHz ..... 33.22 dBi  
    12.1 GHz ..... 33.89 dBi  
    12.6 GHz ..... 34.23 dBi  
Effective aperture ..... 46 cm  
Aperture efficiency ..... 73%  
Cross polarization (on axis)..... -21 dB  
Beamwidth at -3 dB ..... 3.5°  
Beamwidth at -10 dB ..... 7.0°  
F/D Ratio ..... 0.59  
Frequency Range ..... 10.95-12.75GHz  
Offset angle ..... 24°  
Gauge ..... 22 gauge galvanized steel  
Finish: ..... Textured thermoset powder coat

## Electronics Specifications

Primary Power ..... +13.8 VDC  
Power Consumption ..... 3 amps  
Operating Temperature ..... -10° to +130°F  
Humidity ..... 90% noncondensing  
Size ..... 4-1/2"W x 4-1/4"H x 1-3/4"D  
Weight ..... 1 lb.

## Mount Specifications

Height Lowered ..... 8"  
Height Raised ..... 30" vertical max.  
Roof space required ..... 40"L x 20"W min.  
Turning diameter clearance ..... 33"  
Antenna Movement ..... 2 DC motors  
Weight ..... 16 lbs.  
Shipping Weight ..... 20 lbs.  
Carton ..... 27-3/4"L x 20-3/8"W x 10-3/4"D

# Installation requirements

To install the Winegard Automatic Digital Satellite Dish, check with your RV dealer or manufacturer. Your RV may already be pre-wired for this system, and/or may have a re-inforced roof area available.

1. Choose a location on the roof that will allow the dish to raise and rotate without interference from other roof-mounted equipment.
2. **Roof space required for operation is 40”L x 20”W minimum.** Refer to Figures 1, 2, 3 and 5 for operating parameters.
3. The unit must be level for best operation. The unit may be up to 2.5° off level. For the fastest, most reliable operation, it should be as close to level as possible. Use the hydraulic or manual leveling equipment on your vehicle to level the roof as much as possible. **Before beginning installation:** If the mounting area is not level, you can use a roof wedge, Figure 4. Winegard’s RW-5000 roof wedge corrects tilt up to 3.7°. For units with severely sloping roofs, more than one wedge may be needed. If the roof wedge is too thick, use stainless or aluminum washers.
4. When choosing a location for the interior wall plate control panel, consider wiring, ease of viewing wall plate and distance from your television set.

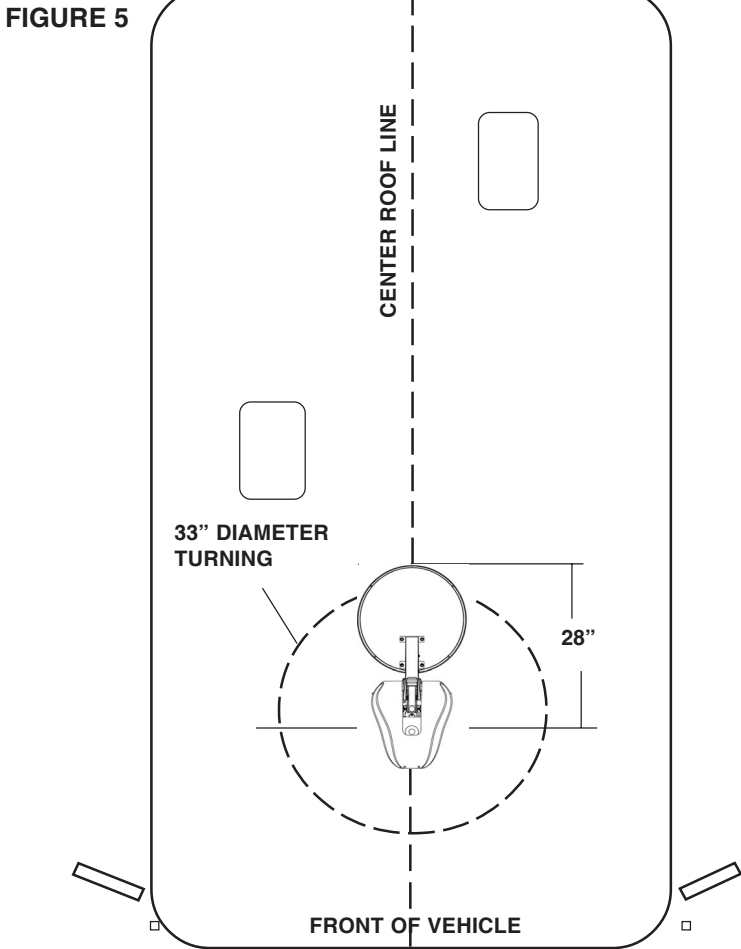
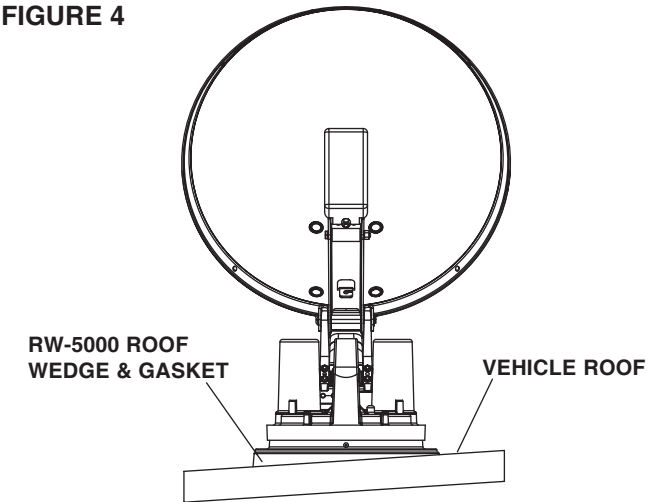
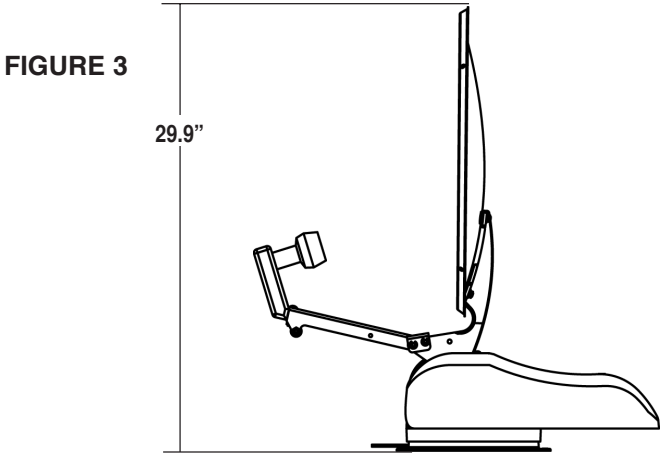
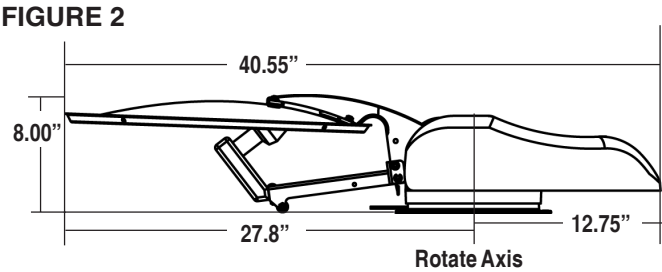
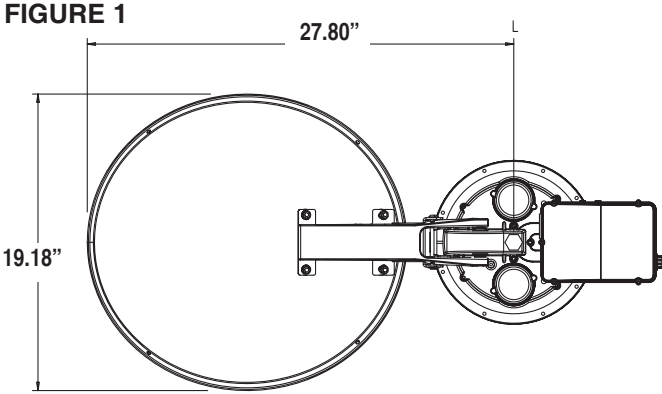

FIGURE 6

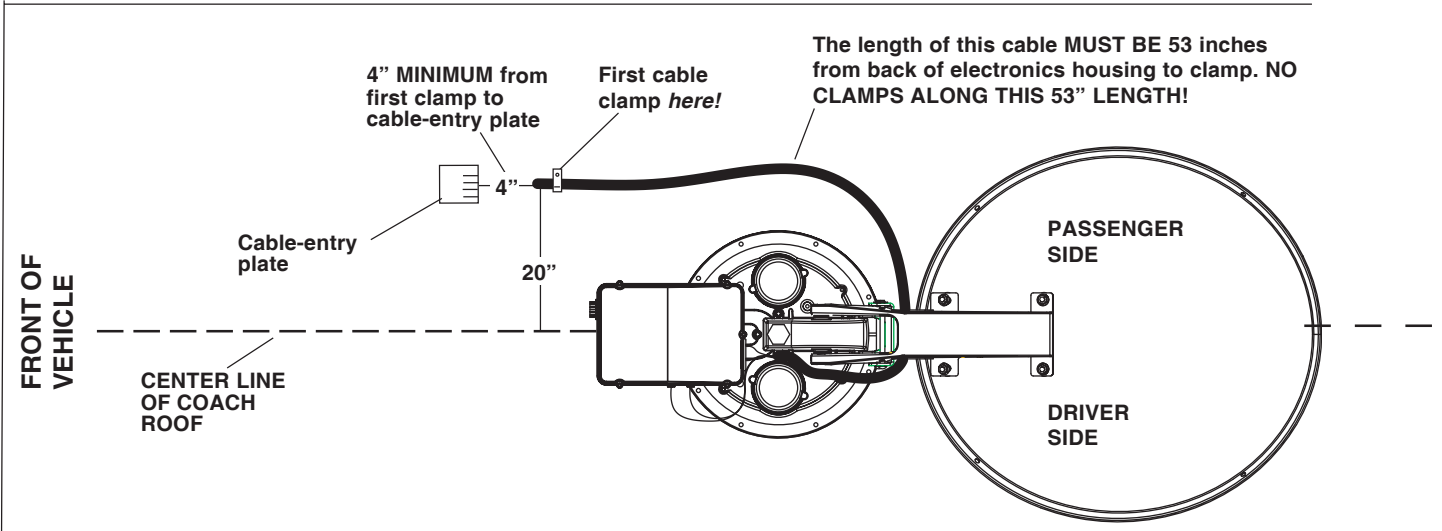

FIGURE 6A

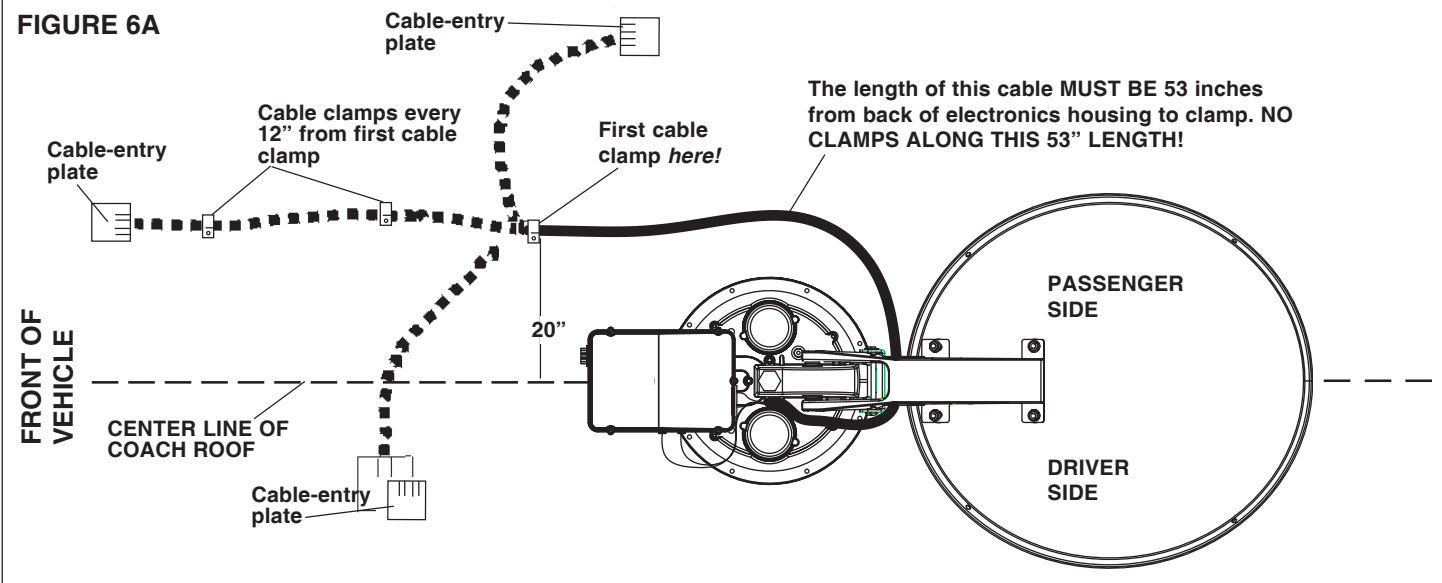
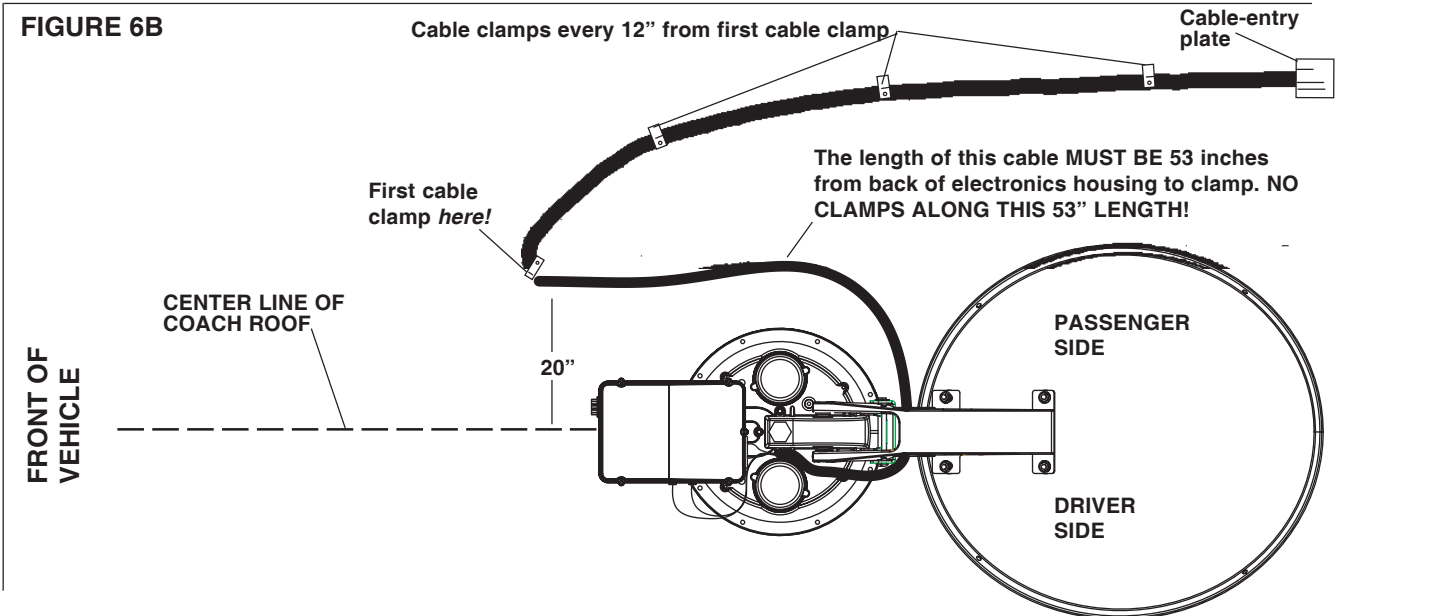

FIGURE 6B



# Roof installation

1. Position the roof template on the vehicle roof and drill 1/8" holes for the screws. **DO NOT drill clear through into interior of vehicle.** The screws fasten mount to the roof only. Be sure the roof can securely hold system.
2. Place base plate gasket under the base before screwing unit down. Secure the base plate of the motorized assembly to the roof using appropriate screws. **DO NOT APPLY SEALANT AT THIS TIME.**  
**Note: IF YOU ARE USING THE ROOF WEDGE (RW-5000), use the 3/16" gasket included with motorized mount under the roof wedge.** Install 1/16" gasket included with the RW-5000 roof wedge *between mount and roof wedge.* Longer screws are needed for installation when using roof wedge.
4. Partially unroll your bundled cable and gently remove any kinks.

**CAUTION!! See illustrations on page 12. Cable MUST BE ROUTED AS SHOWN IN FIGURE 6, 6A, and 6B to prevent cable wrap! If not routed correctly, you may STRIP GEARS!**

5. Route cable assembly around the base of the unit, Figure 6. **FROM THE BACK OF THE ELECTRONICS BOX TO THE FIRST CLAMP MUST BE 53"!**
6. Drill hole for cable entry in appropriate place. **THIS MUST BE 4" MINIMUM FROM FIRST CLAMP!** You can also run cable to an *existing* cable entry hole that meets the *same distance requirements (4" minimum)*, Figure 6A. Be sure cable from mount to entry point is not too tight when dish is in stow position. If there is not enough slack in the cable, it will bind and prevent proper operation, or damage the mount.
7. Cut the cable wrap approximately four (4) inches away from point where it enters the cable-entry plate, Figure 7. This allows proper sealant coverage. Do not damage cables when cutting away the cable wrap. (The cable wrap protects and keeps together in one unit the coaxial cable, electrical cable and 9-wire control cable.) After cutting, wrap the outer cable wrap with electrical tape as shown, Figure 7. Push cable through cable entry point on roof. Do not damage cable. **DO NOT APPLY SEALANT AT THIS TIME.**
8. Place cables in rounded slots on cable entry plate. Fasten down plate with screws provided. **DO NOT APPLY SEALANT AT THIS TIME.**

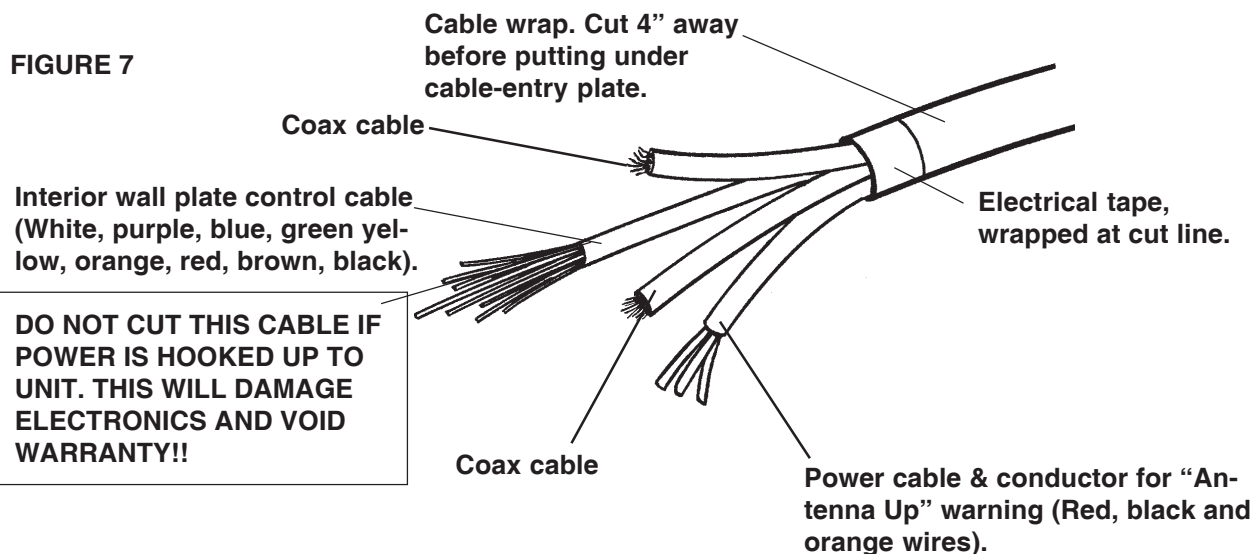

## NOTE:

The "bright white" coax cable is the primary coax that will be connected to your main receiver. The other coax cable is the secondary coax for a second TV and receiver. See page 5, Operation section, for examples of one and two receiver setups.

# EXTERNAL GPS INSTALLATION

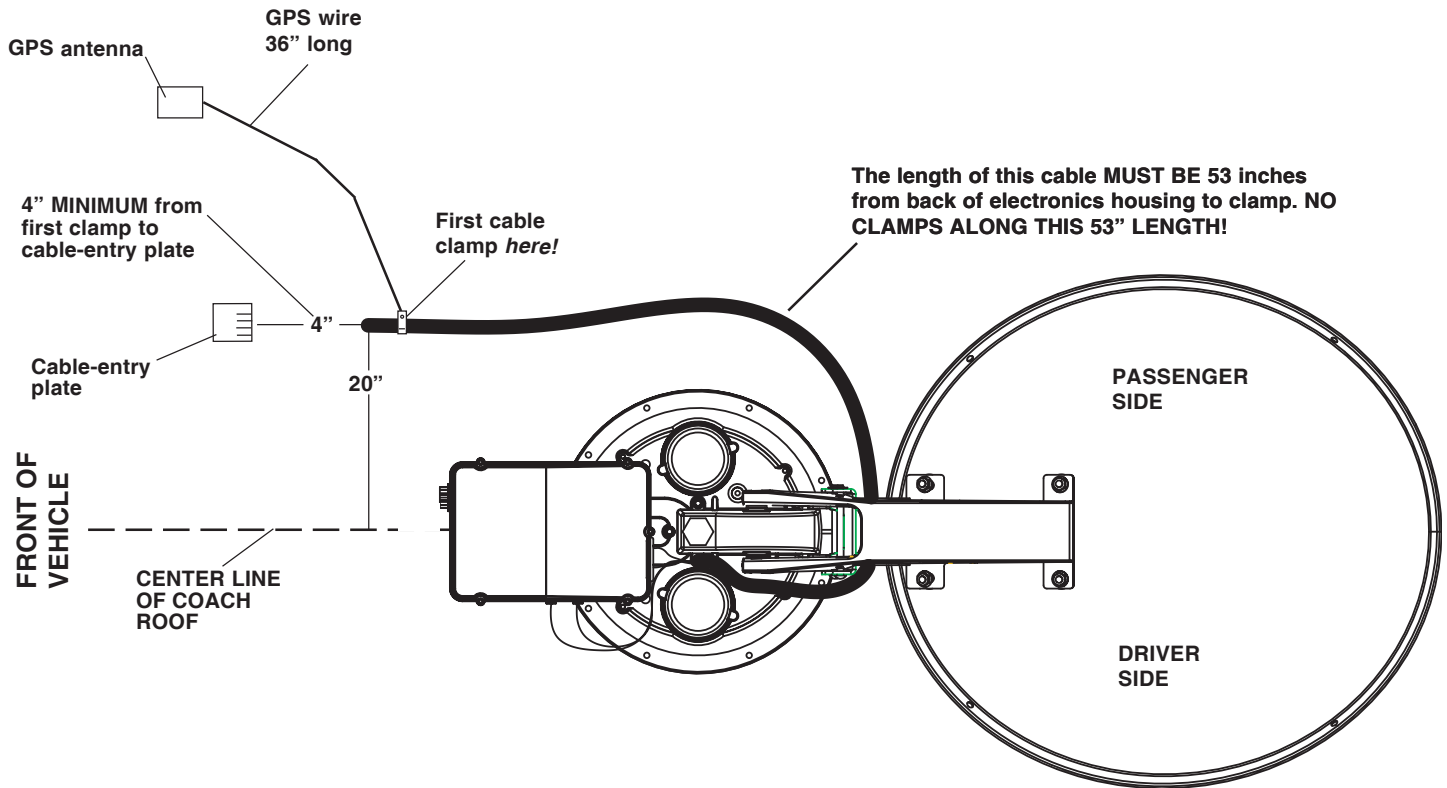

## BEFORE BEGINNING INSTALLATION, REFER TO DRAWING

9. GPS antenna can be installed within 3' of the first cable clamp. It must have a clear view of the sky to operate properly, and should have a level location.
10. Install away from air conditioners, satellite antenna and mount, or any other roof-mounted equipment.
11. Decide where your GPS antenna will be located. Clean roof area with an approved cleaner for your roof material.
12. After placing the GPS in the desired location, do not secure. Test your system before securing permanently.
13. To permanently secure the GPS antenna, carefully peel the backing off the tape on the bottom of the unit, then press down on the roof.
14. To prevent movement of the GPS wire, secure with an approved sealant every 6".

14. Install the vent tube on the back of the mount base (This is the side opposite the word FRONT). The hole for the vent tube is shown in Figure 8. **CAUTION: DO NOT seal the hole in vent tube.** Put sealant around the outside of the vent tube, approximately 1/2 inch from end. Push the vent tube into the vent tube hole, Figure 8. The sealant will seal the hole as you push in. Leave approximately 2 to 2-1/2 inches of the vent tube extending from the hole. **DO NOT APPLY SEALANT TO ANY SURFACES UNTIL YOU TEST YOUR UNIT.**

FIGURE 8

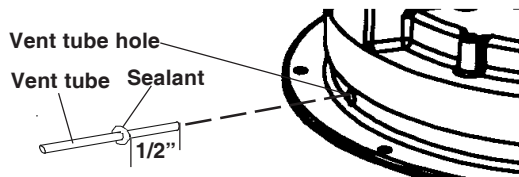

15. **BEFORE YOU INSTALL THE BASE COVER,** you must **SET THE SWITCHES** in the outside unit. Decide which programming you will be using. This will determine how you set your switches. To set the switches for the satellite used by your programming provider, remove the small plate on the side of the electronics box, Figure 9. You will need a Phillips screwdriver.

FIGURE 9

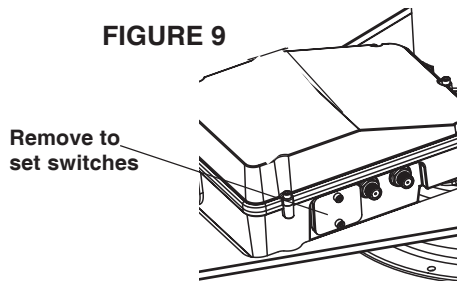

The switches will appear upside down, numbers will be counter-clockwise. *Set numbers right to left.*

For **DISH Network®** set to **119°**



For **DIRECTV®** set switches to **101°**

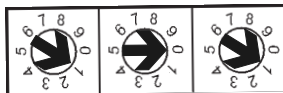

For **ExpressVu®** set switches to **092°**

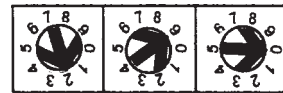

16. After setting the switches, replace the small plate shown in Figure 9. Be sure to tighten securely; the insulating material on the inside surface provides weather protection.

17. Install the base cover, Figure 10.
- Place cover on unit.
  - Line up holes in cover to holes in motor housing and electrical box. Use **COARSE THREAD SCREWS** to attach to **MOTOR HOUSING**. Use **FINE THREAD SCREWS** for **ELECTRICAL BOX**.

FIGURE 10

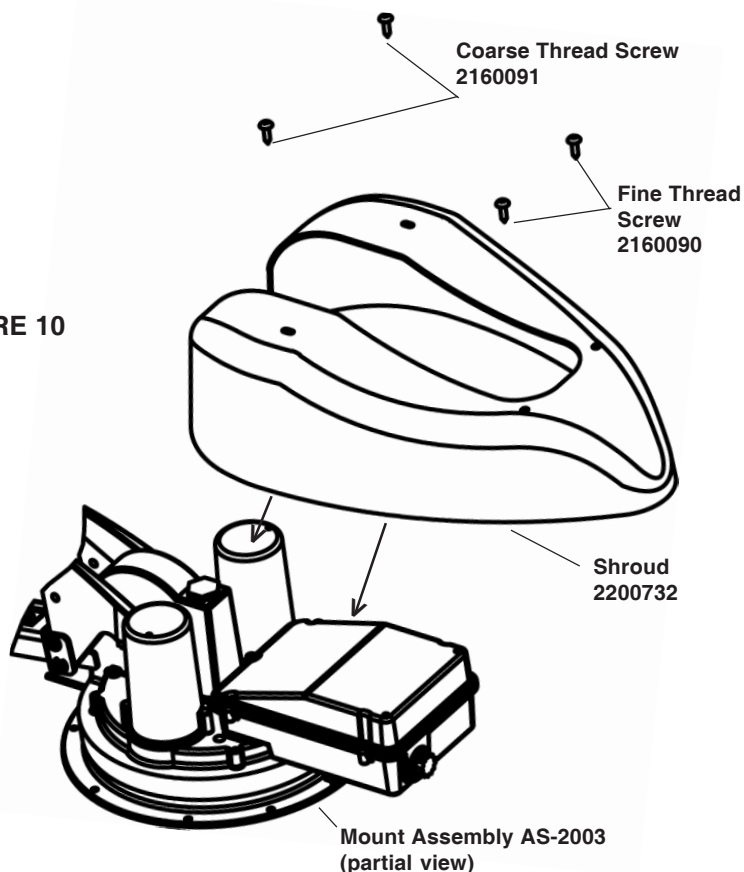

**TEST UNIT TO BE SURE IT OPERATES PROPERLY *BEFORE* YOU APPLY ANY SEALANT!**  
Use a sealant compatible with your roof material.

# Mounting interior wall plate controller

Inside your vehicle, choose a convenient location for the wall plate controller. Consider wiring layout and distance from your television set. The wall plate uses the nine-wire multicolored cable.

1. Strip end of each wire. Place in harness in the locations indicated in Figure 11. Be sure there are no individual “strays” from the wires that are not in the slot. These “strays” can interfere with operation.
2. After putting each wire in the appropriate slot, tighten the screw.
3. When all wires are in place in the harness end, plug this into the back of your wall plate control panel, as shown in Figure 11. **DO NOT** plug in upside down or incorrectly; your unit will not operate, or you may cause irreparable damage. Note label on board to help with positioning of plug.

FIGURE 11

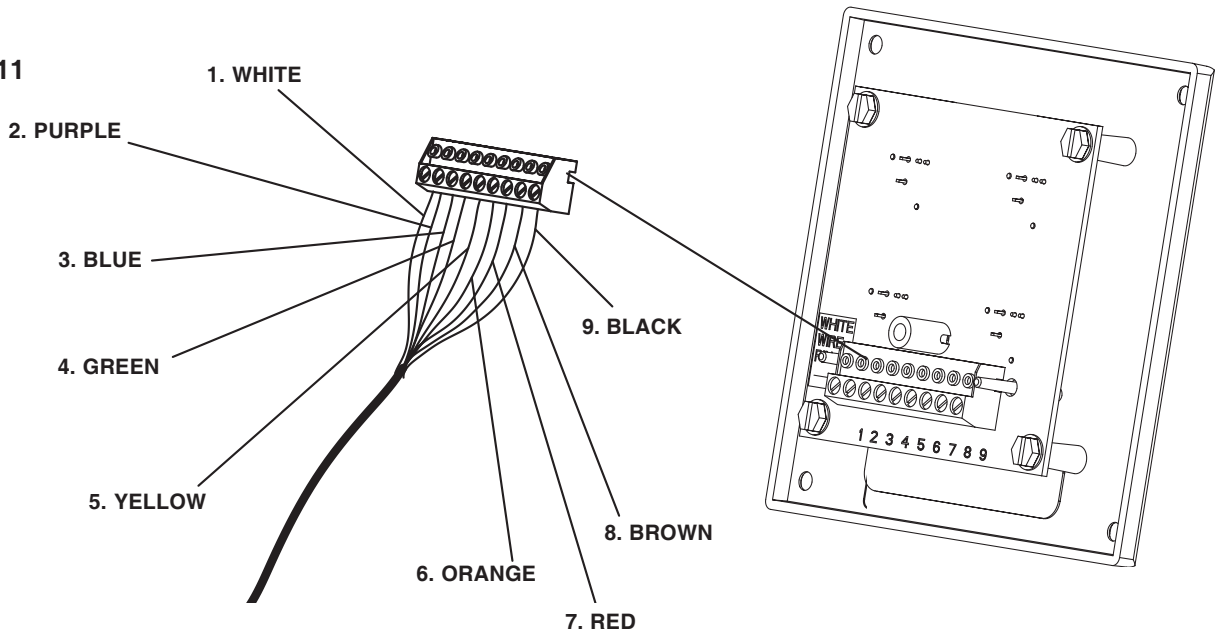

4. Mount the wall plate controller flush with the wall or inside a cabinet. Push the wire harness through the hole, connect to the wall plate and secure screws.

You can also use the surface mount box (provided), Figure 12.

When using mount box, you may have to knock out the portion of the box indicated by the dotted line in Figure 12.

**Surface Mount  
Box for Wall  
Plate Controller**

**Box can be  
mounted two  
ways, as shown.**

FIGURE 12

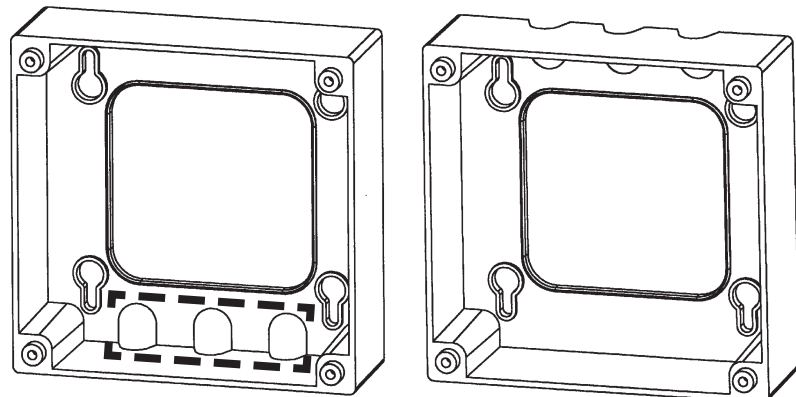



### Wiring the system:

This unit requires a +13.8 VDC fused circuit. Unit draws up to 3 amps. The unit uses sophisticated micro-processor technology and needs “clean” (filtered) power to function properly.

**DO NOT USE power designated to operate a +12 VDC lighting circuit from the converter, or a converter that does not have a battery connected to it, or any unfiltered converter! Damage to the system could result!**

If in doubt, contact your dealer or the manufacturer of your vehicle.

**NOTE: See page 5, Operation section, of this manual for one and two receiver set-ups.**

1. Make connection of the RED WIRE to +13.8 VDC (constant supply of power).  
**DO NOT HOOK UP ORANGE WIRE.** This is for “Antenna Up” warning sensor supplied by most RV manufacturer. **DO NOT CONNECT ORANGE WIRE TO +13.8 VDC!**  
Connect the BLACK WIRE to the ground.
2. Connect the “BRIGHT WHITE” (PRIMARY) COAX CABLE to “Satellite In” jack on the back of your receiver. The primary coax must be hooked to the electronics box. This receiver controls the toggle function.
3. Connect the receiver “Out to TV” to the television.
4. Plug receiver into 117 VAC receptacle.
5. Connect the other cable to your second receiver/TV.

### For proper operation:

1. To check for LNBF voltage, you must have your receiver connected to your system. Lack of receiver or a bad connection at some point will result in the dish not being able to lock on any satellite signal. All LEDs on wall plate control panel will be on until corrected.
2. Refer to the Operation Section to fully test the system!

### Check Switch function and toggling between satellites

For a complete description of these functions, see Operation section.

# Antenna

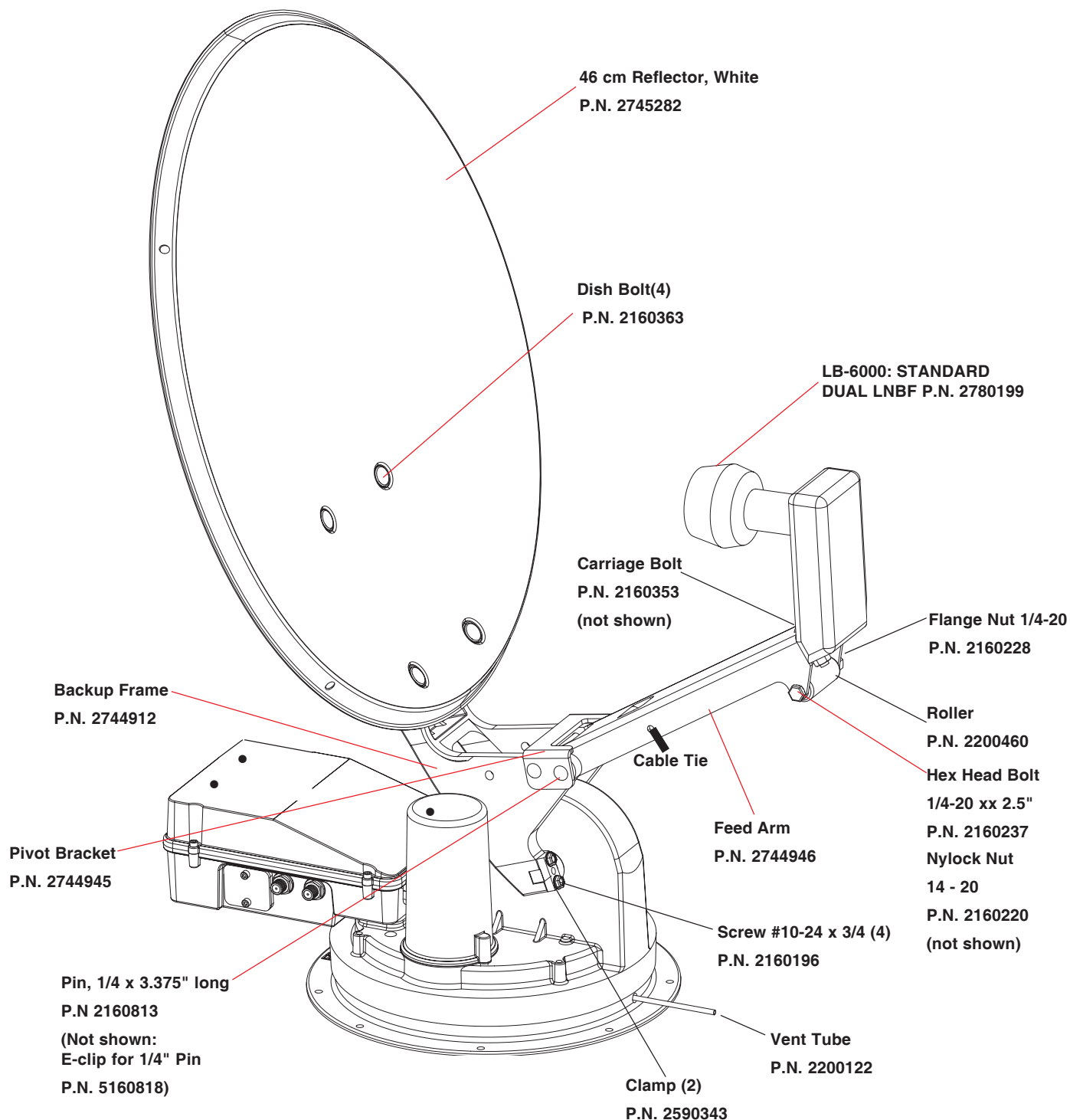

# Base Assembly

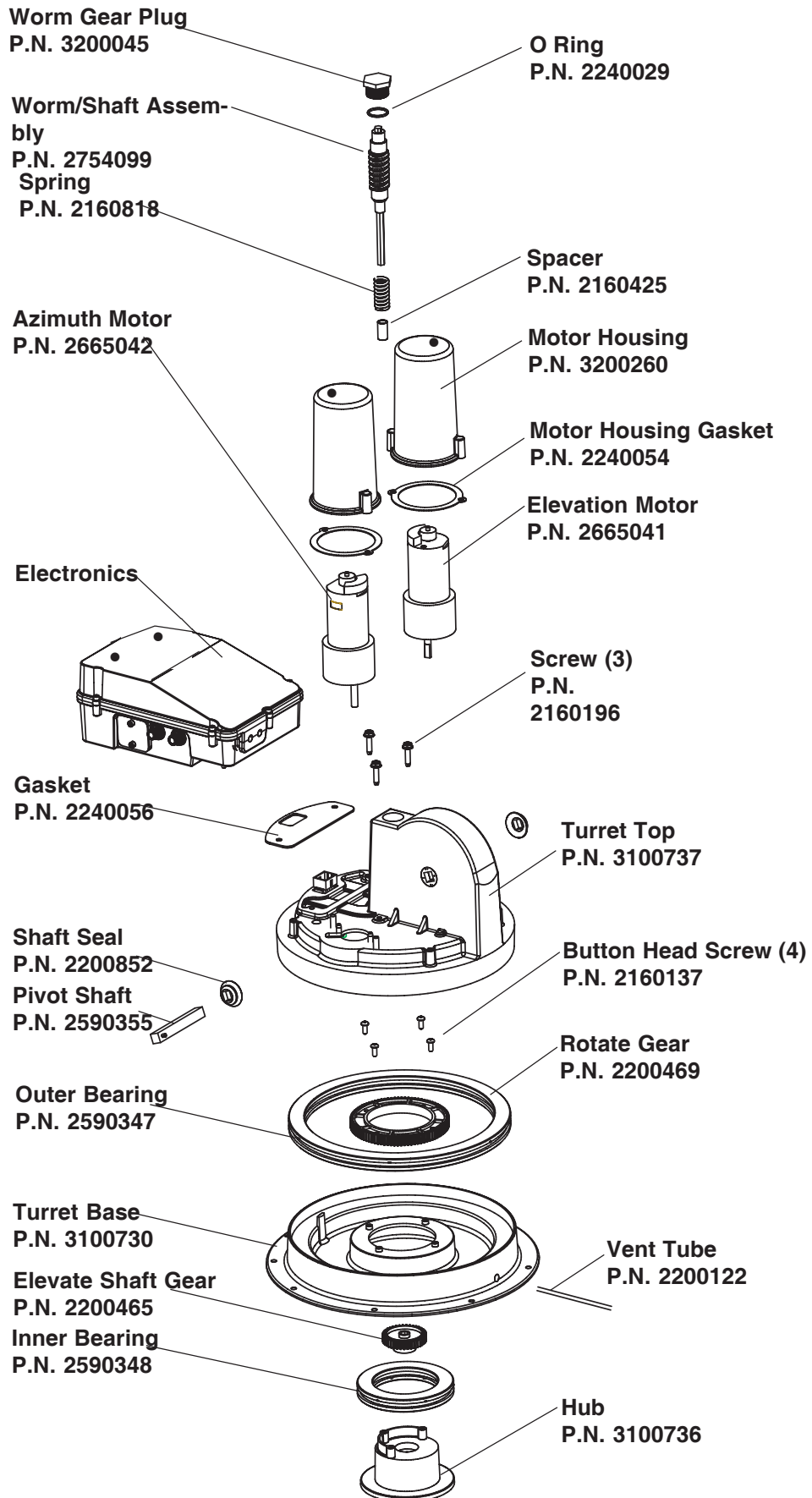

# Turret Assembly

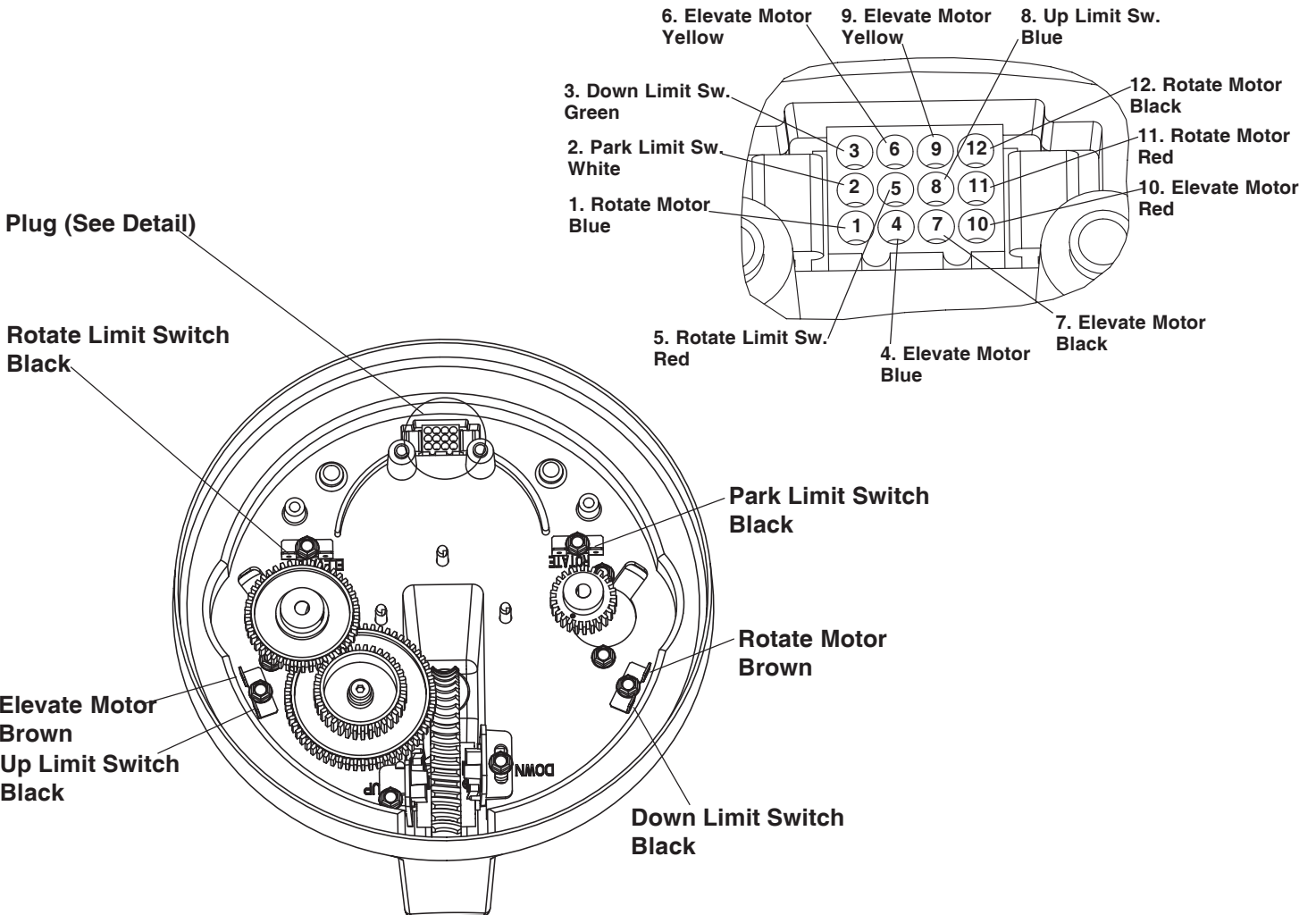
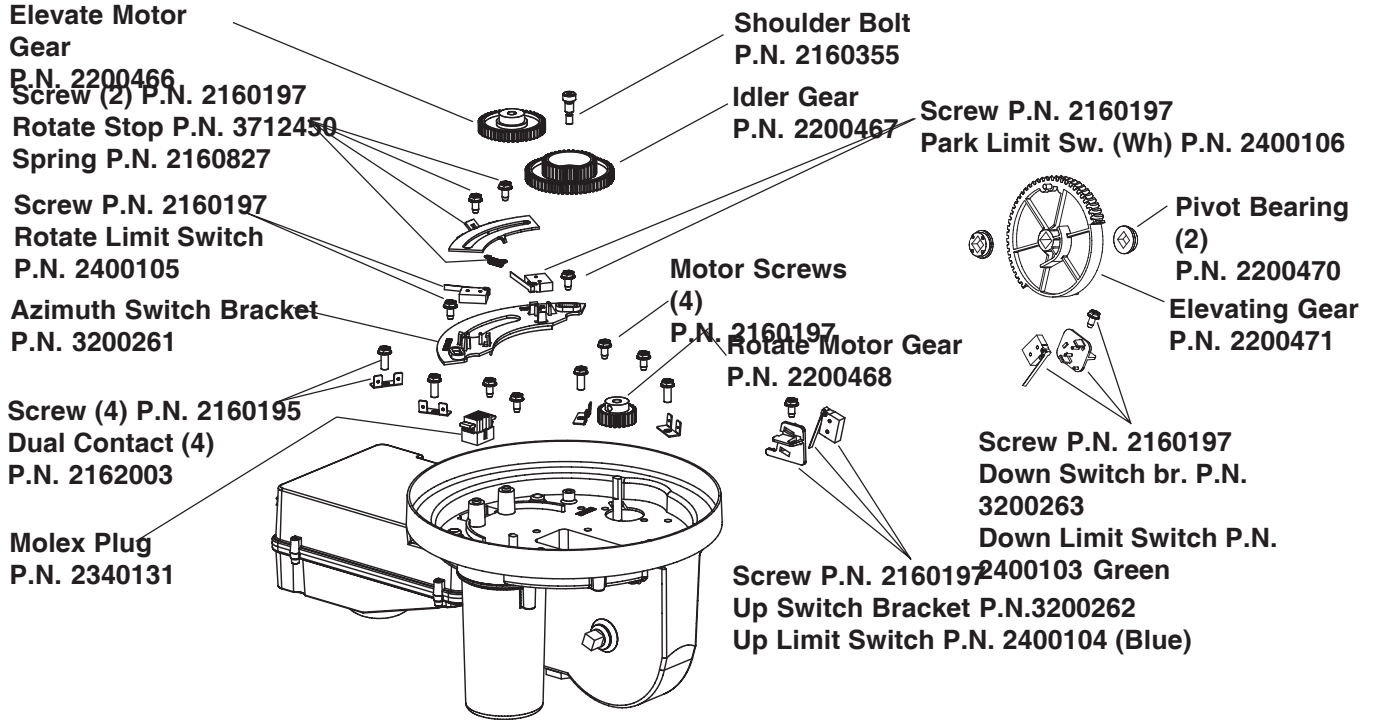

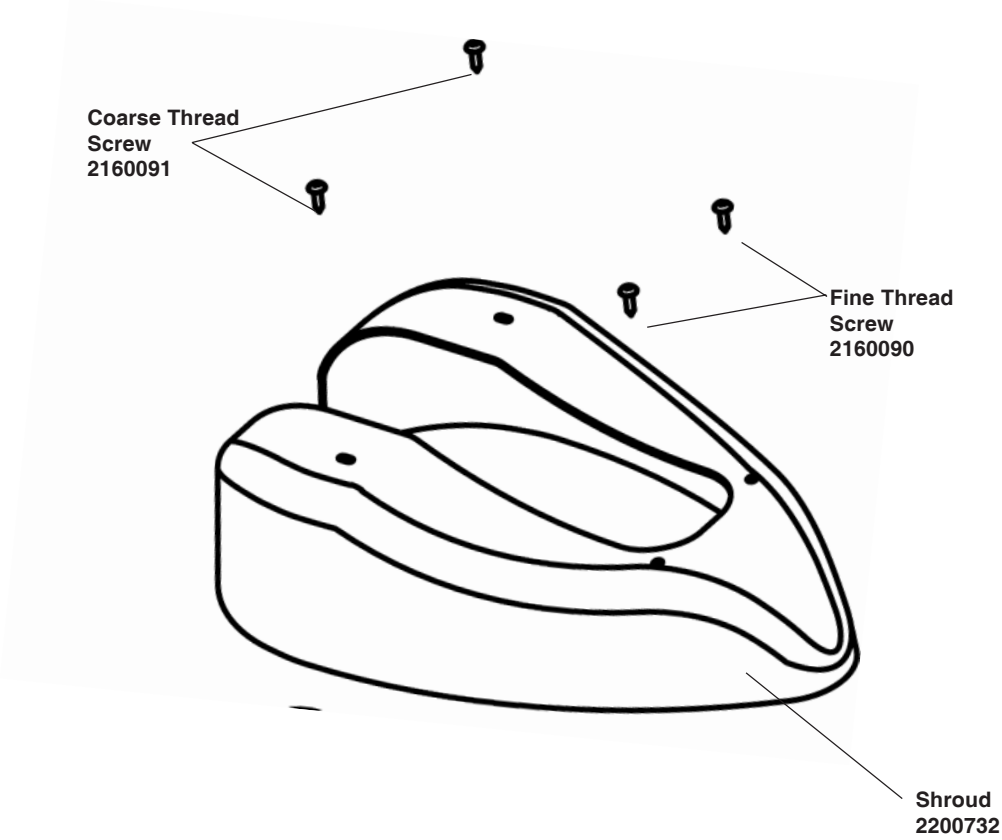

# Troubleshooting the system

---

This section of your manual will help you solve occasional problems with your unit. If you cannot solve the problem after using the suggestions in this section, contact the retailer or dealer where you purchased this unit, or call Winegard Technical Support at 1/800/-788-4417, Monday through Friday, 7:00 a.m. to 4:00 p.m., Central Time.

## UNIT WILL NOT PARK

1. Check unit on roof. Be sure there are no obstacles on the roof that prevent parking.
2. Was the PARK button on the wall plate controller pressed the correct number of times? See Control Panel Operation.
3. For the unit to park, the satellite receiver must be plugged into an active 120 VAC outlet, and the LNBF power from the receiver must be connected to the AS-2003. If this is not done, the unit will go to a “No LNBF Power” error (ON, PARK, SEARCH, OFF lighted) and will not park.

## UNIT WILL NOT PASS “CHECK SWITCH” FUNCTION (DISH Network only)

1. The receiver must report it is connected to a “SW42” switch. If you don’t see this report, your receiver cannot toggle between satellites. You may have to retest the Check Switch function occasionally.
2. AS-2003 limits the rotation of the turret to prevent damage to the cable assembly (diagram on page 8). If the vehicle is parked in a location that forces the unit to rotate all the way around each time it searches for a satellite signal, the Check Switch function will not be completed. Move your vehicle to face the unit in a different direction.
3. Be sure the “primary” coax is connected to the receiver that is operating the Check Switch routine, and that no devices are inserted on this coax between the satellite antenna and receiver.

## WALL PLATE ERROR CODES

### OFF & SEARCH LEDs are on —

Satellite search failure. The unit has failed to see the satellite(s) that are needed to determine the desired satellite signal, or the unit was stopped during the Search routine.

#### Solution

1. DBS (Direct Broadcast Satellite) satellite signals are in the south to southwest part of the sky. Be sure there are no obstructions (buildings, trees, mountains, etc.) that will block some or all of the satellite signals needed to determine the correct satellite signal for you.

### ON, PARK, SEARCH & OFF LEDs are on —

No LNBF power has been detected. The unit is not getting the required LNBF power from the receiver.

#### Solution

1. Be sure the satellite receiver is plugged into a functioning 120 VAC outlet.
2. Check for 11-18 VDC at the LNBF. Disconnect coax cable from LNBF and measure voltage between the copper center conductor (+) and the connector (-). There should be 11-18 VDC on this coax. If not present, check all coax connection from this point to the receiver. To check the output voltage at the receiver, connect a good piece of coax to the SATELLITE IN jack on the back of the receiver. DO NOT insert test light or meter probes directly into the receiver jack! You may enlarge the connector and cause a poor connection when coax is reconnected.
3. For new installations, be sure no screws from cable entry plate or clamps have penetrated the coax.

### ON & OFF LEDs are on —

A motor stall has occurred.

#### Solution

1. The unit has run into an obstacle on the roof while attempting to elevate or rotate. Visually inspect.
2. Cable length on roof too short, causing restriction while elevating or rotating. Check cable routing diagram for correct length and cable clamping.
3. Broken or pinched motor encoder wires, resulting in loss of encoder data.

**IF THERE IS AN ERROR CONDITION, CORRECT THE PROBLEM, THEN TURN THE UNIT OFF AND BACK ON TO CLEAR ERROR.**

## Testing Voltages to Check Electronics

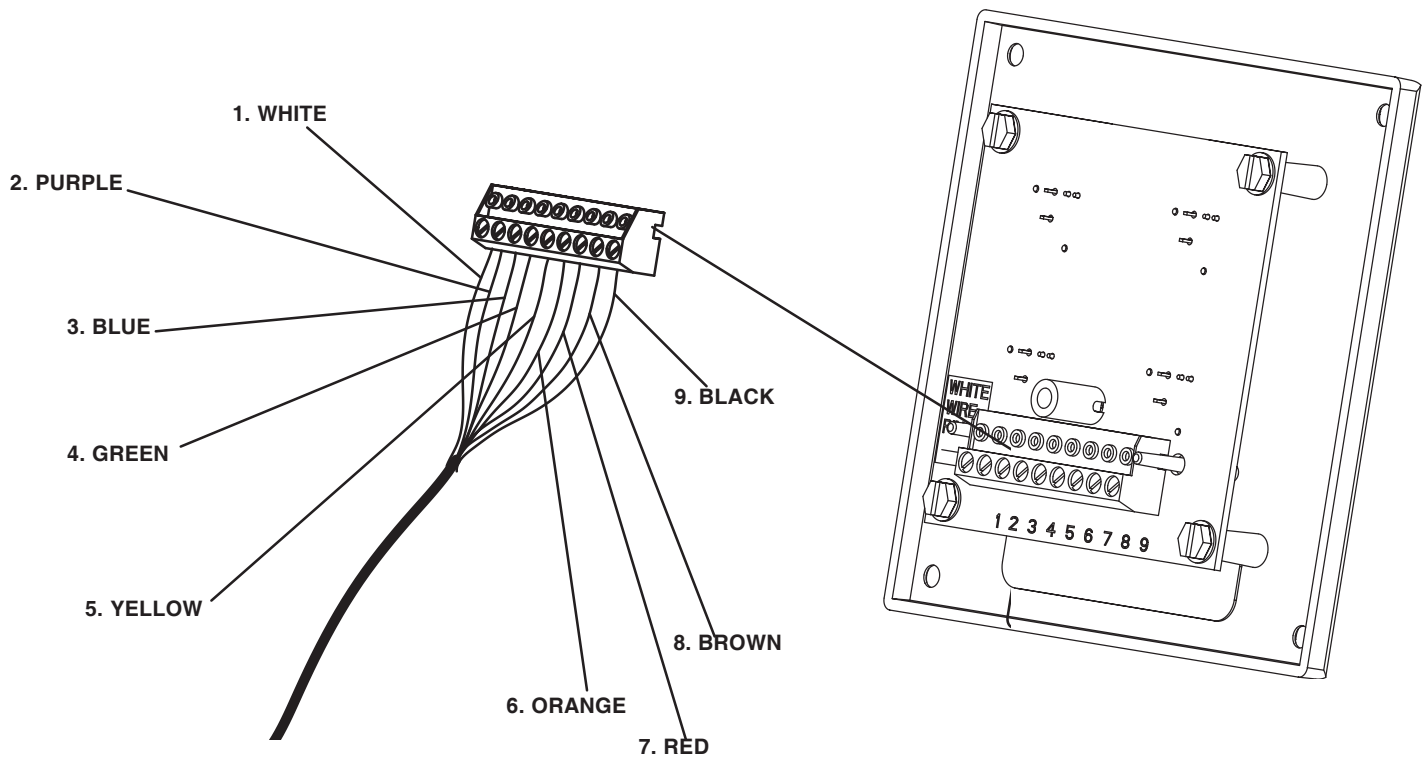

**CAUTION! Improper alignment of connector plug can cause system failure. USE EXTREME CARE when making connection. Unit MUST BE DISCONNECTED FROM POWER SOURCE before connecting.**

Measuring voltages present at wall plate control will aid in determining damaged circuitry in electronics housing.

Set voltage meter to DC and touch black meter lead (-) on meter to #9 screw terminal on wall plate connector. (Black wire - ground)

Touch red meter lead (+) to each of the colored wires listed below.

1. **White** wire voltage range 4.8 VDC - 5 VDC.  
(4.7 would indicate damaged circuitry in the electronics housing — replacement of electronics housing needed.)

**Symptom: Unit may not park.**

2. **Purple** wire voltage range 4.8 VDC - 5 VDC.  
(4.7 would indicate damaged circuitry in the electronics housing — replacement of electronics housing needed.)

**Symptom: Unit may fail to rotate or elevate.**

- 3 - 6. **Blue, green, yellow, orange.** These wires should measure .5 VDC or 1.8 VDC, depending on switch states.

7. **Red** wire will read supply voltage to the unit when wall plate is switched on.

8. **Brown** wire will read primary voltage supplied to unit (11 to 13.8 VDC)

9. **Black** wire is ground.

# Warranty

---

**Returned units damaged in shipping due to improper packing will be charged to the dealer/customer.**

**WINEGARD MOBILE PRODUCTS LIMITED WARRANTY  
(2 YEARS PARTS; 1 YEAR LABOR)**

Winegard Company warrants this product against defects in materials or workmanship for a period of two (2) years from the date of original purchase. During year one (1) of such warranty, Winegard Company will also pay authorized labor costs to repair or replace defective products. No warranty claim will be honored unless at the time the claim is made, Customer presents proof of purchase to an authorized Winegard dealer (to locate the nearest authorized Winegard dealer, contact Winegard Company, 3000 Kirkwood Street, Burlington, Iowa 52601, Telephone 319-754-0600). It is Customer's responsibility to verify the date of purchase by returning the warranty card included with the product to Winegard within thirty (30) days of the purchase. If a warranty card is not returned, Customer must provide proof of purchase with a dated sales receipt for the Winegard product to verify the product is under warranty. If the date of purchase cannot be verified, the warranty period shall be considered to begin thirty (30) days after the date of manufacture.

If a defect in material or workmanship is discovered and the product is returned before the expiration of the Warranty Period, Winegard Company will (at its option) either repair, replace or refund the purchase price of the product at no charge to Customer. Customer may mail or personally deliver the product to Winegard Warranty Services (located at 3000 Kirkwood Street, Burlington, Iowa 52601, Telephone 319-754-0600). Customer must return the product along with a brief description of the problem and provide Winegard Warranty Services with Customer's name, address, and phone number. If the warranty card is not on file for the particular product, Customer must also provide proof of purchase to verify the product is under warranty.

Alternatively, Customer may take the product to a Winegard Dealer for repair. If the warranty card is not on file for the particular product, Customer must provide proof of purchase to verify the product is under warranty. If the product was installed by a Winegard Dealer and is brought to a Winegard Dealer for repair prior to expiration of year one (1) of the Warranty Period, Winegard Company will cover the Winegard Dealer's labor charges for warranty repairs, provided the Winegard Dealer contacts Winegard Company in advance for pre-approval of the charges. Approval of the charges is in the sole discretion of Winegard Company. If approval is denied, Customer must mail or personally deliver the product to Winegard Warranty Services.

This Limited Warranty does not apply if the product has been damaged, deteriorates, malfunctions or fails from: improper installation, misuse, abuse, neglect, accident, tampering, modification of the product as originally manufactured by Winegard in any manner whatsoever, removing or defacing any serial number, usage not in accordance with product instructions or acts of nature such as damage caused by wind, lightning, ice or corrosive environments such as salt spray and acid rain.

**RETURN AUTHORIZATION POLICY**

A Return Material Authorization (RMA) is required prior to returning any product to Winegard Company or Winegard Warranty Services under this warranty policy. Please call our Technical Services Department at (800) 788-4417 or send an e-mail to [warranty@winegard.com](mailto:warranty@winegard.com) to obtain the RMA number. Please furnish the date of purchase when requesting an RMA number. Enclose the product in a postage-paid package and write the RMA number in large, clear letters on the outside of the package. To avoid confusion or misunderstanding, shipments without an RMA number or unauthorized returns will be refused and returned to Customer freight collect.

WINEGARD COMPANY DOES NOT ASSUME ANY LIABILITIES FOR ANY OTHER WARRANTIES, EXPRESS OR IMPLIED, MADE BY ANY OTHER PERSON.

ALL OTHER WARRANTIES WHETHER EXPRESS, IMPLIED OR STATUTORY INCLUDING WARRANTIES OF FITNESS FOR A PARTICULAR PURPOSE AND MERCHANTABILITY ARE LIMITED TO THE TWO YEAR PERIOD OF THIS WARRANTY.

In states that do not allow limitations on implied warranties, or the exclusion of limitation of incidental or consequential damages, the above limitations or exclusions do not apply.

Some states do not allow limitations on how long an implied warranty lasts, or the exclusion of limitation of incidental or consequential damages, so the above limitations or exclusions may not apply to you.

This warranty gives Customer specific legal rights. Customer may also have other rights that may vary from state to state.

**SATELLITE RECEIVER WARRANTY:**  
See manufacturer's limited warranty policy.

Rev. 10/24/05

