

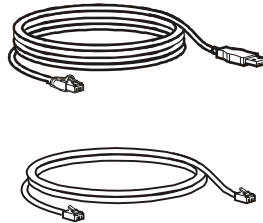

by Schneider Electric

Installation and Operation Back-UPS™ BX1300G/BN1350G/BX1500G

Inventory

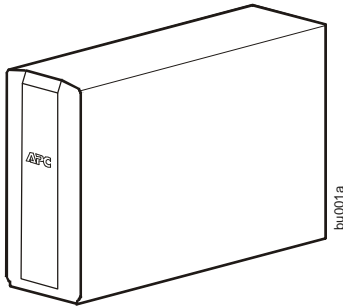

Safety and General Information

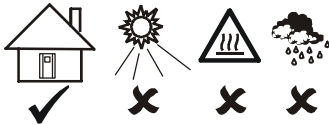

This unit is intended for indoor use only.

Do not operate this unit in direct sunlight, in contact with fluids, or where there is excessive dust or humidity.

The battery typically lasts for two to five years. Environmental factors impact battery life. Elevated ambient temperatures, poor quality AC power, and frequent short duration discharges will shorten battery life.

Connect the Back-UPS power cable directly into a wall outlet. Do not use surge protectors or extension cords.

Connect the Battery

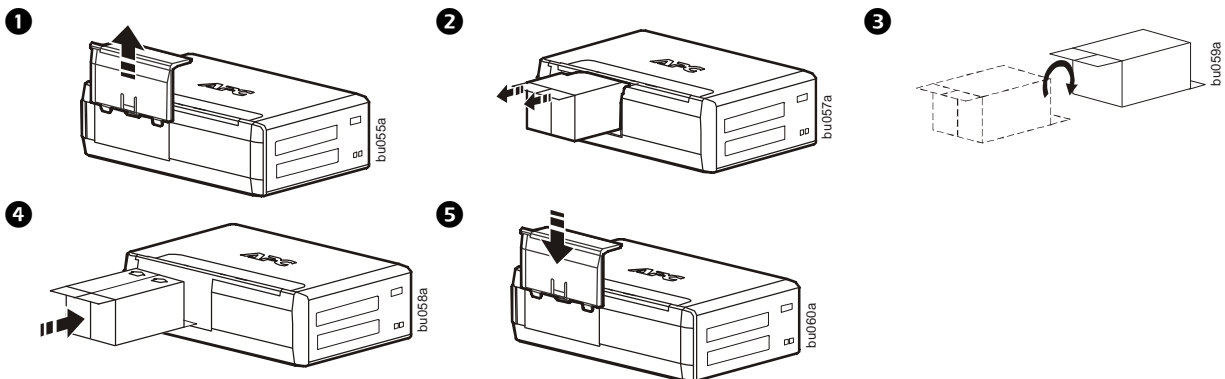

The battery charges fully during the first 16 hours while the Back-UPS is operating on AC power. Do not expect full battery runtime capability during the initial charge period.

Battery wear is not covered by the Limited Warranty.

There are no serviceable parts in the Back-UPS. Do not attempt to open or repair the Back-UPS as this will void the warranty. The battery in this unit is not replaceable. Contact APC through customer support. Refer to the contact information at the end of this manual.

PowerChute™ Personal Edition Software

Overview

PowerChute Personal Edition Software allows you to use your computer to access additional power protection and management features of the Back-UPS.

Using PowerChute, you can:

- Preserve work in progress during a power outage by putting your computer into Hibernate mode. When the power returns, the computer will appear exactly as it did before the power outage.
- Configure the Back-UPS management features, such as power-saving outlets, shutdown parameters, audible alarms, and more.
- Monitor and view the status of the Back-UPS, including the estimated runtime, power consumption, power event history, and more.

Available features will vary by Back-UPS model and operating system.

If you choose not to install PowerChute, the Back-UPS will still provide backup power and power protection to connected equipment. However, you will only be able to configure a limited number of features using the display interface.

Compatibility

PowerChute is compatible with Windows operating systems only. For a detailed list of supported operating systems, go to www.apc.com, select **Software & Firmware**.

For Mac operating systems, we recommend using the native shutdown application (within System Preferences) which recognizes your battery backup and allows you to configure shutdown of your system during power outages. To access this application, connect a USB cable from the Back-UPS DATA PORT (POWERCHUTE PORT) to a USB port on your computer, and see the documentation provided with your computer.

Installation

Connect the Back-UPS to a computer using a USB cable. Plug one end into the POWERCHUTE PORT on the rear panel of the Back-UPS and the other into a USB port on your computer.

Insert the PowerChute CD into your computer and follow the on-screen instructions. If your Back-UPS did not come with a PowerChute CD, download the software from www.apc.com, select **Software & Firmware**.

Connect the Equipment

- | | |
|---------------------------------------|---|
| 1 Telephone/ Network port | Connect a telephone cable to the In port, and a modem to the Out port. |
| 2 Data port | To use PowerChute Personal Edition, connect the supplied USB software cable or serial cable. |
| 3 Ground screw | Connect the ground lead from an additional surge suppression device such as a stand-alone data line surge protector. |
| 4 Building Wiring Fault LED | The LED illuminates when there is no ground circuit, an overloaded neutral, or there is a reversed polarity in the building wiring. Protection is not guaranteed when the LED is illuminated. Have a qualified electrician correct the building wiring. |
| 5 Controlled by Master outlets | These outlets provide surge protection for connected devices. To conserve energy the Controlled by Master outlets will disconnect from AC power whenever the device plugged into the MASTER outlet is turned off or goes into Standby or Hibernation mode. Connect a printer, scanner or other non-critical devices that do not require battery backup protection. |
| 6 Surge Protection outlets | These outlets provide full-time protection for connected equipment from power surges when the Back-UPS is turned on or off. The Surge Protection outlets do not provide battery backup to connected equipment. Connect a printer, scanner or other non-critical devices that do not require battery backup protection. |
| 7 AC power cable | Connect the Back-UPS to AC power. |
| 8 Battery Backup outlets | These outlets provide battery backup power to connected equipment for a limited period of time during power outages and voltage fluctuations. The Battery Backup outlets provide battery power to connected equipment only when the Back-UPS is turned on. Connect critical equipment such as desktop computer, computer monitor, modem or other data sensitive devices to these outlets. |
| 9 Master outlet | Connect the master device to this outlet, in most scenarios, this will be the main computer. |
| 10 Coaxial ports | Connect a modem or other device with coaxial connectors to the coaxial ports. |

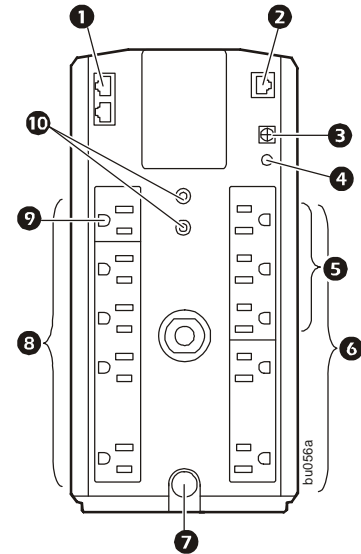

Turn On the Back-UPS

Press the Power ON button located on the top of the Back-UPS. The Power On LED will illuminate and a single short beep will be audible to indicate that the Back-UPS is providing protection for connected equipment.

The Back-UPS battery charges fully during the first 16 hours while connected to AC power. The Back-UPS battery will charge while the Back-UPS is switched on or off and is connected to AC power. Do not expect full battery runtime capability during the initial charge period.

If the red **Building Wiring Fault** LED located on the side of the Back-UPS illuminates, do not operate the Back-UPS. Have a qualified electrician correct the building wiring fault.

Operation

Power-Saving feature



This Back-UPS is equipped with power saving outlets that conserve electricity. Configure the Back-UPS to recognize a Master device, such as a computer or an A/V receiver, and controlled peripheral devices, such as a printer, speakers, or a scanner. When the Master device goes into Standby or Hibernation mode, or is turned off, the controlled device(s) will be turned off as well.

The Back-UPS ships with this Power-Saving feature DISABLED. To configure this feature, follow the instructions below or use PowerChute software.

Enable the Power-Saving Controlled outlets. Press and hold MUTE and DISPLAY buttons simultaneously for two seconds. The Back-UPS will beep to indicate the feature is enabled. The leaf icon on the display will illuminate.

Disable the Power-Saving Controlled outlets. Press and hold MUTE and DISPLAY buttons simultaneously for two seconds. The Back-UPS will beep to indicate the feature is disabled. The leaf icon on the display will extinguish.

Setting the threshold. The amount of power used by a device in Standby or Hibernation mode varies dependant on the connected device. If the Controlled outlets do not turn off when the Master device is in Standby or Hibernation mode, it may be necessary to adjust the threshold at which the MASTER outlet signals the CONTROLLED outlets to shut down.

1. Be sure a master device is connected to the MASTER outlet. Place that device into Standby or Hibernation mode, or turn it off.
2. Press MUTE and DISPLAY buttons simultaneously and hold for six seconds, until the leaf icon flashes three times and the Back-UPS beeps three times.
3. The Back-UPS will now recognize and save the threshold level as the new threshold setting for the master device.

Power-Saving LCD screen

The display interface can be configured to remain continuously illuminated or to extinguish after a period of inactivity to save electricity.

1. **Continuous Illumination mode:** Press and hold DISPLAY button for two seconds. The display will illuminate and the Back-UPS will beep to confirm **Continuous Illumination** mode is activated.
2. **Power-Saving mode:** Press and hold DISPLAY button for two seconds. The display will extinguish and the Back-UPS will beep to confirm **Power-Saving** mode is activated. While in **Power-Saving** mode, the display will illuminate if a button is pressed, it will extinguish after 60 seconds of inactivity.

Back-UPS sensitivity settings

The Back-UPS detects and reacts to line voltage distortions by transferring to battery backup power to protect connected equipment. In situations where either the Back-UPS or the connected equipment is too sensitive for the input voltage level it is necessary to adjust the transfer voltage.

1. Connect the Back-UPS to an AC power source. Be sure the Back-UPS is turned off.
2. Press and hold the POWER button for six seconds. The **load capacity** bar will flash on and off, to indicate the Back-UPS is in **Program** mode.
3. Press the POWER button again to scroll through the menu options. The Back-UPS will beep to confirm the selection. Refer to the table for an explanation of the transfer voltage sensitivity levels.

Generator Sensitivity



Low sensitivity
78-142 Vac

Use this setting with equipment that is less sensitive to fluctuations in voltage or waveform distortions.

Default



Medium sensitivity (Default)
88-139 Vac

Use this setting under normal operating conditions.

Sensitive Loads



High sensitivity
88-136 Vac

Use this setting when connected equipment is sensitive to any minor fluctuations in voltage or waveform distortions.









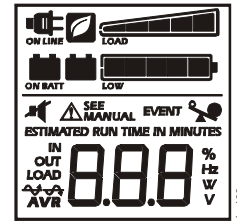
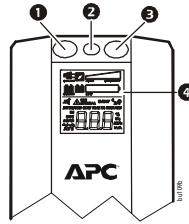







Front panel buttons and display

Use the buttons on the front panel of the Back-UPS and the display interface to configure the Back-UPS.

Front panel

- 1 MUTE button
- 2 POWER button
- 3 DISPLAY button
- 4 Display





 ON LINE	On Line: The Back-UPS is supplying conditioned AC power to connected equipment.
	Power-Saving Function: The MASTER and CONTROLLED outlets are enabled. The power-saving feature is active when the master device goes into Standby or Hibernation mode.
	Load Capacity: The load capacity percentage is indicated by the number of load bar sections illuminated. Each bar represents 20% of the load capacity.
	Estimated Run Time: This indicates the battery runtime minutes that remain if the Back-UPS switches to battery power.
	Battery Charge: The battery charge level is indicated by the number of load bar sections illuminated. When all five blocks are illuminated, the Back-UPS battery is fully charged. Each bar represents 20% of the battery charge capacity.
	Overload: The equipment connected to the Back-UPS is drawing more power than the voltage rating allows.
	Event: The event counter indicates the number of events that occurred to cause the Back-UPS to switch to battery operation.
	Automatic Voltage Regulation (AVR): The Back-UPS has “boost” and “trim” AVR that automatically regulates high or low levels of input voltage without using battery power. The Back-UPS also features AVR Bypass which temporarily deactivates the AVR circuitry when the input voltage is within normal range. This conserves battery power and helps to maximize battery life.  When illuminated, the Back-UPS is compensating for low input voltage.  When illuminated, the Back-UPS is compensating for high input voltage.
	In: Input voltage. Out: Output voltage.
	System Faults: An internal system fault has occurred. The fault number will illuminate on the display. See “Specifications” on page 9.
	Load: The total voltage, in watts and percentage used by the devices connected to the Battery Backup outlets.
	Mute: An illuminated line through the icon indicates that the audible alarm is disabled.
	Replace Battery: The battery is nearing the end of its service life. Replace the battery.
	On Battery: The Back-UPS is supplying battery backup power to the connected equipment.

Modes of operation

Press DISPLAY to scroll through the display screens.

On Line Mode	On Battery Mode
Input Voltage	Estimated runtime in minutes
Counter	Power Event Counter
Estimated run time	Output Voltage
Load in Watts	Input Voltage
Load in %	Load in Watts
Output Voltage	Load in %
Output Frequency	Output Frequency

Status indicators

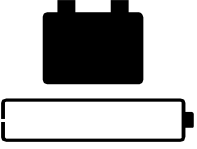



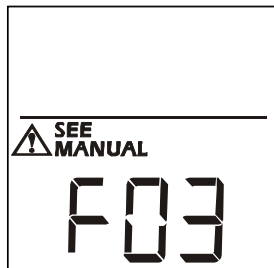







Status	LED	Audible Alarms	Audible Alarm Terminates
Overload An overload condition has occurred while operating on AC or battery power.		Constant tone	The alarm stops when nonessential equipment is disconnected from the Battery Backup outlets or the Back-UPS is turned off.
On Battery The Back-UPS is supplying battery power to the Battery Backup outlets.		Beeps 4 times every 30 seconds.	The beeping stops when AC power is restored or the Back-UPS is turned off.
Low Battery The Back-UPS is supplying battery power to the Battery Backup outlets and the battery is near a total discharge state.		Continuous beeping	The beeping stops when AC power is restored or the Back-UPS is turned off.

System faults



F01	On-Battery Overload	Turn the Back-UPS off. Disconnect non-essential equipment from the Battery Backup outlets and then turn Back-UPS on.
F02	On-Battery Output Short	Turn the Back-UPS off. Disconnect non-essential equipment from the Battery Backup outlets and then turn Back-UPS on.
F03	On-Battery Xcap Overload	Faults F03-F09 are not user serviceable. Contact APC Technical Support for assistance.
F04	Clamp Short	
F05	Charge Fault	
F06	Relay Welding	
F07	Temperature	
F08	Fan Fault	
F09	Internal Fault	

Feature Quick-Reference

Function	Button	Timing (seconds)	UPS Status	Description
Power				
POWER ON		0.2	Off	Press the POWER ON/OFF button to turn on the Back-UPS and operate on AC power. If AC input power is not available the Back-UPS will operate on battery power.
POWER OFF		2	On	Press the POWER ON/OFF button to turn off the Back-UPS. The Back-UPS will continue to provide surge protection to the Surge Protection outlets.
Display				
Status Inquiry		0.2	On	Verify the status or condition of the Back-UPS. The LCD will illuminate for 60 seconds.
Power-Saving mode: Continuous Illumination		2	On	The LCD will illuminate and the Back-UPS will beep to confirm Continuous Illumination mode is activated. The LCD will extinguish and the Back-UPS will beep to confirm that Power-Saving mode is activated. While in Power-Saving mode, the LCD will illuminate if a button is pressed, then extinguish after 60 seconds of no activity.
Mute				
Event Specific		0.2	On	Disable any audible alarms caused by an event.
General Status Enable/Disable		2	On	Enable or disable the audible alarms. The Mute icon will illuminate and the Back-UPS will beep one time. The Mute feature will not activate unless the Back-UPS is operating on battery power.
Sensitivity		6	Off	The Load Capacity icon will flash to indicate the Back-UPS is in Program mode. Use the POWER ON/OFF button to scroll through and select Low, Medium, and High sensitivity levels. The Back-UPS will beep to confirm the selection. Refer to “Back-UPS sensitivity settings” on page 4 for details.
MASTER/CONTROLLED outlet Enable/Disable		2	On	The leaf icon will extinguish to indicate the MASTER outlet feature is disabled or illuminate to indicate the MASTER outlet feature is enabled. The Back-UPS will beep once.
Master/Enable threshold calibration		6	On	While calibrating the threshold setting, the device connected to the MASTER outlet should be turned off or placed in Standby or Sleep mode. Once the threshold setting has been selected the Power-Saving icon will flash 3 times and beep 3 times.
Self-Test (manual)		6	On	The Back-UPS will run a test of the internal battery. Note: This will happen automatically when the Back-UPS is turned on.
Event Reset		0.2	On	When the Event screen is visible, press and hold DISPLAY, then press the POWER button to clear the AC failure event counter.
Fault Reset		2	Fault	After a fault has been identified, press the POWER ON/OFF button to remove the visual indication and return to standby status.

Troubleshooting

Problem	Possible Cause	Corrective Action
Back-UPS will not turn on.	The Back-UPS is not connected to AC power.	Be sure that the Back-UPS is securely connected to an AC outlet.
	The circuit breaker has been tripped.	Disconnect non-essential equipment from the Back-UPS. Reset the circuit breaker. Re-connect equipment one item at a time. If the circuit breaker is tripped again, disconnect the device that caused the event.
	The internal battery is not connected.	Connect the battery.
	The AC input voltage is out of range.	Adjust the transfer voltage and sensitivity range.
The Back-UPS is operating on battery power, while connected to AC power.	<ul style="list-style-type: none"> • The Back-UPS power cord is not securely connected to the wall outlet. • The wall outlet is no longer receiving AC power. • The circuit breaker has been tripped. 	Verify that the plug is fully inserted into the wall outlet. Verify that the wall outlet is receiving AC power by checking it with another device.
	The Back-UPS is performing an automatic self test.	No action is necessary.
	<ul style="list-style-type: none"> • The AC input voltage is out of range. • The frequency is out of range. • The waveform is distorted. 	Adjust the transfer voltage and sensitivity range.
The Back-UPS does not provide the expected amount of backup time.	The Back-UPS may be experiencing an overload condition.	Disconnect non-essential equipment from the Battery Backup outlets.
	The battery was recently discharged due to a power outage and has not fully recharged.	Charge the battery for eight hours.
	The battery has reached the end of its service life.	Replace the battery.
The BATTERY and ONLINE LEDs are flashing alternately.	The battery has reached the end of its service life.	Replace the battery.
The BATTERY LED is illuminated and the Back-UPS emits a constant tone.	The equipment connected to the Back-UPS is drawing more power than the Back-UPS can provide.	Disconnect non-essential equipment from the Battery Backup outlets.
The Building Wiring Fault LED illuminates.	The building wiring presents a shock hazard that must be corrected by a qualified electrical.	Do not operate the Back-UPS. Call a qualified electrician to correct the building wiring fault.

Specifications

Model	1500 VA	1350 VA	1300 VA
Maximum Load	865 W	810 W	780 W
Nominal Input Voltage	120 Vac		
Online Input Voltage Range	88 Vac to 139 Vac		
Automatic Voltage Regulation	+ 11.5% Boost Only		
Frequency Range	50/60 Hz \pm 1 Hz		
On battery Waveshape	Step approximated sinewave		
Typical Recharge Time	16 hours		
Transfer Time	8 ms, maximum		
Operating Temperature	0° to 40° C (32° to 104° F)		
Storage Temperature	-5° to 45° C (23° to 113° F)		
Unit Dimensions	11.9 \times 4.4 \times 15.0 in (30.1 \times 11.2 \times 38.2 cm)		
Unit Weight	23.8 lbs (10.8 kg)	22.8 lbs (10.4 kg)	
Interface	USB		
On Battery Runtime	Go to: http://www.apc.com/product		
EMI Classification	FCC / DOC Class B Certified		

Service

If the unit requires service, do not return it to the dealer. Follow these steps:

1. Review the TROUBLESHOOTING section of the manual to eliminate common problems.
2. If the problem persists, contact APC Customer Support.
 - a. Note the model number and serial number and the date of purchase. The model and serial numbers are located on the rear panel of the unit and are available through the LCD display on select models.
 - b. Call APC Customer Support and a technician will attempt to solve the problem over the phone. If this is not possible, the technician will issue a Returned Material Authorization Number (RMA#).
 - c. If the unit is under warranty, the repairs are free.
 - d. Service procedures and returns may vary internationally. Refer to the APC Web site for country specific instructions.
3. Pack the unit properly to avoid damage in transit. Never use foam beads for packaging. Damage sustained in transit is not covered under warranty. **For the UPS, always DISCONNECT THE BATTERY before shipping in compliance with U.S. Department of Transportation (DOT) and IATA regulations.** The battery may remain in the unit.
4. Write the RMA# provided by Customer Support on the outside of the package.
5. Return the unit by insured, pre-paid carrier to the address provided by Customer Support.

APC Customer Support Worldwide

Internet

<http://www.apc.com/support>

Warranty

The standard warranty is two (2) years from the date of purchase. APC standard procedure is to replace the original unit with a factory reconditioned unit. Customers who must have the original unit back due to the assignment of asset tags and set depreciation schedules must declare such a need at first contact with an APC Technical Support representative. APC will ship the replacement unit once the defective unit has been received by the repair department, or cross-ship upon the receipt of a valid credit card number. The customer pays for shipping the unit to APC. APC pays ground freight transportation costs to ship the replacement unit to the customer.

Customer support and warranty information is available at the APC Web site, www.apc.com.

© 2012 APC by Schneider Electric. APC, the APC logo, PowerChute and Back-UPS are owned by Schneider Electric Industries S.A.S., American Power Conversion Corporation, or their affiliated companies. All other trademarks are property of their respective owners.

EN 990-3508E
05/2012