

Operating Instructions

Mast Mounted Outdoor Antenna Amplifier

Installation Instructions

1. Place pre-amplifier unit on the antenna mast approximately 3 feet below the antenna.
2. Use mast clamp and wing nuts provided to secure the pre-amplifier unit to the mast.
3. Connect the antenna terminals to the input terminals of the pre-amplifier unit. This connection may be made using either 300 ohm twin lead or 75 ohm coaxial cable. See below for specific instructions.

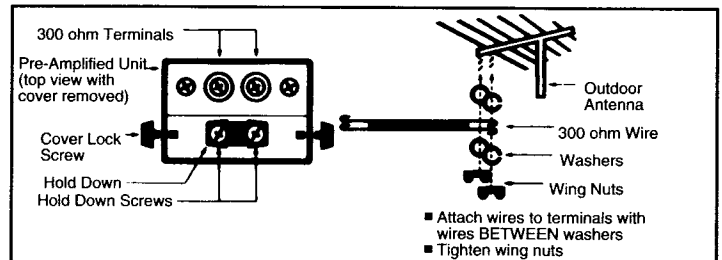

300 ohm Twin Lead

Split 300 ohm lead about 6 inches and then strip off 1 inch of insulation on each end of the lead. Attach one end of the lead wire to the antenna and the other end to the pre-amplifier inputs. The pre-amplifier input terminals are reached by removing the weatherproof cover. This can be done by loosening (not removing) the cover lock screws and lifting off the weatherproof cover. Attach the leads to the 300 ohm terminals, be sure to place the wire under the hold down (see illustration).

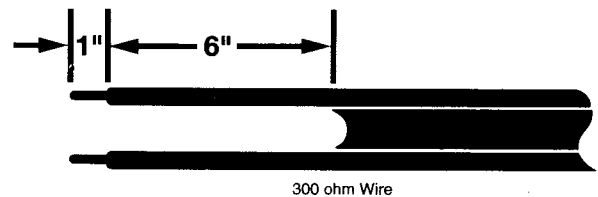

- Split antenna lead-in wire about six inches
- Strip insulation back about one inch

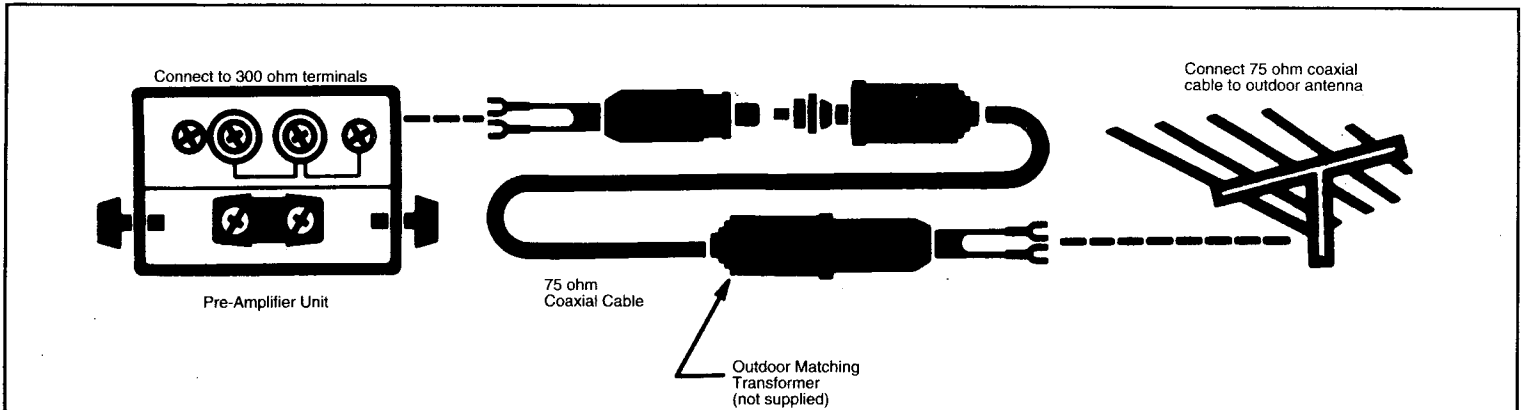

75 ohm Coaxial Cable

Use an outdoor matching transformer (not included) to attach the coaxial cable to the antenna terminals. There are two ways to attach the coaxial cable to the pre-amplifier unit.

1. Use another matching transformer to attach the coax cable to the terminals marked 300 ohm.
2. Strip back the outer jacket 2.5 inches. Then twist the braid to form a lead. Cut off 1 inch of the inner foam insulation exposing the center conductor. Place the coaxial cable under the hold down and connect the center conductor under the left hand terminal and the braid under the right hand terminal.

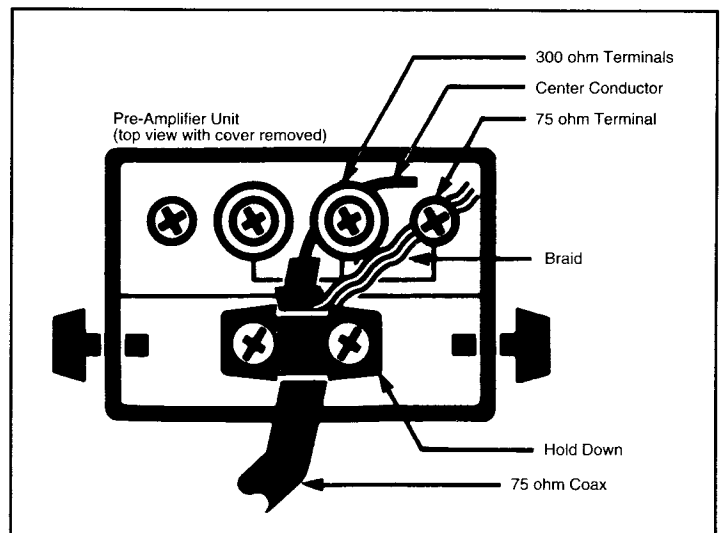

Connection: Pre-Amplifier to Amplifier

There is a slide switch on base of pre-amplifier unit, from 75 ohm to 300 ohm which is used to select cable type installed on the output terminal.

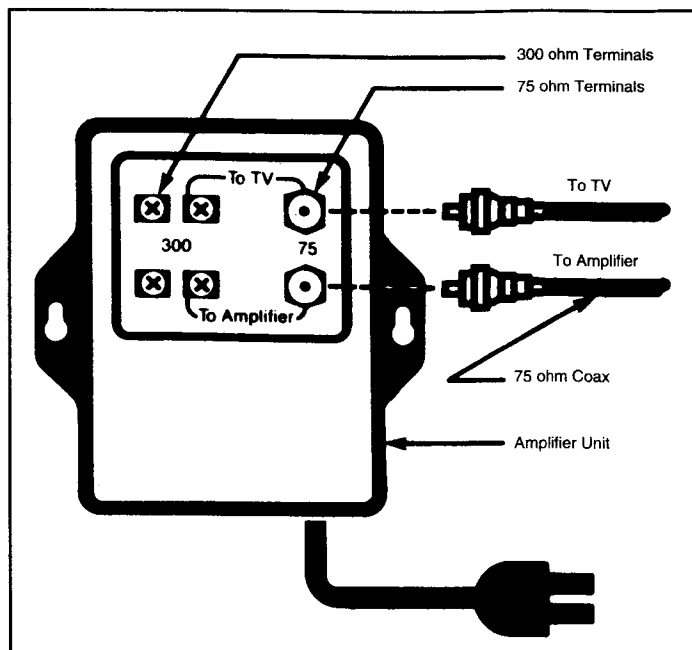
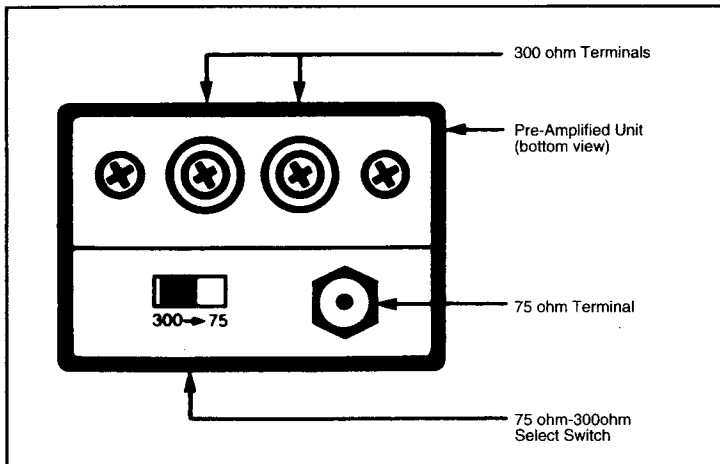

When coaxial cable is used it is terminated with an "F" connector and connected to the 75 ohm terminal on the pre-amplifier and the 75 ohm terminal on the amplifier unit labeled "to amplifier".

When 300 ohm twin lead is used, it is connected to the two 300 ohm terminals on the pre-amplifier unit labeled "to amplifier". The switch is then thrown to the side labeled 300.

Connection Amplifier to TV

Using the same type of lead wire (75 ohm or 300 ohm) use to connect the pre-amplifier to the amplifier, connect the amplifier unit to the TV. Be sure to use the appropriate band separator to split VHF signals and UHF signals.

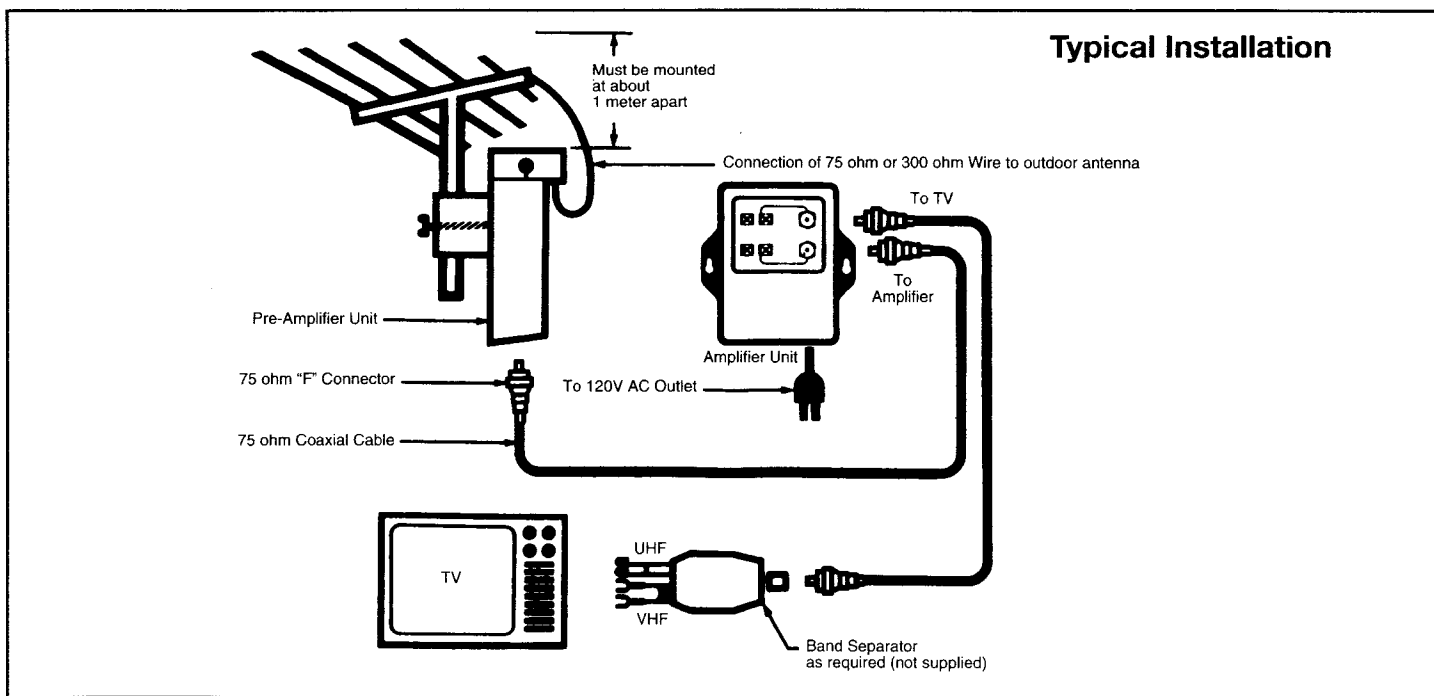

Performance Specifications:

Pre-Amplifier

Bandwidth _____ 40-860 MHz
 Gain _____ V:28 dB U:22 dB
 Max. Output Level _____ 105 dB Micro V
 Input Impedance _____ 75/300 ohms
 Output Impedance _____ 75/300 ohms
 Noise Figure _____ 4 dB/below AT500 MHz
 Applicable Temp _____ -20°C- +50° C

Amplifier

Input Voltage _____ AC120V
 Output Voltage _____ AC24V
 Input Impedance _____ 75/300 ohms
 Output Impedance _____ 75/300 ohms