

# TRICITY BENDIX

we'll do the homework.

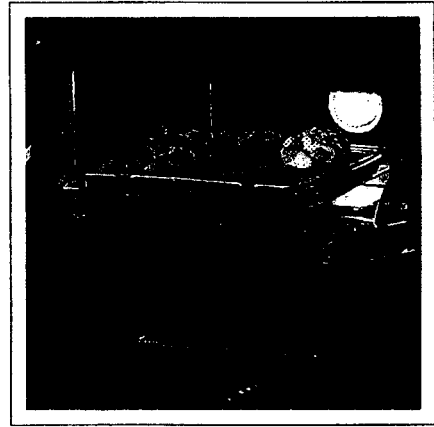
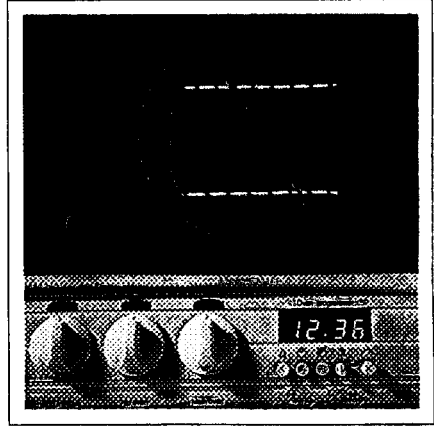

600mm Built-in Oven  
Operating Instructions

## COOKERS



**IMPORTANT**

PLEASE READ THIS  
INSTRUCTION BOOK  
BEFORE USING THE  
APPLIANCE

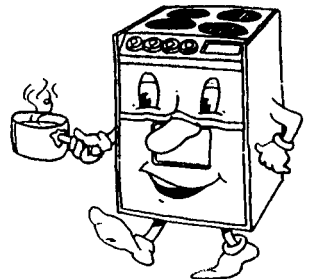

Please refer to the sections in this book as appropriate to the features on your particular model.

	Page
<b>Preface</b> .....	3
<b>Safety</b>	
Before installing your appliance .....	4
While operating your appliance .....	4
After using your appliance .....	5
Taking care of your appliance .....	6
<b>Introduction</b>	
Installation .....	7
Getting to know your oven (BS610 Series) .....	7
Getting to know your oven (BS620 Series) .....	7
Getting to know your oven (BS630 Series) .....	7
The control panel symbols .....	7
General notes on using the oven .....	7
Before use .....	7
When first switching on .....	8
During use .....	8
About condensation and steam .....	8
Shelves .....	8
Cookware .....	8
The trivet .....	8
The cooling fan for the controls .....	8
<b>The grill</b>	
The grill pan handle .....	9
Uses of the grill (BS610 & 620 series) .....	10
How to select thermal grill .....	10
Things to note .....	10
How to select the full heat grill .....	11
Things to note .....	11
Hints and tips .....	12
Uses of the Grill (BS630 series) .....	13
Selecting the grill .....	13
Things to note .....	13
Hints and tips .....	12
Grilling chart .....	14
<b>How to use the oven</b>	
Uses of the fan oven .....	15
Selecting the fan oven (BS610 & BS620 Series) .....	15
Selecting the fan oven (BS630 Series) .....	16
Things to note .....	16
Hints and tips .....	16
Defrost	
Uses of defrost .....	17
Selecting defrost (BS610 & BS620 Series) .....	17
Selecting defrost (BS630 Series) .....	18
Things to note .....	18
Hints and tips .....	18

**Additional multifunction modes (BS630 Series only)**

The conventional oven	
Uses of the conventional oven .....	19
Selecting conventional oven .....	19
Things to note .....	19
Hints and tips .....	19
The zoned oven	
Uses of the zoned oven .....	21
Selecting the zoned oven .....	21
Things to note .....	21
Hints and tips .....	21
Thermal grilling	
Uses of thermal grilling .....	23
Selecting thermal grilling .....	24
Things to note .....	24
Hints and tips .....	24
Thermal Grilling Chart.....	14
Oven clean	
Uses of oven clean .....	26
Selecting oven clean .....	26
Things to note .....	26
Hints and tips .....	26
<b>How to use the timer BS610 Series .....</b>	<b>28</b>
<b>How to use the automatic timer</b>	
BS620 Series .....	29
BS630 Series .....	32
<b>Recommended cooking temperatures .....</b>	<b>36</b>
<b>Helpful hints when buying and preparing food .....</b>	<b>37</b>
<b>Care and cleaning</b>	
Care and cleaning .....	38
Cleaning materials .....	38
Cleaning the outside of the oven .....	38
Cleaning the oven door .....	38
To remove the oven door .....	38
Cleaning inside the oven door .....	39
Cleaning inside the oven .....	40
Cleaning the oven shelves and grill pan .....	41
Care of stayclean surfaces .....	41
Hints and tips .....	41
Cooking to reduce soilage .....	41
<b>Something not working? .....</b>	<b>42</b>
<b>Service and spare parts</b>	
Help us to help you .....	44
Customer service centres .....	45

Dear Customer,

Thank you for buying a Tricity Bendix built-in oven. With our 80 years experience in developing and manufacturing the very best in U.K. cookers, you can be assured that you have purchased a hard working, reliable, quality product.

In addition, Tricity Bendix cookers comply with British Standard safety and performance requirements. They have been approved by BEAB (British Electrotechnical Approvals Board) and are covered by a 12 month parts and labour guarantee.

In order that you can get the best from your new Tricity Bendix cooker, the following instructions have been prepared. PLEASE MAKE SURE YOU READ THEM CAREFULLY. Particular attention should be paid to cooking times and temperatures as they may differ from your previous cooker.

It is most important that this instruction book should be retained with the appliance for future reference. Should the appliance be sold or transferred to another owner, or should you move house and leave the appliance, always ensure that the book is supplied with the appliance so that the new owner can be acquainted with the functioning of the appliance and the relevant warnings. Please ensure that you have read the whole instruction book before using the appliance and that you follow the recommendations given.

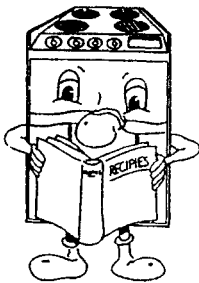

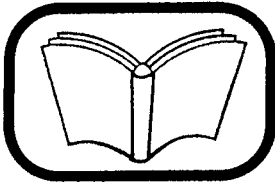

## WARNINGS – ELECTRIC COOKERS

These warnings are provided in the interests of your safety. You must carefully read and understand them all before installing or using the appliance.

### 1 BEFORE INSTALLING YOUR APPLIANCE

- ▼ This appliance is heavy and care must be taken when moving it.



- ▼ Ensure that all packaging, both inside and outside the appliance has been removed before the appliance is used.

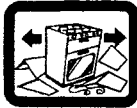

- ▼ Do not try to move the appliance by pulling the door handle. Refer to installation instructions.



- ▼ The appliance must be installed according to the instructions supplied. Any electrical installation work must be undertaken by a qualified electrician.

- ▼ It is dangerous to alter the specifications or modify the product in any way.



### 2 WHILE OPERATING YOUR APPLIANCE

- ▼ This appliance is designed to be operated by adults and children under supervision. Young children must not be allowed to tamper with the controls or play with or near the product.



- ▼ CAUTION—Accesible parts may become hot when the appliance is in use. Children should be kept away.

- ▼ Ensure that all control knobs are in the off position when not in use.



- ▼ Fats and oils will ignite if they become too hot.



Take great care to prevent fats and oils overheating.



- ▼ This product has been designed for cooking edible foodstuffs only, and must not be used for any other purposes.

- ▼ Do not use this appliance if it is in contact with water. Similarly never operate it with wet hands.



- ▼ Never place plastic or any other material which may melt in or on the oven itself.



- ▼ Ensure cooking utensils are large enough to contain foods and prevent spillages and boil overs.



- ▼ Take care to follow the recommendations given for tending the food when grilling. Use the handle provided in the recommended way (see page 9).



- ▼ Use oven gloves if necessary to remove and replace the grill pan handle and when grilling.



- ▼ Support the grill pan when it is in the withdrawn or partially withdrawn position.



- ▼ Ensure that all vents (where fitted) are left unobstructed to ensure ventilation of the oven cavity.

- ▼ Never line any part of the appliance with aluminium foil.

- ▼ Always stand back from the appliance when opening the oven door to allow any build up of steam or heat to release.



- ▼ Stand clear when opening the drop-down oven door. Do not allow it to fall open – support it using the door handle, until it is fully open.



- ▼ Do not place sealed cans or aerosols inside the oven. They may explode if they are heated.



### 3 AFTER USING YOUR APPLIANCE

- ▼ For hygiene and safety reasons this appliance should be kept clean at all times. Do not leave utensils containing foodstuffs, e.g. fat or oil in or on the appliance in case it is inadvertently switched on. A build-up of fats or other foodstuffs could result in a fire.



- ▼ Cookers and hobs become very hot, and retain their heat for a long period of time after use. You must therefore take care when using the appliance. Supervise children at all times and do not allow them to touch the cooker or hob surface or be near the appliance until it has cooled after use.

## 4 TAKING CARE OF YOUR APPLIANCE

- ▼ Under no circumstances should you attempt to repair or service the appliance yourself. Repairs carried out by inexperienced persons may cause injury or serious malfunction. This product should be serviced by an authorised Service Engineer and only genuine approved spare parts should be used. Details of servicing and repair arrangements are supplied at the back of this instruction book.



- ▼ Do not stand on the appliance or on the open oven doors.



- ▼ Do not hang towels, dishcloths or clothes from the appliance or its handles. They are a safety hazard.



- ▼ Always switch off the cooker at its power point and allow the appliance to cool before any maintenance or cleaning work is carried out.



- ▼ Only clean this appliance in accordance with the instructions given in this book.



- ▼ Your safety is of paramount importance, therefore if you are unsure about any of the meanings of these warnings contact the Customer Relations Department. Telephone Number 0992 469080.

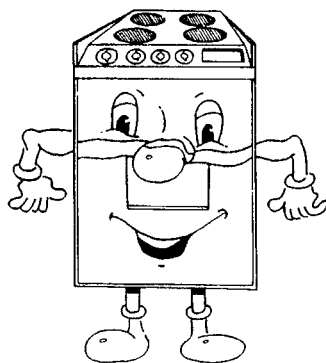



## INSTALLATION

The appliance must be installed by a qualified electrician in accordance with the installation instructions provided.

This appliance complies with Radio Interference requirements of EEC Directive 82/499/EEC.



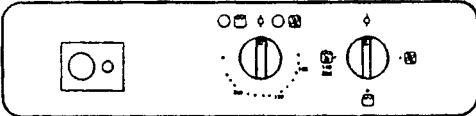
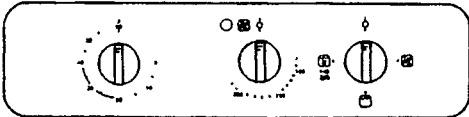
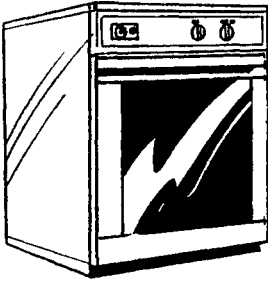





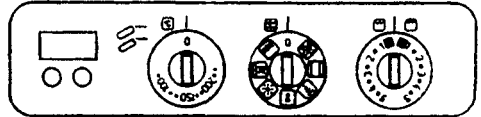
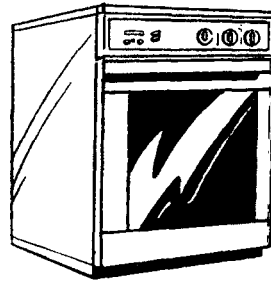

### GETTING TO KNOW YOUR OVEN (BS610 & BS620 Series)



-  Full Grill
-  Thermal Grilling
-  Fan Oven

### GETTING TO KNOW YOUR OVEN (BS630 Series)



-  Temperature
-  Thermal Grilling
-  Multifunction Oven
-  Fan Oven
-  Defrost
-  Zoned Oven
-  Full Grill (■)
-  Conventional Oven
-  Dual Grill
-  Centre Section Grill (■)
-  Oven Clean

## GENERAL NOTES ON USING YOUR OVEN

### BEFORE USE

Allow all elements to run for a short period to burn off any residue from their surface. If the odour emitted during the initial burning off is unpleasant it may be necessary to open a window for ventilation.



## **WHEN FIRST SWITCHING ON**

### **(BS620 & BS630 Series only)**

The timer must be set to manual before the oven can be operated. See page 31, for BS620 Series, see page 34 for BS630 Series. This must be done whenever the appliance is switched on or there has been a power failure.

If the oven indicator neon does not glow when the oven control dial is turned on, it is most likely that the cooker timer is set for automatic cooking.

## **DURING USE**

The cooker has passed all the appropriate temperature and safety requirements. However, when using various parts of the cooker certain areas may become hot.

## **ABOUT CONDENSATION AND STEAM**

When food is heated it produces steam in the same way as a boiling kettle does. The oven is vented to allow the steam to escape and prevent excessive build-up inside. If the steam comes into contact with a cool surface on the outside of the appliance, e.g. a trim, it will condense and produce water droplets. It may be necessary to wipe over the cooker occasionally to remove any droplets of water. This is quite normal and is not caused by a fault on the appliance.

Surfaces in close contact with the oven vent should be regularly wiped to reduce soilage and discolouration from cooking vapours.

## **COOKWARE**

Baking trays, oven dishes etc. should not be placed directly against the grid covering the fan at the back of the oven. Do not use baking trays larger than 30cm x 35cm (12in x 14in) as they will restrict the circulation of heat and may affect performance. Advice on the affect of different materials and finishes of dishes and tins is given in 'Hints and Tips' in the appropriate oven section.

## **THE TRIVET (BS630 Series)**

When roasting use the trivet in the meat tin. Fat and meat juices will drain into the meat tin below and can be used to make delicious gravy. The trivet also prevents splashes of fat from soiling the inside surface of the oven.

## **THE COOLING FAN FOR THE CONTROLS**

This runs continuously when either of the ovens or the grill is in use. This ensures that the controls remain at a safe temperature and helps to ventilate the oven.



## THE GRILL PAN HANDLE

To attach the handle, locate the curved edge over the edge of the grill pan above the bracket and lower into position. To remove, tilt the handle upwards.

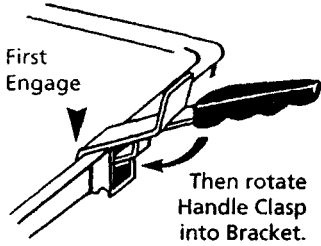

To secure the grill pan on the shelf, ensure that the cut out on the underside of the handle bracket locates over the inner shelf location bar (if present), or outer shelf frame, whichever is appropriate.

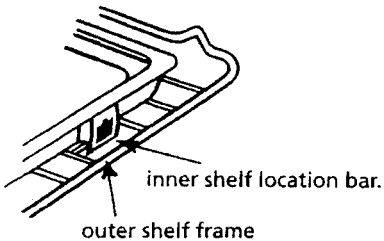

To check the progress of food being grilled, the grill pan should be withdrawn on the shelf to attend to food during cooking.

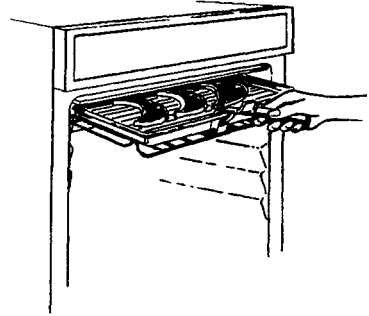



For BS630 Series turn to page 13.

## 1.1 USES OF THE GRILL

Two grilling functions are available .

1. Thermal grilling.
2. Full heat grilling.

When thermal grilling is selected the grill element and oven fan operate together, circulating hot air around the food. The need to check and turn food is reduced and, because the oven door is closed during thermal grilling, cooking smells in the kitchen are reduced.

Use the full heat grill only for foods which require high heat and short cooking times e.g. toast, blue/rare steaks. Use thermal grilling to grill all other foods e.g. bacon, chops, sausages, chicken joints etc. See chart on page 14 for recommended cooking times, temperatures and shelf positions.

## 1.2 HOW TO SELECT THE THERMAL GRILL

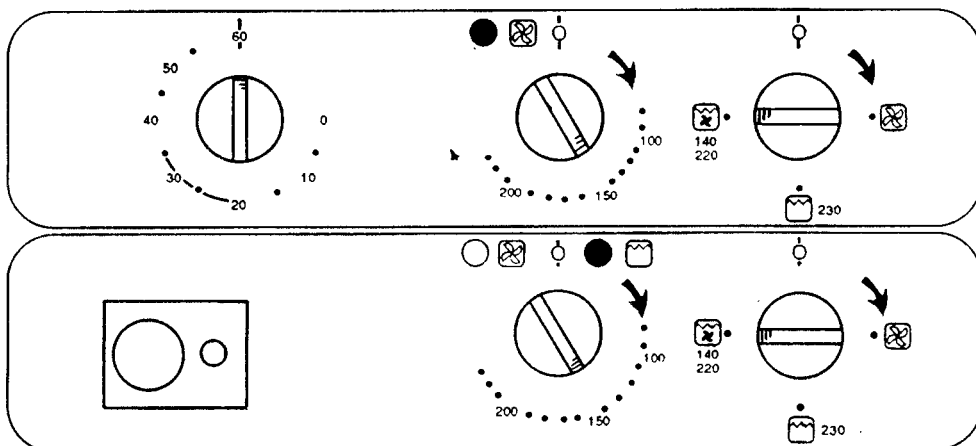

- 1 Turn the selector to thermal grill.  
**WARNING:** Do not Auto-time this function (BS 620 Series).
- 2 Turn the temperature control to the required setting.

A temperature between 140°C and 220°C is normally used. You can use higher or lower temperatures if you wish.

### NOTE

- 1 The grill neon indicator will glow (BS620 Series)
- 2 The control cooling fan will operate in conjunction with the thermal grilling function.

## 1.3 THINGS TO NOTE

- ▼ Always thermal grill with the door closed and with handle removed.
- ▼ To achieve variable grilling use the thermal grill function with the oven door closed.



## 1.4 HOW TO SELECT THE FULL HEAT GRILL

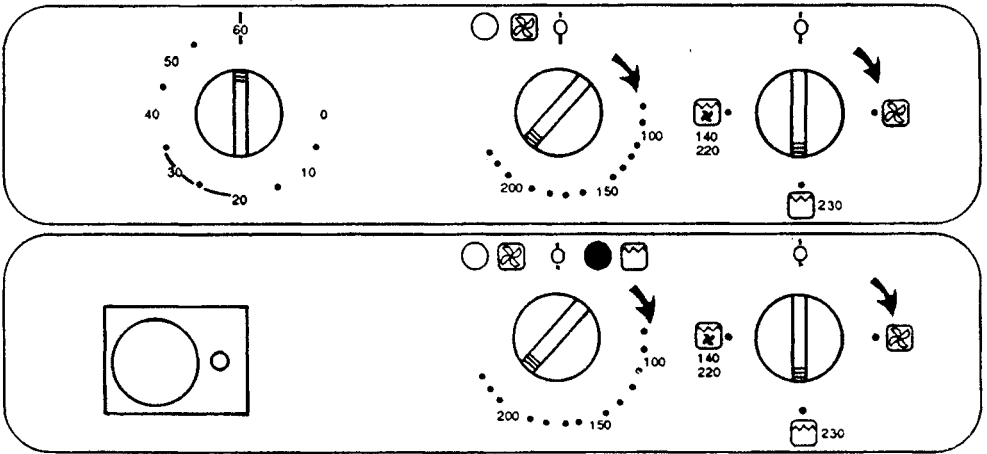

- 1 Turn the selector to full heat grill.
- 2 Turn the temperature control to full setting.

### NOTE

- 1 The grill indicator neon will glow (BS620 Series)
- 2 The control cooling fan will operate in conjunction with the full heat grill.

## 1.5 THINGS TO NOTE

- 1 Always grill with the door fully open
- 2 If the oven thermostat is turned down while the full heat grill is selected, the grill element will be 'on' then 'off' for long periods of time and may not give the expected results. It is therefore strongly recommended that the thermal grilling function is used for foods which require the grill to be turned down.
- 3 See text on page 12.

## 1.6 HINTS AND TIPS

- ▼ Most foods should be placed on the grid in the grill pan to allow maximum circulation of air to lift the food out of the fats and juices. Foods such as fish, liver and kidneys may be placed directly on the trivet in the grill pan, if preferred.

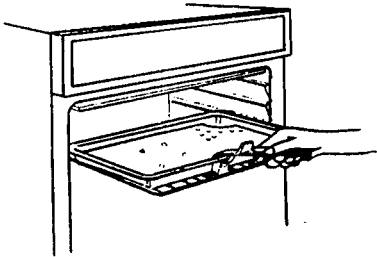

- ▼ Adjust the grid and grill pan runner position to allow for different thicknesses of food. Position the food closer to the element for faster cooking and further away for more gentle cooking.

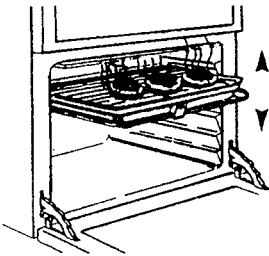

- ▼ Prepare foods for grilling by washing and drying them, as necessary. Brush lean meats and fish lightly with a little oil or butter to keep them moist during cooking.

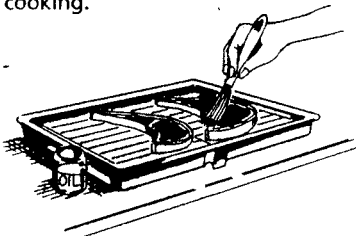

- ▼ Cook toast and rare steaks using the preheated full heat grill. All other foods cook very successfully on thermal grill.
- ▼ Place tomatoes and mushrooms on the grill pan beneath the grid when grilling meats.

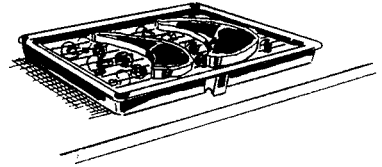

- ▼ If you use the thermal grill function to heat through ready prepared or cooked chilled dishes, e.g. shepherds pie, moussaka, lasagne, etc., ensure that they are piping hot throughout before serving.
- ▼ Be guided by the table on page 14.
- ▼ It is important not to grill with grill pan and grid in highest position.



## 1.1 USE OF THE GRILL

The conventional grill provides quick, direct heat. Dual circuit grills help to save energy. The whole area of the grill can be used as a high speed grill, or the centre section only for cooking smaller quantities.

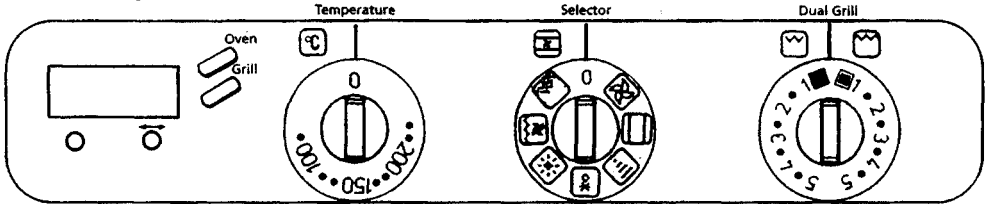

## 1.2 HOW TO SELECT THE GRILL

- 1 Ensure the oven temperature control is turned to '0'.
- 2 Turn the multifunction selector to grill.
- 3 Turn the grill control clockwise for full grill or anti-clockwise for the centre selection only. The selector surround will illuminate.

## 1.3 THINGS TO NOTE

- 1 The control cooling fan will operate in conjunction with the grill.
- 2 Always grill with the door fully open. The handle must be removed before grilling except when inserting or removing grill pan.
- 3 The grill indicator neon will come on and the grill control surround and selector surround will illuminate.

## 1.4 HINTS AND TIPS

(See 1.6 "Hints & Tips" on P12).

## GRILLING CHART

FOOD	SHELF	THERMAL GRILLING		FULL HEAT GRILLING	
		TEMPERATURE (°C)	GRILL TIME (MINUTES)	SETTING	GRILL TIME (MINUTES)
Bacon Rashers	4	200	8-12	Max.	2-3 each side
Beefburgers	4	190	10-15	Max	6-10 each side
Chicken joints	4	160	35-45	—	—
Chops – Lamb	4	170	20-25	—	—
Pork	4	170	25-30	—	—
Fish – Whole trout/cod	4	170	10-20	—	—
Fillets plaice/cod	3	170	10-15	—	—
Kebabs	4	170	20-30	—	—
Kidneys – Lamb/pig	4	180	10-15	—	—
Liver – Lamb/pig	4	180	20-30	—	—
Steaks – Rare	5	—	6-8 each side	Max.	—
Medium	5	220	8-10 each side	—	—
Well done	5	220	10-12 each side	—	—
Heating through & browning e.g. au gratin, lasagne, shepherds pie	4	170	20-30 depending on size	— —	— —
Browning only	3-5	—	—	—	—

**NOTE: Shelf positions are counted from the bottom of the oven.**

# 1. THE FAN OVEN

Follow the instructions below which are appropriate to your particular oven.

## 1.1 USES OF THE FAN OVEN

Due to the design the oven is heated by the element around the fan situated behind the back panel. The fan draws air from the oven, the element heats the air which is circulated into the oven via vents in the back panel. The advantages of cooking with this mode are:

### Preheating

The fan oven quickly reaches temperature, so it is not usually necessary to preheat the oven. Without pre-heating, however, you may find you need to add an extra 5-10 minutes on

the recommended cooking times. For recipes needing high temperatures e.g. bread, pastries, scones, souffles etc., best results are achieved if the oven is preheated first.

### Cooking Temperatures

Fan oven cooking generally requires lower temperatures than conventional cooking. Follow the temperatures recommended in the chart on page 36. As a guide reduce temperatures by about 20-25°C for your own recipes.

### Batch Baking

The fan oven cooks evenly on all shelf levels especially useful when batch baking.

## 1.2. SELECTING THE FAN OVEN (BS610 & BS620 Series)

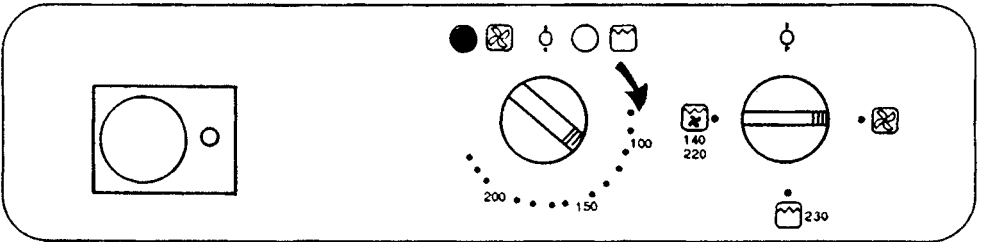
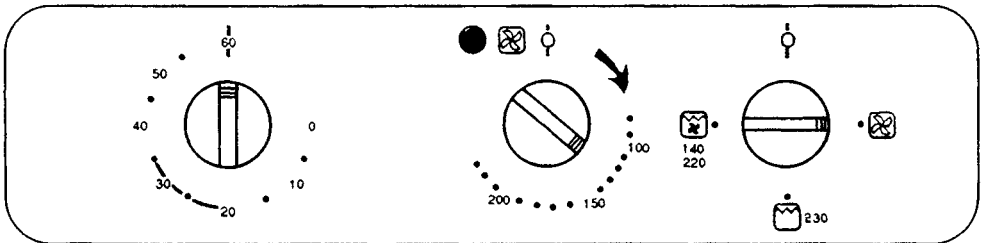

- 1 Turn the selector to fan oven.
- 2 Turn the oven temperature control to the required setting.

### NOTE:

- 1 The oven light will come on. (BS620 Series).
- 2 The oven indicator neon will glow.



## 1.2.2 SELECTING THE FAN OVEN (BS630 Series)

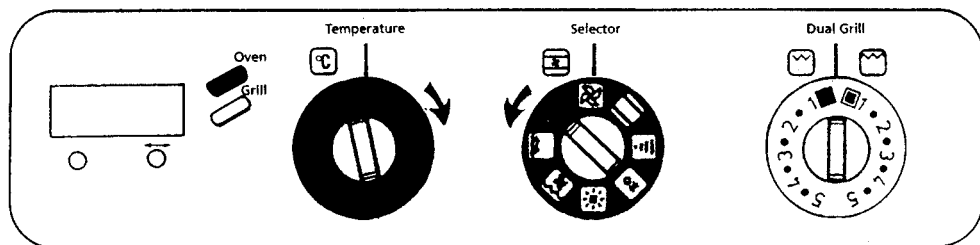

- 1 Turn the selector to fan oven.

### NOTE:

- 1 The multifunction selector and oven temperature control surrounds will illuminate.

- 2 Turn the oven temperature control to the required setting.

- 2 The oven light will come on.

- 3 The oven indicator neon will glow.

## 1.3 THINGS TO NOTE

- 1 The oven indicator neon will glow until the oven has reached the desired temperature, and then go off. It will cycle ON and OFF periodically during cooking showing that the temperature is being maintained.
- 2 The oven fan will operate continually during cooking.
- 3 The oven light (BS620 & BS630) operates when the selector is set. If an automatic programme is set, the oven light will come on when the cook time starts.
- 4 The control cooling fan will operate in conjunction with the fan oven.

## 1.4 HINTS AND TIPS

- ▼ When cooking more than one dish in the fan oven, place dishes centrally on different shelves rather than cluster several dishes on one shelf.
- ▼ When batch baking one type of food e.g. Victoria Sandwich cakes. Those of similar size will be cooked in the same time.

- ▼ It is possible to cook bulk loads on up to three shelves at any one time.
- ▼ It is recommended that when baking larger quantities, the shelf positions should be evenly spaced to suit the load being cooked. A slight increase in cooking time may be necessary.
- ▼ Do not place dishes directly on the oven floor as it interferes with the oven air circulation; use the lower shelf position.

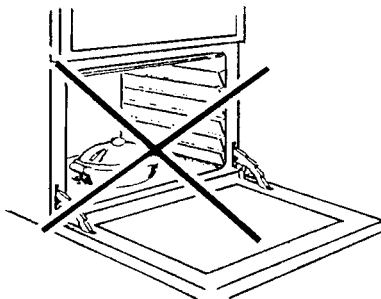

- ▼ The use of excessively high temperatures can cause uneven browning. It may be necessary to reduce temperatures slightly. Refer to the recommendations given in the oven cooking chart (See page 36).

## 2.1 USES OF DEFROST

This function defrosts most foods faster than more conventional methods. It is particularly suitable for delicate frozen foods which are to be served cold e.g. cream, gateaux, cakes covered with icings or frostings, cheesecakes, biscuits, scones etc.

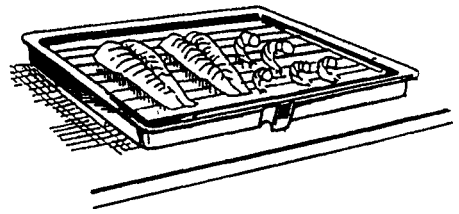
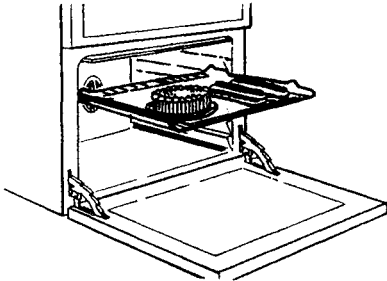

- ▼ It is preferable to thaw fish, meat and poultry slowly in the fridge. However this process can be accelerated by using the defrost function.
- ▼ Small or thin fish fillets, frozen peeled prawns, cubed or minced meat, liver, thin chops, steaks etc. can be thawed in 1-2 hours.

- ▼ A 1kg/2 1/4lb oven ready chicken will be thawed in approximately 5 hours. Remove the giblets as soon as possible during the thawing process.
- ▼ Joints of meat up to 2kg/4 1/2lb in weight can be thawed using the defrost function.

**ALL JOINTS OF MEAT AND POULTRY MUST BE THAWED THOROUGHLY BEFORE COOKING.**

**ALWAYS COOK THOROUGHLY IMMEDIATELY AFTER THAWING.**

### 2.2.1 SELECTING DEFROST (BS610 & BS620 Series)

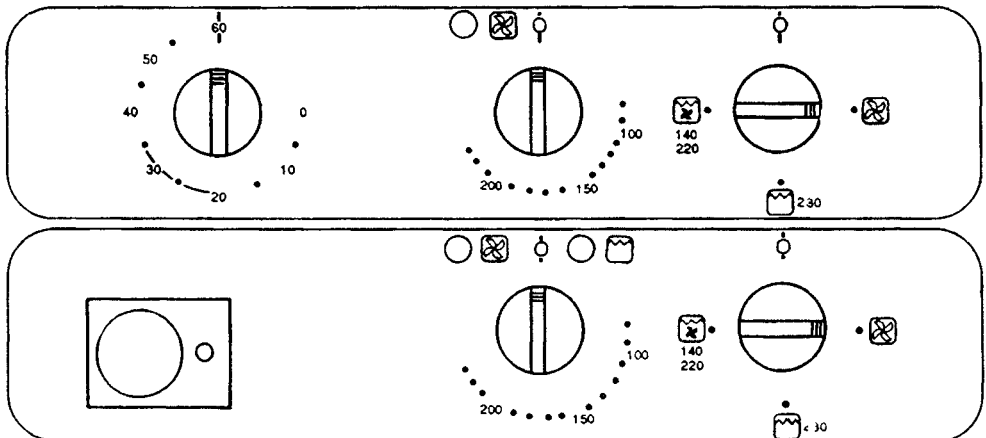

- 1 Turn the selector to fan oven.
- 2 Leave the temperature control off.

## 2.2.2 SELECTING DEFROST (BS630 Series)

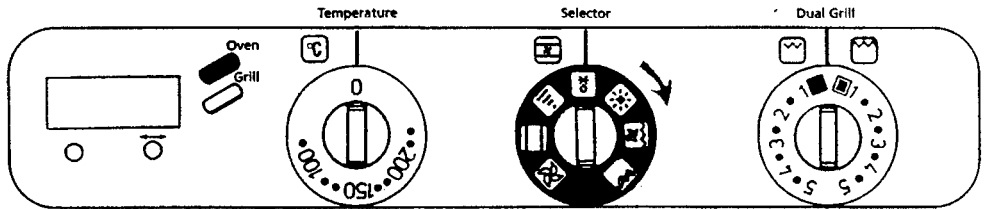

- 1 Turn the selector to Defrost.

### NOTE:

- 1 The multi function selector surround will illuminate.
- 2 The oven indicator neon will come on.

## 2.3 THINGS TO NOTE

- 1 No heat is produced when the defrost function is selected. The heating elements stay 'off' even if the oven temperature control is set. The cooling fan for the controls however will operate with the defrost function.
- 2 Care must always be taken when handling foods in the home. Always follow the basic rules of food hygiene to prevent bacterial and microbial growth and cross contamination when defrosting, preparing, cooking, cooling and freezing foods.

- 2 This function DOES NOT require a temperature setting on the oven temperature controller.

## 2.4 HINTS AND TIPS

- ▼ Place the frozen food in a single layer where possible, and turn it over half way through the defrosting process.

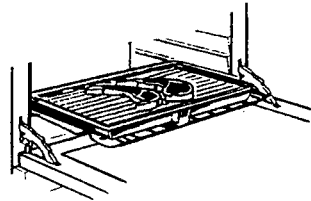

- ▼ The actual speed of defrosting is influenced by room temperature. On warm days defrosting will be faster than on cooler days.
- ▼ **Do not leave food at room temperature once it is defrosted. Cook raw food immediately or store cooked food in the fridge.**

## THE CONVENTIONAL OVEN

### 3.1 USES OF THE CONVENTIONAL OVEN

This function uses the top and lower elements to give single level cooking which is particularly suitable for dishes which require extra base browning such as pizzas, quiches and flans. Gratins, lasagnes and hotpots which require extra top browning also cook well in the conventional oven. This form of cooking gives you the opportunity to cook without the fan in operation.

### 3.2 SELECTING THE CONVENTIONAL OVEN

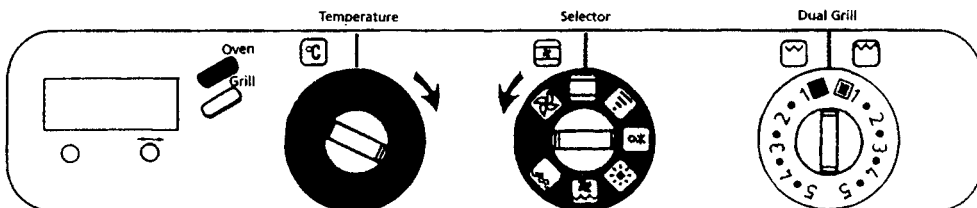

- 1 Turn the multifunction selector to conventional oven.
- 2 Turn the oven temperature control to the required setting.

#### NOTE:

- 1 The multifunction selector and oven temperature control surrounds will illuminate
- 2 The oven light will come on.
- 3 The oven indicator neon will glow.

### 3.3 THINGS TO NOTE

- 1 The oven indicator neon will glow until the oven has reached the desired temperature and then go 'off'. It will then cycle 'on' and 'off' showing that the oven temperature is being maintained.
- 2 The oven light operates when the selector is set. If an automatic programme is set the oven light will come on when the cook time starts.
- 3 The control cooling fan will operate in conjunction with the conventional oven.

### 3.4 HINTS AND TIPS

- ▼ The middle shelf position gives the best heat distribution. To increase base browning simply lower the shelf position to increase top browning, raise the shelf level.

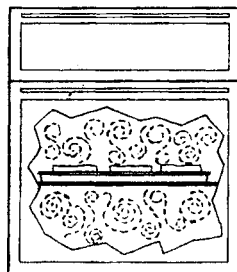

- ▼ In addition to the shelf position, the material and finish of the baking trays and dishes used will affect base browning. Enamel ware, dark, heavy or non-stick utensils increase base browning, while oven glass ware, shining aluminium or polished steel trays reflect the heat away and give less base browning.

- ▼ Always place dishes centrally on the shelf to ensure even browning.

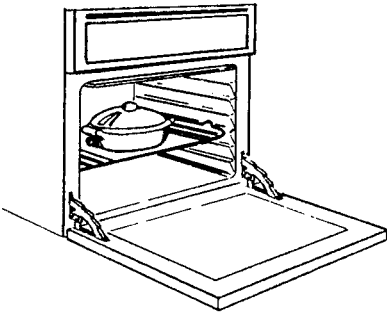

- ▼ Stand dishes on suitably sized baking trays to prevent spillage on the base of the oven and reduce cleaning.

- ▼ Do not place dishes directly on the oven base as it becomes very hot.

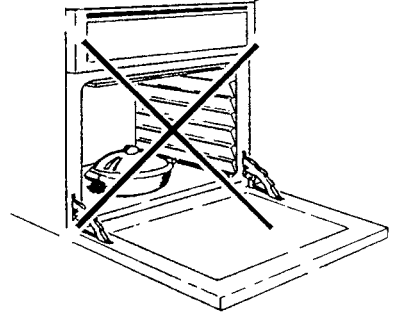

- ▼ For faster preheating use the fan oven function to preheat the oven until the oven indicator light goes out, then switch the selector to the conventional oven setting.

- ▼ Single level cooking gives best results. If you require more than one level cooking use the fan or zoned oven functions.

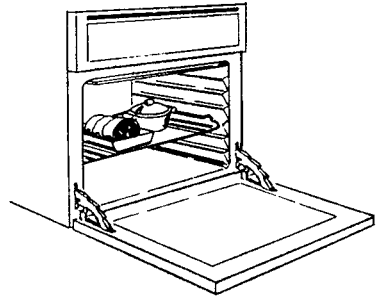



## 4.1 USES OF THE ZONED OVEN

Use the zoned oven when you require the oven to be hotter at the top than at the bottom. This gives the flexibility of cooking foods in the same oven at up to 30°C difference in cooking temperature.

The Zoned oven is useful for cooking dishes which require different temperatures in the oven at the same time and it is ideal for cooking a complete meal on two shelves.

## 4.2 SELECTING THE ZONED OVEN

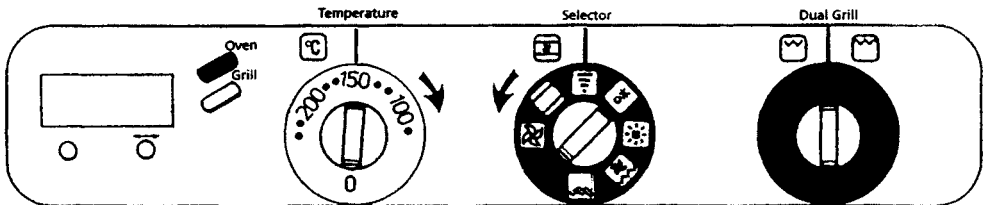

- 1 Turn the multifunction selector to Zoned oven.
- 2 Turn the oven temperature surrounds to the required setting.

### NOTE:

- 1 The multifunction selector and oven temperature surrounds will illuminate.
- 2 The oven light will come on.
- 3 The oven indicator neon will glow.

## 4.3 THINGS TO NOTE

- 1 If an automatic programme is set the oven light will come on when the cook time starts.
- 2 The oven indicator neon will glow until the oven has reached the desired temperature and then go 'off'. It will then cycle 'on' and 'off' showing that the oven temperature is being maintained.
- 3 The control cooling fan will operate in conjunction with the zoned oven.

## 4.4 HINTS AND TIPS

- ▼ Remember that the top of the oven is hotter than the bottom. The approximate difference in temperature between the top and the bottom is 30°C.
- ▼ If a higher shelf position is used than is recommended in the Chart (on page 36), it may be necessary to lower the cooking temperature by approximately 10°C.

- ▼ Be prepared to interchange dishes between the higher and lower shelf positions during cooking where necessary.

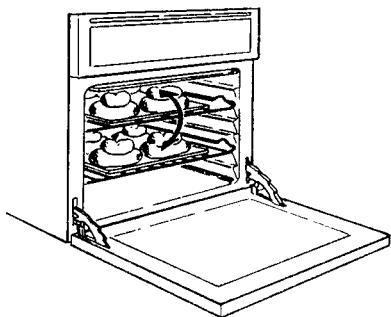

- ▼ Ensure that food is placed centrally on the shelves and that there is sufficient room around the dishes to allow for maximum air circulation.

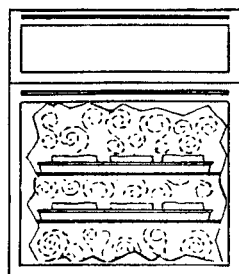

- ▼ It is best to cover dishes, where practical, for part of the cooking time to prevent over browning of the top surface. This also reduces fat splashes onto the oven interior and helps to keep the oven clean. Uncover for the last 15-30 minutes of cooking time and the food will be nicely browned.

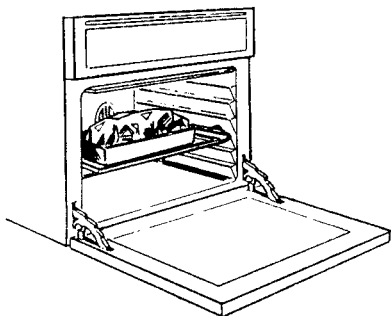

- ▼ The use of enamel ware or dark, heavy or non-stick utensils will help to increase base browning for dishes such as Yorkshire Pudding, Plate Pies etc.
- ▼ For faster preheating use the fan oven function to preheat the oven until the oven indicator light goes out, then switch to the zoned oven following the times, temperatures and shelf positions recommended.



## 5.1 USES OF THERMAL GRILLING

Thermal grilling offers an alternative method of cooking food items normally associated with conventional grilling.

The oven grill element and the fan operate together, circulating hot air around the food to assist the cooking process. The need to check and turn food is reduced. Thermal grilling helps to minimise cooking smells in the kitchen and allows you to grill with the oven door closed.

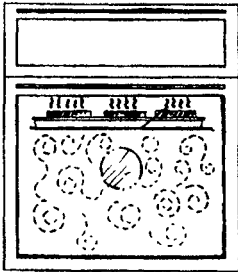

With the exception of toast and rare steaks, you can thermal grill all the foods you would normally cook under a conventional grill.

The lower part of the oven can be used to cook accompaniments at the same time e.g. bacon rolls with a mixed grill or breakfast.

Dishes prepared in advance such as shepherd's pie, lasagne and au gratins can be heated through and browned on the top using the thermal grilling function.



## 5.2 SELECTING THERMAL GRILLING (BS630 Series only)

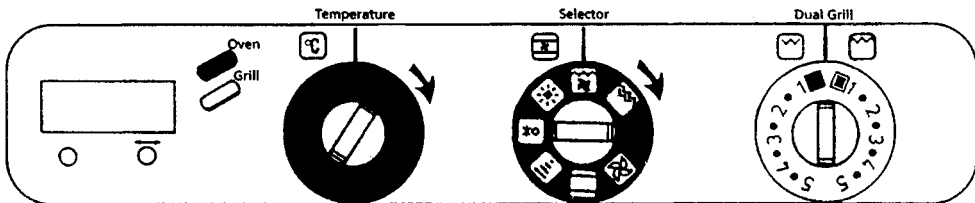

- 1 Turn the multifunction selector to Thermal Grilling.
- 2 Turn the oven temperature control to the required setting (A temperature of between 140°C and 220°C is suitable for thermal grilling).

### NOTE:

- 1 Thermal grilling helps to minimise cooking smells in the kitchen and is carried out with the main oven door closed.
- 2 Always thermal grill with door closed and grill pan handle removed.

## 5.3 THINGS TO NOTE

- 1 The oven indicator neon will glow until the oven has reached the desired temperature and then go 'off'. It will then cycle 'on' and 'off' showing that the oven temperature is being maintained.
- 2 The multifunction selector and oven temperature control surrounds will illuminate.
- 3 The oven fan and light will come on. If an automatic programme is set the oven light will come on when the cook time starts.
- 4 The control cooling fan will operate in conjunction with the thermal grilling function.

## 5.4 HINTS AND TIPS

- ▼ Prepare foods in the same way as for conventional grilling. Brush lean meats and fish lightly with a little oil or butter to keep them moist during cooking.

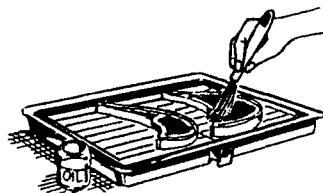

- ▼ Most foods should be placed on the grill pan grid in the 'high' position in the grill pan to allow maximum circulation of air around the food. Foods such as fish, liver and kidneys may be placed directly onto the trivet in the grill pan, if preferred.

- ▼ The use of the trivet beneath the grid when grilling fatty foods will help to minimise fat splashing.

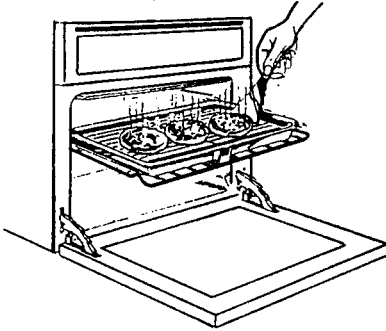

- ▼ Accompaniments such as tomatoes and mushrooms may be placed below the grid when grilling meats, or in a separate dish on a lower shelf.

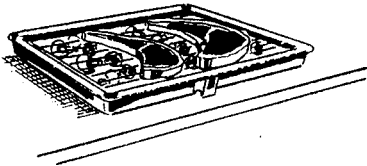

- ▼ Foods will cook more quickly the closer they are to the grill element and the higher the temperatures selected. Be prepared to adjust temperature and shelf positions during cooking, if necessary.
- ▼ Turn foods over during the cooking time, as necessary.

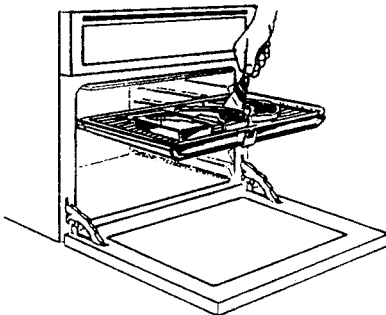

- ▼ **ENSURE THAT READY PREPARED OR COOKED CHILLED DISHES E.G. SHEPHERDS PIE, MOUSSAKA, LASAGNE ETC., ARE PIPING HOT THROUGHOUT, BEFORE SERVING.**

A temperature range of 140 – 220°C and shelf positions 3 and 4 are suitable for most foods. Be prepared to make adjustments during cooking to suit individual requirements. If thermal grilling on more than one level, it may be necessary to interchange the food on the shelves during cooking.

## COOKING TIMES

Cooking is more gentle, therefore food generally takes a little longer to cook when thermal grilling compared with conventional grilling. One of the advantages is that larger loads can be cooked at the same time.

A general guide to cooking times is given on page 14 but these times may vary slightly depending on the thickness and quantity of the food being cooked.



## 6.1 USES OF OVEN CLEAN

When oven clean is selected the Stayclean surfaces inside the oven burn off any splashes of fat and food.

By using this function regularly the Stayclean finishes remain in good condition and do not require manual cleaning. This saves time and effort in keeping the oven clean. (See Care and Cleaning Section on Page 38 for instructions on cleaning the Vitreous enamel oven base).

## 6.2 SELECTING OVEN CLEAN

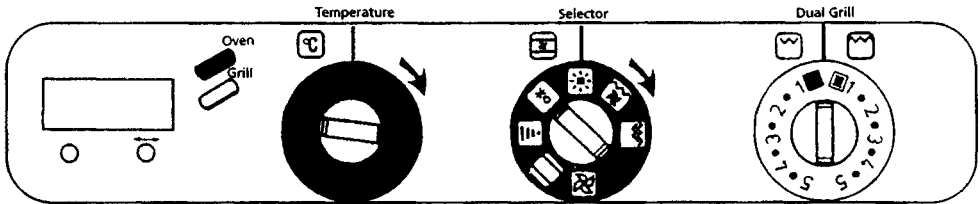

- 1 Remove Oven shelves and bakeware from oven.
- 2 Turn the multifunction selector to oven clean.
- 3 Set the oven temperature to maximum.

## 6.3 THINGS TO NOTE

- 1 The oven indicator neon will glow until the oven has reached the desired temperature and then go 'off'. It will then cycle 'on' and 'off' showing that the oven temperature is being maintained.
- 2 The multifunction selector and oven temperature control surround will illuminate.
- 3 The oven light operates when the selector is set. If an automatic programme is set the oven light will come on when the cook time starts.
- 4 The control cooling fan will operate in conjunction with the oven clean function.

## 6.4 HINTS AND TIPS

- ▼ Manual cleaning of the Stayclean surfaces is not recommended. **Damage will occur if soap impregnated steel wool pads, aerosol cleaners, or any abrasive cleaners are used.**

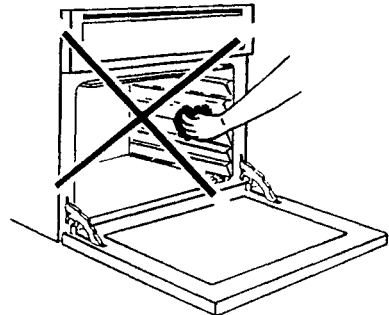

- ▼ Slight discolouration and polishing of the Stayclean surfaces may occur in time, but this will not affect their self cleaning properties.
- ▼ Surfaces which are not Stayclean coated e.g. the oven base, the oven exterior etc. will require manual cleaning. Refer to the Care and Cleaning section page 38 for details.

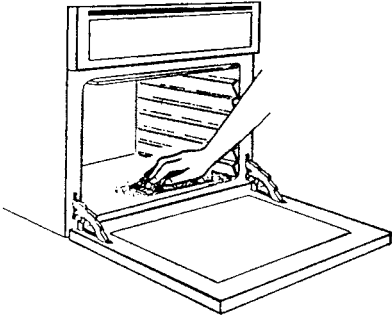

- ▼ Use the oven clean function for an hour or two per week to avoid a build up of soilage which could prevent the stayclean enamel from working properly.

- ▼ A good time to use the oven clean function is after the weekly roast. Simply select oven clean function as described above and allow the oven to run for an hour or so.

**IF YOU HAVE AN EXCESSIVE SPILLOVER ONTO THE STAYCLEAN ENAMEL YOU MAY MANUALLY CLEAN IF NECESSARY. TAKE CARE NOT TO SCRAPE ENAMEL.**

- ▼ Useful hints and tips are given on page 41 on how to adjust your cooking to keep oven soilage to a minimum.

## HOW TO USE YOUR MINUTE MINDER (Model BS610 only)

A period of up to 60 minutes can be timed using the minute minder. At the end of the set time a bell will ring for approximately 5 seconds and the control knob will return to the position shown.

### TO SET THE MINUTE MINDER (for intervals up to 15 minutes)

- 1 Turn the control knob clockwise, past the interval you want to be timed (at least as far as 20 minutes).
- 2 Turn the control anti-clockwise back to the required interval to be timed.

By setting the timer like this, greater accuracy is achieved.

- 3 The minute minder offers an audible reminder of time, it does not affect the operation of the oven.

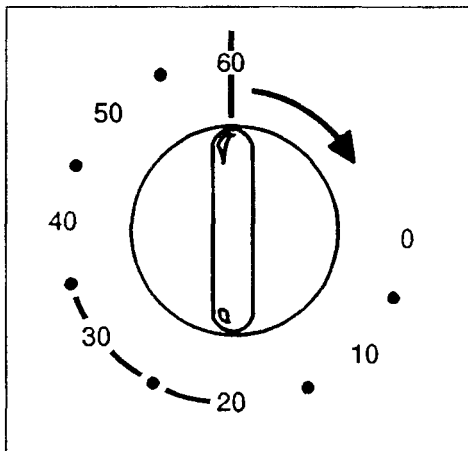

## 1 HOW TO USE YOUR TIMER (BS620 Series)

- A** Inner section of control knob.
- B** Outer section of control knob.
- 1** Hand for minute minder.
- 2** Off position for minute minder.
- 3** Start time indicator line.
- 4** Stop time indicator.
- 5** Cook time.
- 6** Area indicating completion of automatic programme. When only this area is visible return cooker to manual (see page 31).
- 7** Dot indicator.

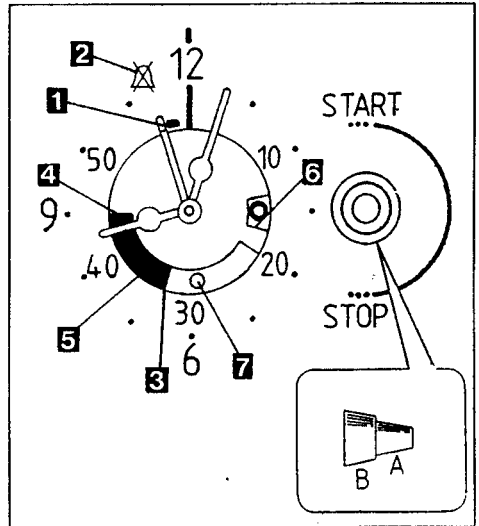

## 2 TO SET THE TIME OF DAY

Push in and turn the inner section of the control knob (A) in either direction until the correct time of day is shown. The clock will operate when the cooker is switched on at the wall.

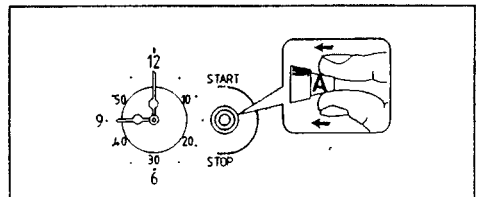

## 3 TO SET THE MINUTE MINDER

Use the control knob (A). Without pushing it in, turn the knob in either direction. A period of up to 55 minutes can be timed using the minute minder. At the end of the set time a bell will ring.

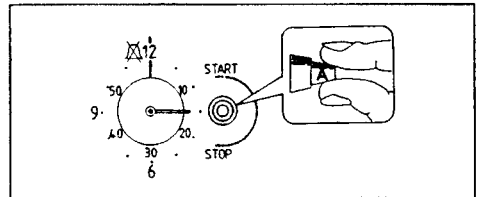

### 3.1 TO CANCEL THE MINUTE MINDER

Use the control knob (A). Without pushing it in, turn the knob in either direction until the hand for the minute minder points to ~~X~~.

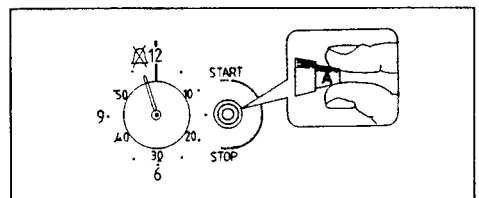

## 4 HOW TO SET THE OVEN TIMER CONTROL:-

- A** To switch the oven on and off automatically.
- 1 Make sure the electricity supply is switched ON. Set the correct time of day (e.g. 9a.m.).
  - 2 Place food in oven.
  - 3 Turn the outer section of the control knob (B) clockwise until the stop time indicator line (5) lines up with the time you want the food to be ready e.g. 6p.m.
  - 4 Turn the outer section of the control knob (B) anticlockwise until the start time indicator line (4) lines up with the time you want the food to start cooking e.g. 4p.m.
  - 5 Turn the oven temperature control to the required setting. The oven indicator light should be 'off'.
  - 6 When automatic cooking starts the oven thermostat light will cycle 'on' and 'off' as usual. The area indicating cook time will gradually decrease until the stop time is reached.
- B** To start cooking now, then switch off automatically.

- 1 Follow points 1-3 above.
- 2 Turn the outer section of the control knob anti-clockwise until the start time indicator line is exactly in line with the hour hand of the clock, e.g. 4p.m.
- 3 Turn the oven temperature to the required setting (if the oven is not already on).
- 4 The cook time area will gradually decrease until the stop time is reached.

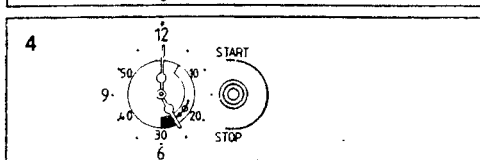
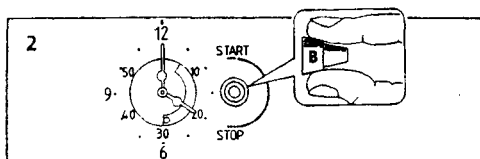
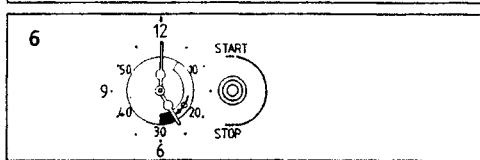
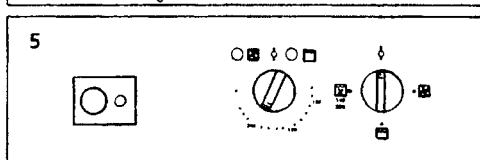
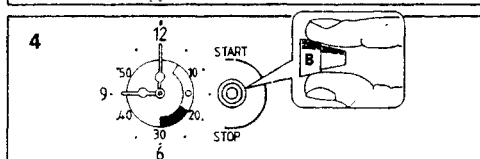
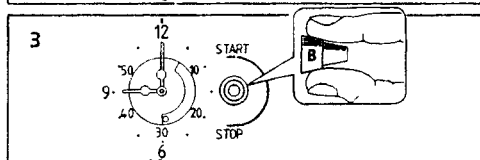
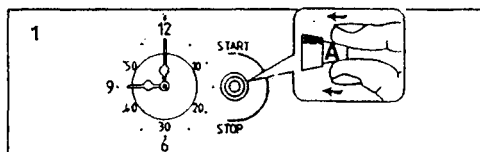

## 5 TO RETURN THE COOKER TO MANUAL OPERATION

To cancel an Automatic programme or return the cooker to manual follow the steps given below otherwise the cooker will not operate manually.

- 1 At the end of the timed cooking period only the '0' will be visible on the clock. Turn the outer section of the control knob clockwise until the  symbol appears in the box.
- 2 Turn the oven temperature control on to check that the oven operates manually. The oven indicator light should come on.
- 3 Turn the oven control off.

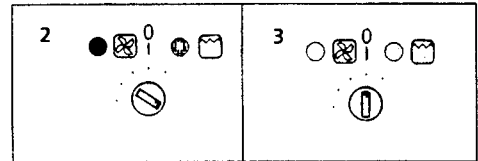
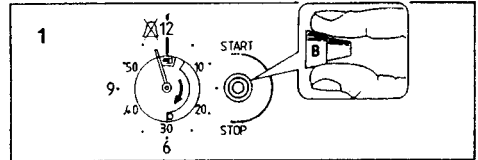

## 6 THINGS TO NOTE

- 1 When an automatic programme has been set on the oven the grill can be selected for manual operation. Remember to return the cooker to the required cooking mode upon completion of grilling.
- 2 The maximum cooking time on automatic is 3½ hours.
- 3 The delay time plus the cooking time must not exceed 12 hours.
- 4 The automatic timer control and minute minder operate within limits which ensure good cooking results. There may, however be slight variations in the set cooking period. The electric clock keeps accurate time.



# 1 HOW TO USE YOUR TIMER (BS630 Series)

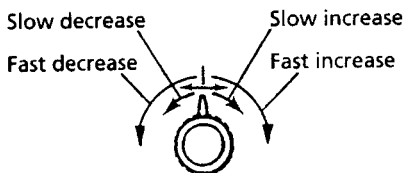

## KEY OF SYMBOLS ON TIMER

Time of Day: ☐

Minute Minder: 🔔

Cooking Symbol 🔥

Automatic Setting: A  
U  
O

Count Down/Up: ↔

# 2 NOTE: THE FOLLOWING STEPS MUST BE FOLLOWED BEFORE THE COOKER WILL OPERATE MANUALLY.

## TO SET THE TIME OF DAY

- 1 Turn the selector to clock ☐  
Turn the setting knob until the correct time of day is shown e.g. 1 p.m.  
The timer will stop flashing.
- 2 Set the selector to manual. the cooking symbol will illuminate. 🔥

The oven can now be operated manually. The clock will show the time of day as long as the oven is switched on at the wall. The above steps must be followed every time the oven is switched off at the wall or if there has been a power failure.

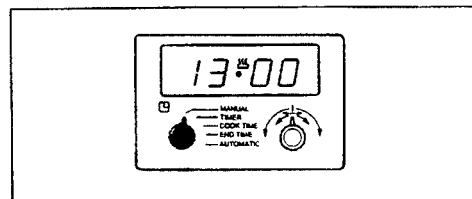
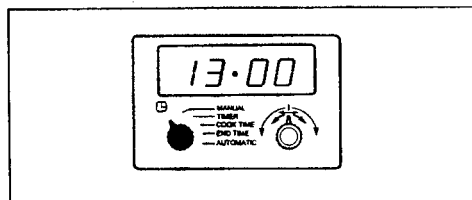
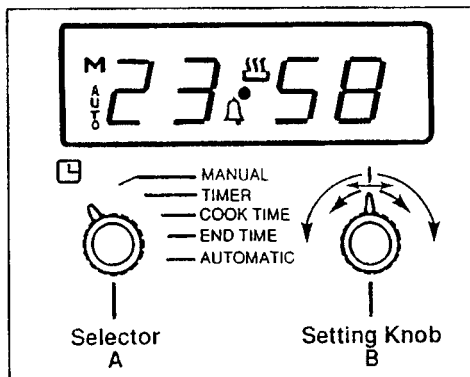

### 3 TO SET THE MINUTE MINDER

- 1 Turn the selector to timer.
- 2 Turn the setting knob until the required period to be timed is shown e.g. 40 mins.
- 3 Return the selector to manual setting. The minute minder symbol  will illuminate.

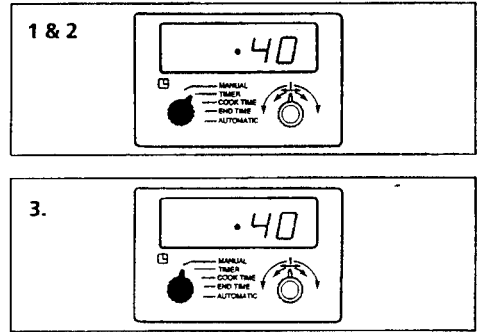

At the end of the timed interval an audible signal will sound. To cancel the signal:

- 1 Turn the selector to any other setting.
- 2 Return the selector to Manual setting. The minute minder symbol will go out. If the signal is not cancelled the timer will ring for a period of 7 minutes then automatically stop.

### TO CANCEL THE MINUTE MINDER

- 1 Turn the selector to timer.
- 2 Turn the setting knob until the display shows 00.00. The minute minder symbol will go out.
- 3 Return the selector to manual setting.

### THINGS TO NOTE

- 1 The minutes remaining on the timer can be checked at any time by turning the selector to timer.
- 2 A period of up to 23 hrs. 59 mins. can be timed.

### 4 HOW TO SET THE OVEN TIMER CONTROL

- A To switch the oven(s) On and Off automatically.
- 1 Make sure the electricity supply is switched on. Set the correct time of day e.g. 9 a.m.
  - 2 Place food in oven.

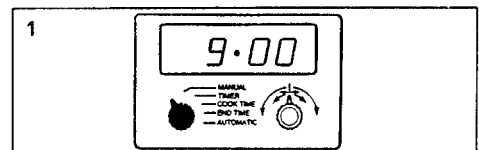

- 3 Turn the selector to 'cook time'. Using the setting knob, set the required number of cooking hours and minutes e.g. 2 hrs. 30 mins. The AUTO display and cooking symbol will illuminate.
- 4 Turn the selector to 'End time'. Using the setting knob. Set the time you want the food to be ready e.g. 6 p.m. The cooking symbol will go out.
- 5 Turn the selector to 'Automatic'. The display returns to show the time of day after a few seconds.
- 6 Set the oven temperature (if the oven is not already on).
- B** To start cooking now, then switch off automatically.
- 1 Follow points 1-3 from page 33, section 4.
- 2 Turn the selector to 'Automatic'. The display will return to show the time of day e.g. 3 p.m. after a few seconds.
- 3 Set the oven temperature (if the oven is not already on).

## THINGS TO NOTE

- 1 The automatic timer will calculate what time to switch off.
- 2 The 'end time' can be checked by turning the selector to end time.

## 6 TO CANCEL AN AUTOMATIC PROGRAMME AND/OR RETURN TO MANUAL OPERATION.

- 1 Simply set the selector to manual. The AUTO display will stop flashing and go out. The cooking symbol will light.
- 2 Set the oven temperature to 0.

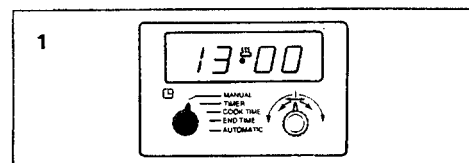
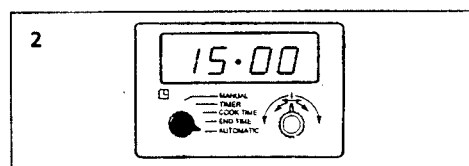
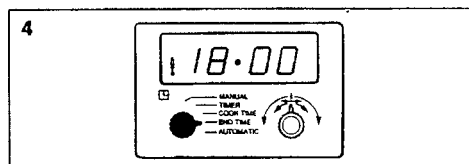
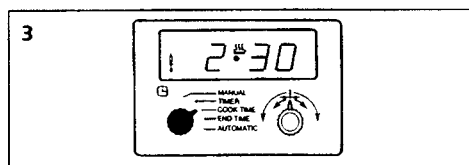

## THINGS TO NOTE

- 1 The 'cooking' symbol  will illuminate when the cook time starts.
- 2 At the end of an automatic programme the cooking symbol will go out and an audible signal will sound (for up to 7 minutes).  
The 'AUTO' display will flash. To stop the flashing, turn the selector to manual.
- 3 To check the time remaining in an automatic programme, turn the selector to cook time.  
**DO NOT TURN TO MANUAL**, as this will cancel the automatic programme.
- 4 If AUTO display flashes when an automatic programme has been set, an error in setting has been made.  
Check that you have not tried to set an 'impossible' setting.
- 5 On multifunction ovens (BS630 Series), it is possible to cook automatically on all cooking functions except conventional grilling which must always be carried out manually.

## 1 OVEN COOKING CHART

The oven temperatures are intended as a guide only. It may be necessary to increase or decrease the temperature by 10°C to suit individual preferences and requirements.

Note: Shelf positions are counted from the bottom of the oven.

FOOD	FAN OVEN		ZONED OVEN		CONVENTIONAL OVEN	
	SHELF POSITIONS	COOKING TEMP°C	SHELF POSITIONS	COOKING TEMP°C	SHELF POSITIONS	COOKING TEMP°C
Biscuits		180-190	2 & 4	160 - 170	3	180 - 190
Bread	Shelf positions are not critical but ensure that oven shelves are evenly spaced when more than one is used.	210-220	3	200 - 210	3	210 - 220
Casseroles		130-140	3	160 - 170	3	170 - 180
Cakes:		160-170	2 & 4	160 - 170	3	170 - 180
Small and Queen Sponges		160-170	2 & 4	160 - 170	3	180 - 190
Madeira		140-150	3	140 - 150	3	160 - 170
Rich Fruit		130-140	2	130 - 140	3	150 - 160
Christmas		130-140	—	—	2	130 - 140
Meringues		90-100	2 & 4	90 - 100	3	100 - 110
Fish		170-190	2 & 4	160 - 180	3	170 - 190
Fruit Pies and Crumbles		190-200	3	160 - 170	3	180 - 190
Milk Puddings		140-150	3	170 - 180	3	200 - 210
Pastry:			3	130 - 140	3	140 - 150
Choux			2 & 5	160 - 170	3	190 - 200
Shortcrust						
Flaky						
Puff						
Plate Tarts		180	2 & 5	160 - 170	3	200 - 210
Quiches/Flans		180	2 & 5	170 - 180	3	200 - 210
Scones		220-230	2 & 5	210 - 220	3	230 - 240
Roasting:		170-180	2	170 - 180	2	180 - 190
Meat and Poultry						

Care must be taken when handling foods in the home. Always follow the basic rules of food hygiene to prevent bacterial and microbial growth and cross contamination when preparing, re-heating, cooking, cooling, defrosting and freezing foods:-

- 1 Always ensure food you purchase is of good quality and in prime condition. Shop at a reliable source and buy the 'freshest' looking package – avoid shopworn labels or produce covered in dust.
- 2 Avoid buying chilled or frozen foods if you cannot store them straight away. The use of an insulated container when shopping is advisable.
- 3 Buy and consume foods prior to the 'Sell By' or 'Best Before' date.
- 4 When you arrive home, place perishable foods in the refrigerator or freezer immediately. Ensure they are well covered to prevent them drying out and to prevent any possible cross contamination with bacteria from raw to cooked foods.
- 5 Follow the cooking instructions on packets of pre-prepared and cook chill foods but be prepared to adjust cooking times and temperatures to suit your particular oven. For example, the Fan Oven generally requires 20-25°C lower temperature than the conventional oven mode.
- 6 Always ensure that cook chill foods are thoroughly re-heated until they are piping hot throughout.
- 7 It is preferable to defrost frozen foods slowly in the refrigerator. Alternatively, a microwave cooker or the Defrost function on your oven may be used.

- 8 Always cook defrosted food immediately after thawing. Thawed food should never be refrozen.
- 9 Joints of meat and poultry should be thoroughly defrosted before cooking.
- 10 Cook meat thoroughly – use a meat thermometer if preferred, which penetrates the joint to check that the centre temperature has reached the required temperature (see Table below).

MEAT	TEMPERATURES
BEEF	Rare – 60°C Medium – 70°C Well Done – 80°C
PORK	Well Done – 80°C
LAMB	Medium – 70°C Well Done – 80°C

- 11 If not eaten straight away after cooking, food should be cooled as quickly as possible (within one hour) and then refrigerated or frozen as required. (Do not put hot food into a Refrigerator or Freezer).
- 12 In the kitchen keep worktops, chopping boards and utensils clean with hot soapy water between preparation stages. Ideally, keep one chopping board for raw meats and another for other foods. Keep your dishcloths and tea towels clean.

# 1 CARE AND CLEANING

ALWAYS SWITCH OFF THE ELECTRICITY SUPPLY BEFORE CLEANING

The oven door is removable to aid cleaning.

The cavity door seal is not removable for cleaning.

## 1.1 CLEANING MATERIALS

Before using any cleaning materials on your oven, check that they are suitable and that their use is recommended by the manufacturer.

Cleaners which contain bleach should not be used as they may dull the surface finish. Harsh abrasives should also be avoided.

## 1.2 CLEANING THE OUTSIDE OF THE OVEN

The control panel and oven door areas should be regularly wiped over using a soft cloth well wrung out in warm water to which a little liquid detergent has been added.

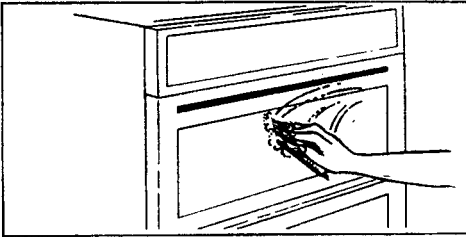

Do not attempt to remove any of the control knobs from the panel as this may cause damage and produce a safety hazard.

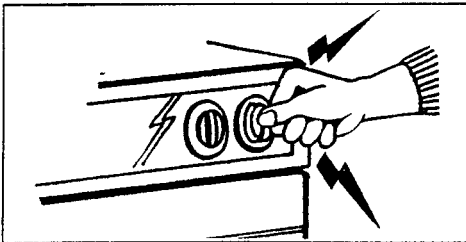

## 1.3 CLEANING THE OVEN DOOR

The oven door is removable to aid access to the oven for cleaning.

### 1.3.1 TO REMOVE THE DOOR

- 1 Fully open door.

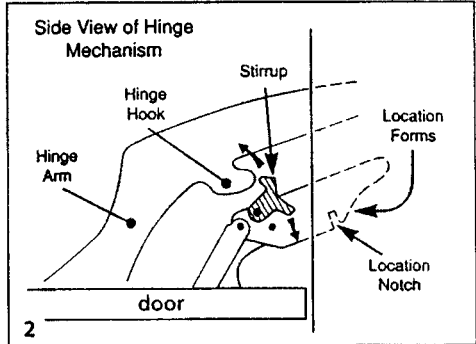

- 2 Each door hinge is fitted with a pivoting stirrup. These must be rotated forward to locate into the hinge hook in each hinge arm to facilitate removal of the door.

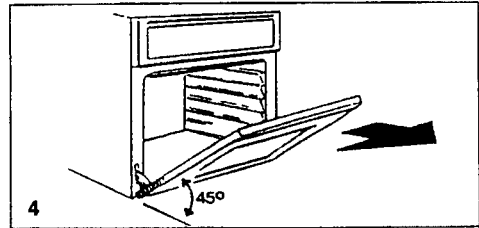

- 3 While holding the stirrups in the hinge hooks slightly close the door until the stirrups are held in position by the door closing force.
- 4 Continue to close the door until it is at an angle of 45° to the horizontal. When at this position slightly lift door, to disengage location notches then pull the door towards yourself. This will cause the hinges to disengage from the cooker and the door may be lifted free.

- 5 To replace the door, hold it in the same orientation as in diagram 4, slide both hinge arms into the holes on the hinge location forms until the location notches are engaged into the bottom inner edge of the holes.  
Tilt the door to the fully open position and this will cause the stirrups to disengage from the hinge hooks and allow the door to be closed.

### 1.3.2 CLEANING INSIDE THE OVEN DOOR

The glass panel on the inside of the oven door is removable for easy cleaning.

- 1 Remove the door (see opposite) or open it fully.
- 2 Use a pozidrive screwdriver to remove the screws holding the trim. Lift off the trim.

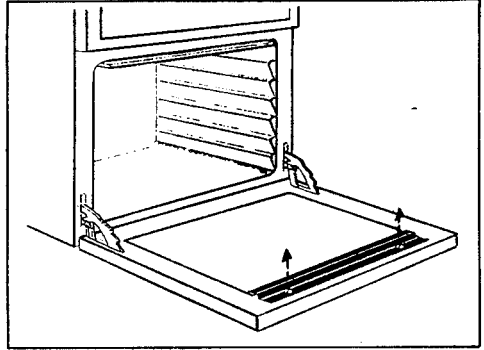

- 3 Carefully lift out the inner door glass, taking care not to damage it or displace the seals from the door frame.

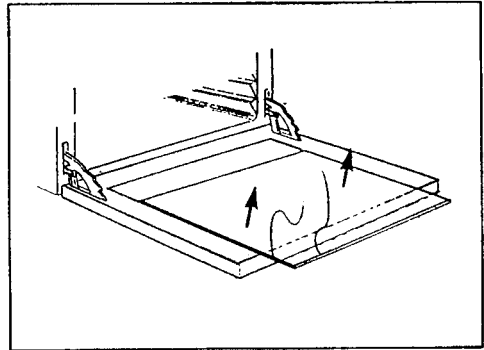



- 4 Clean the glass using warm water to which a little detergent has been added. Burned on soilage can be removed by using a mild abrasive as necessary. Dry thoroughly.

- 5 Replace the glass by carefully placing it through the side channels into the bottom trim. Make sure the glass is facing the correct way by following the message on the glass.

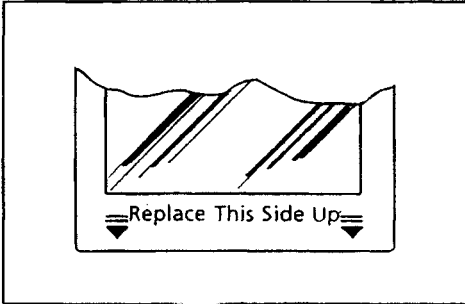

- 6 Replace the top trim so that the seal fits snugly over the top edge of the glass. Replace the trim.

- 7 Fasten the top door trim back into position.

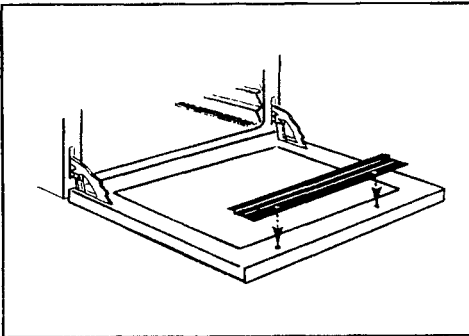

**WARNING: DO NOT RUN THE OVEN WITHOUT THE INNER DOOR GLASS FITTED. ENSURE BOTTOM GLASS SEAL IS CORRECTLY IN POSITION.**

## 1.4 CLEANING INSIDE THE OVEN

The Stayclean surfaces inside the oven should not be cleaned manually. See page 41... Care of Stayclean Surfaces. The vitreous enamel oven base can be cleaned using normal oven cleaners or aerosol oven cleaners with care. Ensure that the manufacturers instructions are followed and that all parts are well rinsed afterwards.

**AEROSOL CLEANERS MUST NOT BE USED ON STAYCLEAN SURFACES AND MUST NOT COME INTO CONTACT WITH ELEMENTS AS THIS MAY CAUSE DAMAGE.**

The roof panel/grill deflector is removable for easy cleaning. Thorough cleaning with a soap impregnated steel wool is recommended.

## 1.5 CLEANING THE OVEN SHELVES AND GRILL PAN

All removable parts are dishwasherable. Alternatively, soak them in hot soapy water if they are heavily soiled. They will then clean more easily.

The grill pan, meat tin and trivet can be cleaned using a soap impregnated steel wool pad. The grill pan grid should be cleaned in hot soapy water.

## CARE OF STAYCLEAN SURFACES

Stayclean surfaces destroy splashes of food and fats when the oven temperature is raised to around 230°C. To aid this process it is a good idea to run the oven for an hour or two per week, without food to ensure continued good performance from the Stayclean finish.

## 2 HINTS AND TIPS

- ▼ Manual cleaning is not recommended. Damage will occur if soap impregnated steel wool pads, aerosol cleaners and any other abrasives are used.
- ▼ Slight discolouration and polishing of the Stayclean surface may occur in time, but this does not effect the Stayclean properties in any way.
- ▼ A good time to allow the oven to run on is after the weekly roast. After removing the roast turn the oven up to 230°C and allow to run for an hour or so. It is important to not allow a build up of soilage as this can prevent the Stayclean finish from working.

- ▼ Follow the recommendations below to keep oven soilage to a minimum.

## 3 COOKING TO REDUCE SOILAGE

- 1 Cook at the recommended temperatures. Higher temperatures during roasting will increase soilage. Try cooking at lower temperatures for an increased length of time, you will save energy and often the joint is more tender.
- 2 Use minimal, if any, extra oil or fat when roasting meat; potatoes only require brushing with fat before cooking. Extra fat in the oven during roasting will increase splashing and soilage.
- 3 It is not necessary to add water to the meat tin when roasting. The water and the fat juices from the joint create excessive splattering during cooking – even at normal temperatures as well as causing condensation.
- 4 Covering joints during cooking will also prevent splashings onto the interior surfaces; removing the covering for the last 20-30 minutes will allow extra browning if required. Some large joints and turkeys especially will benefit by this method of cooking, allowing the joint to cook through before the outside is over-browned.
- 5 Do use (BS630 Series) the trivet in the roasting tin. During roasting, the fat from the joint will be contained beneath the trivet and therefore prevent it from splattering onto the 'Stayclean' finish.

We strongly recommend that you carry out the following checks on your appliance before calling a Service Engineer. It may be that the problem is a simple one, which you can solve yourself without the expense of a Service call. If our Service Engineer finds that the problem is listed below you will be charged for the call whether or not the appliance is under guarantee.

## ALL MODELS

### Problem:

*The grill, oven and timer do not work.*

### Solution:

- i) Check that the appliance has been wired in.
- ii) Check that the appliance is switched on at the wall.
- iii) Check that the main cooker fuse is working.
- iv) Check that the timer is set to manual. See page 31 or 34.

If you have checked the above:

- v) Switch off appliance at the wall and allow the appliance to cool for a couple of hours. Switch on again and check that the appliance is now working normally.

### Problem:

*The grill works but the main oven does not.*

### Solution:

#### Models: BS620 Series

- i) Check that the timer is set for manual operation. See page 31.
- ii) Check that the grill control is in the 'off' position.

#### Models: BS630 Series

- i) Check that the timer for the oven is set for manual. See page 34.
- ii) If you have checked (i) switch off at the wall to allow oven to cool. Check that the oven is now working normally.

### Problem:

*The timer control does not work.*

### Solution:

- i) Check that the timer operating instructions are being closely followed.

### Problem:

*The grill does not work or cuts out after being used for a long period of time.*

### Solution:

- i) Leave the oven to cool for a couple of hours. Check that the grill is now operating normally. Ensure that the door is left open during grilling.

### Problem:

*The oven temperature is too high or too low.*

### Solution:

- i) Check that the recommended temperatures are being used. See page 36. Be prepared to adjust up or down by 10°C to achieve the results you want.
- ii) Care should be taken when using your oven thermometer to check oven temperatures as they may be inaccurate.

The following factors should be considered:

- a) Ensure you purchase an accurate good quality instrument.
- b) Ovens will cycle about a set temperature and will not be constant.

**Problem:**

*The oven is not cooking evenly.*

**Solution:**

- i) Check that the appliance is correctly installed and that it is level.
- ii) Check that the recommended, temperatures and shelf positions are being used.

**Problem:**

*The oven light fails to illuminate.*

**Solution:**

- i) Request a service engineer to replace the faulty bulb.

**Problem:**

*The oven fan is noisy.*

**Solution:**

- i) Check that the oven is level.
- ii) Check that bakeware and shelves are not vibrating in contact with the back panel in the oven.

**MULTIFUNCTION MODELS (BS630 Series)**

**Problem:**

*The indicator neons are not working correctly or the function selected is not working.*

**Solution:**

- i) Check that you have correctly selected only the oven function you require. Ensure all other controls are in the off '0' position.

## **1. HELP US TO HELP YOU**

Please determine your type of enquiry before writing or telephoning.

### **1 SERVICE**

In the event of your appliance requiring service Tricity Bendix Limited have an arrangement with Electrolux Group Service.

Before calling out an Engineer, please ensure you have read the details under the heading "Something Not Working?" and have the model number and purchase date to hand. The telephone number and address for service is detailed on the list headed "Customer Service Centres".

**PLEASE NOTE** that all enquiries concerning service should be addressed to your local Customer Service Centre.

### **2 CUSTOMER RELATIONS DEPARTMENT**

FOR GENERAL ENQUIRIES concerning your Tricity Bendix cooker, or further information on Cookers, Microwaves, Refrigeration or Home Laundry equipment, you are invited to contact our Customer Relations Department, by letter or telephone as follows:-

**Tricity Customer Relations Department,  
Tricity Bendix Limited,  
55-59 High Street,  
Broxbourne,  
Hertfordshire,  
EN10 7HJ.  
Tel: (0992) 469080**

### **3 Rating Plate**

The rating plate can be seen along the bottom trim by opening the oven door. It gives the **MODEL AND SERIAL NUMBER**, which should be quoted in any communications.

It is advisable to make a note on the back cover of this book for easy reference.

## 2. CUSTOMER SERVICE CENTRES

The Electricity Boards are responsible for the servicing of cookers sold by their own outlets. The telephone numbers can be found in the telephone directory.

Service for cookers bought from other outlets can be obtained by calling the nearest Customer Service Centre on the numbers given below. The areas are defined by Postcode for easy reference.

<b>ABERDEEN</b> DD, IV, KW, AB, PH	<b>(0224) 696569</b>	Tricity Bendix Service 8 Cornhill Arcade, Cornhill Drive, Aberdeen AB2 5UT.
<b>ALTHAM - MANCHESTER</b> SK, M, BL, OL, BB	<b>(0282) 74621/ 2/3/4</b>	Tricity Bendix Service P.O. Box 19, Altham Lane, Altham, Accrington, Lancs. BB5 5XY.
<b>BELFAST</b> BT	<b>(0232) 746591</b>	Tricity Bendix Service Unit C3, Edenderry Industrial Estate, 326 Crumlin Road, Belfast BT14 7EE.
<b>BIRMINGHAM</b> WR, DY, B, WV, TF, ST, WS, SY	<b>(021) 358 7076/ 358 5051</b>	Tricity Bendix Service 8 Lammermoor Avenue, Great Barr, Birmingham B43 6ET.
<b>BRIGHTON</b> BN, RH	<b>(0273) 694341</b>	Tricity Bendix Service 31 Bristol Gardens, Kemptown, Brighton BN2 5JR.
<b>BRISTOL</b> BA, BS, SN, TA, EX, PL, TQ, TR	<b>(0272) 211876</b>	Tricity Bendix Service 3 Waring House, Redcliffe Hill, Bristol BS1 6TB.
<b>CANVEY ISLAND</b> RM, CM, SS, CO, IG	<b>(0268) 694144</b>	Tricity Bendix Service 2-4 Sandhurst, Kings Road, Canvey Island SS8 0QY.
<b>CARDIFF</b> CF, HR, LD, NP, SA	<b>(0222) 460131</b>	Tricity Bendix Service Guardian Industrial Estate, Clydesmuir Road, Tremorfa, Cardiff CF2 2QS.
<b>EDINBURGH</b> KY, EH, TD, FK	<b>(031) 557 8383</b>	Tricity Bendix Service 33B Haddington Place, Leith Walk, Edinburgh EH7 4AG.
<b>GATESHEAD</b> CA, DL, DH, NE, SR, TS	<b>(091) 493 2025</b>	Tricity Bendix Service Suite 3, Saltwell House, Lobley Hill Road, Gateshead NE8 4DD.

<b>GLASGOW</b> DG, KA, ML, G, PA,	<b>(041) 647 4381</b>	Tricity Bendix Service 20 Cunningham Road, Clyde Estate, Rutherglen, Glasgow G73 1PP.
<b>LEEDS</b> S, DN, HU, YO, WF, HX, HD, LS, HG, BD	<b>(0532) 608511</b>	Tricity Bendix Service 64-66 Cross Gates Road, Leeds LS15 7NN.
<b>LEICESTER</b> LE, DE, CV, NG, LN, PE IP, NR	<b>(0533) 515131</b>	Tricity Bendix Service 10-12 Buckminster Road, Leicester LE3 9AR.
<b>LIVERPOOL</b> CW, CH, LL, L, WA, WN, PR, FY, LA	<b>(051) 254 1724</b>	Tricity Bendix Service Unit 1, Honey's Green Lane, West Derby, Liverpool L12 9JR.
<b>LONDON (NORTH)</b> E, EC, WC, N, NW, W, EN,	<b>(081) 443 3464</b>	Tricity Bendix Service "Enfield Centre", 2-4 Sandhurst, Kings Road, Canvey Island SS8 0QY.
<b>LONDON (SOUTH)</b> SE, SM, CR, BR, SW1-20	<b>(081) 658 9069</b>	Tricity Bendix Service 127 Croydon Road, Beckenham, Kent BR3 3RA.
<b>LONDON (WEST)</b> AL, CB, LU, MK, SG, WD, HA, UB, TW	<b>(081) 965 9699</b>	Tricity Bendix Service 842 Coronation Road, Park Royal, London NW10 7QA.
<b>OXFORD</b> GL, HP, NN, OX, SL, RG	<b>(0993) 704411</b>	Tricity Bendix Service Suite 3, Windrush Court, 56A High Street, Witney OX8 6BL.
<b>PORTSMOUTH</b> BH, DT, PO, SO, SP, KT, GU	<b>(0705) 667411</b>	Tricity Bendix Service Limberline Road, Hilsea, Portsmouth PO3 5JJ.
<b>TONBRIDGE</b> CT, DA, ME, TN	<b>(0732) 357722</b>	Tricity Bendix Service 61-63 High Street, Tonbridge TN9 1SD.

JUNE 1990









## Rating Plate

The rating plate is situated on the inside of the appliance, along the bottom of the front frame and can be seen by opening the oven door. It gives the MODEL AND SERIAL NUMBER, which should be quoted in any communication or if the service department is contacted.

It is advisable to make a note of these below and keep for reference.

MAKE AND MODEL NO.	SERIAL NO.	DATE OF PURCHASE
BS 620 BS 630 BS 610.		

*This handbook is accurate at the date of printing, but will be superseded and should be disregarded if specifications or appearance are changed in the interests of continued improvement.*

**TRICITY BENDIX**

**we'll do the homework**

55-59 High Road,  
Broxbourne, Herts. EN10 7HJ.

Part No. 3110212-00 00

Tel: 0992 469080.