



MODEL G5347 1/2" EXTREME DUTY IMPACT WRENCH INSTRUCTION SHEET

⚠ WARNING	
	EYE/EAR INJURY HAZARD! Wear safety glasses and hearing protection when using this tool!
	INJURY HAZARD! Always disconnect tool from air to prevent unexpected operation during service!
	DO NOT EXCEED 120 PSI! Exceeding this PSI may result in injury/tool damage.
	SHATTERING HAZARD! Use sockets rated for impact wrench use only.



Figure 1. Model G5347

Specifications

Drive Size	1/2"
Bolt Size Capacity	9/16"
No-Load Speed	7000 RPM
Maximum Torque	400 ft/lb
Air Inlet Size	1/4" NPT
Air Consumption	4.5 CFM
Operating Pressure	90 PSI
Weight	6 lbs.

Operation

Attach any 1/2" drive socket onto your air impact wrench. To change the rotational direction, push the air valve knob. To adjust the torque setting, turn the air valve knob from 0 to 5, 5 being the highest setting (**Figure 1**). Connect the impact wrench to an air line regulated at 90 PSI.

Air Supply

The impact wrench **MUST** be regularly lubricated. Place 3-4 drops of air tool oil directly into the air fitting before each use. For best results, we recommend using an in-line filter, lubricator, and regulator, as shown in **Figure 2**.

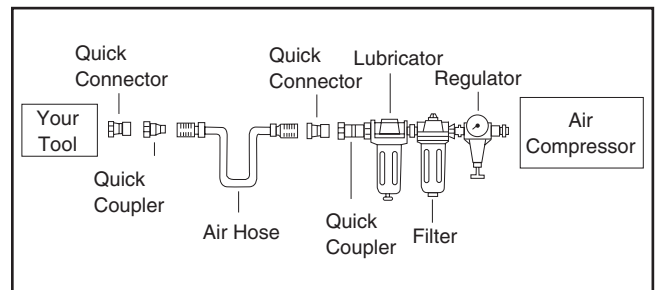

Figure 2. Installing your tool.

If you need help with your new pneumatic tool, call our Tech Support at: (570) 546-9663.

COPYRIGHT © MAY, 2008 BY GRIZZLY INDUSTRIAL, INC.

WARNING: NO PORTION OF THIS MANUAL MAY BE REPRODUCED IN ANY SHAPE OR FORM WITHOUT THE WRITTEN APPROVAL OF GRIZZLY INDUSTRIAL, INC.

#JM10778 PRINTED IN TAIWAN

G5347 Parts Breakdown and List

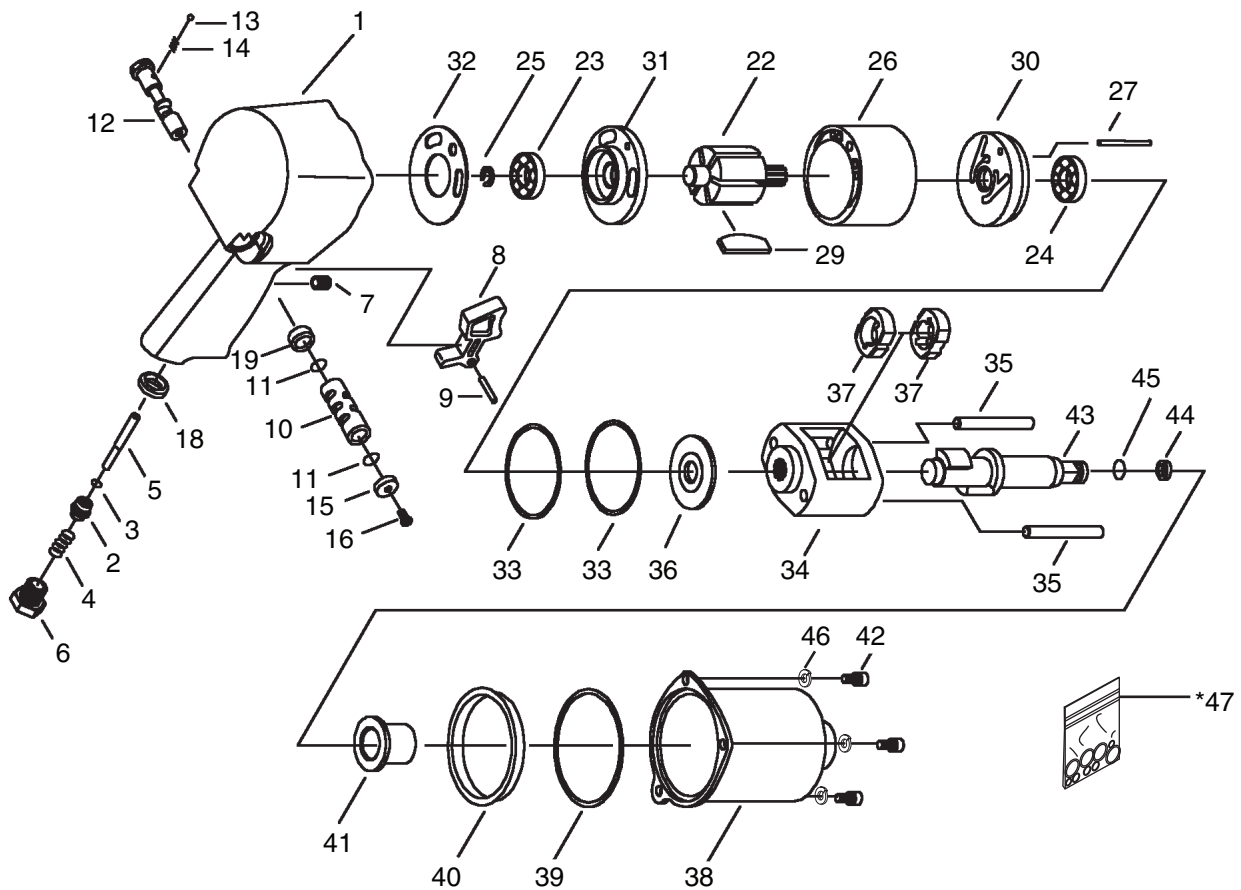

REF	PART #	DESCRIPTION
1	P5347001	GUN BODY
2	P5347002	THROTTLE VALVE
3	P5347003	O-RING
4	P5347004	COMPRESSION SPRING
5	P5347005	VALVE STEM
6	P5347006	AIR INLET VALVE
7	P5347007	SET SCREW
8	P5347008	TRIGGER
9	P5347009	ROLL PIN
10	P5347010	REVERSE VALVE BUSHING
11	P5347011	O-RING
12	P5347012	AIR VALVE KNOB
13	P5347013	STEEL BALL
14	P5347014	COMPRESSION SPRING
15	P5347015	REGULATOR VALVE KNOB
16	P5347016	SPECIAL SCREW
18	P5347018	BUSHING
19	P5347019	REGULATOR BUSHING
22	P5347022	ROTOR
23	P5347023	BALL BEARING
24	P5347024	BALL BEARING
25	P5347025	RETAINING RING

REF	PART #	DESCRIPTION
26	P5347026	CYLINDER
27	P5347027	DOWEL PIN
29	P5347029	ROTOR BLADE
30	P5347030	FRONT END PLATE
31	P5347031	REAR END PLATE
32	P5347032	GASKET
33	P5347033	MOTOR CLAMP WASHER
34	P5347034	HAMMER CAGE
35	P5347035	HAMMER PIN
36	P5347036	SPACER
37	P5347037	HAMMER
38	P5347038	HOUSING COVER
39	P5347039	FRONT GASKET
40	P5347040	HOUSING COVER PILOT
41	P5347041	BUSHING
42	P5347042	CAP SCREW
43	P5347043	ANVIL
44	P5347044	SOCKET SET RING
45	P5347045	O-RING
46	P5347046	LOCK WASHER
*47	P5347047	O-RING KIT

* Not Included; for aftermarket purchase only