

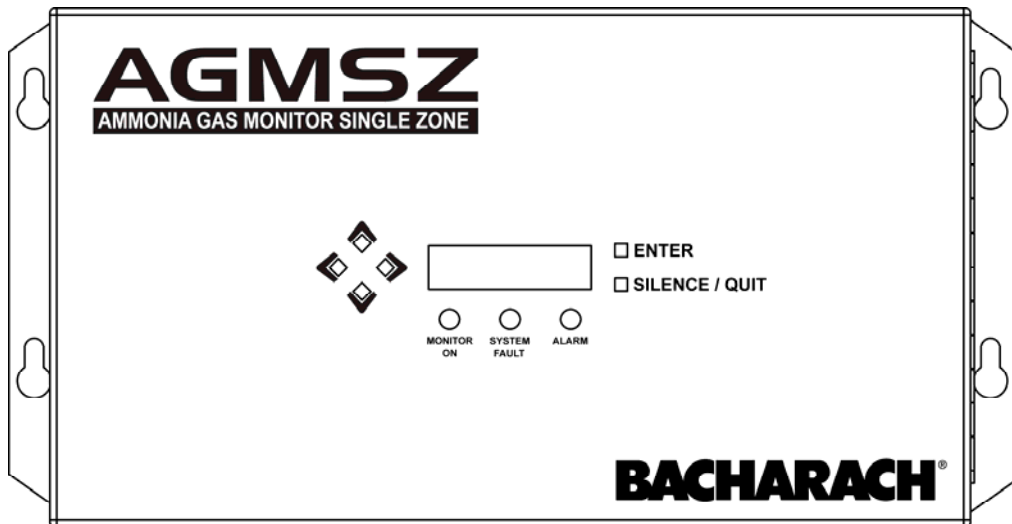

AGMSZ Ammonia Gas Monitor Single Zone

Instruction 3015-4286
Installation / Operation / Maintenance

Rev. 0 – September 2005



WARRANTY

Bacharach, Inc. warrants to Buyer that at the time of delivery this Product will be free from defects in material and manufacture and will conform substantially to Bacharach Inc.'s applicable specifications. Bacharach's liability and Buyer's remedy under this warranty are limited to the repair or replacement, at Bacharach's option, of this Product or parts thereof returned to Seller at the factory of manufacture and shown to Bacharach Inc.'s reasonable satisfaction to have been defective; provided that written notice of the defect shall have been given by Buyer to Bacharach Inc. within two (2) years after the date of delivery of this Product by Bacharach, Inc.

Bacharach, Inc. warrants to Buyer that it will convey good title to this Product. Bacharach's liability and Buyer's remedy under this warranty of title are limited to the removal of any title defects or, at the election of Bacharach, to the replacement of this Product or parts thereof that are defective in title.

The warranty set forth in paragraph 1 does not apply to parts the Operating Instructions designate as having a limited shelf-life or as being expended in normal use (e.g., filters).

THE FOREGOING WARRANTIES ARE EXCLUSIVE AND ARE GIVEN AND ACCEPTED IN LIEU OF (I) ANY AND ALL OTHER WARRANTIES, EXPRESS OR IMPLIED, INCLUDING WITHOUT LIMITATION THE IMPLIED WARRANTIES OF MERCHANTABILITY AND FITNESS FOR A PARTICULAR PURPOSE: AND (II) ANY OBLIGATION, LIABILITY, RIGHT, CLAIM OR REMEDY IN CONTRACT OR TORT, WHETHER OR NOT ARISING FROM BACHARACH'S NEGLIGENCE, ACTUAL OR IMPLIED. The remedies of the Buyer shall be limited to those provided herein to the exclusion of any and all other remedies including, without limitation incidental or consequential damages. No agreement varying or extending the foregoing warranties, remedies or this limitation will be binding upon Bacharach, Inc. unless in writing, signed by a duly authorized officer of Bacharach.

Register Your Warranty by Visiting www.bacharach-inc.com

Declaration of Conformity

Manufacturer's name:	Bacharach, Inc.
Manufacturer's address:	621 Hunt Valley Circle New Kensington, PA 15068
European Operations:	Bacharach Europe Sovereign House, Queensway Leamington Spa Warwickshire CV31 3JR United Kingdom
Product Name:	AGMSZ (Ammonia Gas Monitor Single Zone) conforms to the following harmonized European EMC standards: EN61326-1 EN61000 EN55022

Notice:

Product improvements and enhancements are continuous; therefore the specifications and information contained in this document may change without notice.

Bacharach, Inc. shall not be liable for errors contained herein or for incidental or consequential damages in connection with the furnishing, performance, or use of this material.

No part of this document may be photocopied, reproduced, or translated to another language without the prior written consent of Bacharach, Inc.

Copyright © 2005, Bacharach, Inc., all rights reserved.

BACHARACH® is a registered trademark of Bacharach, Inc. All other trademarks, trade names, service marks and logos referenced herein belong to their respective owners.

Table of Contents

INTRODUCTION	1
How to Use This Manual.....	1
Warning Statements.....	1
Caution Statements.....	1
Hazard Symbols on Monitor.....	1
Safety Precautions.....	2
AC Power Supply.....	2
Protective Grounding.....	2
Explosive Atmosphere.....	2
Proper Exhaust Venting.....	2
Working Inside Monitor.....	2
Misuse and Modifications to Monitor.....	2
In Case of Malfunction.....	2
Fusing.....	2
Installation Category.....	2
Altitude Limit.....	2
Cleaning.....	2
Functional Overview.....	3
General Description.....	3
Understanding Monitoring Levels.....	3
Suggested Location of Sampling Point.....	4
INSTALLATION	5
Installation Considerations.....	5
Warnings and Cautions.....	5
Inspection.....	5
Locating the Monitor.....	5
Mounting Instructions.....	6
Connecting Gas Sample, Purge, and Exhaust Lines.....	6
Overview.....	6
Tubing Considerations.....	7
Connecting the Gas-Sample Line.....	7
Connecting the Purge Line.....	7
Connecting the Exhaust Line.....	7
Interior Schematic.....	8
Electrical Wiring.....	9
Connecting External Alarms.....	10
Overview.....	10
Connection.....	10
4–20 mA Current Loop Interface.....	11
OPERATION	13
Front Panel Display and Controls.....	13
General Operation.....	13
Display Screens.....	14
Initial Power Up.....	14
Data Display Screen.....	14
Function Screens.....	15
Working with Gas Alarms.....	18
Overview.....	18
Clearing / Silencing a Gas Alarm.....	18
Viewing the Gas Alarm Log.....	18

Working with System Faults	18
Overview	18
Clearing / Silencing a Fault Alarm	18
Viewing the Fault Log	19
Fault Codes.....	19
Clearing the Stored PPM Log, Alarm & Fault Data	20
Working with the P-CHK Function	20
Overview	20
Keypad Functions	20
Screen Display.....	20
Working with the DIAGNOS Function	21
Overview	21
Keypad Functions	21
First Diagnostic Screen	21
Second Diagnostic Screen	21
Working with the Calibration Function.....	22
Overview	22
Calibration Procedure.....	22
Adjusting Calibration Factor	22
MAINTENANCE	23
Warnings and Cautions.....	23
Hydrophobic Filters	23
Servicing Air Lines & Termination Filters	23
Clock Battery	23
Sample Pump.....	23
Replacement Parts & Optional Accessories	24
Replacement Parts	24
Optional Accessories	24
Service Centers	25
Specifications	26

Introduction

How to Use This Manual

Thank you for investing in a **BACHARACH** AGMSZ (Ammonia Gas Monitor Single Zone).

This manual provides important information on how to install, operate, and service the AGMSZ monitoring unit.

To assure operator safety and the proper use of the monitor, please read, understand, and follow the contents of this manual.

If you have a working knowledge of gas monitors, you will find this manual useful as a reference tool. If you are new to the use of gas monitors, you can educate yourself about the principles of gas detection and the proper operation of this device by reading this manual thoroughly.

Warning Statements

The use of the word **WARNING** in this manual denotes a potential hazard associated with the use of this equipment. It calls attention to a procedure, practice, or condition, or the like, which if not correctly performed or adhered to, could result in personal injury or death.

Caution Statements

The use of the word **CAUTION** in this manual denotes a potential hazard associated with the use of this equipment. It calls attention to a procedure, practice, condition, or the like, which if not correctly performed or adhered to, could result in damage to the equipment.

Hazard Symbols on Monitor



This symbol indicates the need to consult this operating instruction manual when opening the enclosure.

WARNING: A potential risk exists if the operating instructions are not followed.



This symbol indicates the presence of electric shock hazards when the enclosure is opened.

WARNING: To avoid risk of injury from electric shock, do not open the enclosure without first disconnecting AC power.

Safety Precautions

AC Power Supply

The AGMSZ uses a universal power supply that is capable of accepting inputs of 100 to 240 VAC, 50/60 Hz. The monitor's power consumption is 15 Watts. It is highly suggested that the monitor be connected directly to the AC power source, preferably on its own circuit (with UPS or surge protection).

A switch or circuit breaker rated 1.0 A, 250 VAC, with a minimum terminal spacing of 3.0 mm must be attached to the monitor's AC power leads. This switch must also be located in close proximity to the monitor, and be in easy reach of the operator. This switch should also be clearly marked as the monitor's main AC disconnect device.

Protective Grounding

Under no circumstances should the AGMSZ be operated without connection to a protective ground. Doing so poses a potential shock hazard and is also a violation of electrical safety standards applicable to this type of equipment.

Explosive Atmosphere

Do not operate this equipment in the presence of flammable liquids, vapors or aerosols. Operation of any electrical equipment in such an environment constitutes a safety hazard.

Proper Exhaust Venting

It is imperative that the monitor's exhaust port be vented as described in this manual. Failure to do so may constitute a safety hazard.

Working Inside Monitor

Extreme care should be exercised when accessing the interior of the monitor. Only qualified electrical maintenance personnel should perform connections and adjustments. Always remove AC power before working inside the monitor.

Misuse and Modifications to Monitor

The protection provided by the monitor may be impaired if the monitor is used in a manner not specified by Bacharach, Inc. Changes or modifications to this monitor, not expressly approved, will void the warranty.

In Case of Malfunction

Do not continue to use this equipment if there are any symptoms of malfunction or failure. In the case of such occurrence, de-energize the power supply and contact a qualified repair technician or the nearest Bacharach Service Center. Use **ONLY** the provided knockouts for electrical and communication wiring. Drilling into the box will void the warranty.

Fusing

F1, F2: 1.0 A, 250 V, Type "F"

Installation Category

Installation Category II, Pollution Degree II, as defined by UL.

Altitude Limit

6,562 ft (2,000 m)

Cleaning

To clean the outside of the case, **DO NOT** use soap and water. **USE** a dry cloth.

Functional Overview

General Description

Ammonia monitors are specified to support compliance to federal, state and local safety codes governing gas emissions. Avoiding significant ammonia loss reduces equipment replacement costs, maintains equipment efficiency, promotes safety, and protects the environment.

The Bacharach AGMSZ (Ammonia Gas Monitor Single Zone) is designed to continuously test for the presence of ammonia gas in an area that is located up to 50 ft (15.2 m) away from the monitor. The AGMSZ displays the type of gas being monitored, along with displaying both the current gas level and the peak gas level detected in that area on its front panel LCD. The monitor retains a log of previous readings that can be easily accessed for analysis.

An audible alarm and front panel indicators are provided to signal alarm and fault conditions, and relay contacts are provided that can be used to trigger external alarm devices in the event of a system fault, or if a leak (small), spill (medium), or evacuation (large) level of gas is detected. The system also includes a 4–20 mA current loop interface that can be connected to remote monitoring equipment.

The AGMSZ requires only minor periodic maintenance such as the occasional replacement of filters. The monitor incorporates active diagnostics that continuously check the system for proper operation. A front panel indicator is provided to alert an operator of system malfunctions, and fault codes are generated that enable the operator to identify the cause of the fault.

Understanding Monitoring Levels

Effective use of this monitor requires an understanding of what constitutes reasonable alarm set points for the type of gas being monitored. Most systems leak some gas. In a good “tight” installation these background levels will be acceptably low and often do not require corrective action. You can reduce nuisance alarms and needless service calls if the alarm levels are set at practical limits.

The AGMSZ is shipped with its leak, spill, and evacuate alarm levels set at 100, 300, and 500 ppm, respectively. Setting the monitor at these recommended alarm levels will satisfy the needs of most users. However, the ppm levels generated by system leaks into the environment are greatly influenced by the volume of air in the sampling area, air circulation, size of the leak, distance to the monitoring point, and a host of other variables. In some cases the alarm set points may need to be adjusted either up or down to achieve effective monitoring.

Suggested Location of Sampling Point

At the point of an ammonia gas leak the gas is nearly pure. As ammonia gas is dispersed into the air, the gas molecules diffuse causing a dilution of the original concentration. The AGMSZ measures the gas concentration at the point the sample is collected. Therefore, if the termination of the collection line is not at the exact point of the gas leak, then the monitor will read a diluted mixture of ammonia gas and air.

It should be noted that when ammonia gas is cold it is heavier than air and settles below the leak point, but as the gas warms to room temperature it becomes lighter than air and tends to collect above the leak point. Consequently, the sampling point should ideally be located as close as possible to the source of a potential leak. If this is impractical, then the alarm set points should be adjusted to compensate for the dilution of the ammonia gas.

The AGMSZ should be mounted outside of the mechanical room or at least just inside of a door to the room. This is the “split architecture design” for safety of the operator. The monitor should be readily accessible for easy visual monitoring and servicing. The gas-sample line can be up to 50 ft (15.2 m) in length. If the area around the monitor is not well ventilated, then an optional exhaust line and purge line can be run to an outside location. The length of the exhaust line cannot exceed 50 ft (15.2 m), while the length of the purge line cannot exceed 100 ft (30.4 m).

It may be necessary to perform a “smoke” test of the mechanical room to determine the best monitoring point. The smoke test would provide the pattern of air currents present in the room.

AGMSZ Refrigerant Gas Leak Monitor Mechanical Room Placement

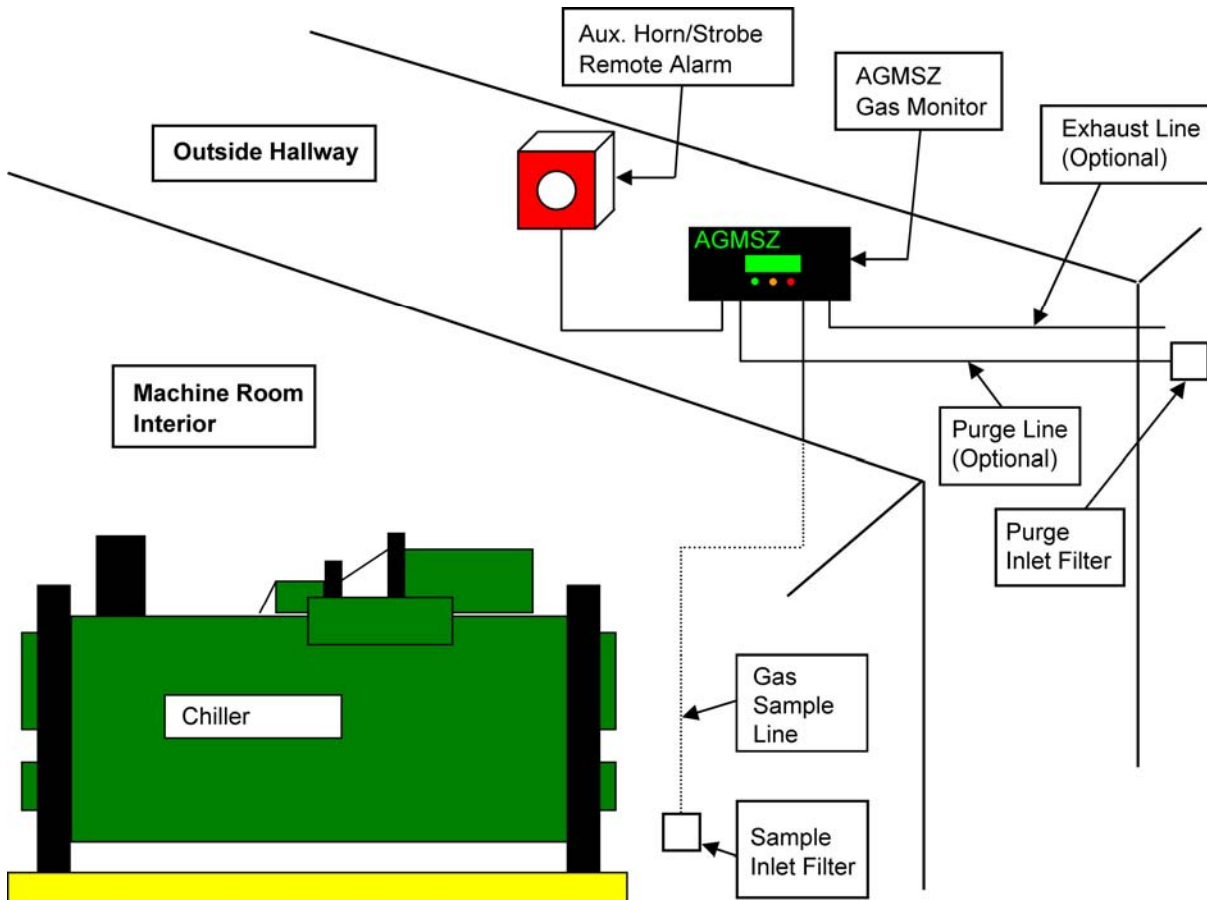

Installation

Installation Considerations

Warnings and Cautions



WARNING: *Explosion hazard! Do not mount the AGMSZ in an area that may contain flammable liquids, vapors or aerosols. Operation of any electrical equipment in such an environment constitutes a safety hazard.*

WARNING: *Shock hazard! Always disconnect AC power before working inside the monitor.*

CAUTION: *Drilling holes in the AGMSZ enclosure may damage the unit and will void the warranty. Please use knockouts provided for electrical connections.*

CAUTION: *The AGMSZ contains sensitive electronic components that can be easily damaged. Be careful not to touch or disturb any of these components.*

Inspection

The AGMSZ has been thoroughly inspected and tested prior to shipment from the factory. Nevertheless, it is recommended that the monitor be re-checked prior to installation. Inspect the outside of the enclosure to make sure there are no obvious signs of shipping damage. Open the enclosure and inspect the interior of the monitor for loose components that may have become dislodged during shipment. If damage is discovered, please contact the nearest Bacharach Service Center for assistance.

Locating the Monitor

Locate the AGMSZ so that no more than 50 ft (15.2 m) of tubing will be needed to reach the sampling area. **Since the monitor uses ambient air to purge its gas sensor, the monitor should be located in a well ventilated area that does not contain refrigerant gas.** If this is not possible, then it is recommended that a separate purge line be run to an area known to contain fresh (zero) air. The length of this purge line should not exceed 100 ft (30.4 m). If the monitor is located in a confined space, then it is also recommended that a separate exhaust line be run to the outside. The length of this exhaust line should not exceed 50 ft (15.2 m).

The AGMSZ should be operated in an environment that is between 32 and 122°F (0 and 50°C); has a relative humidity of between 5 and 90% non-condensing; and is at an altitude of no more than 6,562 ft (2,000 m). The area should also be relatively free of dirt, grease, and oils that could adversely affect the operation of the monitor.

The location should allow the monitor to be easily accessible for visual monitoring and servicing.

Mounting Instructions

The AGMSZ should be installed plumb and level and securely fastened to a rigid mounting surface.

The enclosure utilizes keyhole mounting brackets designed for #12 pan head screws. Locate the four screws as shown in the diagram below and leave the screw heads protruding approximately 3/16".

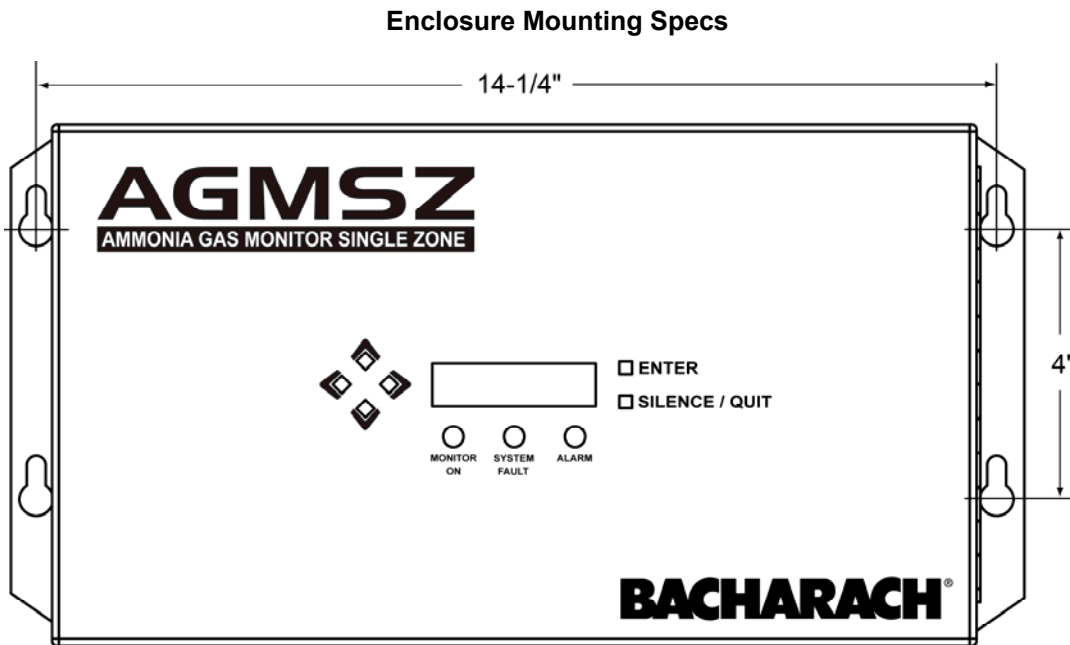

Hold the monitor flat against the mounting surface and allow it to slide down engaging the screw heads in the keyhole slots of the mounting brackets. Adjust the screws as necessary to hold the monitor securely against the mounting surface.

Connecting Gas Sample, Purge, and Exhaust Lines

Overview

A single gas-sample line needs to be run from the AGMSZ to the area of the facility to be monitored. An optional purge line can be run to bring fresh (zero) air into the monitor for detector zeroing purposes. And an optional exhaust line can be installed to vent the sample gas away from the monitor. All tubing connections are made on the bottom of the enclosure as shown in the illustration below.

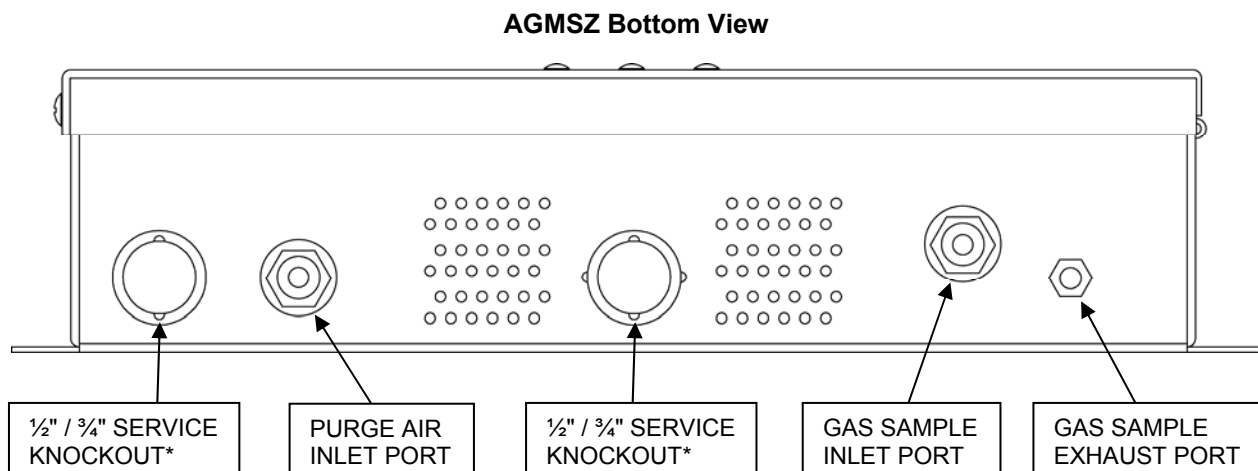

* There is an additional Service Knockout on top of the case

Tubing Considerations

Use ¼" outside diameter (0.040" wall) flex tubing for all air lines (P/N 304-2742 or equivalent). The tubing should be clean and free of moisture or other contaminants. The tubing should be cut cleanly with a sharp knife and care should be taken not to distort the tubing end.

IMPORTANT! *Due to the reactive nature of ammonia gas, it is important to use materials that will not absorb the gas as it passes through the sampling system. The use of unauthorized tubing or any other materials in the gas-sampling stream may lead to erroneously low readings.*

All tubing bends should have a radius of no less than 5" to insure proper airflow. If kinks or obstructions occur in the line the monitor may not function properly.

Connecting the Gas-Sample Line

Please refer to Section *Suggested Location of Sampling Point* (Page 4) to learn more about where to take a gas sample.

The gas-sample line can be up to **50 ft (15.2 m)** in length. The end of this line should be placed near the potential leak source and positioned to reduce the possibility of mists, aerosols, oil, water, dust, or other contaminants from being drawn into the monitor. For added protection, a termination filter (P/N 3015-3420) supplied with the monitor must be attached to the end of this line.



CAUTION: *The introduction of contaminants through the gas-sample line can result in serious and permanent damage to the monitor.*

Connecting the Purge Line

The purge line functions to bring fresh (zero) air into the monitor for the purpose of purging the detector and setting its baseline zero reading. This purge line is required if the monitor is located in an area that contains ammonia gas or other types of refrigerant.

The purge line can be up to **100 ft (30.4 m)** in length. This line should terminate in an area known to contain fresh air. To connect the purge line to the monitor, simply push the tubing into the Purge Air Inlet Port. If the purge line terminates outside the building, position the tubing so that no water or moisture can enter the line. For added protection from contaminants entering the monitor, a termination filter (P/N 3015-3420) must be attached to the end of this line.

Connecting the Exhaust Line

The exhaust line functions to carry the exhausted gas sample away from the monitor, and is required if the monitor is located in a confined, poorly ventilated area. If no purge line is used, it is a good idea to vent the exhausted gas sample away from the monitor to prevent erroneous readings due to improper zeroing of the detector.

The exhaust line can be up to **50 ft (15.2 m)** in length. Ideally this line should terminate outdoors in a location that is not exposed to the elements. Connect the exhaust line to the monitor by firmly pushing the tubing onto the Gas Sample Exhaust Port's barbed fitting. Ensure that no loops or dips are present that could trap condensate. This is likely as outside air can be cooler than instrument. Note that the exhaust line does not require a termination filter.

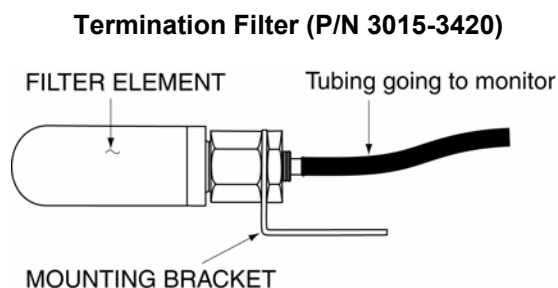

Interior Schematic

Interior Schematic

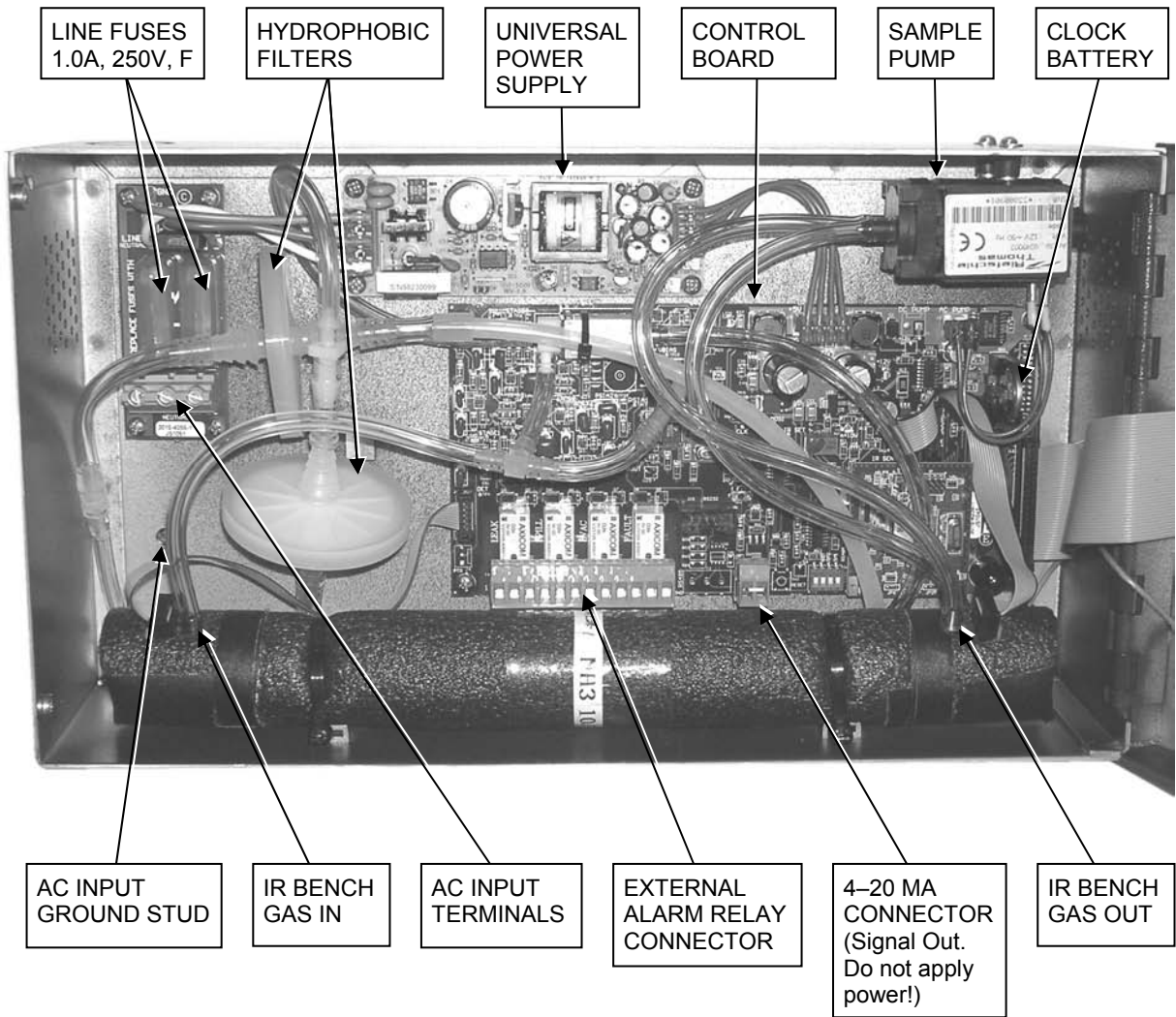

Electrical Wiring

The AGMSZ uses a universal power supply that is capable of accepting inputs of 100 to 240 VAC, 50/60 Hz. The monitor's power consumption is 15 Watts. It is highly recommended that the monitor be connected directly to the AC power source, preferably on its own circuit. The connection should be completed with UL approved multi-conductor wire (14–18 AWG), rated 300 VAC at 105°C.

Locate a convenient service knockout and install electrical conduit in the typical manner.

Locate the AC Input Terminals and Ground Stud on the inside of the monitor (Page 8).

Secure the incoming AC power live (black) and neutral (white) wires to the LINE 1 and LINE 2 terminals.

Using the supplied crimp-on ring terminals, washers, and nuts, connect the incoming AC power ground wire (green) to the monitor's AC Input Ground Stud, and then install a separate wire between the ground stud and the GND terminal.

A switch or circuit breaker rated 1.0 A, 250 VAC, with a minimum terminal spacing of 3.0 mm must be attached to the monitor's AC power leads. This switch must also be located in close proximity to the monitor, and be in easy reach of the operator. This switch should also be clearly marked as the monitor's main AC disconnect device.

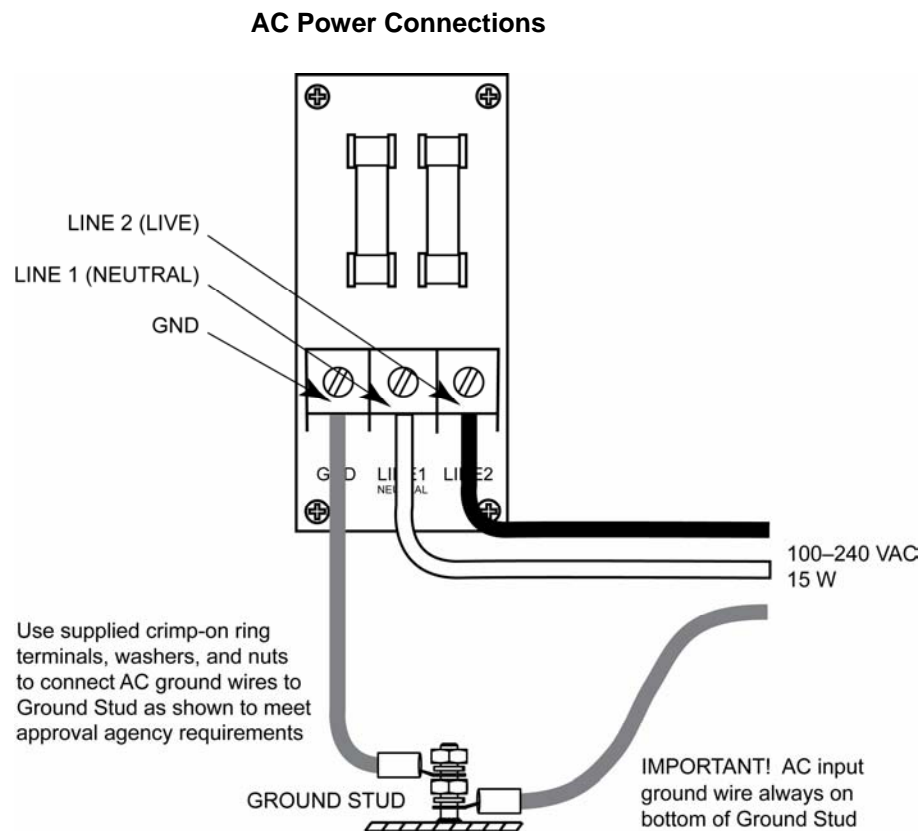

WARNING: *Electrical installation should be performed by a certified electrician, and should comply with all applicable NEC/CEC and local electrical safety codes.*

WARNING: *The AC power ground wire must first be connected to the monitor's ground stud. Under no circumstances should this monitor be operated without a protective ground. Doing so poses a potential shock hazard, and is also a violation of electrical safety standards applicable to this type of equipment.*

CAUTION: *Drilling holes in the AGMSZ enclosure may damage the unit and will void the warranty. Please use knockouts provided for electrical connections.*

Connecting External Alarms

Overview

The AGMSZ includes four SPDT relays whose contacts are rated 3 A at 240 VAC. These relays are used for the connection of external alarm devices that are activated when the relay is energized. The relays are factory assigned to energize under the following conditions:

Relay #1	Leak	Alarm Point 100 ppm
Relay #2	Spill	Alarm Point 300 ppm
Relay #3	Evacuate	Alarm Point 500 ppm
Relay #4	Fault	System Fault Event

Note that the alarm points of relays #1, #2, and #3 are set using the monitor's **LEAKLVL**, **SPILLLVL**, and **EVACLVL** function screens (Page 16).

Connection

Use any of the service knockouts to gain cable access to the interior of the monitor. Locate the External Alarm Relay Connector (Page 8). Secure the leads from the external alarm device and its power source to the connector as shown in the diagram below.

The diagram on Page 11 shows a typical alarm device being connected to Relay 1. Note how power to this device is being tapped off the monitor's AC input.

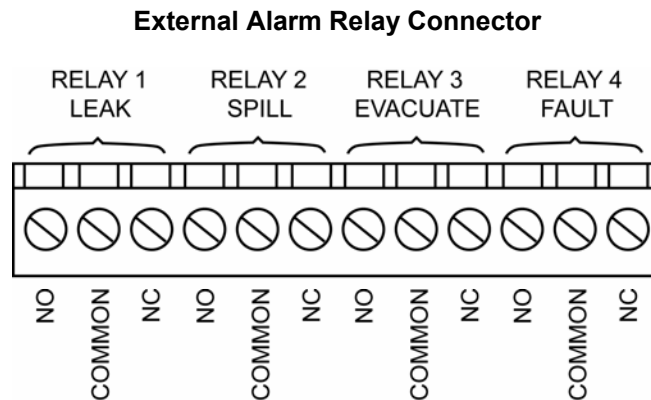

Each relay may be connected as normally open (NO), or normally closed (NC).

The relay contacts are rated 3 A at 250 VAC.

Power for the external alarm devices may be supplied from an external power source, or from the monitor's AC input terminals.

Typical External Alarm Relay 1 Wiring

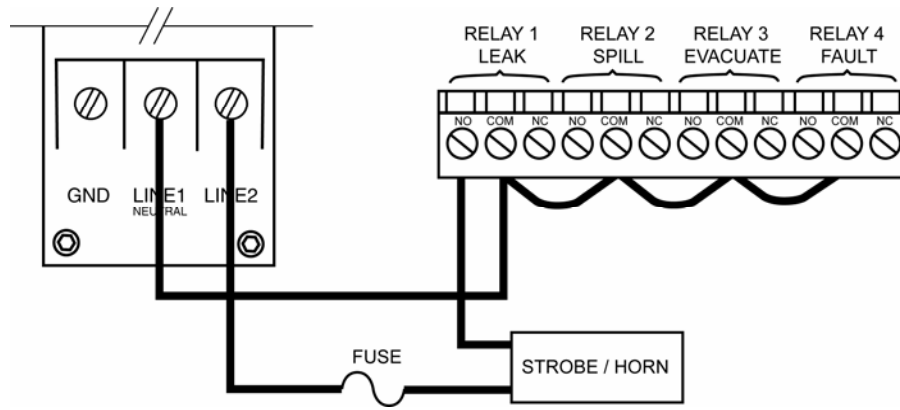

Jumper the 'Neutral' line of an external power source or the monitor's AC input to the 'Common' terminals on the relay connector.

Connect one end of the strobe or horn to the 'NO' terminal of whichever level of alarm is appropriate for the application.

The other end of the strobe or horn is connected to the other leg of the external power source. For protection, install an in-line fuse of the appropriate size and design for the external alarm device being used.

4–20 mA Current Loop Interface

An external 4–20 mA monitoring device (e.g., chart recorder) can be connected to the AGMSZ using a shielded-twisted-pair cable. Use any of the service knockouts to gain access to the interior of the monitor. Locate the 4–20 mA Connector (Page 8), remove it from the circuit board, and then remove the resistor or shorting wire from its terminals.

IMPORTANT! *The monitoring device must be isolated from ground (floating).*

NOTE: *A 100 ohm, ¼ W resistor must be connected to the 4–20 mA connector if no external monitoring device is used. Failure to install this resistor may cause a loop fault code <0010> to occur (Page 19).*

Secure the wire leads from the external monitoring device to the 4–20 mA connector as shown in the diagram below, making sure that the polarity at this connector matches the wiring at the monitoring device.

The default current-to-ppm factor is set to 0.016 mA = 1 ppm, providing a measurement range 0 ppm (4 mA) to 1,000 ppm (20 mA). Note that the current-to-ppm factor can be changed using the monitor's **LOOP** function (Page 16).

To facilitate loop zero and span checking, note that when the **LOOP** function is selected the loop output is set to 20 mA, and upon exiting this function the loop output is set to 4 mA.

4–20 mA Current Loop Connector

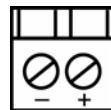

CAUTION: *Never apply power to the 4–20 mA Current Loop Connector from an external power supply. Connect only a load resistor and/or a floating measurement device.*

Notes:

Operation

Front Panel Display and Controls

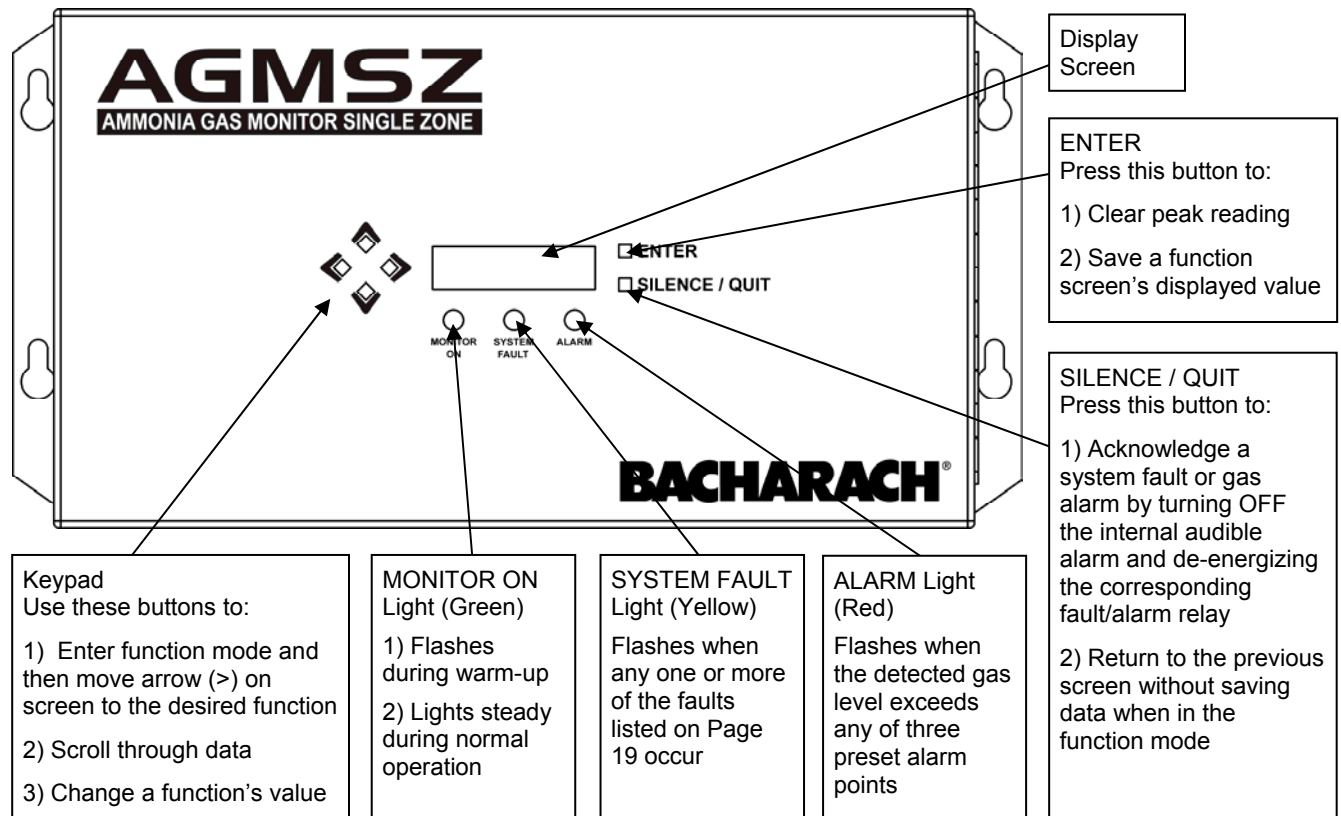

General Operation

Once the AGMSZ has been installed, set up, and powered ON, the monitor will make measurements in the area being sampled for ammonia gas without further operator intervention. The results of those measurements are shown on the front panel display.

```
MEASURE  00485pk
         45ppm R717
```

In the example shown above, **MEASURE** indicates that the AGMSZ is actively monitoring for refrigerant gas, and that currently 45 ppm of R-717 (ammonia gas) is being detected. This display also indicates that a peak measurement of 485 ppm has been made.

An operator can reset the peak value to zero by pressing the **ENTER** button.

A log of up to 200 previous measurements can be viewed using the **PPM LOG** function (Page 15).

If the detected gas level exceeds the preset Leak, Spill, or Evacuate alarm point, then the monitor responds by turning ON the front panel **ALARM** (red) light and energizing the corresponding alarm relay. If the internal audible alarm is turned ON, it too will activate (**AUDALRM** page 16). Optional external alarm devices can be connected to the alarm relays to alert personnel that a Leak, Spill, or Evacuate alarm condition has occurred (Page 10). Pressing the front panel **SILENCE** button will acknowledge an alarm and turn OFF all alarm indicators with the exception of the front panel **ALARM** light. The alarm circuit will reactivate, however, if the alarm condition is not cleared within the time period set by the **SILENCE** function (Page 17). The **ALARM** light will turn OFF after the detected gas level goes below the lowest alarm point and after the **SILENCE** button is pressed.

If a system fault occurs (see Fault Code list on Page 19), the monitor responds by turning ON the front panel **SYSTEM FAULT** (yellow) light and energizing the fault relay. If the internal audible alarm is turned ON, it too will activate (**AUDALRM** page 16). An optional external alarm device can be connected to the fault relay to alert personnel that a system fault has occurred (Page 10). Pressing the front panel **SILENCE** button will acknowledge the fault and turn OFF all alarm indicators with the exception of the front panel **SYSTEM FAULT** light. The alarm circuit will reactivate, however, if the fault condition is not cleared within the time period set by the **SILENCE** function (Page 17). The **SYSTEM FAULT** light will turn OFF only after the cause of the fault has been eliminated.

A log of the alarm and fault events can be viewed using the monitor's **ALARMS** and **FAULTS** function (Page 15).

Display Screens

Initial Power Up

When the AGMSZ is first powered up all front panel lights are turned ON, and a splash screen appears showing the monitor's firmware revision level. After a brief moment the **Warm Up** screen is display along with the front panel **MONITOR ON** light (green) blinking.

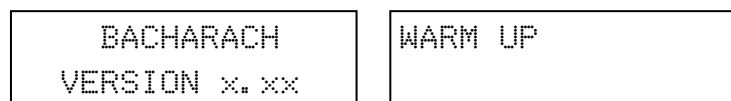

The monitor takes 15 minutes to warm up; after which, the **MONITOR ON** light glows steady and the **Data Display** screen is displayed.

Data Display Screen

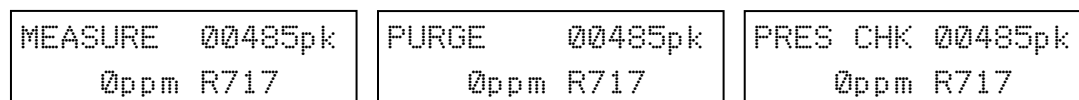

During normal operation, the **Data Display** screen shows when the monitor is performing the following three functions:

MEASURE indicates that the monitor is actively measuring for refrigerant gas. In the example screens shown above, the monitor is currently detecting 0 ppm of R-717 (ammonia gas), and that a peak measurement of 485 ppm has occurred.

To reset the peak value to zero, press the **ENTER** button.

PURGE is displayed when the monitor is resetting its infrared detector to a baseline of 0 ppm using fresh (zero) air that is being drawn in through the Purge Air Inlet Port. This purging process is performed on an "as needed" basis, which is normally once every 6 to 8 minutes.

PRES CHK is displayed when the monitor is performing an atmospheric pressure check, which is done to ensure the accuracy of the gas measurement under varying atmospheric conditions. This pressure check is performed every 30 minutes.

Function Screens

The Function screens are used to display stored data and to set up the monitor.

From the **Data Display** screen, press any **Keypad** button to display the first **Function Menu** screen. Next, use the **Keypad** buttons to move the arrow (>) on the display until it is next to the desired function, and then press the **ENTER** button to select that function.

>PPM LOG FAULTS ALARMS DIAGNOS	>LOG INT AUDALRM LOOP CLOCK	>P-CHK
>GASTYPE SPILLVL LEAKLVL EVACLVL	>SILENCE ZONETMP SQUELCH CAL	

Once a function has been selected, use the **Keypad** to scroll through the displayed data or to change a parameter associated with that function. Press **ENTER** to save newly entered parameters. Press the **QUIT** button to return to the previous screen without saving.

Note that if no buttons are pressed within 90 seconds after selecting a function, the monitor returns to the **Data Display** screen.

PPM LOG – Contains records of the last 200 measurements. Each record shows the measurement's date, time, and ppm level. Note that the interval at which the measurements are logged is determined by the **LOG INT** function.

```
#025      425PPM @  
11/07/03  15:35
```

Use the **Keypad Up** and **Down** buttons to change the record number by a factor of 1. Use the **Right** and **Left** buttons to change the record number by a factor of 10. Press **QUIT** to return to the previous screen.

In the example on the right, record #025 shows that a level of 425 ppm was measured on 11/07/03 at 15:35.

Note that the PPM Log can be cleared as described in Section *Clearing the Stored PPM Log, Alarm & Fault Data* (Page 20).

ALARMS – Contains records of the last 30 alarm events, with the monitor's most recent alarm being shown when the **Alarm** screen is first displayed. After 30 events have been recorded, the newest record overwrites the oldest. Each record displays either LEAK, SPILL, or EVAC including the date and time the alarm occurred. Use any of the **Keypad** buttons to scroll through the other alarm records. Press **QUIT** to return to the previous screen. Refer to *Working with Gas Alarms* (Page 18).

```
#03      SPILL @  
11/10/03  15:06
```

Note that the ppm levels at which alarms occur are set using the **LEAKLVL**, **SPILLVL**, and **EVACLVL** functions.

In the example on the right, record #03 shows that a spill event occurred on 11/10/03 at 15:06.

FAULTS – Contains records of the last 30 fault events, with the monitor's current fault status being shown when the **Fault** screen is first displayed. After 30 events have been recorded, the newest record overwrites the oldest. Each record lists an event's numeric fault code plus the date and time the fault occurred. Use any of the **Keypad** buttons to scroll through the other fault records. Press **QUIT** to return to the previous screen. Refer to *Working with System Faults* (Page 18).

```
#15 <1000> @  
11/10/03  12:37
```

In the example on the right, record #15 shows that a Purge Flow Fault <1000> occurred on 11/10/03 at 12:37.

DIAGNOS – Enters the diagnostic function. Press the **Up Arrow Keypad** button to toggle between the monitor’s two diagnostic screens. Refer to *Working with the DIAGNOS Function* (Page 21).

```
4.26500v <0000>  
24.5cD 14.00psi
```

```
0.4ppm 0.00  
0.00002au 4.260v
```

GASTYPE – Ammonia monitors do not have a library of other gases to choose from, therefore R717 is the only gas type listed. Press **QUIT** to return to the previous screen.

```
SELECT GAS TYPE  
R717
```

LEAKLVL – Sets the Leak Alarm level, adjustable from 1 to 300 ppm. Factory default is 100 ppm. Note that the Leak Alarm level cannot be set higher than either the Spill or Evacuate Alarm levels. Use the **Keypad** to set the desired Leak Alarm level, and then press **ENTER** to save that level and return to the previous screen.

```
EDIT LEAK LEVEL  
0100 PPM
```

SPILLVL – Sets the Spill Alarm level, adjustable from no lower than the Leak Alarm level to a maximum value of 500 ppm, but not higher than the Evacuate Alarm level. Factory default is 300 ppm. Use the **Keypad** to set the desired Spill Alarm level, and then press **ENTER** to save that level and return to the previous screen.

```
EDIT SPILL LEVEL  
0300 PPM
```

EVACLVL – Sets the Evacuate Alarm level, adjustable from no lower than the Spill Alarm level to 9999 ppm. Factory default is 500 ppm. Use the **Keypad** to set the desired spill level alarm level, and then press **ENTER** to save that level and return to the previous screen.

```
EDIT EVAC LEVEL  
0500 PPM
```

LOG INT – Sets the interval at which measurements are logged to memory from 1 to 9999 minutes. Factory default is 10 minutes. Note that the logged measurements can be viewed using the **PPM LOG** function. Use the **Keypad** to enter the desired value, and then press **ENTER** to save that value and return to the previous screen.

```
LOG INTERVAL IS  
0010 min
```

LOOP – Adjusts the loop factor of the 4–20 mA current loop. Factory default is 0.016 mA per ppm, which provides an output range of 0 ppm (4 mA) to 1,000 ppm (20 mA). Use the **Keypad** to set the desired loop factor, and then press **ENTER** to save that value and return to the previous screen.

```
EDIT LOOP FACTOR  
0.016 mA/PPM
```

To facilitate loop zero and span checking, note that when the **LOOP** function is selected the loop output is set to 20 mA, and upon exiting this function the loop output is set to 4 mA.

AUDALRM – Allows the monitor’s internal audible alarm to be associated with any function of the monitoring system. Factory default is OFF. Use the **Keypad** to select the desired audible alarm function, and then press **ENTER** to save that value and return to the previous screen.

```
AUDIBLE ALARM IS  
OFF
```

Audible Alarm Settings: OFF, ANY ALARM, SYSTEM FAULT, LEAK ALARM, SPILL ALARM, EVAC ALARM, MONITOR STOPPED

NOTE: *MONITOR STOPPED* indicates there is a critical system fault, and the monitor is no longer functioning correctly.

CLOCK – Sets the monitor’s date and time. Use the **Keypad** to enter the correct date and time, and then press **ENTER** to save those values and return to the previous screen. Note that time is displayed in a 24 hour format, while the date is displayed as mm/dd/yy.

```
SET DATE & TIME
11/10/03  15:30
```

SILENCE – Used to enter a length of time for which the internal audible alarm and the external alarm are turned OFF when the front panel **SILENCE** button is pressed. The factory default is 300 seconds (5 minutes). If the cause of the alarm/fault has not been cleared at the end of this time period, the internal audible alarm and the external alarm device are reactivated. Use the **Keypad** to enter the desired time period, and then press **ENTER** to save that value and return to the previous screen.

```
SILENCE TIMEOUT
0300 sec
```

SQUELCH – Sets a value of between 0.0 and 99.9 ppm that prevents the display of measurements below that value. Factory default is 0 ppm. For example, if the squelch setting is set to 50 ppm, then the monitor will not display measurements that are below that value. Use the **Keypad** to enter the desired value, and then press **ENTER** to save that value and return to the previous screen.

```
SQUELCH BELOW
50.0ppm
```

ZONETEMP – Used to enter the temperature of the area being monitored in °C, thus giving a more accurate ppm reading. The factory default is 25°C. Use the **Keypad** to enter the desired temperature, and then press **ENTER** to save that value and return to the previous screen.

```
TEMP AT ZONE =
25 degC
```

CAL – Used to change the monitor’s calibration factor. This function is to be used **ONLY** with instructions from a Bacharach Service Center. Factory default is 1.000.

```
R717 CALFACTOR
1.000
```

P-CHK – This **Pressure Check** function displays the current manifold pressure and the stored ambient pressure in psia, along with the difference between these two pressures and the current fault code. Refer to *Working with the P-CHK Function* (Page 20).

```
14.72 * AMB14.81
0.09dif <0000>
```

Working with Gas Alarms

Overview

If the ammonia gas ppm level in the area being monitored exceeds its preset Leak, Spill, or Evacuate Alarm level (Page 16), the AGMSZ will detect this alarm condition and turn ON the front panel **ALARM** light. Additionally, an external alarm device may activate and the monitor's internal audible alarm may sound if those features have been enabled (Pages 10 & 16).

Clearing / Silencing a Gas Alarm

Once the gas-alarm circuit has been triggered all alarm indicators remain turned ON, even after the detected gas level returns to normal. Press the **SILENCE** button to clear all gas-alarm indicators after the cause of the alarm has been cleared and the detected gas level has dropped below all alarm levels.

Pressing the **SILENCE** button while a gas-alarm condition still exists causes the internal audible alarm and all external alarm devices that are connected to the alarm relays to turn OFF for a period of time as set by the **SILENCE** function (Page 17). The front panel **ALARM** light remains ON, however, as an indication that an alarm condition still exists, but will automatically turn OFF once the gas level returns to normal. The alarm circuit will reactivate at the end of the silence period if the detected gas level is still above an alarm level.

Viewing the Gas Alarm Log

From the **Data Display** screen, use the **Keypad** buttons to place the arrow (>) on the display next to the **ALARMS** function. Then press **ENTER** to display the alarm log.

The alarm log shows the type of alarm (**LEAK**, **SPILL**, or **EVAC**), plus the date and time it occurred. If **CLEAR** is displayed, this indicates that an alarm was acknowledged at the date and time shown.

Immediately after selecting the **ALARM** function, the most recent alarm event is displayed. In the example below, record #03 shows that a Spill Alarm occurred on 11/10/03 at 15:06. Note that if more than 30 alarm events have occurred, then the newest event overwrites the oldest.

#03	SPILL @
11/10/03	15:06

Note that the Alarm Log can be cleared as described in Section *Clearing the Stored PPM Log, Alarm & Fault Data* (Page 20).

Working with System Faults

Overview

If a system malfunction occurs, the AGMSZ will detect the problem and turn ON the front panel **SYSTEM FAULT** light. Additionally, an external alarm device may activate and the monitor's internal audible alarm may sound if those features have been enabled (Pages 10 & 16).

Clearing / Silencing a Fault Alarm

The **SYSTEM FAULT** light and all other fault indicators will automatically turn OFF after the cause of the fault has been eliminated.

Pressing the **SILENCE** button while a fault condition still exists causes the internal audible alarm and the external alarm device that is connected to the fault relay to turn OFF for a period of time as set by the **SILENCE** function (Page 17). The front panel **SYSTEM FAULT** light remains ON, however, as a reminder that a fault condition still exists. The alarm circuit will reactivate at the end of the silence period if the cause of the fault has not been corrected. The **SYSTEM FAULT** light will automatically turn OFF once the fault has been cleared.

Viewing the Fault Log

From the **Data Display** screen, use the **Keypad** buttons to place the arrow (>) on the display next to the **FAULTS** function. Then press **ENTER** to display the fault log.

```
#03 <0800> @
11/12/03 08:17
```

```
#04 <0000> @
11/12/03 08:30
```

```
FAULT CODE<1800>
12 ZONE FLOW
```

```
FAULT CODE<1800>
13 PURGE FLOW
```

The fault log shows the monitor's current fault status. If the fault is still present when the **FAULTS** function is selected, then the current cause of the fault is displayed along with the date and time it occurred. If the cause of the fault has been cleared, then the fault log will show <0000> along with the date and time the fault was cleared. Use the **keypad** buttons to scroll through the fault log. In the examples shown to the left, record #03 shows that a Zone Flow Fault (fault code <0800>) occurred on 11/12/03 at 08:17, while record #04 shows that the fault was cleared on 11/12/03 at 8:30.

The cause of the fault is identified by a numeric fault code. To convert the fault code into a text description of the fault, first press the **ENTER** button and then use the **Keypad** buttons to scroll through the display until the text description of the fault appears. If the fault code is a combination of two or more faults, then continue to use the **Keypad** buttons until all fault text descriptions have been displayed. For example, the fault code <1800> represents the combination of both a Zone Flow <0800> and a Purge Flow <1000> fault as shown to the left.

Note that the Fault Log can be cleared as described in Section *Clearing the Stored PPM Log, Alarm & Fault Data* (Page 20).

Fault Codes

FAULT CODES ARE ADDITIVE. For example: A fault code of <1800> indicates that both a Purge Flow Fault <1000> and a Zone Flow Fault <0800> have occurred.

<0001> Box Temperature Fault: Enclosure temperature is outside normal range (or IR detector has failed). Check that the monitor is not being subjected to extreme temperatures. Verify that the ventilation holes are not obstructed. Use the **DIAGNOS** function (Page 21) to check the Box Temperature.

<0002> Bench Temperature Fault: Optical bench is outside normal operating range (or IR detector has failed). Check that the monitor is not being subjected to extreme temperatures.

<0004> - Manifold Pressure Fault: The manifold pressure is outside normal operating range (or IR detector has failed). Enter the **DIAGNOS** function (Page 21) and record ALL data. Call the factory with this information for further instructions.

<0010> Loop Fault: The 4–20 mA current loop is open, or there is a high resistance in the circuit. Check the wiring to the load/monitoring circuit. If this feature is not being used, a 100 ohm resistor must be connected to the 4–20 mA connector (Page 11).

<0100> Zero Filter Fault: There is refrigerant gas present in the purge air. Locate the monitor in an area containing fresh air, or install a purge air line. Refer to *Locating the Monitor* (Page 5).

<0200> Gain Set Fault: The digipot autotune sequence has failed. This fault will only occur on first boot up or after a firmware upgrade. Call the factory for further instructions.

<0400> A/D Fault: A fault has occurred in the analog-to-digital circuitry. Contact the factory with this information for further instructions.

<0800> Zone Flow Fault: Check for: A kink in the gas-sample line or exhaust line; a blocked external termination filter; a blocked internal hydrophobic filter (Page 8); a failed pump.

<1000> Purge Flow Fault: Check for: A kink in the purge line; a blocked external termination filter; a blocked internal hydrophobic filter (Page 8); a failed pump. Once the blockage has been cleared, the monitor will return to normal operation after the monitor completes a purge cycle.

<4000> Zero Fault: The IR detector's output voltage is out of tolerance. Enter the **DIAGNOS** function (Page 21) and record ALL data. Call the factory with this information for further instructions.

<8000> Clipping Fault: The detector voltage may be out of tolerance. Use the **DIAGNOS** function (Page 21) to check the IR detector voltage. Call the factory with this information for further instructions.

Clearing the Stored PPM Log, Alarm & Fault Data

Up to 200 gas measurements, and 30 alarm and fault events are stored by the monitor.

To clear stored data, first display the data to be cleared by using the **PPM LOG**, **ALARMS** or **FAULTS** function (Page 15). Next, press the **Right Arrow Keypad** and **ENTER** buttons at the same time. A single, long tone should be heard when the data has been successfully cleared.

Working with the P-CHK Function

Overview

The **P-CHK** function (Pressure Check Function) (Page 17) is useful to a service technician for troubleshooting a flow fault problem. The monitor will trigger a flow fault if the pressure drop from ambient is less than 0.2 psi during a purge cycle, and 0.5 psi during a measurement cycle.

Keypad Functions

From the **Data Display** screen, use the **Keypad** buttons to place the arrow (>) on the display next to the **P-CHK** function. Then press **ENTER** to display the **Pressure** screen.

The **Left Arrow Keypad** button toggles the purge valve open and closed. Note that an asterisk (*) appears when the purge valve is open (purging).

The **Down Arrow Keypad** button toggles the pump ON and OFF.

Pressing the **ENTER** button stores the current manifold pressure shown on the left to the ambient pressure shown on the right (must be done with the pump OFF).

Screen Display

14.72 * AMB14.81	Manifold Pressure * Stored Ambient Pressure
0.09dif <0000>	Pressure Difference Fault Code

Manifold Pressure – Current manifold pressure in psia.

Stored Ambient Pressure – Stored ambient pressure in psia.

Pressure Difference – The difference between the current manifold pressure and the stored ambient pressure.

Fault Code – Current fault code (Page 19).

Purge Valve Asterisk (*) – When viewing the **Pressure** screen, the purge valve can be opened and closed by pressing the **Left Arrow Keypad** button. An asterisk appears on the display when the purge valve is *open*.

Working with the DIAGNOS Function

Overview

The **DIAGNOS** function displays sensor data and status information useful to a service technician for troubleshooting various fault conditions. Explanations of the data shown in these screens are given below.

Keypad Functions

From the **Data Display** screen, use the **Keypad** buttons to place the arrow (>) on the display next to the **DIAGNOS** function. Then press **ENTER** to display the first of two **Diagnostic** screens.

Press the **Up Arrow Keypad** button to toggle between the **First** and **Second Diagnostic** screen.

First Diagnostic Screen

4.26500v <0000> 24.5cD* 14.72psi	Bench Voltage Fault Code Detector Temperature °C * Manifold Pressure
0.00250n <0000> 29.5cB* 14.72psi	Noise Fault Code Box Temperature °C * Manifold Pressure

In the first diagnostic screen, the user can toggle between displaying the Bench Voltage / Noise and Detector Temperature / Box Temperature by pressing the **Right Arrow Keypad** button.

Bench Voltage – This is the current peak-to-peak output of the IR detector. In the absence of refrigerant this value can range from 3.90000V to 4.50000V.

Noise – The Noise value is a 16 point running average of the noise portion of the IR detector's output. This reading is valuable mainly when refrigerant is NOT present.

Detector Temperature – This is the current detector temperature in °C.

Box Temperature – This is the current internal enclosure temperature in °C.

Fault Code – Current fault code. A value of <0000> indicates that no faults are being detected.

Manifold Pressure – Current manifold pressure in psia.

Purge Valve Asterisk (*) – The purge valve can be opened and closed by pressing the **Left Arrow Keypad** button. An asterisk appears on the display when the purge valve is *open*.

Second Diagnostic Screen

0.4ppm 0.00 0.00002au*4.260v	PPM Level µMole/Liter Avg. Absorption Unit * Detector Voltage
---------------------------------	---

PPM Level – Parts Per Million Level is the current detected gas level, and is the volume concentration referenced to standard temperature and pressure.

Average Absorption Unit – This is the optical absorbency. In the absence of refrigerant the absorbency is 0.00000 au. When sampling refrigerants, its value varies proportionally with the refrigerant concentration.

µMoles/Liter – This is the absolute concentration in micro-moles per liter of refrigerant.

Detector Voltage – This is a running average of the IR detector's bench voltage as displayed in the **First Diagnostic** screen.

Purge Valve Asterisk (*) – When viewing the diagnostic screen, the purge valve can be opened and closed by pressing the **Left Arrow Keypad** button. An asterisk appears on the display when the purge valve is *open*.

Working with the Calibration Function

Overview

If greater than standard accuracy is desired, the factory's default calibration factor of 1.000 may be adjusted by performing the calibration procedure as described below, and then selecting the monitor's **CAL** function to enter the new calibration factor.

IMPORTANT! *Changing the calibration factor will VOID the factory calibration. Typically, the monitor will remain within the factory-calibrated accuracy indefinitely and no calibration is required. Complex software algorithms adjust for temperature drift, IR source aging, and pressure changes in order to keep the unit within factory accuracy specifications.*

Calibration Procedure

The calibration factor is determined by sampling a known dilution of ammonia gas. The sample must be prepared to less than half the desired accuracy and the concentration must be corrected for ambient temperature and pressure at the time of measurement.

Calibration is best performed at or near full scale, it can however, be done at any concentration and ideally in the range where maximum accuracy is desired down to, but not below, 100 ppm.

A cylinder of a certified calibration gas must be used to ensure sampling occurs at ambient conditions. A minimum sample size of 5 liters is required.

The AGMSZ should be operating for at least one hour prior to performing a calibration.

Prepare the AGMSZ for sampling by using the **CAL** function to set the calibration factor to 1.000. Also, use the **LOG INT** function to set the log interval to 1 minute.

With the AGMSZ operating normally, connect the gas-sample bag directly to the gas-inlet port and allow the monitor to sample the entire bag. When sampling is complete, view the logged ppm values using the **PPM LOG** function. If the bag was large enough for multiple samples, average the most stable ones. The new calibration factor is computed by dividing the known gas concentration value by the measured value. Typically this number will be between 0.95 and 1.05. Use the **CAL** function as described below to enter the new calculated calibration factor

Adjusting Calibration Factor

From the **Data Display** screen, use the **Keypad** buttons to place the arrow (>) on the display next to the **CAL** function. Then press **ENTER** to display the **Calibration** screen.

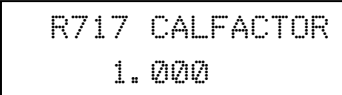

```
R717 CALFACTOR
  1.000
```

With the **Calibration** screen displayed, use the **Keypad** buttons to enter the new calibration factor.

Press **ENTER** to save this value.

Maintenance

Warnings and Cautions



WARNING: *Always disconnect AC power before working inside the monitor.*

CAUTION: *When working inside the monitor, be very careful not to dislodge any electrical wiring or pneumatic tubing. The AGMSZ contains sensitive electronic components that can be easily damaged. Be careful not to touch or disturb any of these components.*

Hydrophobic Filters

Hydrophobic Filters (Page 8) located in both the gas-sample and purge lines prevent water from entering the IR detector. A zone flow fault will occur (fault code <0800>) if the gas-sample filter becomes blocked, while a purge flow fault will occur (fault code <1000>) if the purge filter becomes blocked. Replace the appropriate filter as required (P/N 07-1650).

Servicing Air Lines & Termination Filters

The gas-sample line and the optional purge and exhaust lines should be periodically checked for obvious signs of kinks, damage, and contamination. Replace the tubing as required (P/N 304-2742).

The gas-sample line and purge-line termination filters prevent dust and dirt from entering the monitor. Both of these filters should be periodically checked and replaced when there are obvious signs of contamination. A zone flow fault will occur (fault code <0800>) if the gas-sample line filter becomes blocked, while a purge flow fault will occur (fault code <1000>) if the purge-line filter becomes blocked. To service the filter, simply remove it from the line and replace it with a new one (P/N 3015-3420).

Fuses

The AGMSZ is protected from electrical damage by two, 1 A, 250 V, type “F” fuses (Page 8). Carefully remove the fuses from their fuse clips and visually inspect each fuse for damage. Replace the fuses as required (P/N 04-2620).

Clock Battery

The Clock Battery (Page 8) maintains the correct date and time when AC power is not applied to the monitor. Replace this battery about every 2 years (P/N 204-0020).

Sample Pump

The Sample Pump (Page 8) draws the gas sample into the monitor, through the IR detector, and discharges the sample out the monitor’s exhaust port. When replacing the pump, remove its inlet and outlet tubing, disconnect the AC power wires from the pump itself, and remove pump from monitor. Install a new sample pump (P/N 3015-4239).

Replacement Parts & Optional Accessories

Replacement Parts

Item Description	Part Number
AGMSZ, complete assembly	3015-4280
Battery, Panasonic BR2032, 3 V	204-0020*
Filter, Hydrophobic	07-1650
Filter, Termination (gas-sample & purge lines).....	3015-3420
Fuse, 1.0 A, 250 V, Type "F"	04-2620
Pump	3015-4239
Tubing, ¼" OD (specify length when ordering)	304-2742

* **WARNING:** To preserve agency approvals and maintain the safety integrity of the monitor, the battery must be replaced with the specified Bacharach replacement part.

Optional Accessories

Item Description	Part Number
120 VAC Surge Protector.....	3015-4121
230 VAC Surge Protector.....	3015-4122
4–20 mA Surge Protector.....	3015-4123
Audible Alarm, 120 VAC.....	3015-3070
Audible/Visual Alarm, 120 VAC.....	3015-3076
Visual Alarm, 120 VAC.....	3015-3069

Service Centers

Replacement parts and service can be obtained by contacting one of the following Bacharach Service Centers.

United States

California

7281 Garden Grove Blvd.,
Suite H
Garden Grove, CA 92841
Phone: 714-895-0050
Fax: 714-895-7950
Email: calservice@bacharach-inc.com

New Jersey

7300 Industrial Park
Rte. 130, Bldg. 22
Pennsauken, NJ 08110
Phone: 856-665-6176
Fax: 856-665-6661
Email: njservice@bacharach-inc.com

Pennsylvania

621 Hunt Valley Circle
New Kensington, PA 15068
Phone: 724-334-5051
Fax: 724-334-5723
Email: help@bacharach-inc.com

Canada

Bacharach of Canada, Inc.
250 Shields Court Unit #3
Markham, Ontario L3R 9W7 Canada
Phone: 905-470-8985
Fax: 905-470-8963
Email: bachcan@idirect.com

México

Bacharach de México
Playa Regatas No. 473 Tercer Piso
Col. Militar Marte
Delegación Iztacalco, 08830
México D.F. México
Phones: +52-555-634-7740
+52-555-634-7741
FAX: +52-555-634-7738
Email: bacharach@prodigy.net.mx

Europe

European Headquarters

Bacharach Instruments
Sovereign House, Queensway
Leamington Spa
Warwickshire CV31 3JR
United Kingdom
Phone: +44-1926-338111
Fax: +44-1926-338110
Email: sales@bacharach-europe.com

Sales / Service Center - Denmark

Bacharach Instruments Int'l
P.O. Box 44
39 Lindegade
DK 6070 Christiansfeld Denmark
Phone: +45-74-563171
Fax: +45-74-563178
Email: mail@bacharach.dk

Specifications

- Product Type..... Single zone infrared monitoring system for low level continuous monitoring of ammonia refrigerant gas used in most commercial refrigeration systems
- Gas..... Ammonia, NH₃, R-717
- Measuring Range..... 25 to 10,000 ppm
- Detector Type..... Infrared, Non-Dispersive
- Coverage..... Single zone
- Monitoring Distance..... Up to 50 ft (15.2 m) maximum gas-sample line length
- Front Panel 3 Indicator lights:
MONITOR ON – Green light ON when the unit is operating normally, or flashing during warm-up
SYSTEM FAULT – Yellow light ON when there is a system fault
ALARM – Red light ON when the gas level is above an alarm setting
- Alarms..... Four SPDT relays are provided (rated 3 A, 240 VAC):
 three assigned to ppm level alarms – one assigned to system faults
 Internal audible alarm programmable for any of the following conditions:
 OFF, Any Alarm, System Fault, Leak Alarm, Spill Alarm, Evacuation Alarm, Monitor Stopped
- Sensitivity 1 ppm
- Accuracy ±10 ppm from 25 to 100 ppm, or ±10% of reading from 100 to 10,000 ppm
- Response Time/Flow Rate... Dependent on gas-sample line length; 0.25" OD x 0.17" ID tubing:

Gas-Sample Line Feet (Meters)	Response Time Seconds	Flow Rate ml/min
0 (0)	9	675
10 (3.0)	13	664
20 (6.1)	17	653
30 (9.1)	22	642
40 (12.2)	26	631
50 (15.2)	30	620

- Warm-up Time..... 15 minutes
- Temperature Drift ±0.8% of reading per degrees C
- System Noise Less than 40dB(A) at 10 ft (3 m)
- Conditioned Signal 4–20 mA current loop
- Power Safety Mode..... Fully automatic system reset; all programmed parameters retained
- Operating Temperature 32 to 122°F (0 to 50°C)
- Storage Temperature –4 to 122°F (–20 to 50°C)
- Ambient Humidity..... 5 to 90% RH (non-condensing)
- Altitude Limit 6,562 ft (2,000 m)
- AC Power..... 100 to 240 VAC, 50/60 Hz
- Power Consumption 15 Watts
- Size/Weight 7.4"H x 15"W x 3.3"D / 5 lbs.
- Certification UL 61010A-1; CAN/CSA 22.2 No. 1010-1B:1997;
 CE Mark (see inside front cover)
- Warranty..... 2 Years from date of shipment

Notes:



Headquarters:
621 Hunt Valley Circle, New Kensington, PA 15068
PH: 724-334-5000 • Toll Free: 800-736-4666 • FAX: 724-334-5001
Website: www.bacharach-inc.com • E-mail: help@bacharach-inc.com