

OWNER'S MANUAL

CULTIVATOR

Model No.
193-984A-000

**PARTS LIST FOR CULTIVATOR
MODEL NO. 193-984A-000**

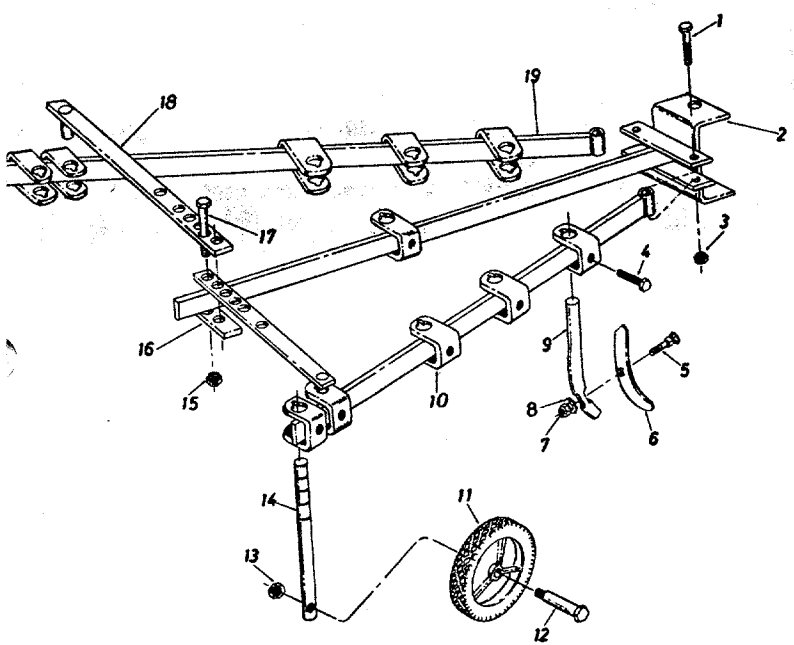

REF. NO.	PART NO.	QUANT.	DESCRIPTION
1	43054	2	Hex Bolt 3/8-16 x 2.50" Lg. (Grade 5)
2	62342	1	Assembly Hitch Bar
3	43082	2	Hex L.-Nut 3/8-16 Thd.*
4	43020	11	Hex Bolt 1/2-13 x 1.50" Lg. (Grade 5)
5	43058	7	Plow Bolt
6	43016	7	Cultivator Point
7	43015	7	Hex Nut 3/8-16 Thd.*
8	43003	7	L.-Wash. 3/8" I.D.*
9	23040	7	Rod Shank
10	62026	11	Assembly Clamp
11	43021	2	Wheel
12	43029	2	Shoulder Bolt .489" Dia. x 1.450
13	43082	2	Hex L.-Nut 3/8-16 Thd.*
14	23042	2	Rod Gauge Wheel
15	43262	2	Hex L.-Nut 1/2-13 Thd.*
16	23325	1	Plate - Tie Bar
17	43634	2	Hex Bolt 1/2-13 x 3.00" Lg. (Grade 5)
18	62344	2	Assembly Adjustment Bar
19	62343	2	Assembly Side Bar

ASSEMBLY INSTRUCTIONS

(See illustration above)

- 1. Lay all the loose parts in carton out on floor or work bench.
- 2. Separate all of the hardware (nuts and bolts) into groups.
- 3. Preassemble eleven clamps (Ref. 10) and hex bolts 1/2" x 1.50" long (Ref. 4). Thread bolts into clamps until one thread shows through weld nut.
- 4. Preassemble two wheels (Ref. 11), wheel rods (Ref. 14), shoulder bolts (Ref. 12) and hex lock nuts (Ref. 13). Place shoulder bolt through wheel and thread into wheel rod. Secure shoulder bolt with hex lock nut.

- 5. Preassemble seven shank rods (Ref. 9) and cultivator points (Ref. 6). Secure points to shanks with plow bolts (Ref. 5), lock washers (Ref. 8) and hex nuts (Ref. 7).
- 6. Place the tubes on the two side bars (Ref. 19) in between the welded brackets on hitch bar assembly (Ref. 2).
- 7. Place hex bolts 3/8 x 2-1/2" long (Ref. 1) through hitch bar and tubes on the end of the side bars. Start hex nuts (Ref. 3) by hand (Do Not Tighten).
- 8. Place one clamp (Ref. 10) on each side bar (open part of clamp faces the center of cultivator).
- 9. Place two adjustment bars (Ref. 18) with the weld pin end down through clamps. Overlap the other ends on hitch bar so that the two end holes line up with each other.

10. Secure the ends of adjustment bars by placing two 1/2 x 3" long bolts (Ref. 17) down through adjustment bars (one bolt on each side of hitch bar), tie bar (Ref. 16) and hex lock nuts (Ref. 15).
11. Tighten bolts and nuts at the front of hitch bar and bolts on clamps.
12. Place one clamp (Ref. 10) on center of hitch bar. Place one preassembled shank rod up through clamp and tighten hex bolt on clamp.
13. Place two clamps on ends of side bars. Next, place preassembled wheel rods up through clamps. Tighten hex bolts on clamps.
14. Assemble the remaining six preassembled shank rods and clamps.

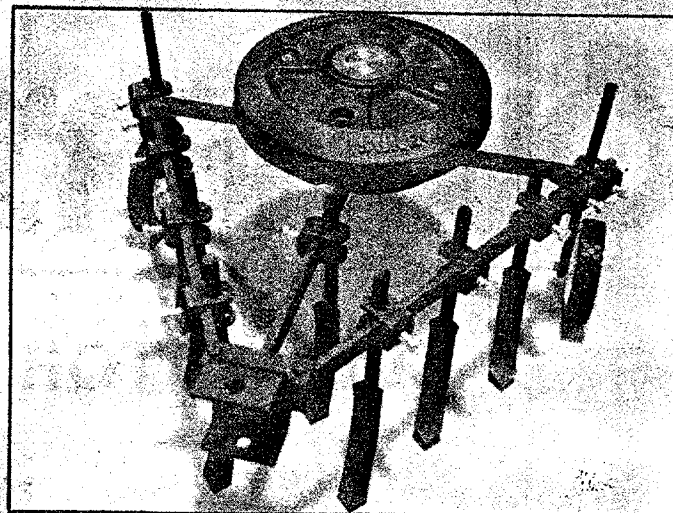

FIGURE 1

OPERATING INSTRUCTIONS

Cultivator may be used to straddle the row or work between rows. The hex bolts at clamps and bolts at adjustment bars allow widening or narrowing of cultivator frame for different row widths. By sliding the clamps forward on side bars and moving the adjustment bars so they overlap (five holes), you can narrow the cultivator frame. The cultivator points and shanks may be moved up or down, forward or back by loosening the hex bolts on clamps, repositioning as desired and tightening hex bolt. The gauge wheels may be adjusted up or down in the same manner.

To improve cultivator penetration and stability, it is suggested you add a weight to top of cultivator frame. See figure 1. A common concrete block maybe used or you may purchase weight, Part No. 723-0359.