

FG6RL Series

High Efficiency / Direct Vent or Non Direct Vent

Condensing Downflow Gas Furnace

Induced Draft - 92.1 AFUE Input 40,000 - 120,000 Btuh

The high efficiency downflow gas furnace may be installed free standing in a utility room, or enclosed in an alcove or closet. The extended flush jacket provides a pleasing "appliance appearance." Design certified by the Canadian Standards Association (CSA). The product is truly designed with the contractor and the consumer in mind.

FEATURES & BENEFITS

- **Best warranty in the business** -
 - A lifetime warranty on the heat exchanger
 - 8 Year Limited Parts and 5 Year Quality Pledge
- **100% fired and tested** - All units and each component (both mechanical and electrical) are tested on the manufacturing line.
- **Best packaging in the industry** - Unique design assures product will arrive to the homeowner dent free.
- **Clean and quiet operation** - Due to the unique design of in-shot burners, location of inducer, return air vents, and use of insulation.
- **Fixed 30 second blower delay** at burner start-up assures a warm duct temperature at furnace start-up. Adjustable blower off settings (60, 120, 160 and 180 seconds).
- **Fixed 30 second post purge** increases life of heat exchanger.
- **SmartLite™ Control Board** — Provides extended life to ignitors in furnaces using hot surface ignition technology. Programmed to learn the heat-up characteristics of the ignitor, then adapt the ignition time to the characteristics of the furnace so the ignitor is energized appropriately.
- **Dependable, hot surface ignitor** - Innovative application of an appliance type ignitor with a 20 year history of reliability, assures no callbacks because of handling.
- **Color coded wire harness** - Designed to fit the components, all with quick-connect fittings for ease of service and replacement.
- **Tubular primary heat exchanger** - Heavy gauge aluminized steel heat exchanger assures a long life.
- **Stainless steel secondary heat exchanger** assures long life.
- **90-second fixed cooling cycle blower-off delay (TDR)** increases cooling performance when matched with a NORDYNE coil.
- **Approved for direct vent furnace, category IV venting system** – May be vertically or horizontally vented using either a one-pipe or two-pipe system for maximum flexibility in installation.
- **Fully insulated blower cabinet** for quiet operation.
- **Multi-speed direct drive blower** - Designed to give a wide range of cooling capacities. 40VA transformer included.
- **LP convertible** - Simple burner orifice and regulator spring change for ease of convertibility.
- **Diagnostic light flashes identify limit failure, pressure switch failure and improper ground and polarization** - for easy troubleshooting.
- **Incorporates integrated control board** with connections for electronic air cleaner, humidifier and twinning.
- **Factory installed drain system** for reliable performance.
- **Door design** enhances furnace appearance and uses screw fasteners for great fit and accessibility.
- **3 amp fuse** protection against high and low voltage shorts; protects transformer and control board.
- **Low voltage terminal board** for easy field wiring.
- **Components and Controls** - Designing quality into our products means selecting manufacturers that have a reputation for delivering high quality, dependable products.

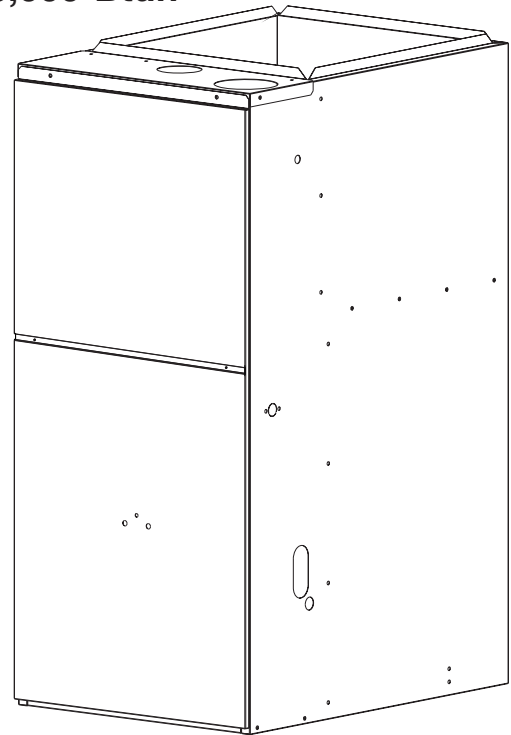

FEATURES

High Efficiency Downflow 90+ Gas Furnace

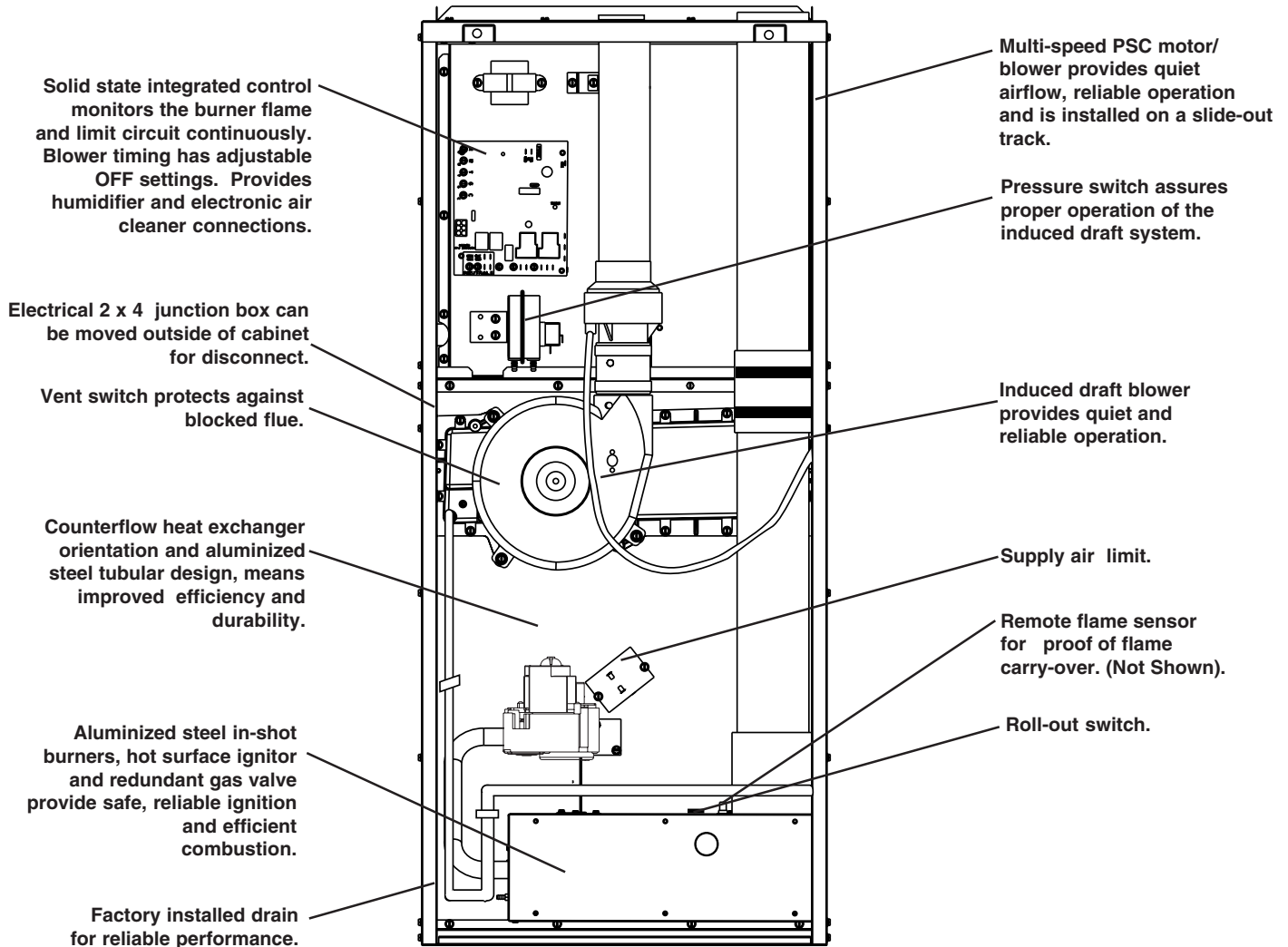

STANDARD EQUIPMENT

Direct vent; draft inducer; pressure switch; redundant main gas control; hot-surface ignition; timed ON/OFF blower controls (TDR); 40VA transformer for air conditioner application; limit controls; direct drive motor; all models can be converted to use L.P. (propane) gas. Factory approved kits *only* must be used and are available as an optional accessory from your NORDYNE distributor.

SPECIFICATIONS

FG6RL MODEL NUMBERS:	-040C-12A	-060C-12A	-080C-16B	-100C-16B	-120C-20C
Input-Btuh (a)	40,000	60,000	80,000	100,000	120,000
Heating Capacity - Btuh	36,000	56,000	74,000	93,000	112,000
AFUE	90+	92.1	92.1	92.1	92.1
Blower D x W	10 x 6	10 x 6	10 x 10	10 x 10	11 x 10
Motor H.P. -Speed -Type	1/3 - 3 - PSC	1/3 - 3 - PSC	1/2 - 4 -PSC	1/2 - 4 -PSC	3/4 - 4 -PSC
Motor FLA	7.0	7.0	9.0	9.0	11.1
Maximum Ext. SP - In. W.C.	0.5	0.5	0.5	0.5	0.5
Temperature Rise Range - °F	35 - 65	40 - 70	45 - 75	50 - 80	45 - 75

Note: All models are 115V, 60 Hz. Gas Connections are 1/2" N.P.T. AFUE = Annual Fuel Utilization Efficiency

(a) Ratings to 2,000 ft. Over 2,000 ft. reduce 4% for each 1,000 ft. above sea level.

DIMENSIONS

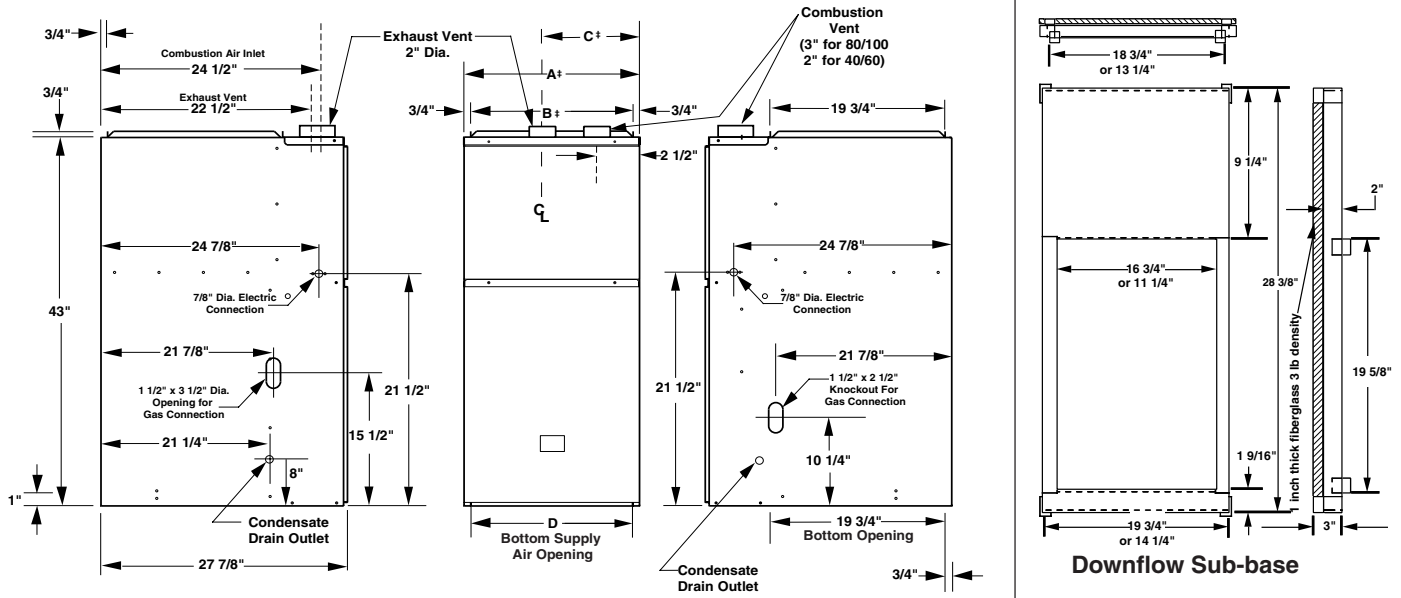

MODEL NUMBER FG6RL-	Furnace Input (Btu/Hr)	Dimensions				Shipping Weights (lbs)
		A (in.)	B (in.)	C (in.)	D (in.)	
040C-12A	40,000	14 1/4	12 3/4	4 5/8	11 3/4	135
060C-12A	60,000	14 1/4	12 3/4	4 5/8	11 3/4	135
080C-16B	80,000	19 3/4	18 1/4	10	17 1/4	174
100C-16B	100,000	19 3/4	18 1/4	10	17 1/4	185
120C-20C	120,000	22 1/2	21	12 1/2	21 1/8	209

Allow 36" minimum clearance for service.

BLOWER PERFORMANCE

Model Number *RL-	Heating Input (Btuh)	Motor Speed	Motor HP	External Static Pressure (Inches Water Column)															
				0.1		0.2		0.3		0.4		0.5		0.6		0.7		0.8	
				CFM	Rise	CFM	Rise	CFM	Rise	CFM	Rise	CFM	Rise	CFM	Rise	CFM	Rise	CFM	Rise
040C-12	40,000	High* Medium Low**	1/3	1280	-	1210	-	1180	-	1140	-	1090	-	1070	-	1030	-	990	-
				1140	-	1090	-	1060	-	1030	-	980	35	950	36	910	37	870	39
				875	39	835	41	820	41	805	42	780	43	770	44	760	45	750	45
060C-12	60,000	High* Medium Low**	1/3	1260	40	1190	43	1155	44	1120	45	1075	47	1030	49	980	52	940	54
				1120	45	1070	48	1040	49	1010	50	960	53	930	55	890	57	850	60
				855	59	815	62	800	64	780	65	760	67	730	70	710	-	690	-
080C-16	80,000	High* Med-High Med-Low** Low	1/2	1635	-	1585	-	1525	-	1460	46	1400	48	1330	51	1260	54	1180	57
				1435	47	1395	49	1350	50	1300	52	1255	54	1200	56	1150	59	1090	62
				1230	55	1200	56	1165	58	1130	60	1090	62	1050	65	1000	68	960	71
				1050	-	1035	-	1010	-	980	-	950	-	910	-	870	-	820	-
100C-16	100,000	High* Med-High** Med-Low Low	1/2	1600	53	1555	54	1500	56	1445	59	1380	61	1310	65	1240	68	1160	73
				1475	57	1435	59	1385	61	1335	63	1290	66	1240	68	1190	71	1130	75
				1320	-	1290	-	1250	-	1215	-	1170	-	1120	-	1070	-	1020	-
				1150	-	1130	-	1110	-	1075	-	1040	-	1000	-	950	-	890	-
120C-20	120,000	High* Med-High** Med-Low Low	3/4	2085	48	2034	49	1965	51	1909	52	1842	54	1779	56	1714	58	1631	61
				1924	52	1883	53	1836	55	1781	56	1728	58	1675	60	1613	62	1538	65
				1718	58	1671	60	1629	61	1612	63	1567	64	1510	66	1464	68	1412	72
				1501	66	1497	69	1461	66	1428	70	1397	72	1364	73	1316	-	1266	-

* Factory Set Cooling Speed
 ** Factory Set Heating Speed
 - Not Recommended

NOTES: 1. Airflow rates of 1800 CFM or more require two return air connections. Data is for operation with filter(s).
 2. Temperature rises in the table are approximate. Actual temperature rises may vary.
 3. Temperature rises and airflows for external static pressures greater than 0.5 are for reference only. These conditions are not recommended.

MODEL IDENTIFICATION CODE

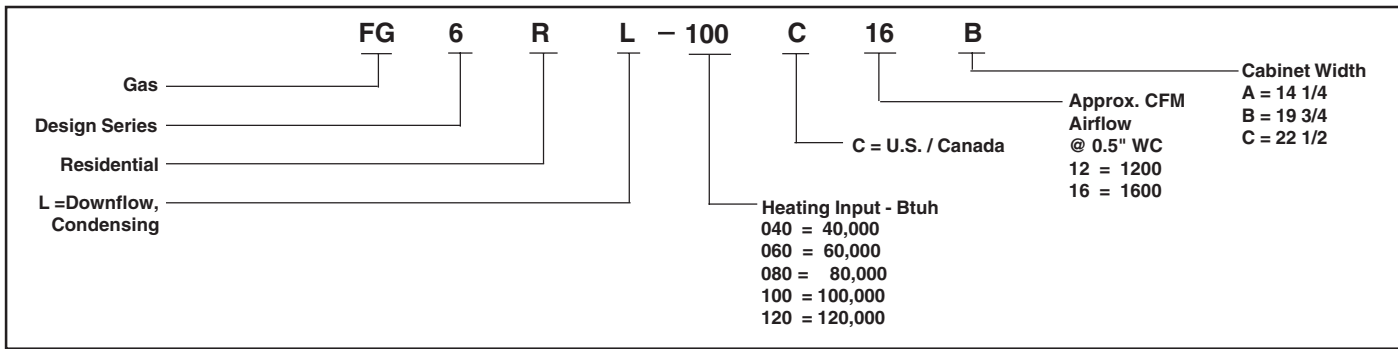

VENTING

All models are approved for vertical non direct (1 pipe) and direct (2 pipe) venting applications. See Vent Table below for specified sizes and allowable lengths.

VENT TABLE

APPLICATION	SINGLE PIPE LENGTH (ft.) with 1 long radius elbow**		DIRECT VENT, DUAL PIPE LENGTH (ft.) with 1 long radius elbow on each pipe**					
	Outlet 2"	Outlet 3"	Inlet/Outlet 2"	Inlet/Outlet 2"	Inlet/Outlet 3"	Inlet/Outlet 2"	Inlet/Outlet 3"	Inlet/Outlet 3"
Models 040	80	150	40	40	50	50	90	90
Models 060 & 080	60	150	30	30	35	35	90	90
Models 100 & 120	30	150	15	15	25	25	90	90

* NOTE:

1. Subtract 2.5 ft. for each additional 2" elbow and 3.5 ft. for each additional 3" elbow.
2. Two 45 degree elbows are equivalent to one 90° elbow.
3. One short radius elbow is equivalent to 2 long radius elbows.
4. Do not include termination elbows in calculation of vent length.
5. This table is applicable for elevations from sea level to 2000 ft. For higher elevations decrease vent pipe lengths by 8% per 1000 ft. of altitude.
6. Only the above pipe materials are approved for use with FG6 Condensing Furnaces.

ACCESSORY VENT KITS

Kit	Order Number
U.S. LP Conversion Kit (0 to 10,000 ft.)	904090A
Canadian LP Gas Conversion Kit (0 to 4,500 ft.)	904091A
Fossil Fuel Kit	914762
Downflow Sub-Base	A Cabinet 902974 B Cabinet 902677 C Cabinet 904108
Variable Speed Blower Kit For "A" Cabinets	904231
Variable Speed Blower Kit For "B" & "C" Cabinets	904075

Kit Description	2" PVC	3" PVC	4" PVC
Horizontal Exterior Vent Mounting Kit	9023730	9023750	9023760
Neutralizer Kit (all models)	9023770		



Westinghouse products are manufactured and distributed by NORDYNE.

® and Westinghouse are trademarks of Westinghouse Electric Corporation and used under license to NORDYNE.

213B-0506 (Replaces 213B-0504)

Before purchasing this appliance, read important energy cost and efficiency information available from your retailer. Specifications and illustrations subject to change without notice and without incurring obligations. Printed in U.S.A. (05/06)