

Think GAIA
For Life and the Earth

SANYO

Power Supply ICs, LED Driver ICs

2008-6

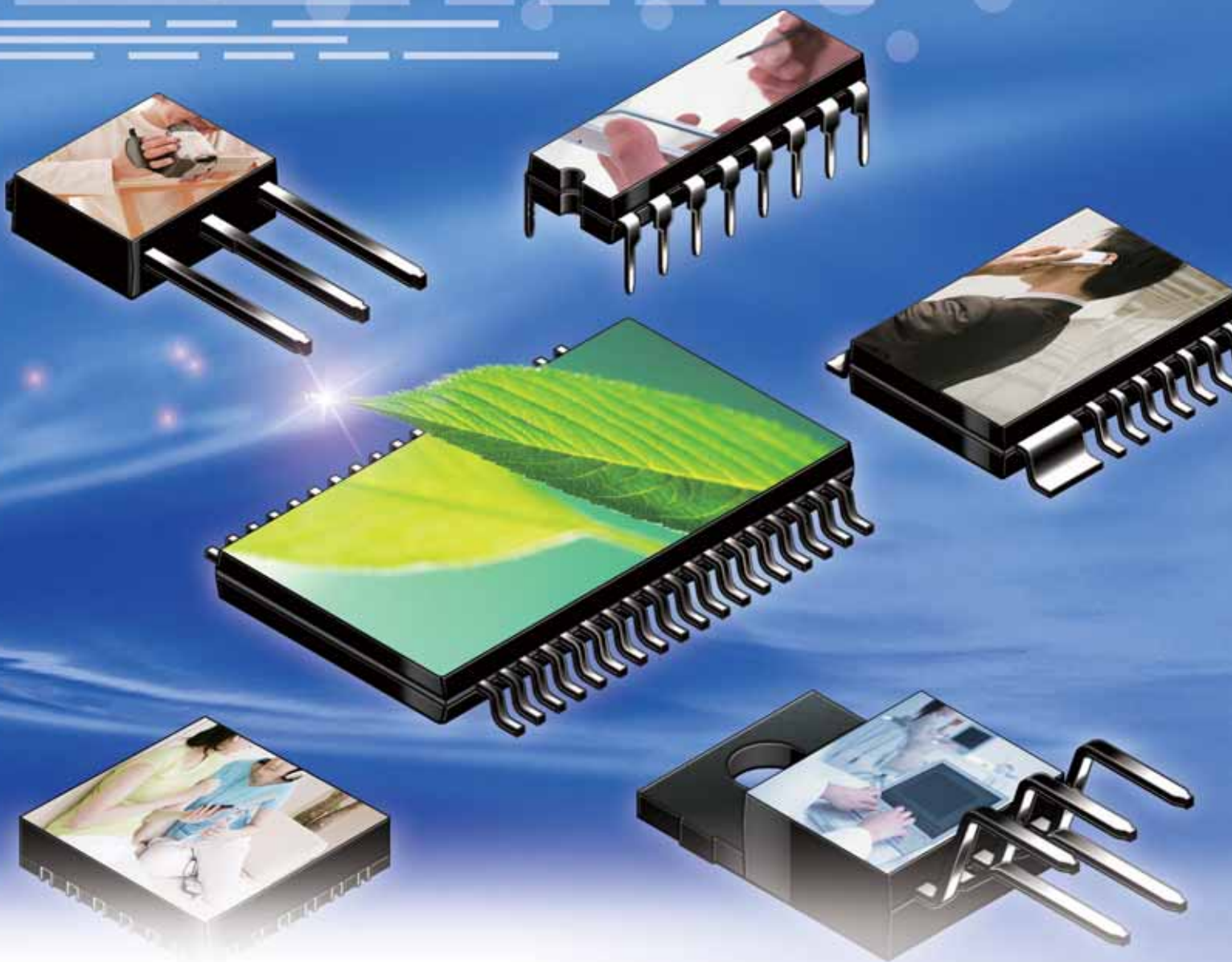

SANYO Semiconductor Co., Ltd.

Power Supply IC

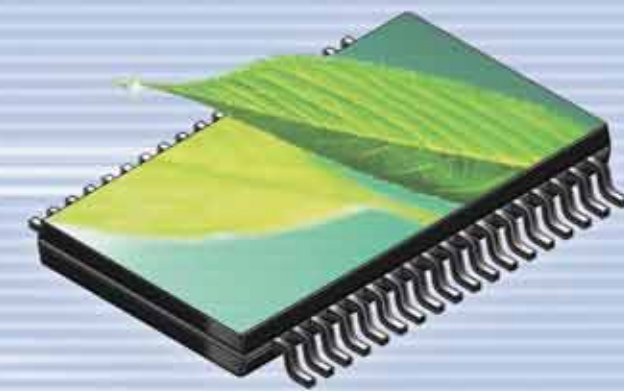

**For both analog and digital systems,
SANYO multifunction regulator IC products,
support our customers' creation of the new wave
of next generation in electronic products
by providing extensive functionality
and high reliability for all electronic devices.**

Contemporary electronic equipment requires a wide range of high-level technologies to remain viable in today's competitive market. For example, cell phones require technologies that achieve stable operation at low input voltages, improved efficiency, and further miniaturization in the power supply system. Similarly, digital home appliances not only requires low-power/low-voltage operation and improved efficiency, but also low power consumption in standby mode to meet energy usage requirements and the ability to meet high-frequency radiation standards.

We at SANYO Semiconductor makes a point of grasping these needs as early as possible and developing ICs contributing to achieve improved system development and high level of integration based on our rich experience in general-purpose product technologies.

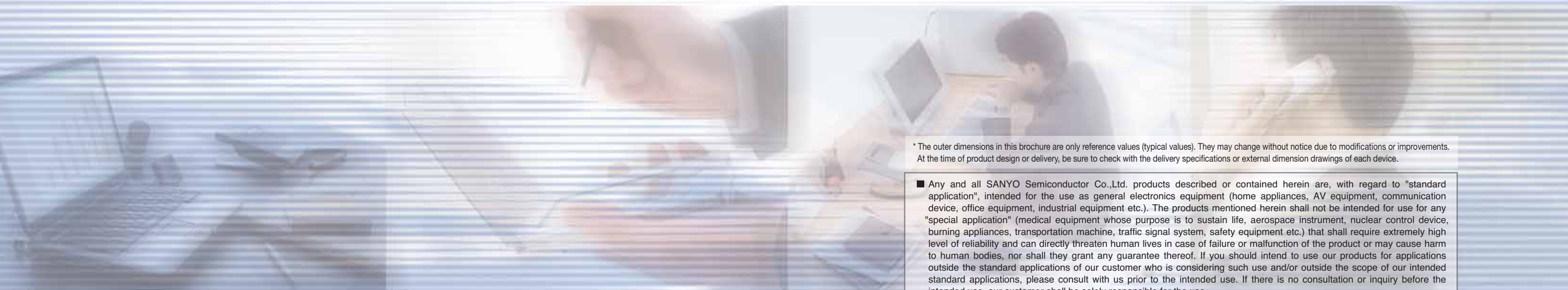

* The outer dimensions in this brochure are only reference values (typical values). They may change without notice due to modifications or improvements. At the time of product design or delivery, be sure to check with the delivery specifications or external dimension drawings of each device.

CONTENTS

◆ Product Lineup

• DC-DC Converter (Control) ICs -----3	• Series Power Supply ICs ----- 6 to 9
• DC-DC Converter (Control) ICs -----3 [Synchronous Rectification Type]	• Power Supply Switching ICs ----- 9
• AC-DC Converter (Control) ICs -----4	• Power ICs with a Watchdog Timer Function ----- 10
• Power Supply ICs ----- 4 for Single Lens Reflex Digital Cameras	• Dual-Protection ICs ----- 10
• Power Supply ICs for Surveillance Cameras --- 4	• Dual-Protection ICs ----- 10, 11 (for Rechargeable Lithium-ion Batteries)
• Power Supply ICs for Panels ----- 4	• Rechargeable Battery Charge Control ICs ----- 11
• System Power Supply ICs ----- 5 (for Portable Electronic Devices)	• Dedicated Reset Function ICs ----- 11
• System Power Supply ICs ----- 5 (for AV Electronic Devices)	• LED Driver ICs ----- 11

- Any and all SANYO Semiconductor Co.,Ltd. products described or contained herein are, with regard to "standard application", intended for the use as general electronics equipment (home appliances, AV equipment, communication device, office equipment, industrial equipment etc.). The products mentioned herein shall not be intended for use for any "special application" (medical equipment whose purpose is to sustain life, aerospace instrument, nuclear control device, burning appliances, transportation machine, traffic signal system, safety equipment etc.) that shall require extremely high level of reliability and can directly threaten human lives in case of failure or malfunction of the product or may cause harm to human bodies, nor shall they grant any guarantee thereof. If you should intend to use our products for applications outside the standard applications of our customer who is considering such use and/or outside the scope of our intended standard applications, please consult with us prior to the intended use. If there is no consultation or inquiry before the intended use, our customer shall be solely responsible for the use.
- Specifications of any and all SANYO Semiconductor Co.,Ltd. products described or contained herein stipulate the performance, characteristics, and functions of the described products in the independent state, and are not guarantees of the performance, characteristics, and functions of the described products as mounted in the customer's products or equipment. To verify symptoms and states that cannot be evaluated in an independent device, the customer should always evaluate and test devices mounted in the customer's products or equipment.
- SANYO Semiconductor Co.,Ltd. assumes no responsibility for equipment failures that result from using products at values that exceed, even momentarily, rated values (such as maximum ratings, operating condition ranges, or other parameters) listed in products specifications of any and all SANYO Semiconductor Co.,Ltd. products described or contained herein.
- SANYO Semiconductor Co.,Ltd. strives to supply high-quality high-reliability products, however, any and all semiconductor products fail or malfunction with some probability. It is possible that these probabilistic failures or malfunction could give rise to accidents or events that could endanger human lives, trouble that could give rise to smoke or fire, or accidents that could cause damage to other property. When designing equipment, adopt safety measures so that these kinds of accidents or events cannot occur. Such measures include but are not limited to protective circuits and error prevention circuits for safe design, redundant design, and structural design.
- In the event that any or all SANYO Semiconductor Co.,Ltd. products described or contained herein are controlled under any of applicable local export control laws and regulations, such products may require the export license from the authorities concerned in accordance with the above law.
- No part of this publication may be reproduced or transmitted in any form or by any means, electronic or mechanical, including photocopying and recording, or any information storage or retrieval system, or otherwise, without the prior written consent of SANYO Semiconductor Co.,Ltd.
- Any and all information described or contained herein are subject to change without notice due to product/technology improvement, etc. When designing equipment, refer to the "Delivery Specification" for the SANYO Semiconductor Co.,Ltd. product that you intend to use.
- Information (including circuit diagrams and circuit parameters) herein is for example only; it is not guaranteed for volume production.
- Upon using the technical information or products described herein, neither warranty nor license shall be granted with regard to intellectual property rights or any other rights of SANYO Semiconductor Co.,Ltd. or any third party. SANYO Semiconductor Co.,Ltd. shall not be liable for any claim or suits with regard to a third party's intellectual property rights which has resulted from the use of the technical information and products mentioned above.

Product Lineup

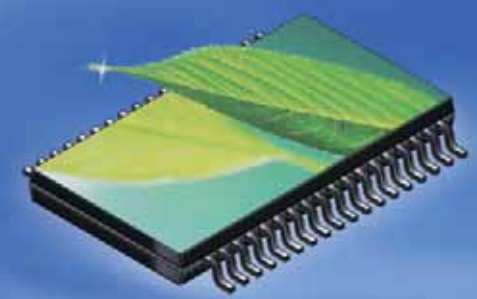

DC-DC Converter (Control) ICs

●: New products and
※: Development

Type No.	Type	Input voltage	Output voltage	Channels	Power stages	Package	P
LA5660M	Step up	1.8V to 14V	Programmable externally	1ch	External (NPN or NMOS)	MFP8(225mil)	
● LV5803M	Step down	4.5V to 18V	Programmable externally	1ch	Built in	MFP8(225mil)	13
※ LV5807MA	Step down	4.5V to 18V	Programmable externally	1ch	Built in	SOP8J(200mil)	
● LA5724M	Step down	4.5V to 28V	Programmable externally/0.6A	1ch	Built in	MFP8(225mil)	
● LA5744	Step down	4.5V to 28V	Programmable externally/3A	1ch	Built in	220-5HK	
● LA5744MP	Step down	4.5V to 28V	Programmable externally/3A	1ch	Built in	SMP5	
● LA5744TP	Step down	4.5V to 28V	Programmable externally/3A	1ch	Built in	TP5HFA	
● LA5774	Step down	4.5V to 28V	Programmable externally/3A	1ch	Built in	220-5H	12
● LA5774MP	Step down	4.5V to 28V	Programmable externally/3A	1ch	Built in	SMP5	12
● LA5779	Step down	4.5V to 28V	Programmable externally/3A	1ch	Built in	220-5H	12
● LA5779MP	Step down	4.5V to 28V	Programmable externally/3A	1ch	Built in	SMP5	12
● LA5779N	Step down	4.5V to 28V	Programmable externally/3A	1ch	Built in	220-5HK	
● LA5734MP	Step down	4.5V to 32V	Programmable externally/3A	1ch	Built in	SMP5	12
● LA5735M	Step down	4.5V to 32V	Programmable externally/0.6A	1ch	Built in	MFP8(225mil)	
※ LA5755	Step down	4.5V to 32V	Programmable externally	1ch	Built in	TO220	
※ LA5756	Step down	4.5V to 32V	Programmable externally	1ch	Built in	TO220	
※ LV5745GP	Step down	4.5V to 6V	Programmable externally	3ch	External (PMOS)	VCT28(3.0×3.0)	
● LV5781	Step down	4.5V to 6V	Programmable externally	1ch	Built in	HSSOP14(225mil)	
LA5771MP	Step down	5.5V to 28V	3.3V/3A	1ch	Built in	SMP5	12
● LA5771	Step down	5.5V to 32V	3.3V/3A	1ch	Built in	220-5H	12
LA5772MP	Step down	7V to 28V	5V/3A	1ch	Built in	SMP5	12
● LA5772	Step down	7V to 32V	5V/3A	1ch	Built in	220-5H	12
※ LV5746V	Step down	8V to 22V	Programmable externally	2ch	External (PMOS)	SSOP20(225mil)	
● LA5777	Step down	8V to 28V	5V/3A	1ch	Built in	220-5H	12
● LA5777MP	Step down	8V to 28V	5V/3A	1ch	Built in	SMP5	12
※ LV5806MA	Step down	8V to 28V	Programmable externally	1ch	Built in	SOP8J(200mil)	
※ LV5808M	Step down	8V to 28V	Programmable externally	1ch	Built in	MFP8(225mil)	
● LV5743V	Step down	8V to 33V	Programmable externally	2ch	External (PMOS)	SSOP16(225mil)	
LA5664M	Step up/down	4V to 5.6V	5V/250mA	1ch	Built in	MFP14S(225mil)	
LV5051T	Step up/down+ Linear regulator	1.5V to 4.4V 2V to 8.0V	2.5V (Step up/down) 2.8V/3.9A (Linear)	3ch	Built in	TSSOP24(225mil)	
● TN5D41A	Step down	10V to 40V	5V/5A	1ch	Built in (PMOS)	TO-220FI5H-HB	14
※ TN8D41A	Step down	10V to 40V	5V/8A	1ch	Built in (PMOS)	TO-220FI5H-HB	14
● TN5D51A	Step down	20V to 48V	12V/5A	1ch	Built in (PMOS)	TO-220FI5H-HB	14
※ TN8D51A	Step down	20V to 48V	12V/8A	1ch	Built in (PMOS)	TO-220FI5H-HB	14
※ TN5D61A	Step down	30V to 48V	24V/5A	1ch	Built in (PMOS)	TO-220FI5H-HB	14

DC-DC Converter (Control) ICs [Synchronous Rectification Type]

●: New products and
※: Development

Type No.	Type	Input voltage	Output voltage	Channels	Power stages	Package	P
● LV5044V	Step down	7.5V to 16V 4.5V to 6V	Programmable externally	2ch	External (NMOS)	SSOP30(275mil)	
● LV5050V	Step down	7.5V to 16V 4.5V to 6V	Programmable externally	1ch	External (NMOS)	SSOP20(225mil)	15
※ LV5747TT	Step down	8V to 42V	Programmable externally	1ch	External (NMOS)	MSOP12(150mil)	
※ LV5749V	Step down	8V to 42V	Programmable externally	1ch	External (NMOS)	SSOP16(225mil)	
※ LV5741	Step down	8V to 42V	Programmable externally	1ch	External (NMOS)	DIP16(300mil)	

AC-DC Converter (Control) ICs

Type No.	Package	Functions	V _{CC} (V)	Features	P
LA5648	DIP8(300mil)	RCC/separately-excited fly-back AC-DC converter controller	30	UVLO, primary side PbyPOCP, secondary side timer type OCP	16

Power Supply ICs for Single Lens Reflex Digital Cameras

●: New products and
※: Development

Type No.	Type	Input voltage	Output voltage	Channels	Power stages	Package	P
LA5680T	Mixed step up/ step down	1.5V to 12V	Programmable externally	6ch (Step up 4, down 2)	External (NPN, PNP or NMOS, PMOS)	TQFP48J(7×7)	
● LA5683T	Mixed step up/ step down	1.8V to 8V	Programmable externally	4ch (Step up 2, down 2)	External (NPN, PNP or NMOS, PMOS)	TSSOP36(275mil)	
LA5679T	Mixed step up/ step down	1.8V to 11V	Programmable externally	3ch (Step up 1, down 2)	External (NPN, PNP or NMOS, PMOS)	TSSOP36(275mil)	
LA5669T	Multiple power supply	1.8V to 11V	Programmable externally	3ch	External	TSSOP36(275mil)	
● LV5603T	Multiple power supply	3V to 15V	Programmable externally	6ch (Step up 2, down 4)	External	TQFP48J(7×7)	17
※ LV5655	Multiple power supply	3V to 15V	Programmable externally	3ch (Step up 1, down 2)	External	SSOP24(225mil)	18
● LV5604T	Multiple power supply	3V to 15V	Programmable externally	8ch (Step up 3, down 5)	External	TQFP64J(7×7)	19

Power Supply ICs for Surveillance Cameras

●: New products and
※: Development

Type No.	Type	Input voltage	Output voltage	Channels	Power stages	Package	P
● LA5795T	Charge pump step-up	13.5V to 28V	Programmable externally	1ch	Built in	MSOP10(150mil)	
● LA5797M	Charge pump step-up	7.5V to 28V	Programmable externally	1ch	Built in (External diode)	MFP8(225mil)	
※ LV5606LP	± Charge pump step-up	3V to 3.45V	Programmable externally	2ch	Built in	VQLP32(4.0×4.0)	
※ LV5606V	± Charge pump step-up	3V to 3.45V	Programmable externally	2ch	Built in	SSOP30(275mil)	
● LV5608LP	± Charge pump step-up	3V to 3.45V	15V, -7.5V	2ch	Built in	VCT24(3.5×3.5)	
※ LV56081GP	± Charge pump step-up	3V to 3.45V	15V, -5.5V	2ch	Built in	VCT24(3.5×3.5)	
● LV5609LP	V driver for CCD	Ratings are listed on separate datasheet		5ch	Built in	VCT24(3.5×3.5)	
● LV5609V	V driver for CCD	Ratings are listed on separate datasheet		5ch	Built in	SSOP20(225mil)	

Power Supply ICs for Panels

●: New products and
※: Development

Type No.	Type	Input voltage	Output voltage	Channels	Power stages	Package	P
※ LA5661M	Backlight inverter	1.8V to 14V	Programmable externally	1ch	External	MFP10S(225mil)	
● LA5663V	Phase control voltage inverter	4.5V to 23V	Programmable externally (Current)	1ch	External	SSOP24(275mil)	

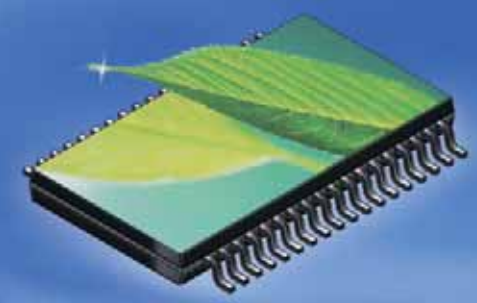

System Power Supply ICs (for Portable Electronic Devices)

●: New products

Type No.	Regulator output voltage/current				Absolute maximum ratings		Package	Functions/Features	P
	1	2	3	4	Input voltage (V)	Total power dissipation (W)			
LA5160AM	5V/100mA				40	0.8	MFP8(225mil)	Low consumption current at output-off time with built-in ON/OFF function.	
LV5105FN	2.8V/150mA	2.6V/100mA	2.85V/50mA	3V/50mA	5.9	0.44	VQFN48(7×7)	Built-in reset circuit × 2, 3-color LED driver, front LED driver, and microphone bias output.	
● LV5103LP	1	2	3	4	3.2 to 4.5	1.1*	VQLP40(5.0×5.0)	Built-in step-down DC-DC converter × 1, series regulator × 8, and short-circuit protection circuit *Ratings mounted on board: 40mm×50mm×0.8mm, Glass epoxy 4-layer (2S2P) board	
	1.5V/30mA	2.85V/200mA	2.85V/150mA	3.1V/450mA					
	5	6	7	8					
	3.3V/150mA	1.5V/200mA	1.8V/150mA	1.2V/500mA					

System Power Supply ICs (for AV Electronic Devices)

Type No.	Regulator output voltage/current					Absolute maximum ratings		Package	Functions/Features			P
	1	2	3	4	5	Input voltage (V)	Total power dissipation (W)		ON/OFF function	Reset output	Notes	
LA5632	3.3V/60mA	3.3V/150mA	5V/1000mA	5V/100mA		14	2.3	SIP12H	●	●	With power ON/OFF detection circuit.	
LA5643	3.5V/150mA	5V/1000mA	5V/100mA			14	2.0	SIP13H		●		
LA5624H	1	2	3	4	5	24	2.01	HSOP28HC (375mil)	●	●	10V regulator (when used with external PNP transistor) with standby function (on/off control). * Within ASO of external TR	
	5V/50mA	10V/*	8V/100mA	8V/30mA	8V/150mA							
	6	7	8	9	10							
	8V/100mA	5V/100mA	5V/300mA	SW/100mA	SW/100mA							
	OP1-C/10mA	OP2-C/10mA	OP3-C/10mA	OP4-C/10mA								
LA5635H	1	2	3	4	5	24	2.01	HSOP28HC (375mil)	●	●	10V regulator (when used with external PNP transistor) with standby function (on/off control). * Within ASO of external TR	
	5V/50mA	10V/*	8V/200mA	8V/30mA	8V/150mA							
	6	7	8	9	10							
	8V/100mA	5V/100mA	5V/300mA	SW/100mA	SW/500mA							
	OP1-C/10mA	OP2-C/10mA	OP3-C/10mA	OP4-C/10mA								
LA5613	5.1V/700mA	SW/300mA				14	1.7	SIP10F	●		11.3V/0.3A ripple filter switching regulator control amplifier built in.	
LA5601	5.2V/250mA	3.4V/10mA				15	1.0	DIP10S (300mil)	●	●	Built-in driver	
LA5617	7.5V/500mA	-7.5V/-500mA				±18	2.0	SIP10F	●		±Voltage tracking regulator	
LA5605	7.5V/500mA	9V/60mA	5V/10mA			24	2.0	SIP13H			Built-in AC standby and power detection functions.	
LA5606N	15.7V/350mA	12V/200mA	9V/150mA	5V/500mA		35	4.3	SIP14H	●			

Series Power Supply ICs

Type No.	Type	Output Current (A)	Output voltage (V)																				Absolute maximum ratings		Package	Features	P			
			1.8	2	2.5	3	3.3	3.4	3.5	4	5	6	7	8	9	10	12	15	18	20	24	Input voltage (V)	Total power dissipation (W)							
LA5002M	Positive voltage	0.06	●																					12	0.3	MFP8 (225mil)	2V low-saturation voltage regulator, 2V output voltage, 60mA output current, low-saturation (0.2V typ) series regulator, RF noise suppression			
LA5003	Positive voltage	0.06			●																			12	0.56	SIP4H	3V low-saturation voltage regulator, 3V output voltage, 60mA output current, low-saturation (0.2V typ) series regulator, RF noise suppression			
LA5003M	Positive voltage	0.06			●																			12	0.3	MFP8 (225mil)	3V low-saturation voltage regulator, SOP (MFP) version of LA5003			
LA5004	Positive voltage	0.06								●														12	0.56	SIP4H	4V low-saturation voltage regulator, 4V output voltage, 60mA output current, low-saturation (0.2V typ) series regulator, RF noise suppression			
LA5004M	Positive voltage	0.06								●														12	0.3	MFP8 (225mil)	4V low-saturation voltage regulator, SOP (MFP) version of LA5004			
LA5005	Positive voltage	0.06												●										12	0.56	SIP4H	5V low-saturation voltage regulator, 5V output voltage, 60mA output current, low-saturation (0.2V typ) series regulator, RF noise suppression			
LA5005M	Positive voltage	0.06												●										12	0.3	MFP8 (225mil)	5V low-saturation voltage regulator, SOP (MFP) version of LA5005			
LA5006M	Positive voltage	0.06													●									16	0.3	MFP8 (225mil)	6V low-saturation voltage regulator, 6V output voltage, 60mA output current, low-saturation (0.2V typ) series regulator, RF noise suppression			
LA5008M	Positive voltage	0.06																		●				16	0.3	MFP8 (225mil)	8V low-saturation voltage regulator, 8V output voltage, 60mA output current, low-saturation (0.2V typ) series regulator, RF noise suppression			
LA5009M	Positive voltage	0.06																					●		16	0.3	MFP8 (225mil)	9V low-saturation voltage regulator, 9V output voltage, 60mA output current, low-saturation (0.2V typ) series regulator, RF noise suppression		
LA5010M	Positive voltage	0.06																					●		16	0.3	MFP8 (225mil)	10V low-saturation voltage regulator, 10V output voltage, 60mA output current, low-saturation (0.2V typ) series regulator, RF noise suppression		
L88M05T	Positive voltage	0.5																							18	1.0	TP3H	5V low-saturation voltage regulator, 5V output voltage, 0.5A output current, 0.4V (typ) minimum I/O voltage drop		
L88M06T	Positive voltage	0.5																							18	1.0	TP3H	6V low-saturation voltage regulator, 6V output voltage, 0.5A output current, 0.4V (typ) minimum I/O voltage drop		
L88M09T	Positive voltage	0.5																						●		18	1.0	TP3H	9V low-saturation voltage regulator, 9V output voltage, 0.5A output current, 0.4V (typ) minimum I/O voltage drop	
L88M12T	Positive voltage	0.5																						●		18	1.0	TP3H	12V low-saturation voltage regulator, 12V output voltage, 0.5A output current, 0.4V (typ) minimum I/O voltage drop	

Continued on next page.

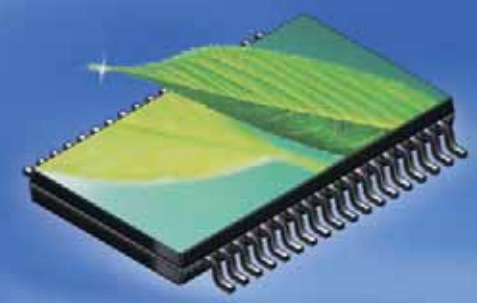

Series Power Supply ICs Continued from preceding page.

Type No.	Type	Output Current (A)	Output voltage (V)																						Absolute maximum ratings		Package	Features	P
			1.8	2	2.5	3	3.3	3.4	3.5	4	5	6	7	8	9	10	12	15	18	20	24	Input voltage (V)	Total power dissipation (W)						
L88M33T	Positive voltage	0.5					●																	18	1.0	TP3H	3.3V low-saturation voltage regulator, 3.3V output voltage, 0.5A output current, 0.4V (typ) minimum I/O voltage drop		
L88M35T	Positive voltage	0.5						●																18	1.0	TP3H	3.5V low-saturation voltage regulator, 3.5V output voltage, 0.5A output current, 0.4V (typ) minimum I/O voltage drop		
L88MS04T	Positive voltage	0.5							●															18	1.0	TP5H	4V low-saturation voltage regulator with strobe pin, 4V output voltage, 0.5A output current, strobe pin, 0.4V (typ) minimum I/O voltage drop		
L88MS05T	Positive voltage	0.5								●														18	1.0	TP5H	5V low-saturation voltage regulator with strobe pin, 5V output voltage, 0.5A output current, strobe pin, 0.4V (typ) minimum I/O voltage drop		
L88MS06T	Positive voltage	0.5									●													18	1.0	TP5H	6V low-saturation voltage regulator with strobe pin, 6V output voltage, 0.5A output current, strobe pin, 0.4V (typ) minimum I/O voltage drop		
L88MS08T	Positive voltage	0.5										●												18	1.0	TP5H	8V low-saturation voltage regulator with strobe pin, 8V output voltage, 0.5A output current, strobe pin, 0.4V (typ) minimum I/O voltage drop		
L88MS09T	Positive voltage	0.5											●											18	1.0	TP5H	9V low-saturation voltage regulator with strobe pin, 9V output voltage, 0.5A output current, strobe pin, 0.4V (typ) minimum I/O voltage drop		
L88MS12T	Positive voltage	0.5												●										18	1.0	TP5H	12V low-saturation voltage regulator with strobe pin, 12V output voltage, 0.5A output current, strobe pin, 0.4V (typ) minimum I/O voltage drop		
L88MS33T	Positive voltage	0.5					●																	18	1.0	TP5H	Low-saturation voltage regulator with on/off function, 3.3V output voltage, 0.5A output current, strobe pin, 0.4V (typ) minimum I/O voltage drop		
L88MS34T	Positive voltage	0.5						●																18	1.0	TP5H	3.4V low-saturation voltage regulator with strobe pin, 3.4V output voltage, 0.5A output current, strobe pin, 0.4V (typ) minimum I/O voltage drop		
L88R05C	Positive voltage	1.0								●														18	2.75	220-5H	4.5V low-saturation voltage regulator with reset pin, 5V output voltage, 1A output current, reset pin, 0.5V (typ) minimum I/O voltage drop		
L88R05D	Positive voltage	1.0									●													18	2.75	220-5H	4.2V low-saturation voltage regulator with reset pin, 5V output voltage, 1A output current, reset pin, 0.5V (typ) minimum I/O voltage drop		
L88R05E	Positive voltage	1.0										●												18	2.75	220-5H	3.9V low-saturation voltage regulator with reset pin, 5V output voltage, 1A output current, reset pin, 0.5V (typ) minimum I/O voltage drop		

Series Power Supply ICs

Type No.	Type	Output Current (A)	Output voltage (V)																						Absolute maximum ratings		Package	Features	P
			1.8	2	2.5	3	3.3	3.4	3.5	4	5	6	7	8	9	10	12	15	18	20	24	Input voltage (V)	Total power dissipation (W)						
L78LR05	Positive voltage	0.15																						25	1.0	TP5H	5V voltage regulator with reset pin, 5V output voltage, 150mA output current, reset pin		
L78M05T	Positive voltage	0.5																						35	1.0	TP3H	5V 0.5A 3-pin voltage regulators, 5V output voltage, 500mA output current, 1.0W power dissipation		
L78M06T	Positive voltage	0.5																						35	1.0	TP3H	6V 0.5A 3-pin voltage regulators, 6V output voltage, 500mA output current, 1.0W power dissipation		
L78M07T	Positive voltage	0.5																						35	1.0	TP3H	7V 0.5A 3-pin voltage regulators, 7V output voltage, 500mA output current, 1.0W power dissipation		
L78M08T	Positive voltage	0.5																						35	1.0	TP3H	8V 0.5A 3-pin voltage regulators, 8V output voltage, 500mA output current, 1.0W power dissipation		
L78M09T	Positive voltage	0.5																						35	1.0	TP3H	9V 0.5A 3-pin voltage regulators, 9V output voltage, 500mA output current, 1.0W power dissipation		
L78M10T	Positive voltage	0.5																						35	1.0	TP3H	10V 0.5A 3-pin voltage regulators, 10V output voltage, 500mA output current, 1.0W power dissipation		
L78M12T	Positive voltage	0.5																						35	1.0	TP3H	12V 0.5A 3-pin voltage regulators, 12V output voltage, 500mA output current, 1.0W power dissipation		
L78M15T	Positive voltage	0.5																						35	1.0	TP3H	15V 0.5A 3-pin voltage regulators, 15V output voltage, 500mA output current, 1.0W power dissipation		
L78M18T	Positive voltage	0.5																						35	1.0	TP3H	18V 0.5A 3-pin voltage regulators, 18V output voltage, 500mA output current, 1.0W power dissipation		
L78M20T	Positive voltage	0.5																						35	1.0	TP3H	20V 0.5A 3-pin voltage regulators, 20V output voltage, 500mA output current, 1.0W power dissipation		
L78M24T	Positive voltage	0.5																						35	1.0	TP3H	24V 0.5A 3-pin voltage regulators, 24V output voltage, 500mA output current, 1.0W power dissipation		
L78MG	Positive voltage	0.5																						35	1.2	SIP4H	Variable type 4-pin 500mA constant voltage power supply, 35V/500mA, Pd: 1.2W		
L780S05	Positive voltage	1.0																						35	1.75	220-5H	1A general-purpose voltage regulator, 5V output voltage, 1A output current, strobe pin, thermal protection and overcurrent limiter circuits		
L780S08	Positive voltage	1.0																						35	1.75	220-5H	1A general-purpose voltage regulator, 8V output voltage, 1A output current, strobe pin, thermal protection and overcurrent limiter circuits		
L780S09	Positive voltage	1.0																						35	1.75	220-5H	1A general-purpose voltage regulator, 9V output voltage, 1A output current, strobe pin, thermal protection and overcurrent limiter circuits		
L780S10	Positive voltage	1.0																						35	1.75	220-5H	1A general-purpose voltage regulator, 10V output voltage, 1A output current, strobe pin, thermal protection and overcurrent limiter circuits		

Continued on next page.

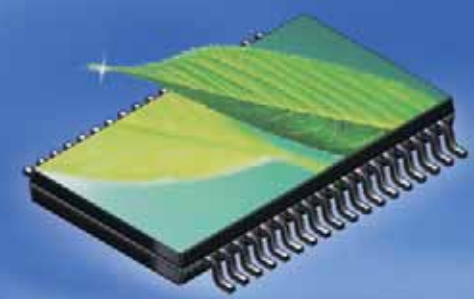

Series Power Supply ICs Continued from preceding page.

Type No.	Type	Output Current (A)	Output voltage (V)																						Absolute maximum ratings		Package	Features	P	
			1.8	2	2.5	3	3.3	3.4	3.5	4	5	6	7	8	9	10	12	15	18	20	24	Input voltage (V)	Total power dissipation (W)							
L780S12	Positive voltage	1.0																								35	1.75	220-5H	1A general-purpose voltage regulator, 12V output voltage, 1A output current, strobe pin, thermal protection and overcurrent limiter circuits	
L780S15	Positive voltage	1.0																								35	1.75	220-5H	1A general-purpose voltage regulator, 15V output voltage, 1A output current, strobe pin, thermal protection and overcurrent limiter circuits	
L780S18	Positive voltage	1.0																								35	1.75	220-5H	1A general-purpose voltage regulator, 18V output voltage, 1A output current, strobe pin, thermal protection and overcurrent limiter circuits	
L78MR05	Positive voltage	0.5																								35	1.75	220-5H	5V voltage regulator with reset pin, 5V output voltage, 0.5A output current	
L78MR06	Positive voltage	0.5																								35	1.75	220-5H	6V voltage regulator with reset pin, 6V output voltage, 0.5A output current	
L78MR08	Positive voltage	0.5																								35	1.75	220-5H	8V voltage regulator with reset pin, 8V output voltage, 0.5A output current	
L78MR12	Positive voltage	0.5																								35	1.75	220-5H	12V voltage regulator with reset pin, 12V output voltage, 0.5A output current	
L78MS05J	Positive voltage	0.5																								35	1.75	220-5H	5V voltage regulator with strobe pin, 5V output voltage, 0.5A output current, strobe pin (Features a low quiescent current of 35µA)	
L78MS05JSMP	Positive voltage	0.5																								35	2.0	SMP5	5V voltage regulator with strobe pin, 5V output voltage, 0.5A output current, strobe pin (Features a low quiescent current of 35µA)	
L79M05T	Negative voltage	0.5																								-35	1.0	TP3H	-5V 3 pin voltage regulator (minus output), -5V/0.5A, Pd: 1.0W	
L79M06T	Negative voltage	0.5																								-35	1.0	TP3H	-6V 3 pin voltage regulator (minus output), -6V/0.5A, Pd: 1.0W	
L79M08T	Negative voltage	0.5																								-35	1.0	TP3H	-8V 3 pin voltage regulator (minus output), -8V/0.5A, Pd: 1.0W	
L79M09T	Negative voltage	0.5																								-35	1.0	TP3H	-9V 3 pin voltage regulator (minus output), -9V/0.5A, Pd: 1.0W	
L79M10T	Negative voltage	0.5																								-35	1.0	TP3H	-10V 3 pin voltage regulator (minus output), -10V/0.5A, Pd: 1.0W	
L79M12T	Negative voltage	0.5																								-35	1.0	TP3H	-12V 3 pin voltage regulator (minus output), -12V/0.5A, Pd: 1.0W	

Power Supply Switching ICs

Type No.	Package	Input voltage (V)			Applications	P
		V _{CC1}	V _{CC2}	V _{CC3}		
LV5621LP	VCT16(2.6x2.6)	2.7 to 4.8	3	3.5 to 5.2	For DSCs and game machines	20
LV5622LP	VCT16(2.6x2.6)	2.7 to 4.8	3	3.5 to 5.2	For DSCs and game machines	
LV5625V	SSOP16(225mil)	1.45 to 3.4	3	3.5 to 5.2	For DSCs and game machines	

Power ICs with a Watchdog Timer Function

Type No.	Absolute maximum ratings Input voltage (V)	Total power dissipation (W)	Package	Function reset logic output	Reset hold	5V regulator control	Regulator output ON/OFF	Edge detection	Watchdog time typ (Ct=2µF)	P
LA5690D	41	0.5	DIP8(300mil)	Noninverted/Inverted		●		●	5ms	
LA5690S	41	0.5	SIP9	Noninverted/Inverted		●		●	5ms	
LA5691S	41	0.5	SIP9	Inverted		●	●	●	5ms	
LA5692D	41	0.5	DIP8(300mil)	Inverted	●	●		●	40ms	
LA5692M	41	0.37	MFP8(225mil)	Inverted	●	●		●	40ms	
LA5692S	41	0.5	SIP9	Inverted	●	●		●	40ms	
LA5693AM	41	0.37	MFP8(225mil)	Inverted	●	●			40ms	21
LA5693D	41	0.5	DIP8(300mil)	Inverted	●	●			40ms	21
LA5693M	41	0.5	MFP8(225mil)	Inverted	●	●			40ms	21

Dual-Protection ICs

Type No.	Absolute maximum ratings		Package	Functions/Features	P
	Input voltage (V)	Total power dissipation (W)			
LA5695M	18	0.4	MFP14(225mil)	Protection ICs for heating/cooling equipment and OA equipment, Built-in abnormal supply voltage detection circuit, driver output with built-in output delay circuit, can be controlled from 8 input pins.	

Dual-Protection ICs (for Rechargeable Lithium-ion Batteries)

●: New products and
※: Development

Type No.	Absolute maximum ratings		Package	Functions/Features	P
	Input voltage (V)	Total power dissipation (W)			
● LV5113T	-0.3 to +12	0.17	MSOP8(150mil)	2-cell Lithium-ion rechargeable battery protection IC	
● LV5122T	-0.3 to +12	0.17	MSOP8(150mil)	2-cell Lithium-ion rechargeable battery protection IC	
※ LV51130T	-0.3 to +12	0.17	MSOP8(150mil)	2-cell Lithium-ion rechargeable battery protection IC	
● LV51131T	-0.3 to +12	0.17	MSOP8(150mil)	2-cell Lithium-ion rechargeable battery protection IC	
※ LV51132T	-0.3 to +12	0.17	MSOP8(150mil)	2-cell Lithium-ion rechargeable battery protection IC	
※ LV51133T	-0.3 to +12	0.17	MSOP8(150mil)	2-cell Lithium-ion rechargeable battery protection IC	
● LV51134T	-0.3 to +12	0.17	MSOP8(150mil)	2-cell Lithium-ion rechargeable battery protection IC	
※ LV51135T	-0.3 to +12	0.17	MSOP8(150mil)	2-cell Lithium-ion rechargeable battery protection IC	
※ LV51136T	-0.3 to +12	0.17	MSOP8(150mil)	2-cell Lithium-ion rechargeable battery protection IC	
● LV51137T	-0.3 to +12	0.17	MSOP8(150mil)	2-cell Lithium-ion rechargeable battery protection IC	
● LV51138T	-0.3 to +12	0.17	MSOP8(150mil)	2-cell Lithium-ion rechargeable battery protection IC	
※ LV5125T	-0.3 to +12	0.17	MSOP8(150mil)	2-cell Lithium-ion rechargeable battery protection IC	
※ LV51110T	-0.3 to +7	0.35	SOT-23-6	1-cell Lithium-ion rechargeable battery protection IC	
※ LV51110LF	-0.3 to +7	0.3	SON5(1.6x2.0)	1-cell Lithium-ion rechargeable battery protection IC	
※ LV51111T	-0.3 to +7	0.35	SOT-23-6	1-cell Lithium-ion rechargeable battery protection IC	
※ LV51111LF	-0.3 to +7	0.3	SON5(1.6x2.0)	1-cell Lithium-ion rechargeable battery protection IC	
※ LV51112T	-0.3 to +7	0.35	SOT-23-6	1-cell Lithium-ion rechargeable battery protection IC	
※ LV51112LF	-0.3 to +7	0.3	SON5(1.6x2.0)	1-cell Lithium-ion rechargeable battery protection IC	
※ LV51113T	-0.3 to +7	0.35	SOT-23-6	1-cell Lithium-ion rechargeable battery protection IC	
※ LV51113LF	-0.3 to +7	0.3	SON5(1.6x2.0)	1-cell Lithium-ion rechargeable battery protection IC	
※ LV51114T	-0.3 to +7	0.35	SON5(1.6x2.0)	1-cell Lithium-ion rechargeable battery protection IC	

Continued on next page.

DC-DC Converter (Control) ICs [Step down] LA5734MP/71/71MP/72/72MP/ 74/74MP/77/77MP/79/79MP



Dual-Protection ICs (for Rechargeable Lithium-ion Batteries)

Continued from preceding page.

●: New products and
※: Development

Type No.	Absolute maximum ratings		Package	Functions/Features	P
	Input voltage (V)	Total power dissipation (W)			
※ LV51114LF	-0.3 to +7	0.3	SON5(1.6×2.0)	1-cell Lithium-ion rechargeable battery protection IC	
※ LV51115T	-0.3 to +7	0.35	SOT-23-6	1-cell Lithium-ion rechargeable battery protection IC	
※ LV51115LF	-0.3 to +7	0.3	SON5(1.6×2.0)	1-cell Lithium-ion rechargeable battery protection IC	
※ LV51116T	-0.3 to +7	0.35	SOT-23-6	1-cell Lithium-ion rechargeable battery protection IC	
※ LV51116LF	-0.3 to +7	0.3	SON5(1.6×2.0)	1-cell Lithium-ion rechargeable battery protection IC	
※ LV51117T	-0.3 to +7	0.35	SOT-23-6	1-cell Lithium-ion rechargeable battery protection IC	
※ LV51117LF	-0.3 to +7	0.3	SON5(1.6×2.0)	1-cell Lithium-ion rechargeable battery protection IC	
※ LV51118T	-0.3 to +7	0.35	SOT-23-6	1-cell Lithium-ion rechargeable battery protection IC	
※ LV51118LF	-0.3 to +7	0.3	SON5(1.6×2.0)	1-cell Lithium-ion rechargeable battery protection IC	
※ LV51119T	-0.3 to +7	0.35	SOT-23-6	1-cell Lithium-ion rechargeable battery protection IC	
※ LV51119LF	-0.3 to +7	0.3	SON5(1.6×2.0)	1-cell Lithium-ion rechargeable battery protection IC	
● LV51140T	-0.3 to +7	0.35	SOT-23-6	1-cell Lithium-ion rechargeable battery protection IC	
※ LV51140LF	-0.3 to +7	0.3	SON5(1.6×2.0)	1-cell Lithium-ion rechargeable battery protection IC	
● LV51141T	-0.3 to +7	0.35	SOT-23-6	1-cell Lithium-ion rechargeable battery protection IC	
※ LV51141LF	-0.3 to +7	0.3	SON5(1.6×2.0)	1-cell Lithium-ion rechargeable battery protection IC	
※ LV51142T	-0.3 to +7	0.35	SOT-23-6	1-cell Lithium-ion rechargeable battery protection IC	
※ LV51142LF	-0.3 to +7	0.3	SON5(1.6×2.0)	1-cell Lithium-ion rechargeable battery protection IC	

Rechargeable Battery Charge Control ICs

※: Development

Type No.	Battery type	Absolute maximum ratings Input voltage (V)	Total power dissipation (W)	Package	Functions/Features	P
LA5636M	Lithium-ion, nickel-metal hydride	14.5	0.36	MFP10S(225mil)	Car battery DC/DC converter control IC, output voltage proportional to PWM input signal, for charging lithium-ion batteries	22
※ LA5645M	Charger	14.5	0.3	MFP8(225mil)	Constant-voltage, constant-current control IC, high precision reference voltage (1.5V±1%), input offset voltage (2mV max.)	

Dedicated Reset Function ICs

Type No.	Absolute maximum ratings Input voltage (V)	Total power dissipation (W)	Package	Functions/Features	P
LA5623M	-0.3 to +12	0.3	MFP8(225mil)	2-system reset IC with built-in 1.25V, and 4.2V reference voltages, delay time 25ms, 50ms, 100ms, or 200ms switchable	23

LED Driver ICs

●: New products

Type No.	Input voltage	Channels	Package	Circuit functions and applications	P
LV5213LP	3.0 to 4.5	3ch	VCT16(2.6×2.6)	3-channel LED driver for cell phones	
● LV5215LF	3.0 to 4.5	4ch	VQFN12(2.0×2.0)	4-channel LED driver for cell phones	24
● LV5217GP	3.0 to 4.5	3ch	VCT16(2.6×2.6)	3-channel LED driver for cell phones	25

Applications

Separately-excited step-down switching regulator

Functions/Features

- Low-ESR capacitor with increased reliability applicable as the output smoothing capacitor (LA5774/74MP)
- High efficiency
- 4 external parts
- Built-in reference oscillator (160kHz)
- Built-in current limiter
- Built-in thermal shutdown circuit
- Built-in soft start circuit (LA5771/71MP/72/72MP/74/74MP)
- ON/OFF function (LA5734/77/77MP/79/79MP)

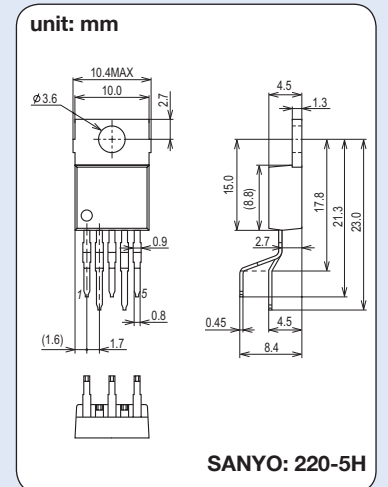
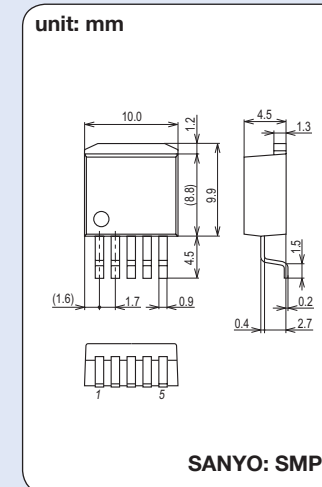

Type	Input voltage	Output voltage	Channels	Power stages	Package
Step down	<ul style="list-style-type: none"> ● 4.5V to 28V (LA5774/74MP/79/79MP) ● 4.5V to 32V (LA5734MP) ● 5.5V to 28V (LA5771MP) ● 5.5V to 32V (LA5771) ● 7V to 28V (LA5772MP) ● 7V to 32V (LA5772) ● 8V to 28V (LA5777/77MP) 	<ul style="list-style-type: none"> ● Programmable externally/3A (LA5734MP/74/74MP/79/79MP) ● 3.3V/3A (LA5771MP/71) ● 5V/3A (LA5772MP/72/77/77MP) 	1ch	Built in	<ul style="list-style-type: none"> ● 220-5H (LA5771/72/74/77/79) ● SMP5 (LA5734MP/71MP/72MP/74MP/77MP/79MP)

Block Diagram

Example: LA5771 Block Diagram

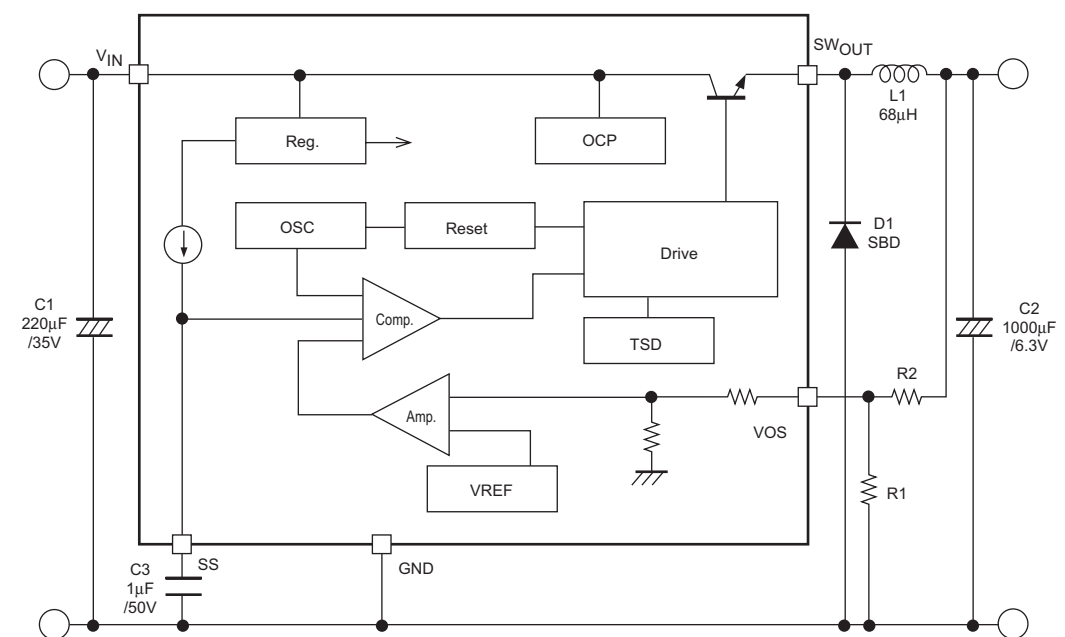

* For other block diagrams, refer to the datasheet.

DC-DC Converter (Control) ICs [Step down]

LV5803M

Applications

DC-DC converter

Functions/Features

- 2A 1-channel step-down switching regulator
- Wide input dynamic range (4.5 to 18V)
- High efficiency : 90% $I_{OUT}=1A, V_{IN}=12V, V_O=5V$
- Compact package : MFP8
- Standby mode
- Overcurrent protection
- Thermal shutdown
- Fixed frequency : 330kHz
- Reference voltage : 0.8V
- Soft start function

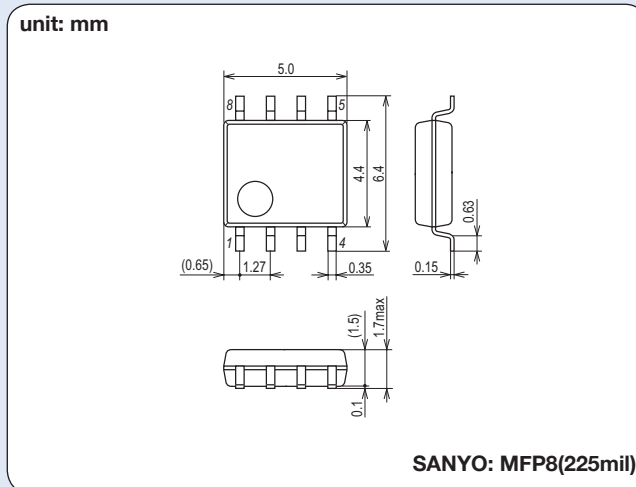

Type	Input voltage	Output voltage	Channels	Power stages	Package
Step down	4.5V to 18V	Programmable externally	1ch	Built in	MFP8(225mil)

DC-DC Converter (Control) ICs [Separately-excited step-down]

TN8D41A/51A, TN5D41A/51A/61A

Applications

Separately-excited step-down switching regulator

Functions/Features

- Large current : I_O max 8A (TN8D41A/51A)
: I_O max 5A (TN5D41A/51A/61A)
- High efficiency : Vertical-type P-channel power MOSFET built-in
- High withstand voltage : V_{IN} max 57V
- Five external parts
- Built-in reference oscillator (150kHz)
- Built-in current limiter
- Built-in thermal shutdown circuit
- Built-in soft start circuit
- ON/OFF function (shared with soft start pin)

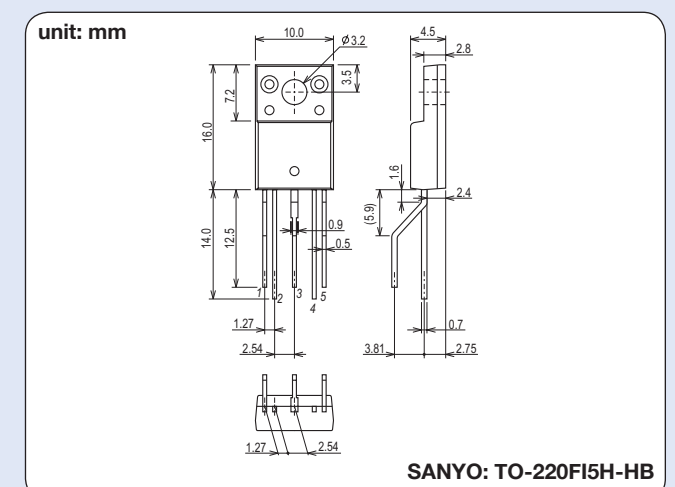

Type	Input voltage	Output voltage	Channels	Power stages	Package
Step down	10V to 40V (TN8D41A/TN5D41A) 20V to 48V (TN8D51A/TN5D51A) 30V to 48V (TN5D61A)	5V/5A (TN5D41A), 12V/5A (TN5D51A), 24V/5A (TN5D61A) 5V/8A (TN8D41A), 12V/8A (TN8D51A)	1ch	Built in (PMOS)	TO-220FI5H-HB

Block Diagram

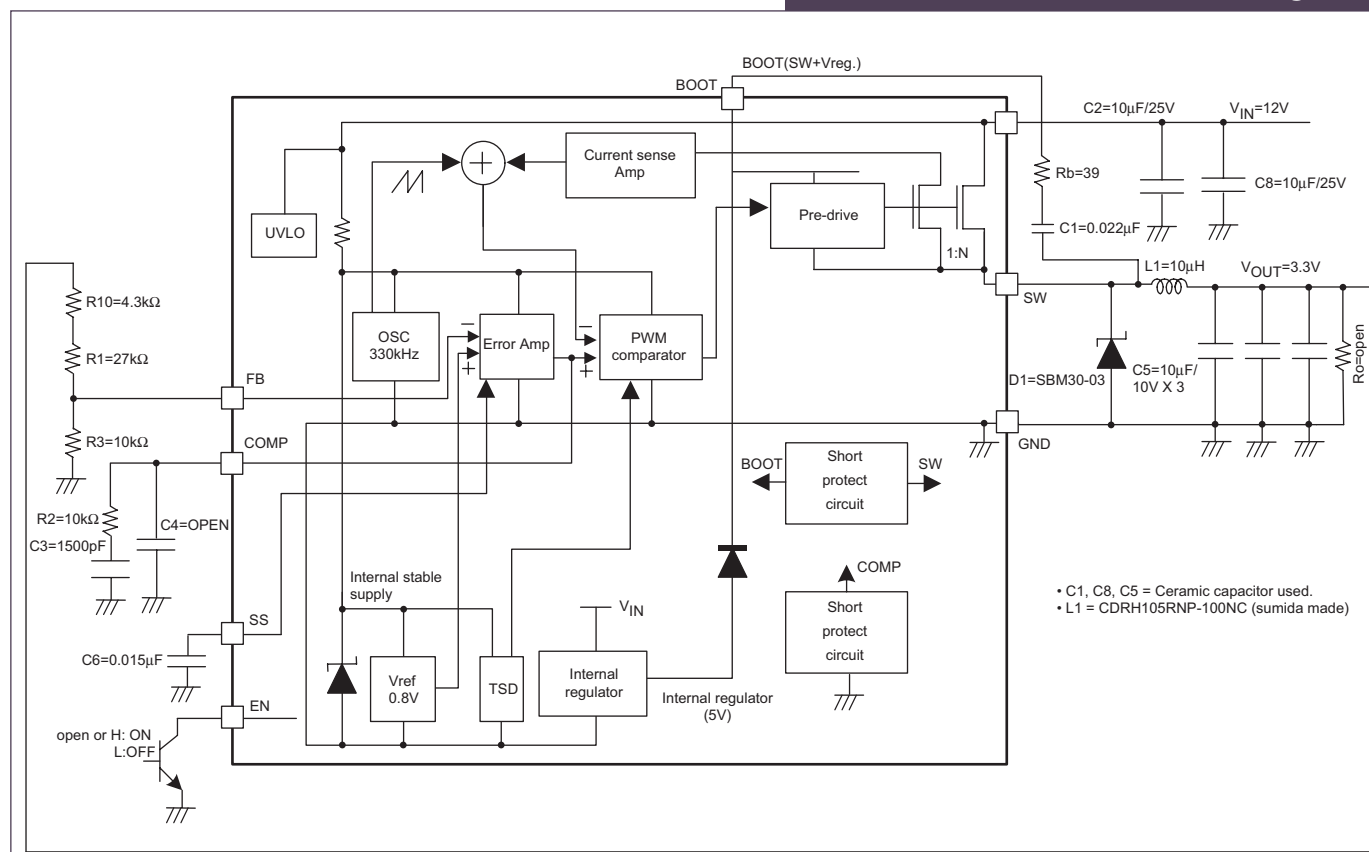

Block Diagram

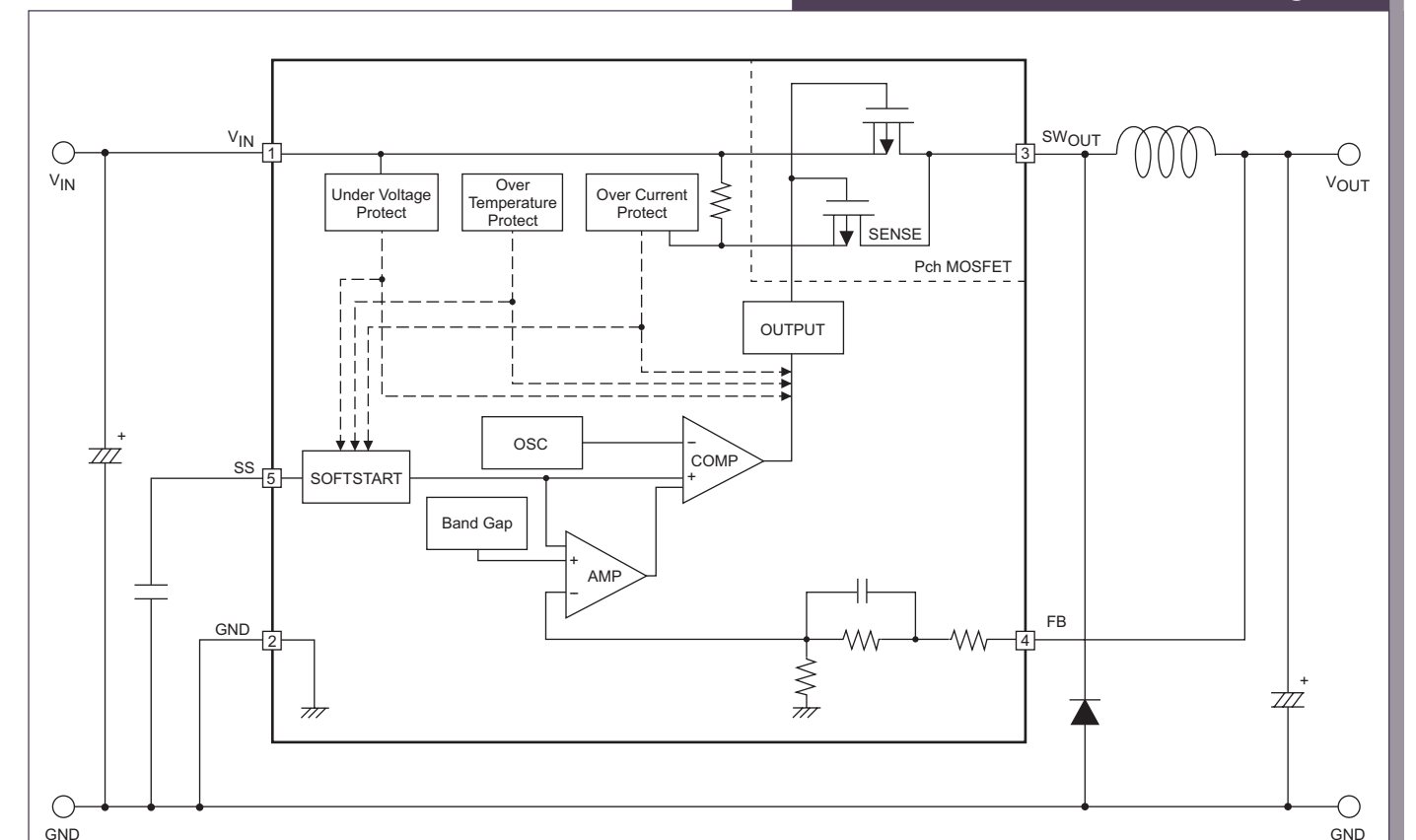

DC-DC Converter (Control) ICs [Synchronous rectification type]

LV5050V

AC-DC Converter (Control) ICs

LA5648

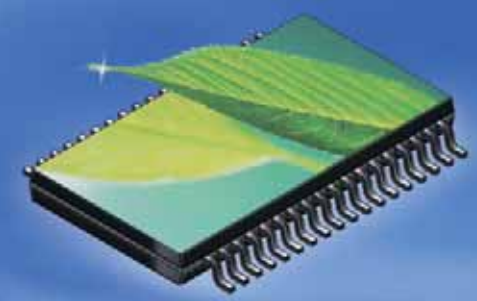

Applications

DC-DC converter

Functions/Features

- Step-down DC-DC converter controller with 1-channel
- Input UVLO circuit, overcurrent detection function, soft start/soft stop function, start-up delay circuit
- Output voltage monitor function (Under voltage protection with power good and timer latch)
- Synchronized operation is possible between different devices

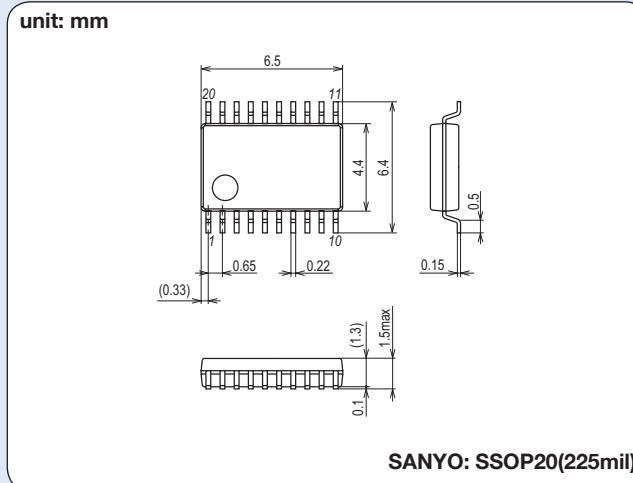

Type	Input Voltage	Output Voltage	Channels	Power Stages	Package
Step down	7.5V to 16V 4.5V to 6V	Programmable externally	1ch	External (NMOS)	SSOP20(225mil)

Applications

RCC power supply controller

Functions/Features

- RCC power supply controller
- Overcurrent detection function
- Soft start function
- Input UVLO circuit
- Output overcurrent protection timer function
- Base winding voltage detection function

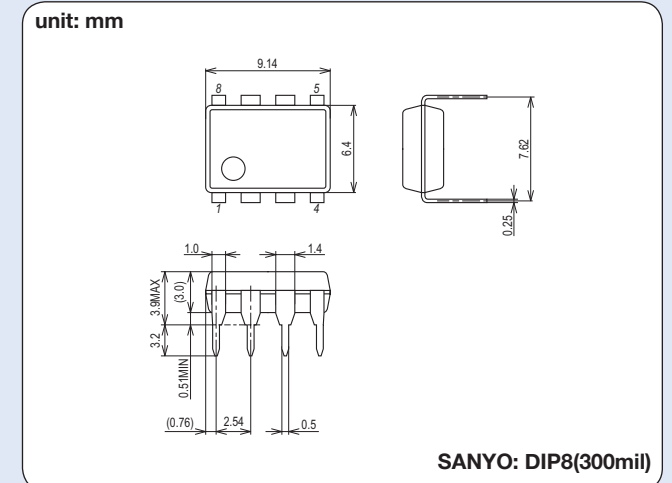

Functions	VCC	Features	Package
RCC/separately-excited fly-back AC-DC converter controller	30	UVLO, primary side PbyPOCP, secondary side timer type OCP	DIP8(300mil)

Block Diagram

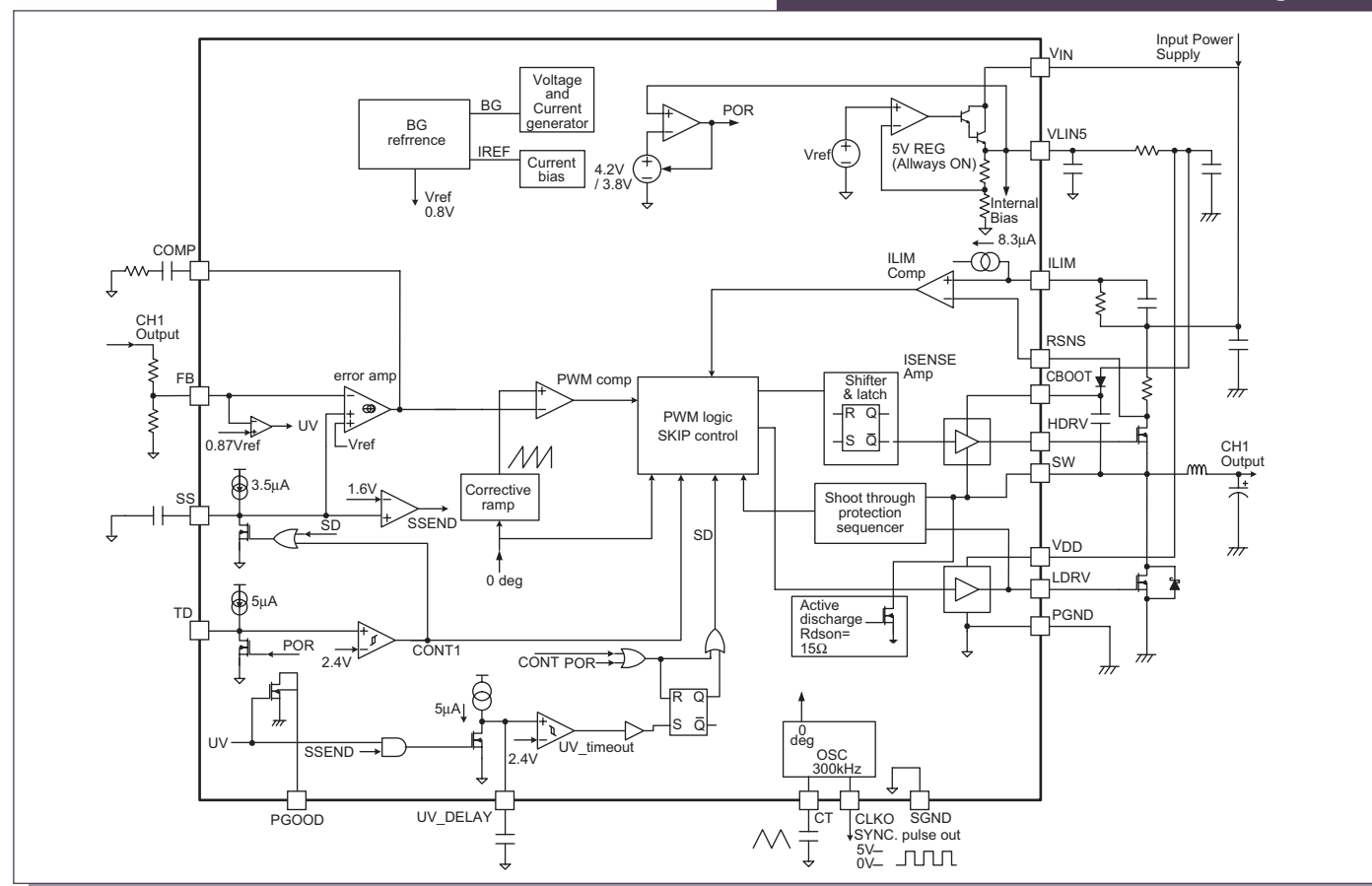

Block Diagram

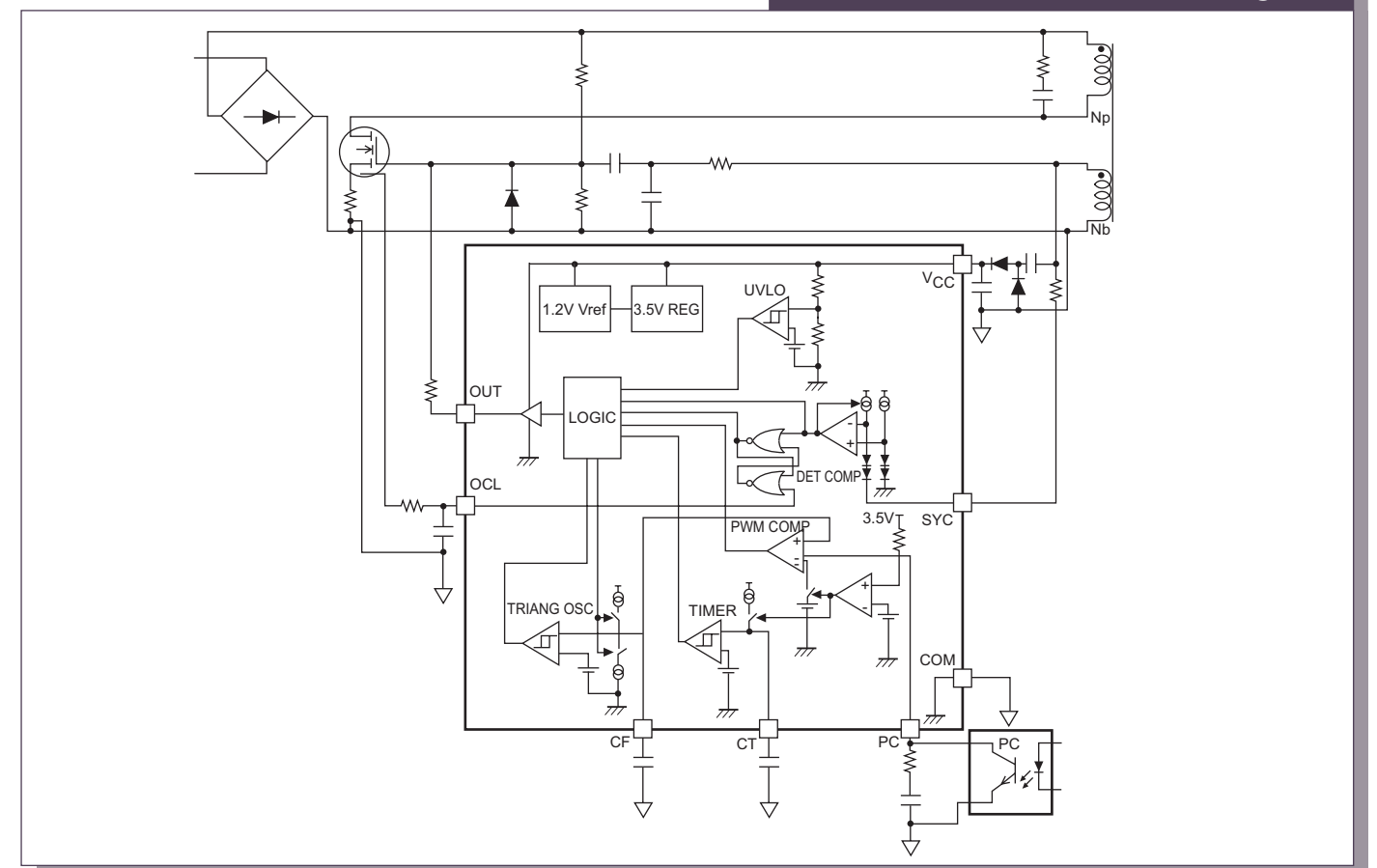

LV5603T

Applications

6-channel switching regulator control IC

Functions/Features

- Low voltage (3V minimum) operation
- Reference voltage precision: $\pm 1\%$
- Independent standby function for each of the 6 channels
- Is capable of driving MOS transistors
- Synchronous rectification: channels 1 and 2
- Supports inverting step-up operation

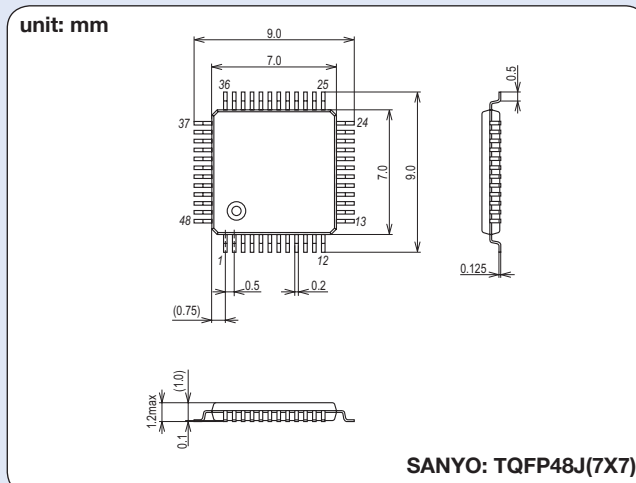

Type	Input voltage	Output voltage	Channels	Power stages	Package
Multiple power supply	3V to 15V	Programmable externally	6ch (Step up 2, down 4)	External	TQFP48J(7×7)

LV5655



Applications

3-channel switching regulator control IC

Functions/Features

- Low voltage (3V minimum) operation
- Reference voltage precision: $\pm 1\%$
- Built-in standby circuit
- Synchronous rectification: channels 1 and 2
- 3-channel independent soft start

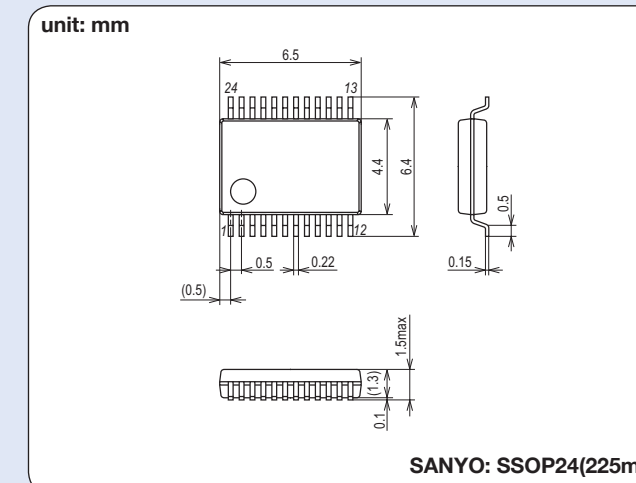

Type	Input voltage	Output voltage	Channels	Power stages	Package
Multiple power supply	3V to 15V	Programmable externally	3ch (Step up 1, down 2)	External	SSOP24(225mil)

Block Diagram

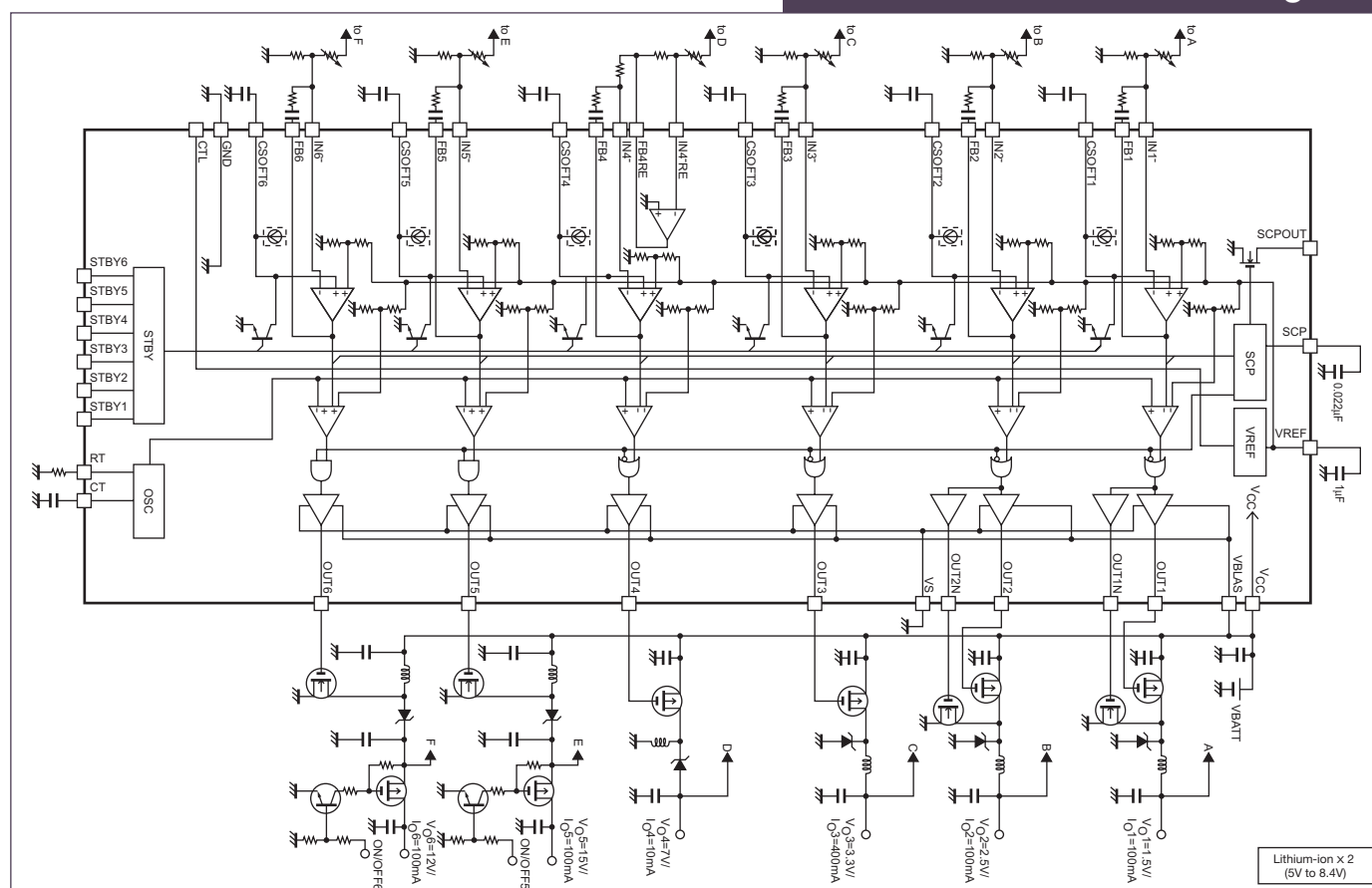

Block Diagram

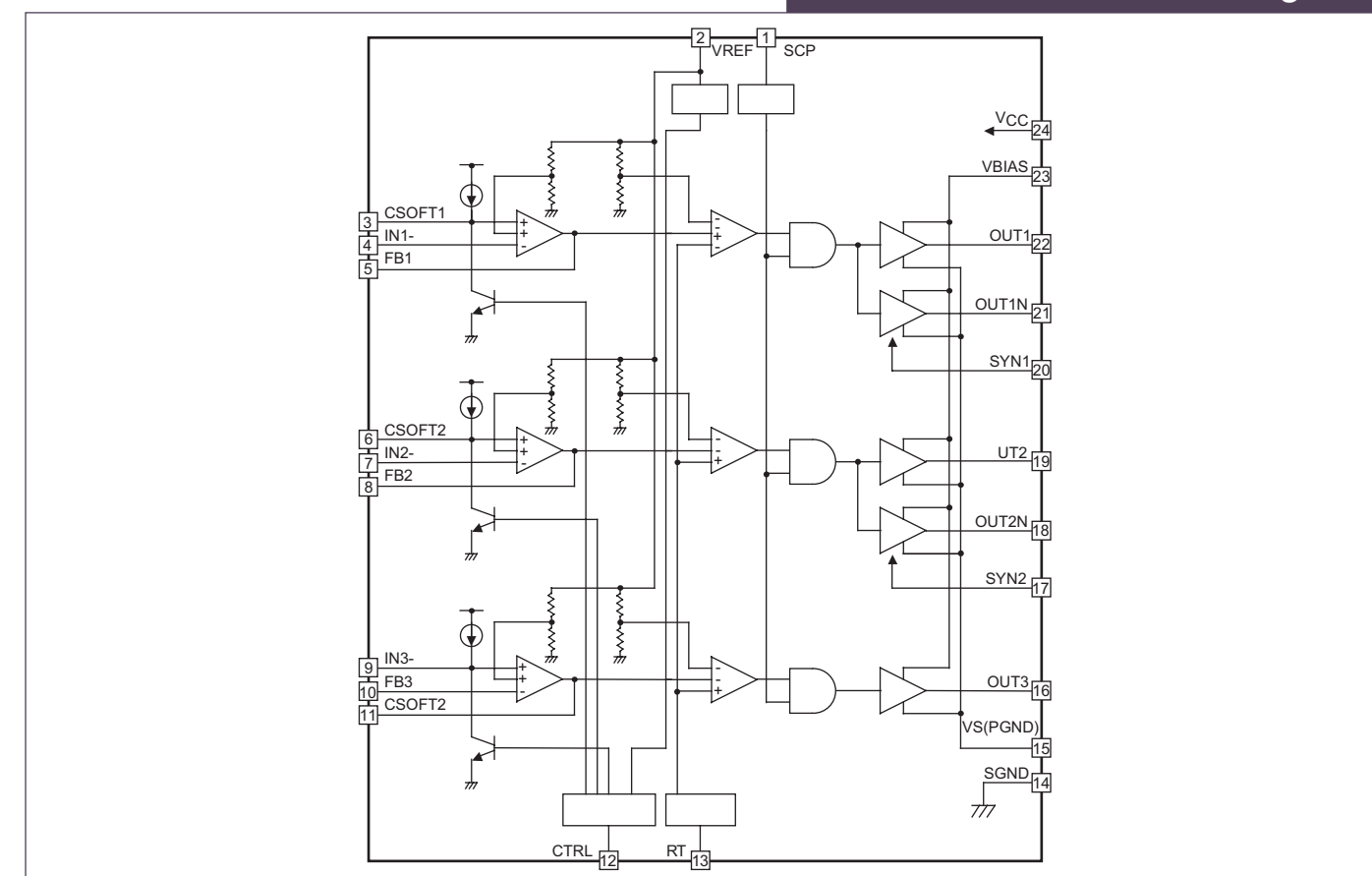

LV5604T

LV5621LP

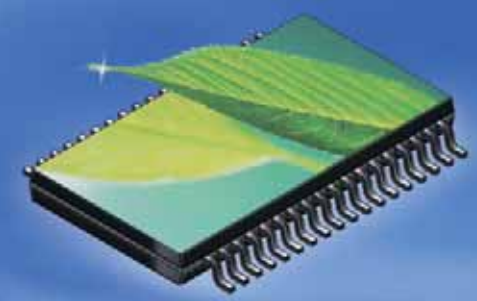

Applications

8-channel switching regulator control IC

Functions/Features

- Low voltage (3V minimum) operation
- Reference voltage precision: $\pm 1\%$
- Independent standby function for each of the 8 channels
- Is capable of driving MOS transistors
- Synchronous rectification: channels 1 and 2
- Supports inverting step-up operation

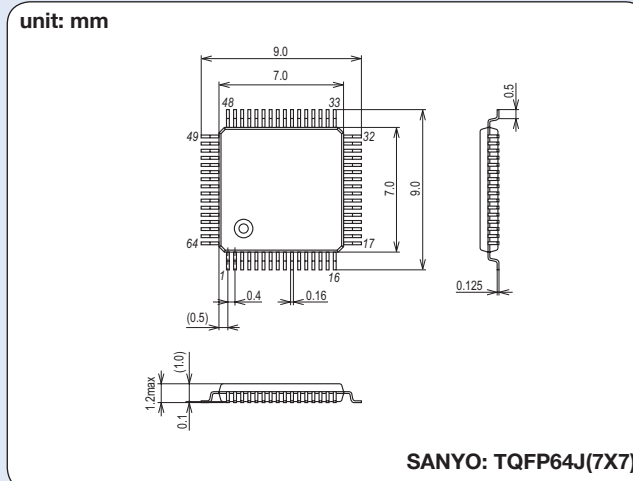

Type	Input voltage	Output voltage	Channels	Power stages	Package
Multiple power supply	3V to 15V	Programmable externally	8ch (Step up 3, down 5)	External	TQFP64J(7×7)

Applications

For digital still cameras
Switching IC between main and backup power supplies

Functions/Features

- Low power dissipation
- Switching among 3 power sources (main battery, button battery, external power supply)
- LDO×3 (2.6V, 3.0V, 3.2V)
- Three voltage detection circuits (2.6V, 2.8V, 2.2V)

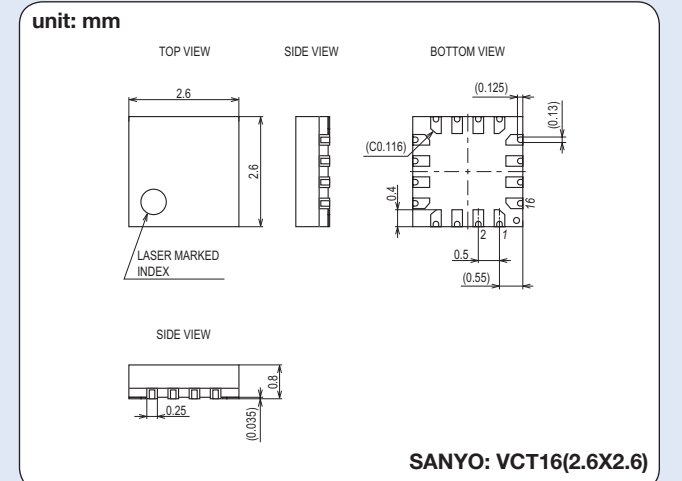

Input voltage	Package	Applications
V _{CC1} : 2.7V to 4.8V	VCT16(2.6×2.6)	For DSCs and game machines

Block Diagram

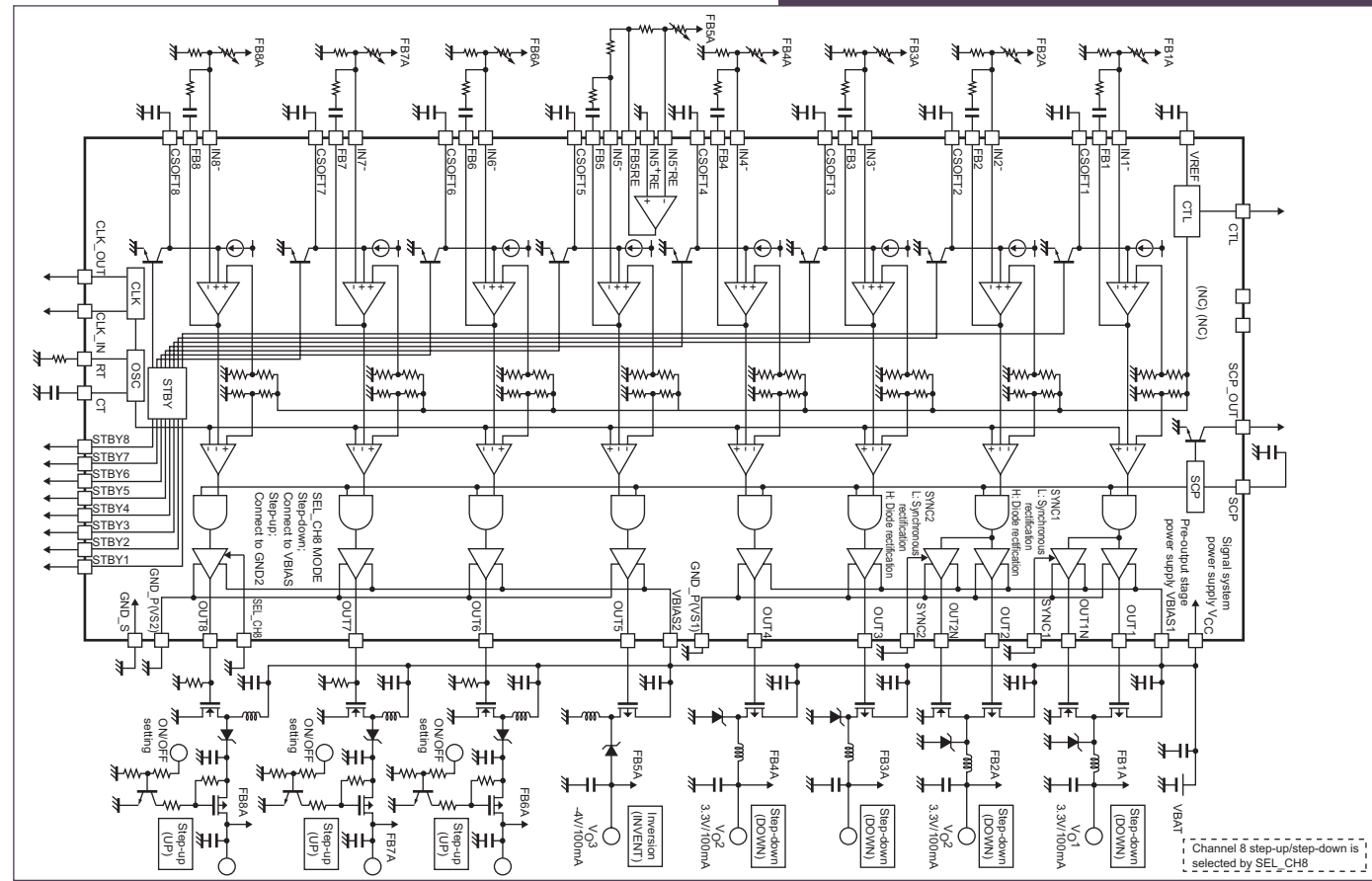

Block Diagram

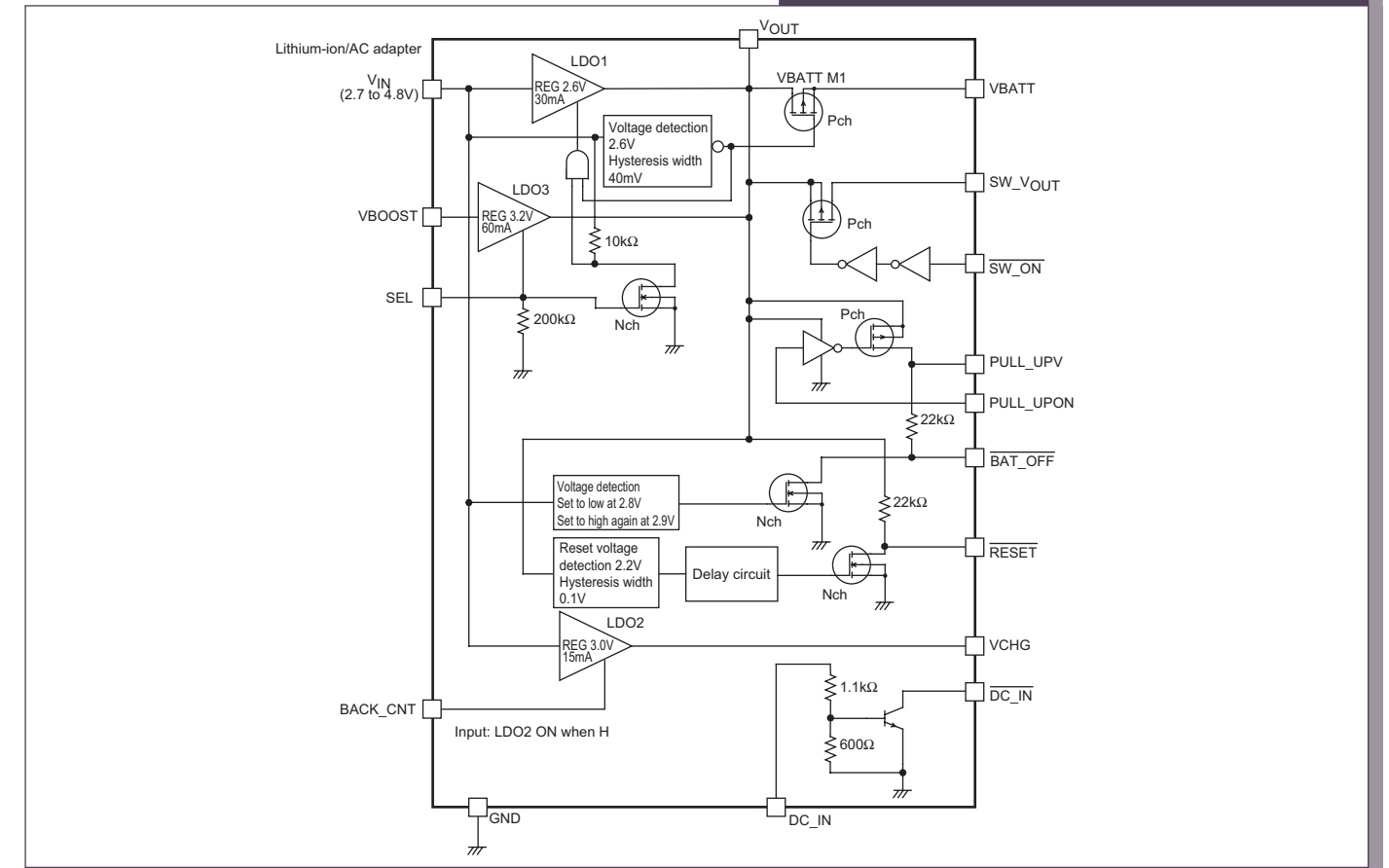

Power ICs with a Watchdog Timer Function

LA5693AM/93D/93M

Rechargeable Battery Charge Control ICs

LA5636M



Applications

Microcontroller systems for use in automobiles and other industrial equipment

Functions/Features

- An external PNP transistor can be used to provide a low-saturation voltage regulator
- Since the CK input has no edge detector, a high degree of flexibility is allowed in applications (LA5693AM)
- Variable detection voltage (LA5693AM)
- Watchdog time can be made longer (LA5693AM)
- 5V output voltage power supply controller (LA5693D/93M)
- Built-in watchdog timer (LA5693D/93M)
- Power supply reset signal generation function (LA5693D/93M)
- Reset hold output RES(2) (cleared with CK reinput) (LA5693D/93M)

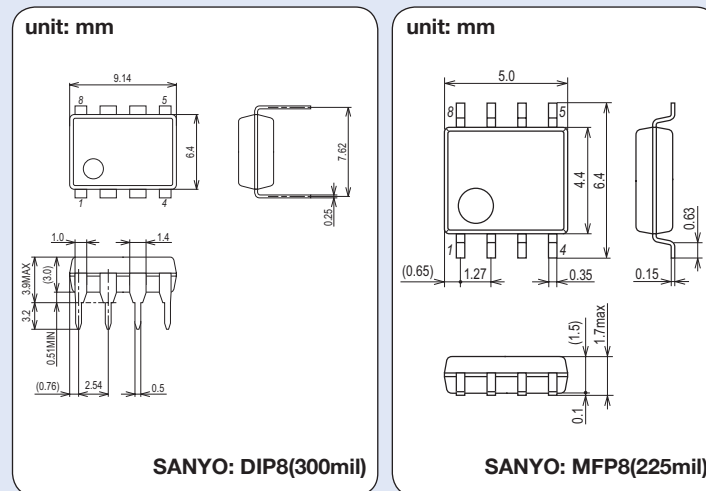

Absolute maximum ratings input voltage	Total power dissipation	Package	Function reset logic output	Watchdog time typ (Ct=2μF)
41V	0.37W (LA5693AM) 0.5W (LA5693D/93M)	MFP8(225mil) (LA5693AM/93M) DIP8(300mil) (LA5693D)	Inverted	40ms

Applications

DC-DC converter secondary side control IC

Functions/Features

- Built-in circuit that prevents system malfunction when the input voltage (car battery voltage) falls.
- Provides a constant voltage output that in proportion to the PWM input signal (permits output voltage control by microcontroller)
- High-precision reference current (current control amp) $92.5\mu\text{A} \pm 2.7\%$
- Output voltage can be set through an external resistor.
- Each loop of the voltage amp and current amp is independent.

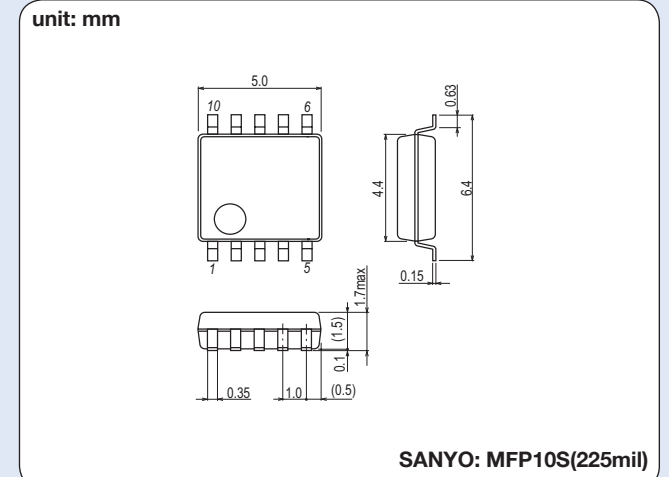

Battery type	Absolute maximum ratings Input voltage	Total power dissipation	Package	Functions/Features
Lithium-ion, nickel-metal hydride	14.5V	0.36W	MFP10S(225mil)	Car battery DC-DC converter control IC, output voltage proportional to PWM input signal for charging lithium-ion batteries, etc.

Block Diagram

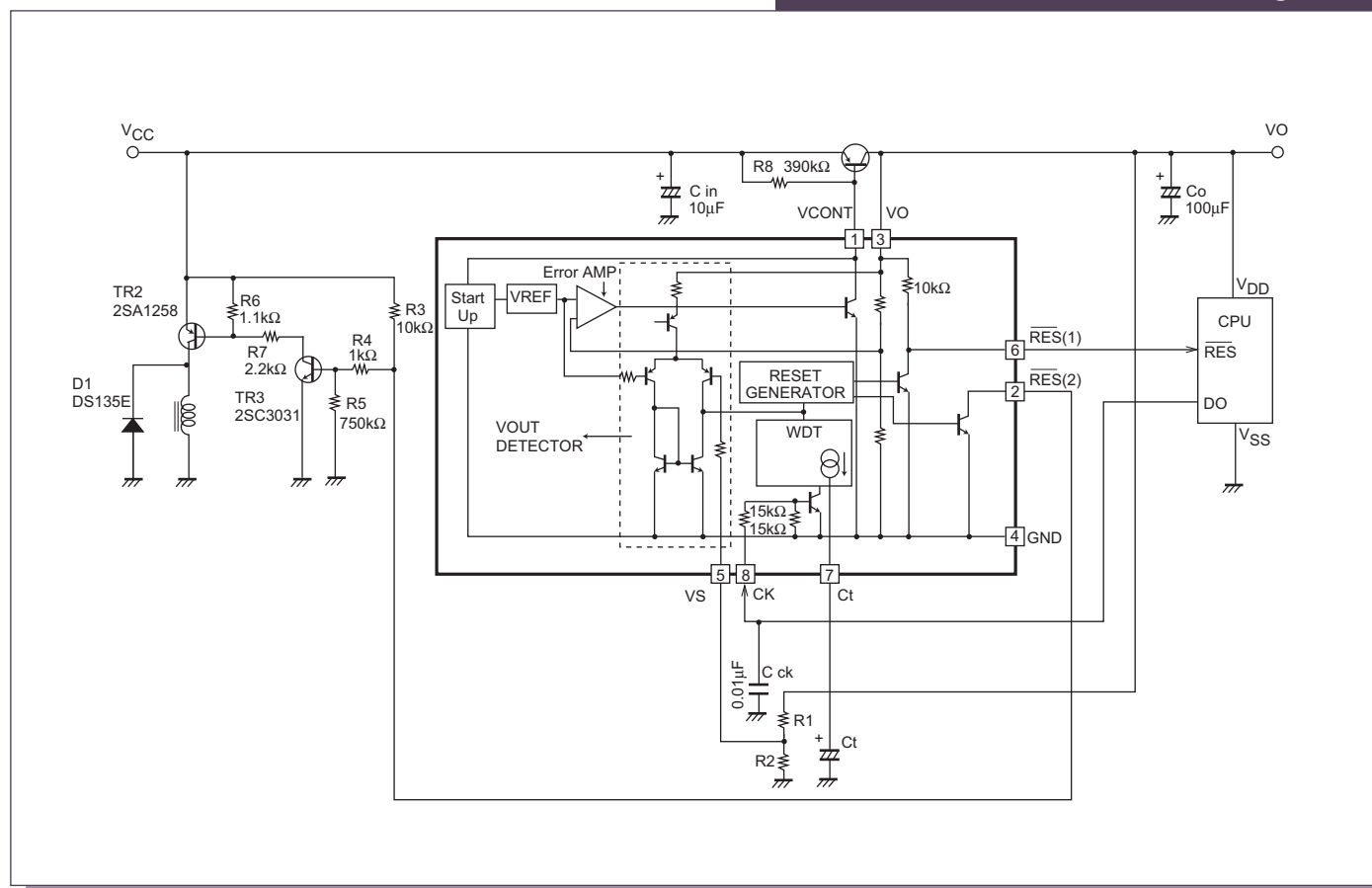

Block Diagram

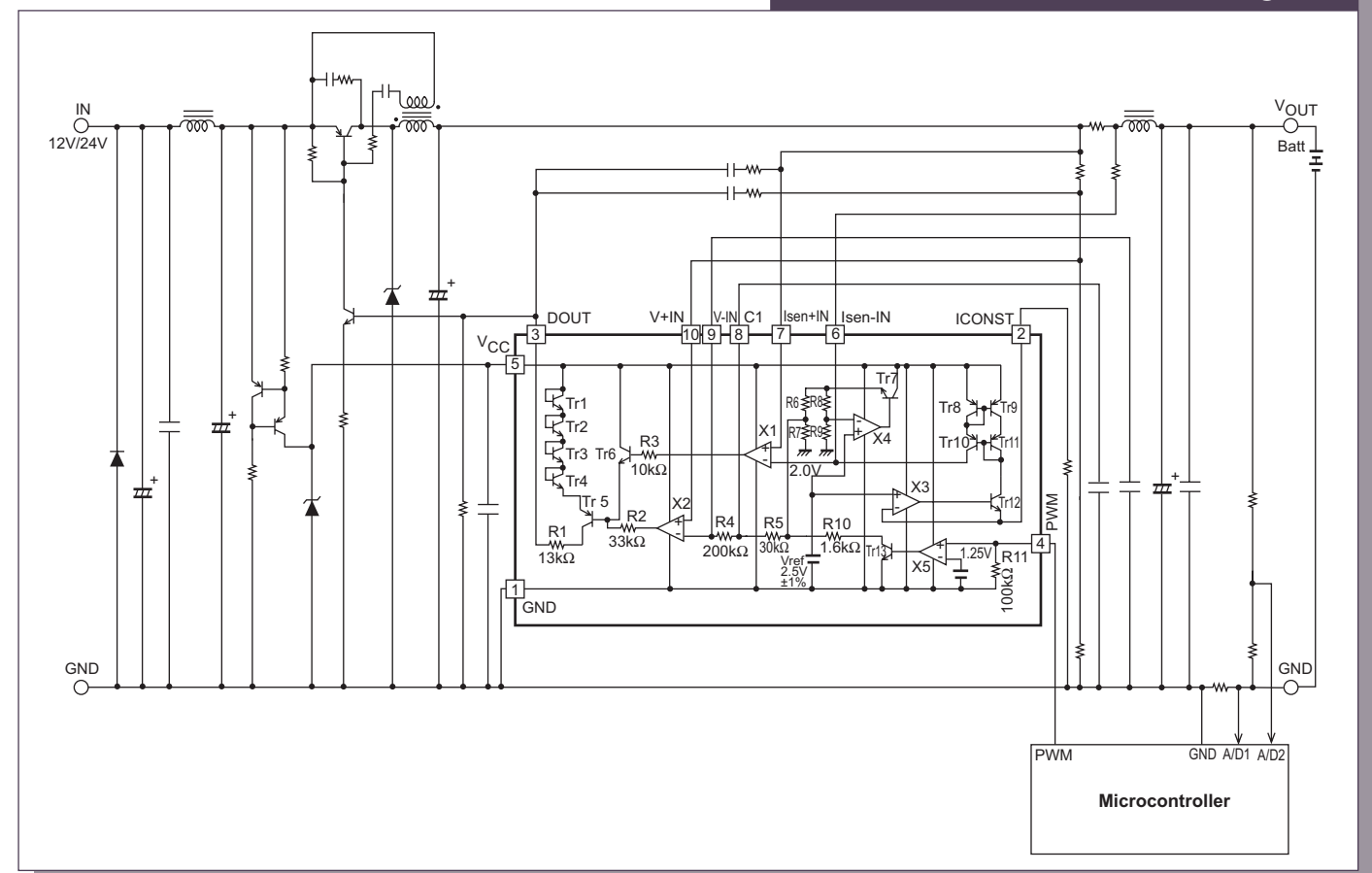

Dedicated Reset Function ICs

LA5623M

LED Driver ICs

LV5215LF

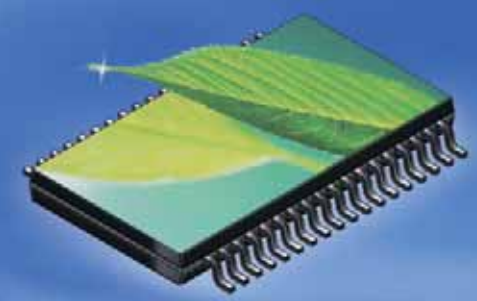

Applications

Combination system reset IC

Functions/Features

- Reset circuit (output 1) that detects the input voltage and provides a delay time of 200 μ s
- System reset circuit with switchable delay time of 25ms, 50ms, 100ms, and 200ms (output 2)
- Low minimum operating voltage
- Both reset 1 and reset 2 have hysteresis characteristics

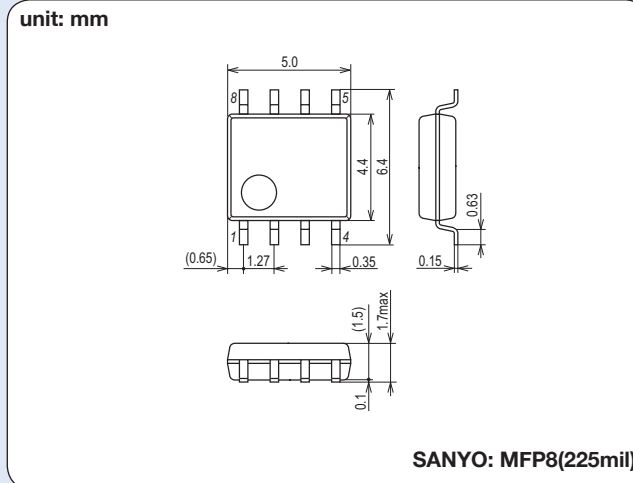

Absolute maximum ratings	Total power dissipation	Package	Functions/Features
Input voltage -0.3V to +12V	0.3W	MFP8(225mil)	2-system reset IC with built-in 1.25V, and 4.2V reference voltages, delay time 25ms, 50ms, 100ms, or 200ms switchable

Applications

LED driver for use in cell phones

Functions/Features

- Four main LED driver circuits
- Supports two LED current modes
- Compact package
- Thermal shutdown function

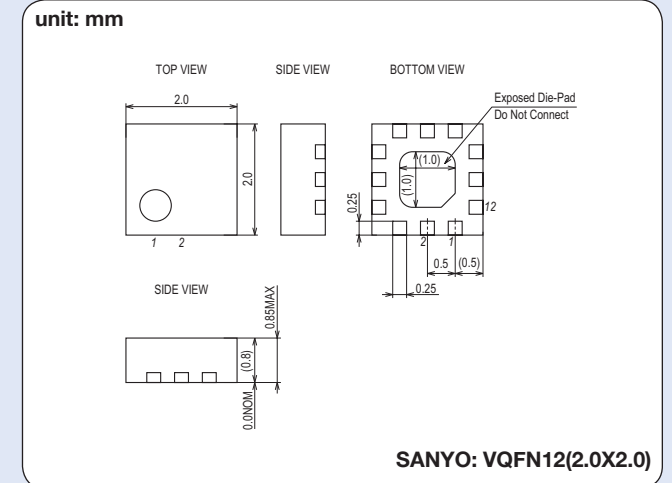

Input voltage	Channels	Package	Circuit Functions and Applications
3.0V to 4.5V	4ch	VQFN12(2.0x2.0)	LED driver for use in cell phones

Block Diagram

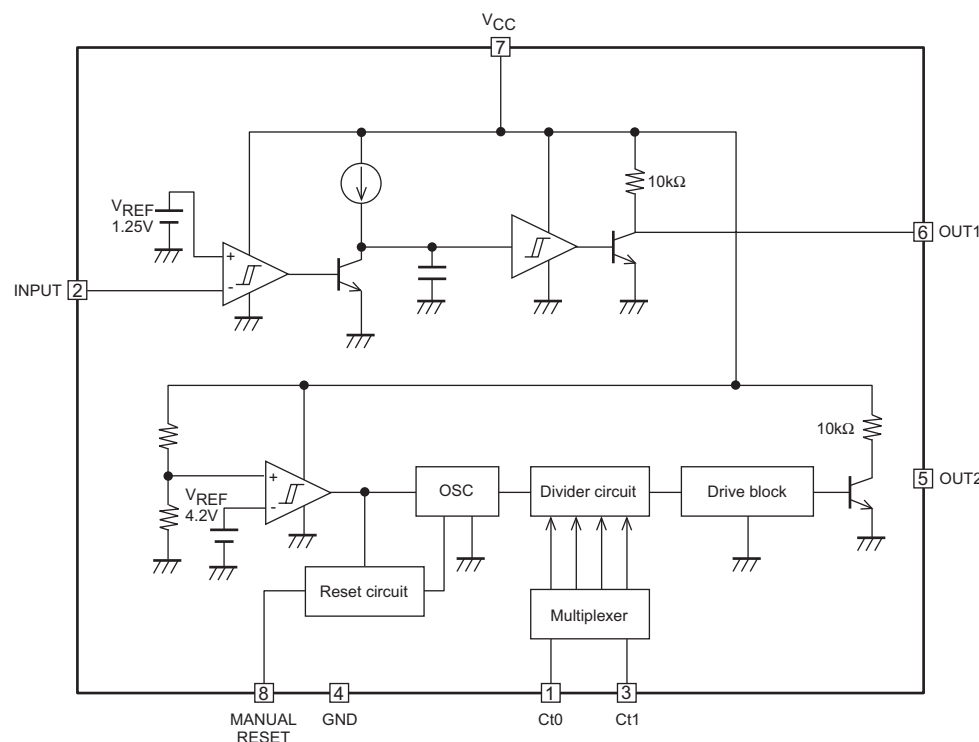

Block Diagram

