

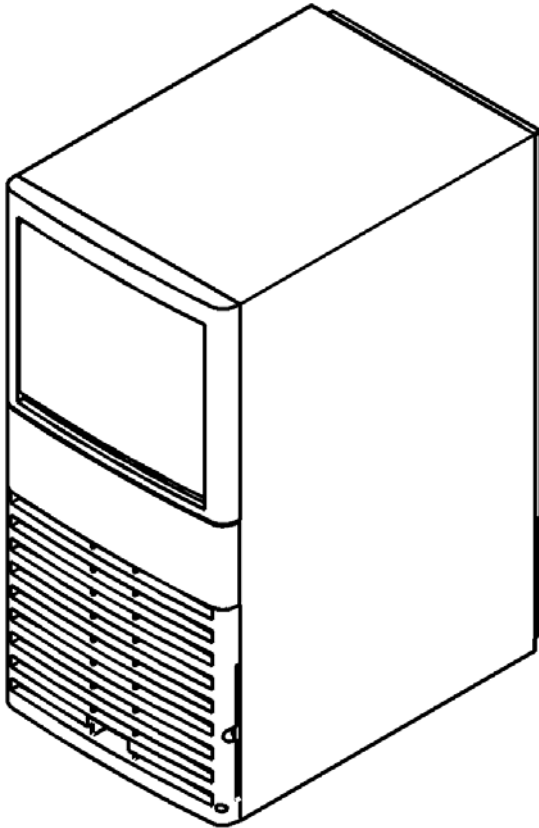

## QM20 Series Ice Machine

Installation,  
Use and Care,  
and Service Manual



Thank you for selecting a Manitowoc Ice Machine, the dependability leader in ice making equipment and related products. With proper care and maintenance, your new Manitowoc Ice Machine will provide you with many years of reliable and economical performance.

We reserve the right to make product improvements at any time.  
Specifications and design are subject to change without notice.

Part Number 000001720  
10/06

## Safety Notices

When using or servicing a QM Series Ice Machine, be sure to pay close attention to the safety notices in this manual. Disregarding the notices may lead to serious injury and/or damage to the ice machine.

Throughout this manual, you will see the following types of safety notices:

### **WARNING**

Text in a Warning box alerts you to a potential personal injury situation. Be sure to read the Warning statement, and then proceed carefully.

### **CAUTION**

Text in a Caution box alerts you to a situation in which you could damage the ice machine. Be sure to read the Caution statement, and then proceed carefully.

### **CAUTION**

Proper care and maintenance are essential for maximum ice production and trouble-free operation of your Manitowoc Ice Machine.

Read and understand this manual. It contains valuable care and maintenance information. If you encounter problems not covered by this manual, feel free to contact Manitowoc Ice, Inc. We will be happy to provide assistance.

## Procedural Notices

When using or servicing a QM Series Ice Machine, be sure to read the procedural notices in this manual. These notices supply helpful and important information.

Throughout this manual, you will see the following types of procedural notices:

### **Important**

Important boxes serve two functions.

They call the operator's attention to important information.

They also provide the service technician with information that may help perform a procedure more efficiently. Disregarding this information may slow down the work.

NOTE: Text set off as a Note provides you with simple, but useful, extra information.

**This manual covers the following model numbers:**

Self-Contained Air-Cooled: QM20A

### **Warning**

#### **Personal Injury Potential**

Do not operate equipment that has been, misused, abused, neglected, damaged, or altered/modified from that of original manufactured specifications.

Table of Contents

Section 1 - General Information

Model/Serial Number Location ..... 1-1  
Owner Warranty Registration Card..... 1-2  
Warranty Coverage ..... 1-2

Section 2 - Installation Instructions

Dimensions..... 2-1  
Location of Ice Machine ..... 2-2  
Leveling the Ice Machine..... 2-2  
Electrical Service..... 2-3  
Water Service/Drains..... 2-5

Section 3 - Ice Machine Operation

Sequence of Operation..... 3-1  
Ice Thickness Adjustment ..... 3-2

Section 4 - Maintenance

Interior cleaning and Sanitizing ..... 4-1  
Cleaning and Sanitizing Procedure..... 4-1  
Exterior Cleaning..... 4-6  
Cleaning the Condenser ..... 4-7  
Removal from Service/Winterization..... 4-8

Section 5 - Before Calling for Service

Checklist..... 5-1

# Table of Contents

---

THIS PAGE INTENTIONALLY LEFT BLANK

**Section 1  
General Information**

**Model/Serial Number Location**

Record the model and serial number of your ice machine in the space provided below. These numbers are required when requesting information from your Manitowoc distributor, service representative, or the factory.

The model and serial number are listed on the OWNER WARRANTY REGISTRATION CARD. They are also listed on the MODEL/SERIAL NUMBER DECAL affixed to the ice machine.

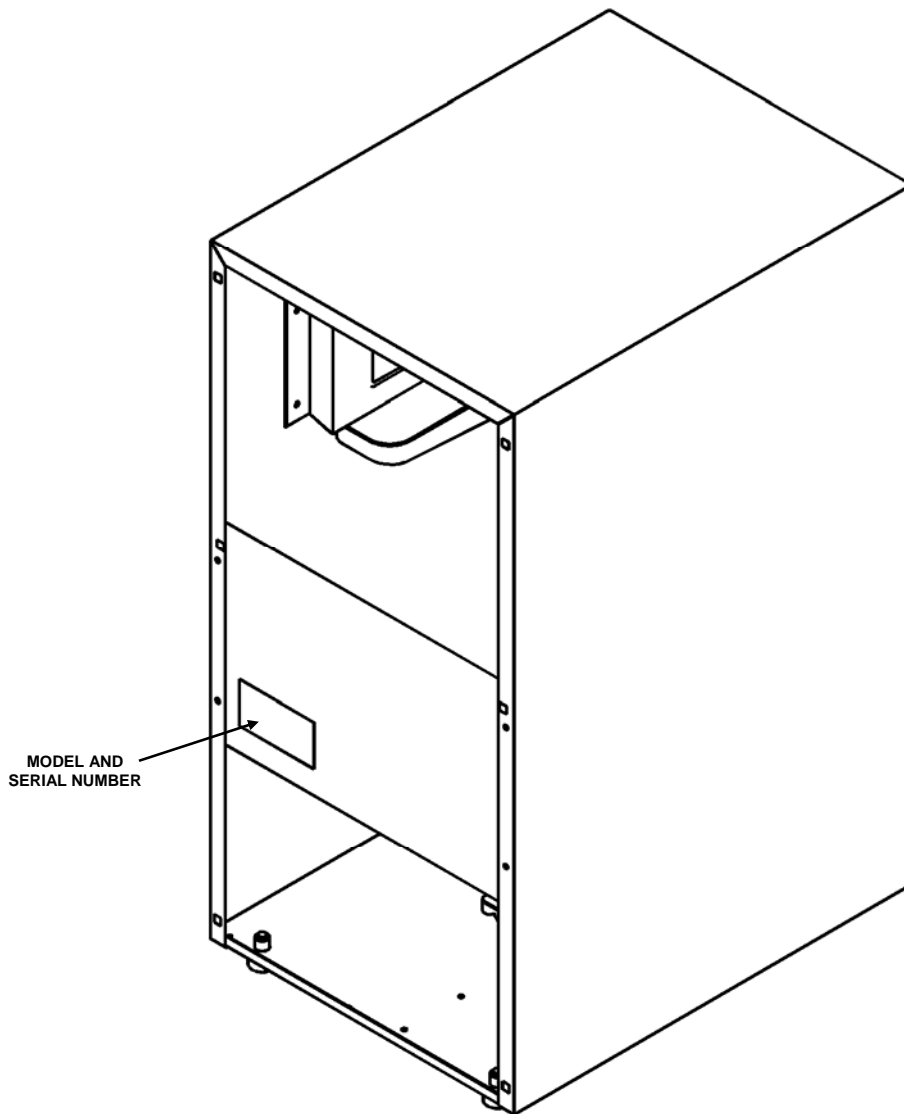

SV1702

**Model/Serial Number Location**

**MODEL NUMBER:** \_\_\_\_\_

**SERIAL NUMBER:** \_\_\_\_\_

## Owner Warranty Registration Card

### GENERAL

The packet containing this manual also includes warranty information. Warranty coverage begins the day your new ice machine is installed.

#### Important

Complete and mail the OWNER WARRANTY REGISTRATION CARD as soon as possible to validate the installation date.

If you do not return your OWNER WARRANTY REGISTRATION CARD, Manitowoc will use the date of sale to the Manitowoc Distributor as the first day of warranty coverage for your new ice machine.

## Commercial Warranty Coverage

### GENERAL

The following Warranty outline is provided for your convenience. For a detailed explanation, read the warranty bond shipped with each product.

Contact your local Manitowoc representative or Manitowoc Ice, Inc. if you need further warranty information.

### PARTS

Manitowoc warrants the ice machine against defects in materials and workmanship, under normal use and service for three (3) years from the date of original installation.

### LABOR

Labor required to repair or replace defective components is covered for three (3) years from the date of original installation.

### EXCLUSIONS

The following items are not included in the ice machine's warranty coverage:

1. Normal maintenance, adjustments and cleaning as outlined in the Owner/Operator Use and Care Guide.
2. Repairs due to unauthorized modifications to the ice machine or the use of non-standard parts without prior written approval Manitowoc Ice, Inc.
3. Damage caused by improper installation of the ice machine, electrical supply, water supply or drainage, or damage caused by floods, storms, or other acts of God.
4. Premium labor rates due to holidays, overtime, etc.; travel time; flat rate service call charges; mileage and miscellaneous tools and material charges not listed on the payment schedule. Additional labor charges resulting from the inaccessibility of the ice machine are also excluded.
5. Parts or assemblies subjected to misuse, abuse, neglect or accidents.
6. Damage or problems caused by installation, cleaning and/or maintenance procedures inconsistent with the technical instructions provided in the Installation Manual and the Owner/Operator Use and Care Guide.

### AUTHORIZED WARRANTY SERVICE

To comply with the provisions of the warranty, a refrigeration service company, qualified and authorized by a Manitowoc distributor, or a Contracted Service Representative must perform the warranty repair.

NOTE: If the dealer the ice machine was purchased from is not authorized to perform warranty service, contact the Manitowoc distributor or Manitowoc Ice, Inc. for the name of the nearest authorized service representative.

### Service Calls

If you have followed the procedures listed in Section 5 of this manual, and the ice machine still does not perform properly, call your authorized service company.

## Residential Warranty Coverage

### WHAT DOES THIS LIMITED WARRANTY COVER?

Subject to the exclusions and limitations below, Manitowoc Ice, Inc. (“Manitowoc”) warrants to the original consumer that any new ice machine manufactured by Manitowoc (the “Product”) shall be free of defects in material or workmanship for the warranty period outlined below under normal use and maintenance, and upon proper installation and start-up in accordance with the instruction manual supplied with the Product.

### HOW LONG DOES THIS LIMITED WARRANTY LAST?

Ice Machine - Twelve (12) months from the sale date

### WHO IS COVERED BY THIS LIMITED WARRANTY?

This limited warranty only applies to the original consumer of the Product and is not transferable.

### WHAT ARE MANITOWOC ICE’S OBLIGATIONS UNDER THIS LIMITED WARRANTY?

If a defect arises and Manitowoc receives a valid warranty claim prior to the expiration of the warranty period, Manitowoc shall, at its option: (1) repair the Product at Manitowoc’s cost, including standard straight time labor charges, (2) replace the Product with one that is new or at least as functionally equivalent as the original, or (3) refund the purchase price for the Product. Replacement parts are warranted for 90 days or the balance of the original warranty period, whichever is longer. The foregoing constitutes Manitowoc’s sole obligation and the consumer’s exclusive remedy for any breach of this limited warranty. Manitowoc’s liability under this limited warranty is limited to the purchase price of Product. Additional expenses including, without limitation, service travel time, overtime or premium labor charges, accessing or removing the Product, or shipping are the responsibility of the consumer.

### HOW TO OBTAIN WARRANTY SERVICE

To obtain warranty service or information regarding your Product, please contact us at:

MANITOWOC ICE, INC.

2110 So. 26<sup>th</sup> St.,

P.O. Box 1720,

Manitowoc, WI 54221-1720

Telephone: 920-682-0161 Fax: 920-683-7585

www.manitowocice.com

### WHAT IS NOT COVERED?

This limited warranty does not cover, and you are solely responsible for the costs of: (1) periodic or routine maintenance, (2) repair or replacement of the Product or parts due to normal wear and tear, (3) defects or damage to the Product or parts resulting from misuse, abuse, neglect, or accidents, (4) defects or damage to the Product or parts resulting from improper or unauthorized alterations, modifications, or changes; and (5) defects or damage to any Product that has not been installed and/or maintained in accordance with the instruction manual or technical instructions provided by Manitowoc. To the extent that warranty exclusions are not permitted under some state laws, these exclusions may not apply to you.

EXCEPT AS STATED IN THE FOLLOWING SENTENCE, THIS LIMITED WARRANTY IS THE SOLE AND EXCLUSIVE WARRANTY OF MANITOWOC WITH REGARD TO THE PRODUCT. ALL IMPLIED WARRANTIES ARE STRICTLY LIMITED TO THE DURATION OF THE LIMITED WARRANTY APPLICABLE TO THE PRODUCTS AS STATED ABOVE, INCLUDING BUT NOT LIMITED TO, ANY WARRANTY OF MERCHANTABILITY OR OF FITNESS FOR A PARTICULAR PURPOSE. Some states do not allow limitations on how long an implied warranty lasts, so the above limitation may not apply to you.

IN NO EVENT SHALL MANITOWOC OR ANY OF ITS AFFILIATES BE LIABLE TO THE CONSUMER OR ANY OTHER PERSON FOR ANY INCIDENTAL, CONSEQUENTIAL OR SPECIAL DAMAGES OF ANY KIND (INCLUDING, WITHOUT LIMITATION, LOSS OF PROFITS, REVENUE OR BUSINESS) ARISING FROM OR IN ANY MANNER CONNECTED WITH THE PRODUCT, ANY BREACH OF THIS LIMITED WARRANTY, OR ANY OTHER CAUSE WHATSOEVER, WHETHER BASED ON CONTRACT, TORT OR ANY OTHER THEORY OF LIABILITY. Some states do not allow the exclusion or limitation of incidental or consequential damages, so the above limitation or exclusion may not apply to you.

### HOW STATE LAW APPLIES

This limited warranty gives you specific legal rights, and you may also have rights that vary from state to state or from one jurisdiction to another.

### REGISTRATION CARD

To secure prompt and continuing warranty service, this warranty registration card must be completed and sent to Manitowoc within thirty (30) days from the sale date. Complete the following registration card and send it to Manitowoc at the address shown.

INTENTIONALLY LEFT BLANK



Section 2  
Installation Instructions

Dimensions

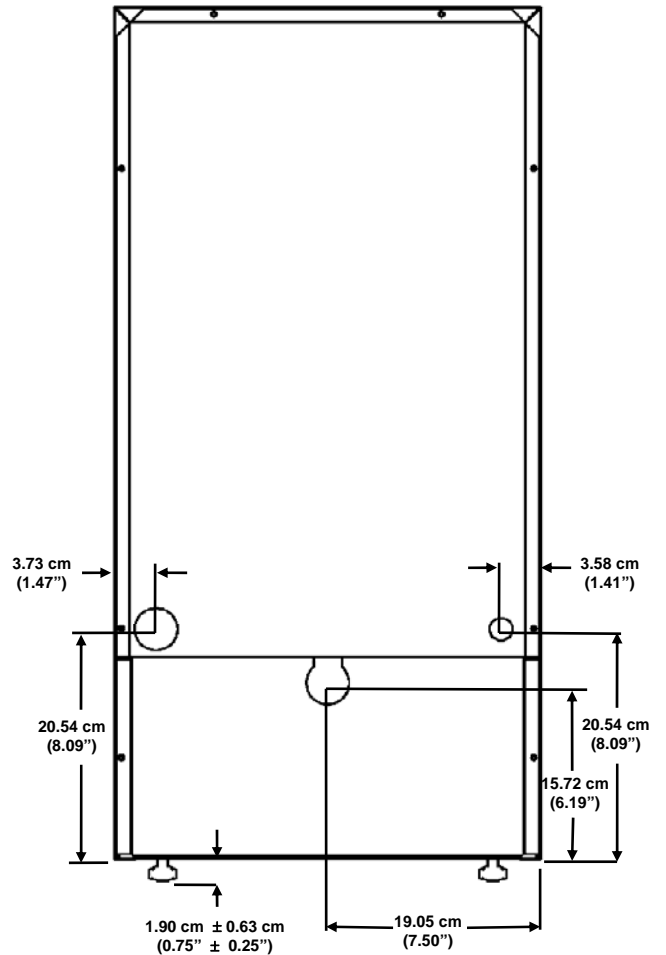
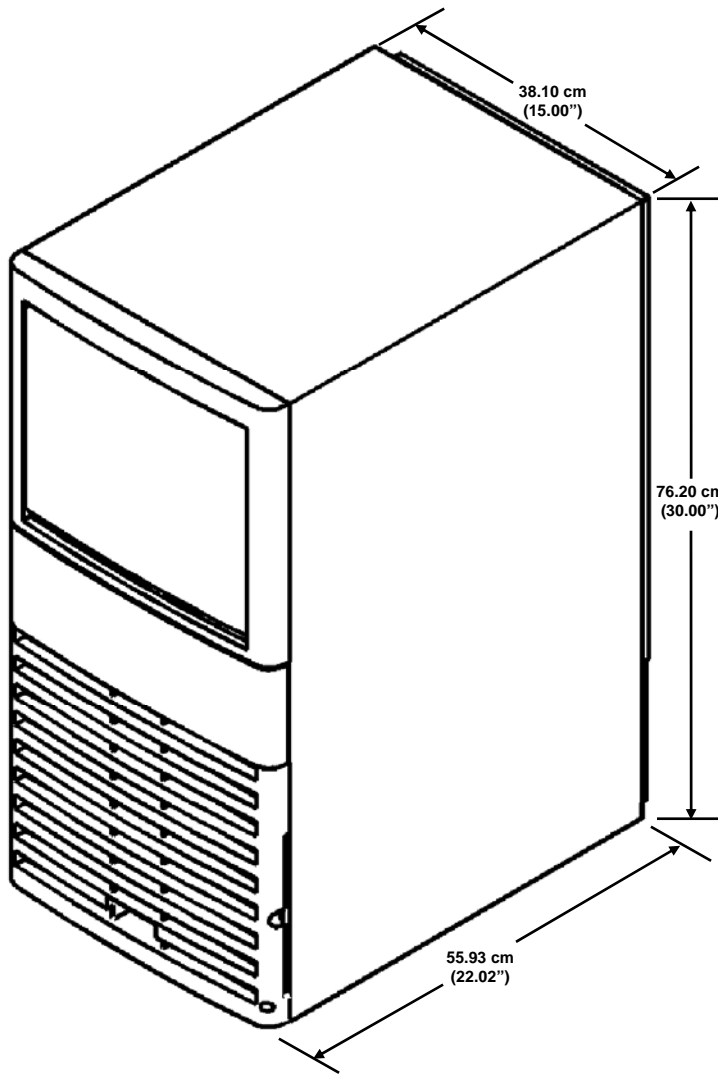

SV1717

## Location of Ice Machine

The location selected for the ice machine must meet the following criteria. If any of these criteria are not met, select another location.

- The location must be indoors.
- The location must be free of airborne and other contaminants.
- The air temperature must be at least 10°C (50°F), but must not exceed 40°C (110°F).
- The location must not be near heat-generating equipment or in direct sunlight.
- The counter top (or other resting surface) must be able to support 425 kg per square meter (0.6 lb. per square inch).
- The location must allow enough clearance for water, drain, and electrical connections in the **rear of the ice machine**.
- The location must not obstruct air flow to any portion of the **front of the ice machine**.

**! CAUTION**

The ice machine must be protected if it will be subjected to temperatures below 0°C (32°F). Failure caused by exposure to freezing temperatures is not covered by the warranty. See “Removal from Service/Winterization” on page 4-8.

Self-Contained Air-Cooled	
Top/Sides	203 mm (5")*
Back	127 mm (5")*

NOTE: The ice machine may be built into a cabinet. There is no minimum clearance requirement for the top or the left and right sides of the ice machine

## Ice Machine Heat of Rejection

Series Ice Machine	Heat of Rejection*	
	Air Conditioning**	Peak
QM20	1450	2100

\* B.T.U./Hour

\*\* Because the heat of rejection varies during the ice making cycle, the figure shown is an average.

Ice machines, like other refrigeration equipment, reject heat through the condenser. It is helpful to know the amount of heat rejected by the ice machine when sizing air conditioning equipment where self-contained air-cooled ice machines are installed.

## Leveling the Ice Machine

After moving the ice machine into the installation location, it must be leveled for proper operation. Follow these steps to level the ice machine:

1. Check the level of the ice machine from front to back and from side to side.

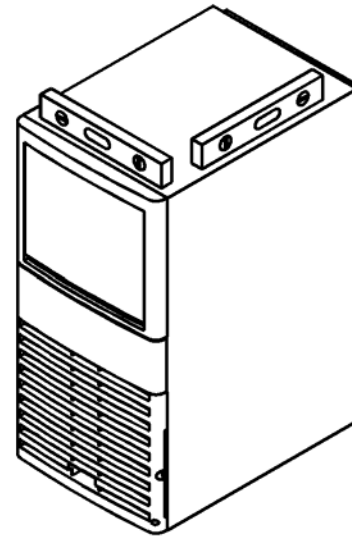

SV1704

### Checking for Level

2. If the ice machine is not level, adjust the leveling glides on each corner of the base of the ice machine as necessary.
3. Check the level of the ice machine after each adjustment of the leveling glides.
4. Repeat steps 2 and 3 until the ice machine is level from front to back and from side to side.

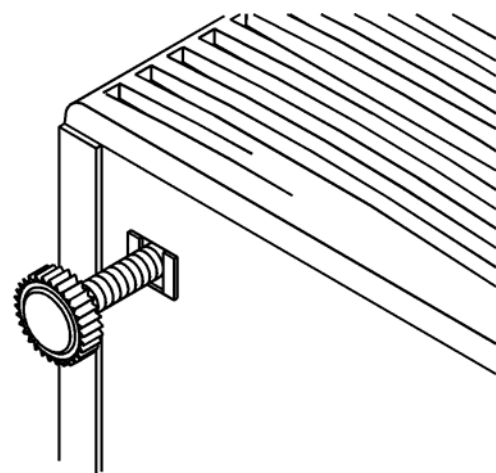

Leveling Glide

SV1705

Electrical Service

GENERAL

**⚠ WARNING**  
 All wiring must conform to local, state and national codes.

**⚠ WARNING**  
 Never use an extension cord. If an outlet is not within reach of the ice machine’s power cord, have a proper amperage outlet wired closer to the ice machine.

Voltage Phase Cycle	Air-Cooled Electrical Rating
230/50/1	0.3 KW / 1.5 Amps
115/60/1	0.4KW / 3.5 Amps

**VOLTAGE**

The maximum allowable voltage variation is ± 10% of the rated voltage at ice machine start-up (when the electrical load is highest).

**⚠ WARNING**  
 The ice machine must be grounded in accordance with national and local electrical codes.

**FUSE/CIRCUIT BREAKER**

A separate fuse/circuit breaker must be provided for each ice machine.

NOTE: A disconnect means must be provided for field wiring.

**ELECTRICAL RATING**

The electrical rating is used to help select the wire size of the electrical supply. The wire size (or gauge) also depends on location, materials used, length of run, etc., so it must be determined by a qualified electrician.

**FOR UNITED KINGDOM ONLY**

As the colours of the wires in the mains lead of the appliance may not correspond with the coloured markings identifying the terminals in your plug, proceed as follows:

- The wire which is coloured green and yellow must be connected to the terminal in the plug which is marked with the letter E or by the earth symbol  $\perp$ , or coloured green or green and yellow.
- The wire coloured blue must be connected to the terminal which is marked with the letter N or coloured black.
- The wire which is coloured brown must be connected the terminal which is marked with the letter L or coloured red.

## ELECTRICAL CORD STRAIN RELIEF

To prevent strain at the electrical connection inside the ice machine, an electrical cord strain relief device must be installed on the rear panel of the ice machine.

1. Disassemble the strain relief device into its three components.
2. Install the cord holder through the opening in the lower right corner of the rear panel of the ice machine.

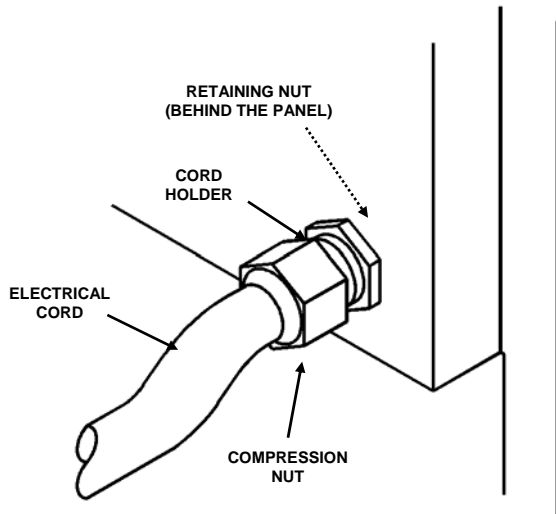

SV1706

### Strain Relief Installation

3. Hand-tighten the retaining nut onto the cord holder from inside the ice machine rear panel.
4. Slide the compression nut over the electrical cord.
5. Feed about 1.5 m (5 ft.) of electrical cord through the cord holder. (The extra cord will allow the rear panel to be removed for future service.)
6. Hand-tighten the compression nut onto the cord holder.

## TERMINAL BLOCK WIRE CONNECTION

### WARNING

Always disconnect power to the ice machine before working on electrical circuitry.

After the electrical cord is installed in the strain relief device, the cord must be connected to the terminal block to supply power to the ice machine.

1. Remove two Phillips head screws to remove the lower panel from the front of the ice machine.
2. Carefully reach into the ice machine and pull the electrical cord forward to the terminal block.
3. Strip away enough insulation from the electrical cord to allow for good electrical connections at the terminal block.

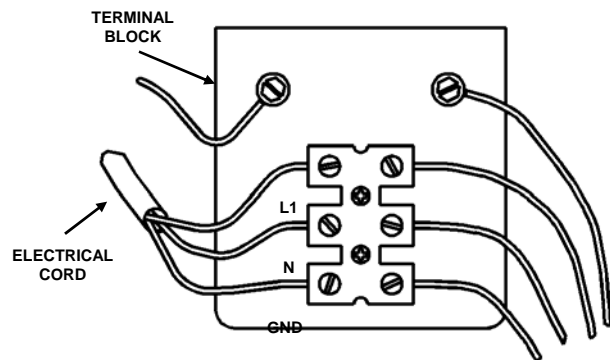

SV1707

### Terminal Block Connections

4. Open the screw terminals on the terminal block.
5. Connect each wire in the electrical cord to the appropriate screw terminal.
6. Carefully tighten the screws over the wire.
7. Tug lightly on each wire to be sure the connections are secure.

## Water Service/Drains

### WATER SUPPLY

Local water conditions may require treatment of the water to inhibit scale formation, filter sediment, and remove chlorine odor and taste.

#### Important

If you are installing a Manitowoc water filter system, refer to the Installation Instructions supplied with the filter system for ice making water inlet connections.

Follow these guidelines to install water inlet lines:

- Connect to potable water supply only.
- Do not connect the ice machine to a hot water supply. Be sure all hot water restrictors installed for other equipment are working. (Check valves on sink faucets, dishwashers, etc.)
- If water pressure exceeds the maximum recommended pressure, obtain a water pressure regulator from your Manitowoc distributor.

- Install a water shut-off valve for both the ice making and condenser water lines (if applicable).
- Insulate water lines to prevent condensation.

#### Important

The water inlet line is connected to the water valve. This valve is located just behind the front panel of the ice machine.

### DRAIN CONNECTIONS

Follow these guidelines when installing drain lines to prevent drain water from flowing back into the ice machine and storage bin:

- Drain lines must have a 2.5 cm (1 inch) drop per 1 meter (40 inches) of run, and must not create traps.
- The floor drain must be large enough to accommodate drainage from all drains.
- Insulate the bin drain line to prevent condensation.

## WATER SUPPLY AND DRAIN LINE SIZING/CONNECTIONS



### CAUTION

Plumbing must conform to state and local codes.

	Water Temperature	Water Pressure	Ice Machine Fitting	Tubing Size Up to Ice Machine Fitting
Ice Making Water Inlet	10°C (50°F) Min. <sup>1</sup> 30°C (86°F) Max. <sup>2</sup>	2.4 bar (35 psi) Min. <sup>1</sup> 6.2 bar (90 psi) Max. <sup>2</sup>	3/4" male hose connection <sup>3</sup>	0.95 cm (3/8") minimum inside diameter
Ice Making/Bin Water Drain	---	---	1.59 cm (5/8") inside diameter flexible hose	1.59 cm (5/8") minimum inside diameter

<sup>1</sup> Min. = Minimum

<sup>2</sup> Max. = Maximum

<sup>3</sup> A 3/4" by 11-1/2 threads per inch to 14 threads per inch adapter is factory installed. Remove this adapter if 11-1/2 threads per inch connection is desired.

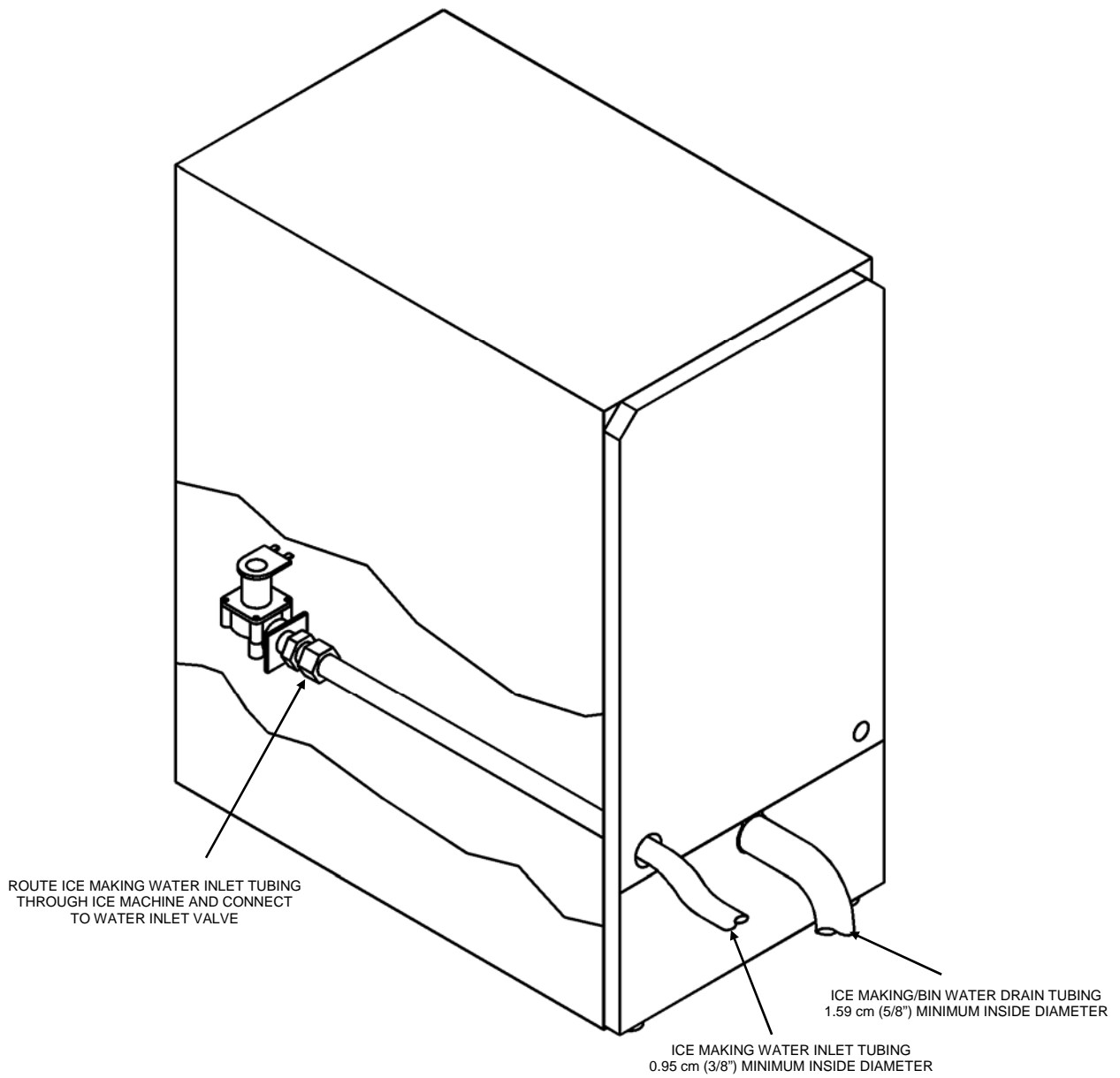

**Typical Water Supply and Drain Line Sizing and Connections**

## Section 3 Ice Machine Operation

### Sequence of Operation

Ice Making Sequence of Operation	Control Board Relays			Length of "ON" Time
	1 Compressor	2 Hot Gas Valve Water Fill Valve	3 Water Pump Fan Motor	
Start-Up <sup>1</sup>	Off	On	Off	2.9 Minutes (175 Seconds)
1. Water Purge	On	On	Off	5 Seconds
2. Refrigeration System Start-Up	On	Off	On	Automatically determined
3. Freeze Cycle	On	On	Off	Automatically determined
4. Harvest Cycle	Off	Off	Off	Until bin thermostat re-closes
5. Auto Shut-Off				

<sup>1</sup> Initial Start-Up or Start-Up After Automatic Shut-Off

#### INITIAL START-UP OR START-UP AFTER AUTOMATIC SHUT-OFF

##### 1. Water Purge

The water fill valve and the hot gas valve are energized for 2.9 minutes (175 seconds). This ensures that the ice making cycle starts with fresh water, and that the refrigerant pressures are equalized prior to refrigeration system start-up.

##### 2. Refrigeration System Start-Up

The compressor starts 2.9 minutes (175 seconds) after the water fill valve and hot gas valve are energized. (The water fill valve and hot gas valve remain energized for 5 seconds during compressor start-up, and then shut off.) The compressor remains on throughout the entire freeze and harvest cycles.

##### 3. FREEZE CYCLE

The condenser fan motor and water pump are energized and remain on throughout the entire freeze cycle. An even flow of water is directed across the evaporator and into each cube cell, where it freezes.

The control system automatically determines the length of the freeze cycle by monitoring the temperature of the refrigeration system liquid line.

##### 4. HARVEST CYCLE

The condenser fan motor and water pump de-energize. The water fill valve energizes to purge the water in the water trough. The hot gas valve also energizes at the beginning of the harvest cycle to divert hot refrigerant gas into the evaporator. The hot refrigerant gas warms the evaporator, causing the cubes to slide, as a sheet, off the evaporator and into the ice storage bin.

The control system automatically determines the length of the harvest cycle, based on the temperature of the refrigeration system liquid line at the end of the freeze cycle. At the end of the harvest cycle, the ice machine returns to another freeze cycle (step 3, above).

##### 5. AUTOMATIC SHUT-OFF

The ice machine shut-off is controlled by the level of ice in the ice storage bin. When the bin is full, ice cubes contact the bin thermostat bulb holder, which cools down and opens to stop the ice machine. The ice machine remains off until enough ice has been removed from the bin. This causes the thermostat bulb holder to warm and close, restarting the ice machine. When the ice machine restarts, it returns to the start-up sequence (steps 1 and 2, above).

## Ice Thickness Adjustment

QM-20 dice ice cube formation is slightly different from our previous models. Manitowoc ice machines have a unique cube shape. It is normal to have a dimple in the ice cube (a concave indentation in the cube). Ice cubes from the QM-20 may appear to have a slightly larger dimple than other Manitowoc dice cube machines. Therefore, cube size for the QM-20 is determined by measuring the slab weight (the combined weight of all cubes from one harvest cycle). To determine proper slab weight follow the instructions listed below.

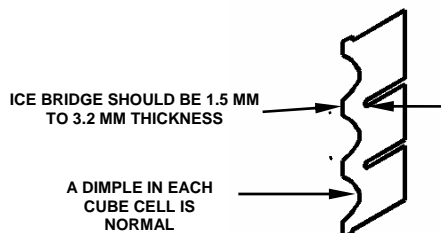

### Correct Ice Bridge Thickness

1. Ensure the air filter, front, and back panels are installed properly and close the bin door.
2. During the **third** harvest cycle open the bin door and catch the entire slab of ice.
3. Weigh the ice slab. The combined weight of all cubes from one harvest should weigh between 200 - 270g (7 - 9-oz). If the slab weight is within this range, the ice machine is working properly and no further action is needed. If the slab weight is not within this range or you desire a slightly thicker or thinner cube, continue to step four.



### WARNING

Do not touch electrical wires. Disconnect power to the ice machine before making any ice thickness adjustments.

4. Remove the air filter.
5. Remove the two screws holding the front panel in place and remove the front cover.
6. Locate the ice thickness control dial on the control board (see below). Turn the dial clockwise for a thicker cube or counter clockwise for a thinner cube.

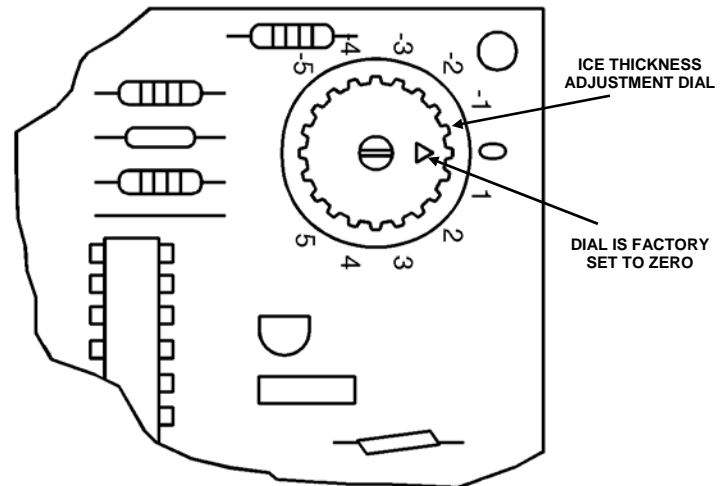

sv1710

### Ice Thickness Adjustment Dial

7. Assure all of the panels and air filter are reinstalled properly and the bin door is closed. Repeat steps one through three.

After completing the procedure above, if you are unable to obtain a sheet of ice weighing 200 - 270g (7 - 9-oz) contact the Manitowoc Service Department for further assistance.



## Section 4 Maintenance

### Interior Cleaning and Sanitizing

#### GENERAL

You are responsible for maintaining the ice machine in accordance with the instructions in this manual. Maintenance procedures are not covered by the warranty.

Clean and sanitize the ice machine every six months for efficient operation. If the ice machine requires more frequent cleaning and sanitizing, consult a qualified service company to test the water quality and recommend appropriate water treatment.

The ice machine must be taken apart for cleaning and sanitizing.

 **CAUTION**

Use only Manitowoc approved Ice Machine Cleaner (part number 94-0546-3) and Sanitizer (part number 94-0565-3). It is a violation of Federal law to use these solutions in a manner inconsistent with their labeling. Read and understand all labels printed on bottles before use.

#### CLEANING AND SANITIZING PROCEDURE

 **CAUTION**

Do not mix Ice Machine Cleaner and Sanitizer solutions together. It is a violation of Federal law to use these solutions in a manner inconsistent with their labeling.

 **WARNING**

Wear rubber gloves and safety goggles (and/or face shield) when handling Ice Machine Cleaner or Sanitizer.

Ice machine cleaner is used to remove lime scale and mineral deposits. Ice machine sanitizer disinfects and removes algae and slime.

**Step 1** Set the toggle switch to the OFF position after ice falls from the evaporator at the end of a Harvest cycle. Or, set the switch to the OFF position and allow the ice to melt off the evaporator.

 **CAUTION**

Never use anything to force ice from the evaporator. Damage may result.

**Step 2** Remove all ice from the bin.

**Step 3** To start a cleaning cycle, move the toggle switch to the WASH position.

**Step 4** Wait until water flows over the evaporator (about three minutes) then add the proper amount of Manitowoc Ice Machine Cleaner to the water trough.

Model	Amount of Cleaner
QM20	30 ml (1 ounce)

**Step 5** Wait until the clean cycle is complete (approximately 45 minutes) then place the toggle switch in the OFF position, disconnect power and water supplies to the ice machine.

**⚠ WARNING**

Disconnect electric power to the ice machine at the electric switch box before proceeding.

**Step 6:** Remove parts for cleaning.

**A. Remove the Bin Door**

- Grasp the rear of the bin door and pull bin door forward approximately 5”.
- Slide bin door to the rear while applying upward pressure (The rear door pins will ride up into the track slot and slide backward to the stop tab).
- While applying pressure against the bin door pull down on the rear of each bin door track until the door pins clear the stop tabs.
- Slide the rear door pins off the end and then below the door track. Slide bin door forward allowing the back of the door to lower into the bin. Continue forward with the bin door until the front pins bottom out in the track.
- Lift right side of door until the front pins clear the track, then remove door from bin.

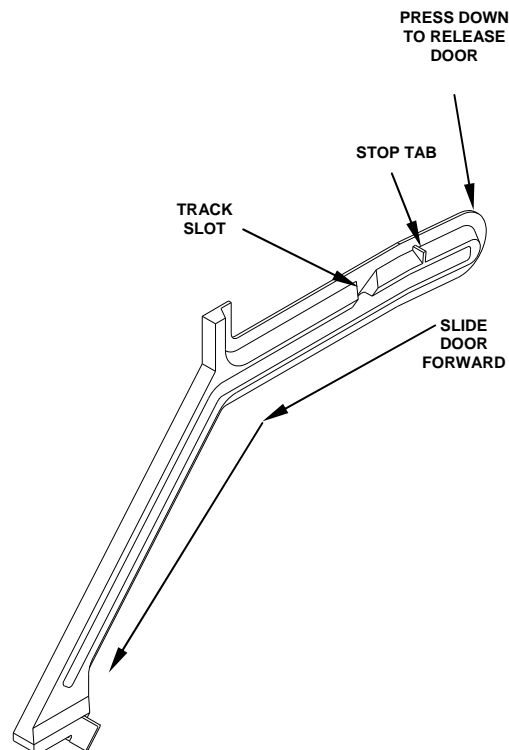

Parts Removal Overview

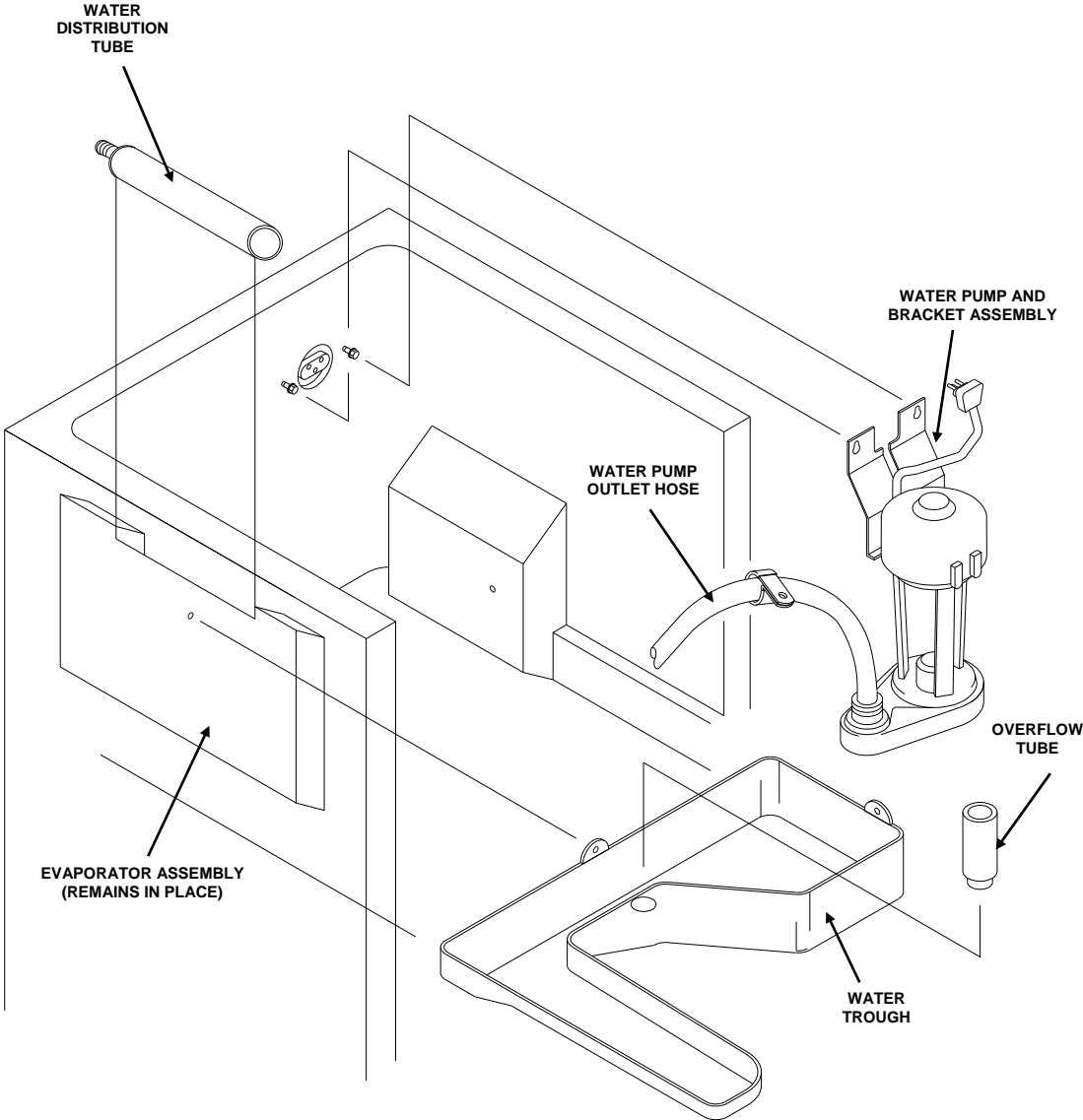

## B. Remove the Overflow Tube

- To remove the tube, lift it up while using a slight back and forth motion to loosen it from the drain hole.

When installing the tube, be sure it is completely inserted into the drain hole to prevent water leakage during normal operation.

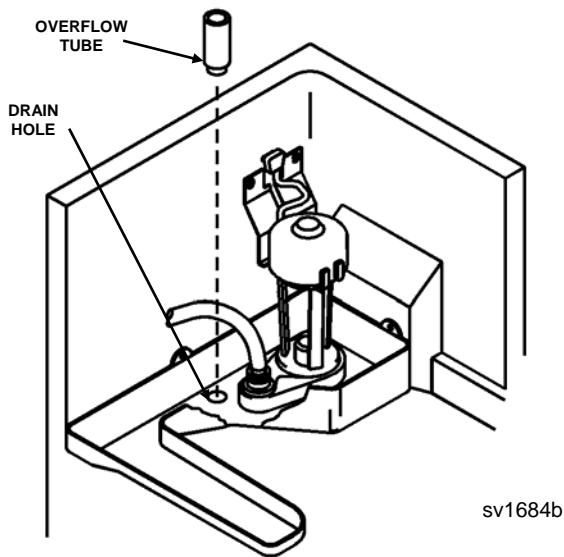

**Removing the Overflow Tube**

## C. Remove the Vinyl Hose

- Disconnect the water pump discharge hose from the distribution tube and water pump.

## D. Remove the Water Pump

- Disconnect the water pump power cord.
- Disconnect the water hose from the pump outlet.
- Loosen the screws that hold the water pump in place.
- Lift the water pump and bracket assembly up and off the screws.

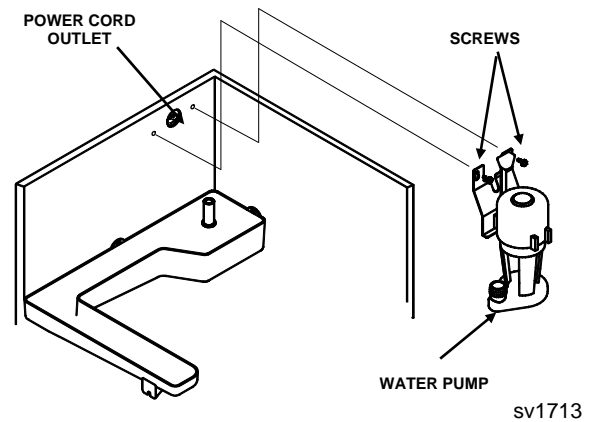

**Removing the Water Pump**

## E. Remove the Water Trough

- Remove the screws holding the water trough to the walls of the cabinet.

**Step 7** Mix a solution of cleaner and warm water. Depending on the amount of mineral buildup, a larger quantity of solution may be required. Use the ratio in the table below to mix enough solution to thoroughly clean all parts.

Solution Type	Water	Mixed with
Cleaner	4L. (1 gall)	500 ml (16 oz) cleaner

**Step 8** Use 1/2 of the cleaner/water solution to clean all components. The cleaner solution will foam when it contacts lime scale and mineral deposits; once the foaming stops use a soft bristle brush, sponge or cloth (not a wire brush) to carefully clean the parts. Soak the parts for 5 minutes (15 – 20 minutes for heavily scaled parts). Rinse all components with clean water.

**Step 9** While components are soaking, use 1/2 of the cleaner/water solution to clean all foodzone surfaces of the ice machine and bin. Use a nylon brush or cloth to thoroughly clean the following ice machine areas:

- Evaporator plastic parts – including top, bottom and sides
- Bin bottom, sides and top

Rinse all areas thoroughly with clean water.

**Step 10** Mix a solution of sanitizer and warm water.

Solution Type	Water	Mixed With
Sanitizer	23 L. (6 gal )	120 ml (4 ounces) sanitizer

**Step 11** Use 1/2 of the sanitizer/water solution to sanitize all removed components. Use a cloth or sponge to liberally apply the solution to all surfaces of the removed parts or soak the removed parts in the sanitizer/water solution. Do not rinse parts after sanitizing.

**Step 12** Use 1/2 of the sanitizer/water solution to sanitize all foodzone surfaces of the ice machine and bin. Use a cloth or sponge to liberally apply the solution. When sanitizing, pay particular attention to the following areas:

- Evaporator plastic parts - including top, bottom and sides
- Bin bottom, sides and top

Do not rinse the sanitized areas.

**Step 13** Replace all removed components.

**Step 14** Reapply power and water to the ice machine and place the toggle switch in the WASH position.

**Step 15** Add the proper amount of Manitowoc Ice Machine Sanitizer to the water trough.

Model	Amount of Sanitizer
QM20	45 ml (1.5 oz)

**Step 16** Wait until the sanitize cycle is complete (approximately 45 minutes) then place the toggle switch in the OFF position, disconnect power and water supplies to the ice machine.



## WARNING

Disconnect electric power to the ice machine at the electric switch box before proceeding.

**Step 17** Repeat step 6 to remove parts for hand sanitizing.

**Step 18** Mix a solution of sanitizer and warm water.

Solution Type	Water	Mixed With
Sanitizer	23L. (6 gal )	120 ml (4 oz) sanitizer

**Step 19** Use 1/2 of the sanitizer/water solution to sanitize all removed components. Use a cloth or sponge to liberally apply the solution to all surfaces of the removed parts or soak the removed parts in the sanitizer/water solution. Do not rinse parts after sanitizing.

**Step 20** Use 1/2 of the sanitizer/water solution to sanitize all foodzone surfaces of the ice machine and bin. Use a cloth or sponge to liberally apply the solution. When sanitizing, pay particular attention to the following areas:

- Evaporator plastic parts - including top, bottom and sides
- Bin bottom, sides and top

Do not rinse the sanitized areas.

**Step 21** Replace all removed components.

**Step 22** Reapply power and water to the ice machine and place the toggle switch in the ICE position.

## EXTERIOR CLEANING

Clean the area around the ice machine as often as necessary to maintain cleanliness and efficient operation.

Sponge any dust and dirt off the outside of the ice machine with mild soap and water. Wipe dry with a clean, soft cloth.

Treat all exterior stainless steel surfaces with a commercial grade stainless steel cleaner/polish.

## ICE MACHINE INSPECTION

Check all water fittings and lines for leaks. Also, make sure the refrigeration tubing is not rubbing or vibrating against other tubing, panels, etc.

Do not put anything (boxes, etc.) in front of the ice machine. There must be adequate airflow through and around the ice machine to maximize ice production and ensure long component life.

**CLEANING THE CONDENSER****WARNING**

Disconnect electric power to the ice machine at the electric service switch before cleaning the condenser.

**Air-Cooled Condenser**

A dirty condenser restricts airflow, resulting in excessively high operating temperatures. This reduces ice production and shortens component life. Clean the condenser at least every six months. Follow the steps below.

**WARNING**

The condenser fins are sharp. Use care when cleaning them.

1. The washable aluminum filter on self-contained ice machines is designed to catch dust, dirt, lint and grease. This helps keep the condenser clean. Clean the filter with a mild soap and water solution.

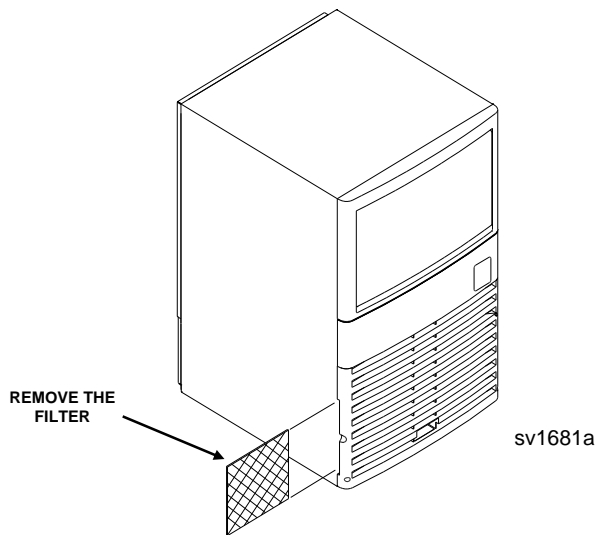

**Removing the Filter**

Clean the outside of the condenser with a soft brush or a vacuum with a brush attachment. Clean from top to bottom, not side to side. Be careful not to bend the condenser fins.

2. Shine a flashlight through the condenser to check for dirt between the fins. If dirt remains: Blow compressed air through the condenser fins from the inside. Be careful not to bend the fan blades.
3. Use a commercial condenser coil cleaner. Follow the directions and cautions supplied with the cleaner.
4. Straighten any bent condenser fins with a fin comb.
5. Carefully wipe off the fan blades and motor with a soft cloth. Do not bend the fan blades. If the fan blades are excessively dirty, wash with warm, soapy water and rinse thoroughly.

**CAUTION**

If you are cleaning the condenser fan blades with water, cover the fan motor to prevent water damage.

## Removal from Service/Winterization

### GENERAL

Special precautions must be taken if the ice machine is to be removed from service for an extended period of time or exposed to ambient temperatures of 0°C (32°F) or below.



### CAUTION

If water is allowed to remain in the ice machine in freezing temperatures, severe damage to some components could result. Damage of this nature is not covered by the warranty.

1. Disconnect the electric power at the circuit breaker or the electric service switch.
2. Turn off the water supply.
3. Remove the water from the water trough.
4. Disconnect the drain and the incoming ice-making water line at the rear of the ice machine.
5. Make sure no water is trapped inside the ice machine incoming water lines, drain lines, distribution tubes, etc. Blow compressed air through the line if necessary.



## Section 5 Before Calling for Service

### Checklist

If a problem arises during operation of your ice machine, follow the checklist below before calling for service.

Problem	Possible Cause	To Correct
Ice machine does not operate.	No electrical power to the ice machine.	Replace the fuse/reset the breaker/turn on the main switch.
	Toggle switch set improperly.	Move the toggle switch to the ON position.
	Low air temperature around ice machine.	Air temperature must be at least 10°C (50°F).
Ice machine does not release ice or is slow to harvest.	Ice machine is dirty.	Clean and sanitize the ice machine. See pages 4-3 and 4-4.
	Ice machine is not level.	Level the ice machine. See page 2-2.
	Low air temperature around ice machine (air-cooled models).	Air temperature must be at least 10°C (50°F).
Ice quality is poor (soft or not clear).	Poor incoming water quality.	Contact a qualified service company to test the quality of the incoming water and make appropriate filter recommendations.
	Water filtration is poor.	Replace the filter.
	Ice machine is dirty.	Clean and sanitize the ice machine. See pages 4-3 and 4-4.
	Water inlet valve filter screen is dirty.	Remove the water inlet valve and clean the filter screen. See page 4-6.
	Water softener is working improperly (if applicable).	Repair the water softener.

*Continued on next page...*

Problem	Possible Cause	To Correct
Ice machine produces shallow or incomplete cubes, or the ice fill pattern on the evaporator is incomplete.	Water level is low.	Be sure the overflow tube is fully seated to prevent water leakage. See page 4-5.
	Water inlet valve filter screen is dirty.	Remove the water inlet valve and clean the filter screen. See page 4-6.
	Water filtration is poor.	Replace the filter.
	Hot incoming water.	Connect the ice machine to a cold water supply. See page 2-5.
	Ice thickness adjustment dial is not set properly.	Adjust the ice thickness adjustment dial. See page 3-2.
	Incorrect incoming water pressure.	Water pressure must be 240-620 kPa (34.8 - 89.9 psi).
	Ice machine is not level.	Level the ice machine. See page 2-2.
Low ice capacity.	Water inlet valve filter screen is dirty.	Remove the water inlet valve and clean the filter screen. See page 4-6.
	Incoming water supply is shut off.	Open the water service valve.
	The air filter is dirty.	Clean the air filter. See page 4-1.
	The condenser is dirty.	Clean the condenser. See page 4-1.
	Inadequate airflow at the front of the ice machine.	Remove items blocking airflow at the front of the ice machine.
	Ice thickness adjustment dial is not set properly.	Adjust the ice thickness adjustment dial. See page 3-2.



**MANITOWOC ICE, INC.**

2110 South 26th Street P.O. Box 1720

Manitowoc, WI 54221-1720

Phone: (920) 682-0161

Fax: (920) 683-7585

Web Site - [www.manitowocice.com](http://www.manitowocice.com)

©2006 Manitowoc Ice, Inc.