

OPERATOR'S MANUAL

AF044X-XX AF046X-XX

INCLUDING: SERVICE KITS, TROUBLESHOOTING, PARTS LIST,
DISASSEMBLY & REASSEMBLY.

RELEASED: 8-16-10
REVISED: 8-10-12
(REV. 02)

4-1/4" AIR MOTORS AF044X-XX (4" STROKE) and AF046X-XX (6" STROKE) Also covers 637489 service kits



**READ THIS MANUAL CAREFULLY BEFORE INSTALLING,
OPERATING OR SERVICING THIS EQUIPMENT.**

It is the responsibility of the employer to place this information in the hands of the operator. Keep for future reference.

THIS MANUAL COVERS THE FOLLOWING MODELS

MODEL						
AF0441-XX	AF0442-XX	AF0443-XX	AF0444-XX	AF0445-XX	AF0460-XX	

SERVICE KITS

- Use only genuine ARO® replacement parts to assure compatible pressure rating and longest service life.
- 637489 for general repair of all air motors.

GENERAL DESCRIPTION

⚠ WARNING DO NOT EXCEED MAXIMUM OPERATING PRESSURE AS INDICATED ON PUMP MODEL PLATE.

⚠ WARNING REFER TO GENERAL INFORMATION SHEET FOR ADDITIONAL SAFETY PRECAUTIONS AND IMPORTANT INFORMATION.

- This manual only covers the air motor section. It is one of four documents which support an ARO pump. Replacement copies of these forms are available upon request.
 - Pump Model Operator's Manual.
 - General Information for Air Operated or Hydraulically Operated Pumps.
 - Lower Pump End Operator's Manual.
 - Air or Hydraulic Motor Operator's Manual.
- The 4-1/4" air motor is a general purpose power unit and is used with many 2-ball, 4-ball, and chop check pumps. It utilizes tie rod type construction for easy breakdown and it connects to the various lower ends via tie rods for easy operation. Consult pump model operator's manual for specific instructions.

MODEL DESCRIPTION CHART

A F 04 X X - XX	
Air Motor Diameter 04 - 4 1/4"	
Stroke Length 4 - 4", 6 - 6"	
Air Motor Base/Rod Combination 0 - Divorced pump base with quick coupled rod connection 1 - Divorced pump base with pinned coupled rod connection 2 - Coupled pump base with pinned coupled rod connection 3 - Coupled pump base with male threaded rod connection 4 - Coupled pump base with female threaded rod connection 5 - Coupled high pressure pump base with female threaded rod connection (See Figure 4)	
Air Motor Options 01 - Integrated On/Off Valve and Regulator	

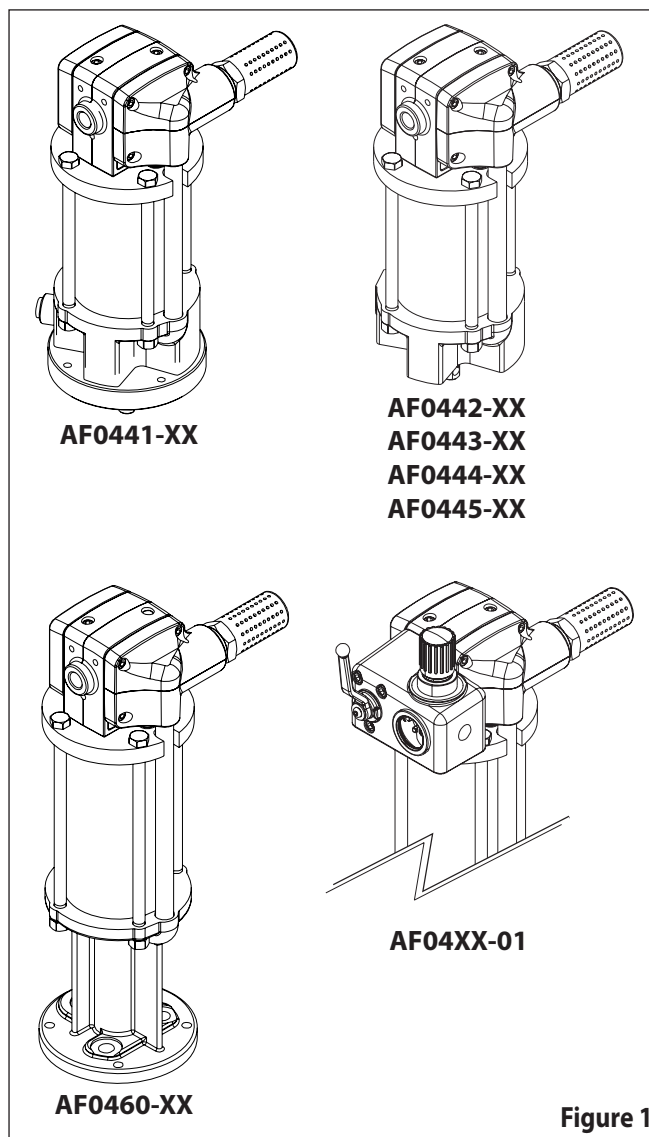

Figure 1

OPERATING AND SAFETY PRECAUTIONS

- **DO NOT EXCEED MAXIMUM AIR INLET PRESSURE OF 150 P.S.I. (10.3 BAR) OR 75 CYCLES PER MINUTE.**
- **⚠ CAUTION High pressure equipment – Always disconnect air supply and relieve material pressure before attempting to service.**
- A ground lug is located on the air motor. This ground lug allows proper grounding of the pump.

PARTS LIST / AF044X-XX & AF046X-XX

Item	Description	(Qty)	Part No.	[Mtl]
✓111	O-Ring (1/8" X 4 1/4" o.d.)	(2)	Y325-242	[B]
✓113	O-Ring (1/16" X 3/4" o.d.)	(4)	Y325-16	[B]
*115	Rod	(1)		[SS]
✓116	O-Ring (3/16" X 4 1/4" o.d.)	(1)	Y325-344	[B]
*117	Piston	(1)		[A]
*118	O-Ring (1/16" X 1 1/16" o.d.)	(1)		[B]
*119	Bushing	(1)		[C]
*120	Trip Rod Assembly	(1)		[A]
122	Head Plate	(1)	96859	[A]
✓123	O-Ring (3/32" X 1 1/2" o.d.)	(1)	Y325-109	[B]
✓124	O-Ring (1/16" X 2" o.d.)	(1)	Y325-32	[B]
125	Cap	(1)	96897	[D]
126	Sleeve	(1)	96901	[Br]
127	Ground Lug	(1)	96878	[Bz]
✓128	O-Ring (1/16" X 1 11/16" o.d.)	(1)	96917	[B]
129	Snap Ring (1.180" o.d.)	(1)	Y147-7	[C]
130	Washer	(1)	96894	[C]
131	Pin	(1)	96895	[C]
132	Driver	(1)	96868	[C]
✓133	U-Cup (3/16" X 1 1/2" o.d.)	(1)	96908	[B]
134	Spool	(1)	96875	[A]
135	Vent Bushing	(1)	96896	[D]
✓136	U-Cup (5/32" X 1 3/8" o.d.)	(1)	96907	[B]
137	Tube	(1)	96873	[C]
138	Socket Head Screw (5/16"-18 X 1")	(8)	Y99-52	[C]
140	Head Manifold	(1)	96854	[A]
✓141	Major Gasket	(1)	96900	[B]
142	Valve Plate	(1)	96884	[CK]
143	D-Valve	(1)	96889	[D]
144	Valve Housing	(1)	96864	[A]
145	Socket Head Screw (5/16"-18 X 4 1/2")	(2)	Y99-516	[C]
146	Pilot Insert	(1)	96882	[D]
147	Pilot Valve Plate	(1)	96883	[CK]
✓148	Pilot Gasket	(1)	96899	[B]
149	Vent Plug	(1)	96906	[D]
150	Pilot Cover	(1)	96865	[A]
155	Muffler	(1)	96916	[C]
201	Muffler Kit (Optional, See Fig. 5)	(1)	67445-1	[C]
202	Regulator / Shut-Off (Optional, See Fig. 5)	(1)	67442	
✓	Lubriplate FML-2 Grease Packet (1/4 oz.)	(2)	94276	

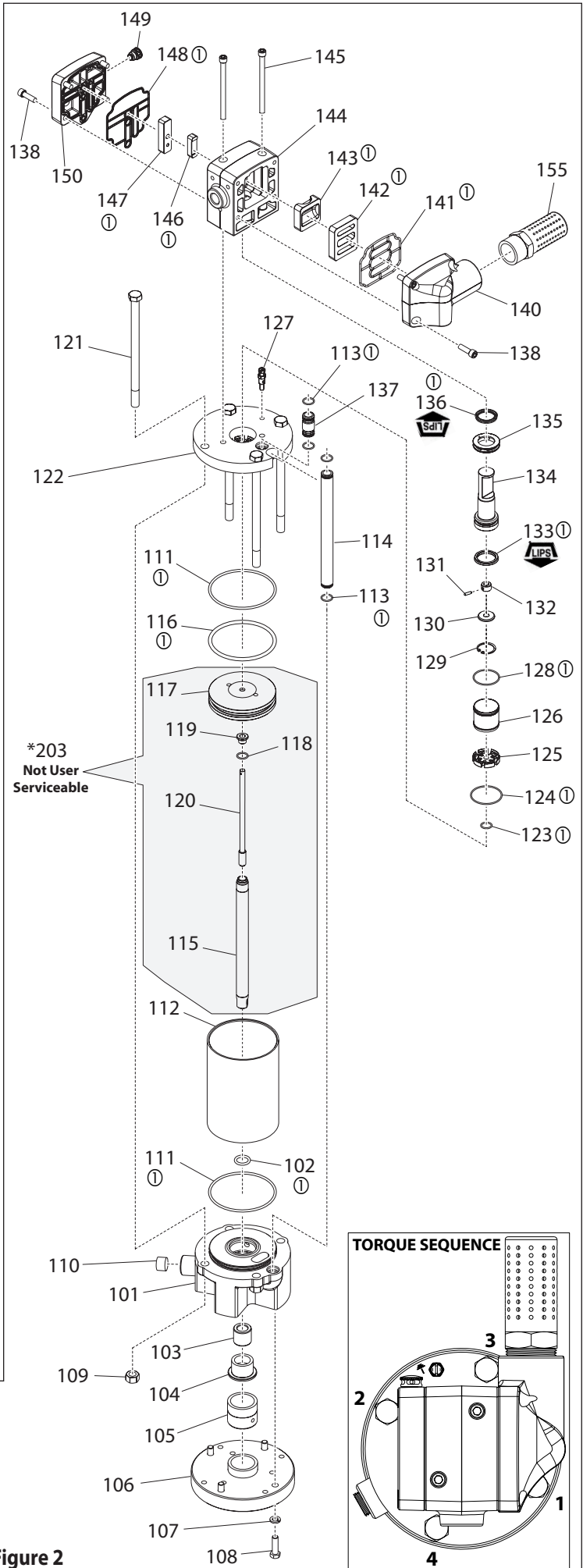

Figure 2

TORQUE REQUIREMENTS

NOTE: DO NOT OVERTIGHTEN FASTENERS.
 Tighten (109 & 121) to 10-15 ft-lbs (13.6-20.3 Nm)
 Tighten (138 & 145) to 50-60 in-lbs (5.6-6.8 Nm)

LUBRICATION / SEALANTS

① NOTE: Lubricate with Grease (ARO p/n 94276).

PARTS LIST / AF044X-XX & AF046X-XX

Item	Description (size)	Part No.	(Qty)	[Mtl]	AIR MOTOR MODEL NO.					
					AF0441-XX	AF0442-XX	AF0443-XX	AF0444-XX	AF0445-XX	AF0460-XX
101	Base & Bearing (Stub)**	65020	(1)	[A]						
	Base & Bearing	65023	(1)	[A]						
	Base & Bearing (Stub)	65775	(1)	[A]						
	Base (Stub)	90074	(1)	[A]						
✓102	O-Ring (1/8" x 1" O.D.)	Y325-210	(1)	[B]						
	O-Ring (1/8" x 1 5/8" O.D.)	Y325-220	(1)	[B]						
103	Bushing	93310	(1)	[D]						
104	Retainer	93311	(1)	[SS]						
105	Guide	93312	(1)	[SS]						
106	Plate	93958	(1)	[A]						
107	Lock Washer	Y14-616-C	(4)	[C]						
108	Screw	Y6-66-C	(4)	[C]						
109	Nut (1/2" - 20)	Y11-8-C	(4)	[C]						
110	Plug (1/2-14 N.P.T. X 9/16")	93897-1	(1)	[PP]						
112	Cylinder	96936	(1)	[Ef]						
		96935	(1)	[Ef]						
114	Tube	96874-1	(1)	[C]						
		96874-2	(1)	[C]						
121	Bolt (1/2" - 20 x 10 1/4")	94046-1	(4)	[C]						
		94046-2	(4)	[C]						
151	Washer	90103	(1)	[A]						
✓152	U-Cup (1/4" X 1 1/4" O.D.)	Y186-16	(1)	[B]						
153	Washer	73986	(1)	[Br]						
154	Snap Ring (1.456" O.D.)	Y147-131	(1)	[C]						
*203	Piston Assembly (includes items 115, 117, 118, 119, & 120)	67489	(1)	--						
		67490	(1)	--						
		67491	(1)	--						
		67492	(1)	--						
		67493	(1)	--						
		67494	(1)	--						

■ Indicates where parts are used.

✓ Items included in Service Kit (637489).

NOTE: Base styles and lower packings may vary from that shown on the cover. Refer to model number in the chart above.

For simplification of ordering and stocking, the Universal Service Kit contains service parts that can be used for every size of air motor. When repairing the motor, use only the parts that are needed for that specific motor. Extra service parts from the kit will remain after repair of the air motor.

MATERIAL CODE

[A] = Aluminum	[D] = Acetal
[B] = Buna Nitrile	[PP] = Polypropylene
[Br] = Brass	[SS] = Stainless Steel
[Bz] = Bronze	[Ef] = Epoxy - Fiberglass Filament Reinforced
[C] = Carbon Steel	
[CK] = Ceramic	

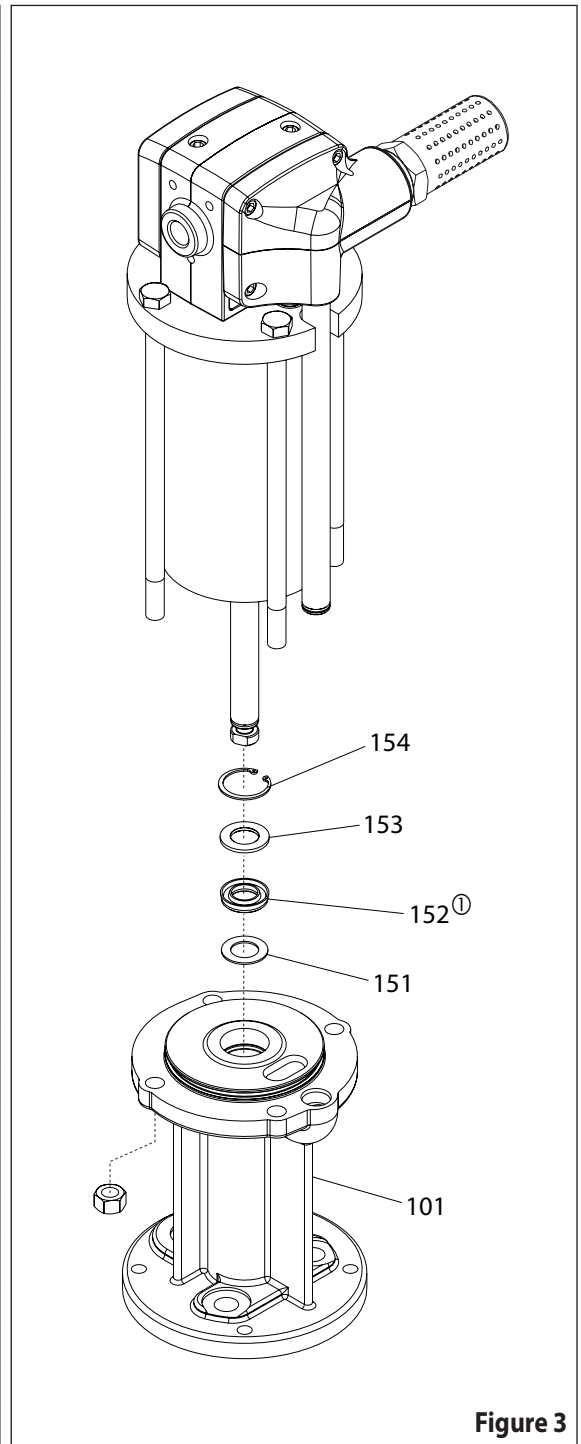

Figure 3

DISASSEMBLY OF AIR MOTOR

NOTE: All threads are right hand.

1. Force the piston assembly up by pushing the (115) rod toward the top of the air motor.
2. Remove the (155) muffer/(201) muffer assembly for ease of disassembly.
3. Remove four (138) socket head screws from the (140) head manifold. Remove the (140) head manifold by pulling up and outward to remove from tubes (114) and (137).
4. Remove (141) major gasket from the (140) head manifold.
5. Remove tubes (114) and (137) by pulling upward.
6. Remove the four (113) O-rings from both tubes (114) and (137).

(continued on page 4)

DISASSEMBLY OF AIR MOTOR (CONT'D)

7. Remove the (142) valve plate and the (143) D-valve from the (144) valve housing.
8. Remove the four (138) socket head screws to extract the (150) pilot cover.
9. Remove the (148) pilot gasket from the (150) pilot cover.
10. Remove the (147) pilot valve plate and the (146) pilot insert from the (144) valve housing.
11. Remove the two (145) socket head screws from the (144) valve housing.
12. Remove the (144) valve housing by pulling straight up.
13. Remove the (124) O-ring, the (135) vent bushing, and the (136) U-cup from the (144) valve housing.
14. Remove the (128) O-ring and the (126) sleeve from the motor assembly by sliding it straight up.
15. Pull the (134) spool as far from the motor assembly as possible to expose the under side of the spool itself.
16. Locate and remove the (129) snap ring from the (134) spool utilizing snap ring pliers.
17. Lift to remove the (134) spool and remove the (133) U-cup from it.
18. Slide the (131) pin to remove the (132) driver, (130) washer, and (129) snap ring from the (120) trip rod assembly.
19. Remove the four (109) nuts from (121) hex head bolts.
20. Remove the four (121) bolts from the (122) head plate and the (101) base assembly.
21. Remove (122) head plate from the (112) air cylinder.
22. Remove the (111) O-ring, the (125) cap, and (123) O-ring from the (122) head plate.
23. Pull upward on (112) air cylinder until (203) piston assembly separates from the (101) base assembly. If, in this step, the (203) piston assembly is not pulled from the (101) base assembly, then remove it after removing the (112) air cylinder.
24. If the (112) air cylinder and (203) piston assembly are removed as one unit, then remove the (203) piston assembly from the (112) air cylinder.
25. Remove the (116) O-ring from the (117) piston.
26. Remove the (111) O-ring from (101) base assembly.
27. For model AF0460-XX, remove (154) snap ring, (153) washer, (152) U-cup, and (151) washer from the (101) base assembly. For all other models remove the (102) O-ring from the (101) base assembly.

REASSEMBLY OF AIR MOTOR

1. Apply grease to all O-rings, U-cups, and other rubber goods before installing.
2. For model AF0460-XX, install (151) washer, (152) U-cup, (153) washer, and (154) snap ring into the (101) base assembly. For all other models, install the (102) O-ring into the (101) base assembly.
3. Install the (111) O-ring in the groove on the (101) base assembly.
4. Install the (116) O-ring in the groove on the (117) piston.
5. Push (115) piston rod thru the (101) base assembly, being careful not to damage the lips of the (152) U-cup or the (102) O-ring.
6. Lubricate the inside diameter of the (112) air cylinder and slide it down over the (203) piston assembly and onto the (101) air motor base assembly. (See Figure 2 on page 2).

7. Align notch in (122) head plate with the port in (101) base assembly and press the (122) head plate down until it is seated against the (112) air cylinder. The (120) trip rod assembly must lead thru the center of the (122) head plate.
8. Assemble the four (121) bolts thru the (122) head plate and the (101) base assembly.
9. Assemble the four (109) nuts to (121) hex head bolts and tighten per specified torque sequence and value.
10. Pull the (120) trip rod assembly as far out of the air motor assembly as possible, slide the (123) O-ring over the (120) trip rod assembly and down into the gland found in the (122) head plate.
11. Slide the (125) cap over the (120) trip rod assembly and down into the bore found in the (122) head plate.
12. Slide the (129) snap ring first and the (130) washer secondly, onto the (120) trip rod assembly.
13. Slide the (132) driver onto the (120) trip rod assembly. Align the hole of the (132) driver with the hole in the (120) trip rod assembly and insert the (131) pin.
14. Assemble the (133) U-cup to the (134) spool. Take note of the (133) U-cup lips should point down towards the (122) head plate.
15. Slide the (134) spool onto the (120) trip rod assembly over the (132) driver and insert the (130) washer behind it. Utilizing snap ring pliers, assemble the (129) snap ring to the internal groove found in the (134) spool. Be certain that the (129) snap ring is fully engaged into the groove. Slide the (134) spool downward into the bore of the (122) head plate nesting on top of the (125) cap.
16. Lubricate the inside diameter of the (126) sleeve and slide it onto the (134) spool and locating it into the (125) cap. Take note that large taper on (126) Sleeve is to locate into (125) Cap.
17. Install the (128) O-ring onto the top gland of the (126) sleeve.
18. Install the (136) U-cup, the (135) vent bushing into the center bottom bore of the (144) valve housing. Take note that the (136) U-cup lips must be facing up towards the top of the (144) valve housing. Install the (124) O-ring into the bottom recess gland of the (144) valve housing.
19. Install the (144) valve housing to the motor assembly by sliding the center bore onto the (134) spool and the (126) sleeve. Take caution not to dislodge any of the O-rings (124 & 128). Take note to align the large valve pocket on the side of the (144) valve housing towards the notch in the (122) head plate.
20. Install the two (145) socket head screws thru the (144) valve housing and thread into the (122) head plate. The (144) valve housing may need to be rotated slightly to align the tapped holes. Tighten the (145) socket head screws per specified torque value.
21. Install the (146) pilot insert, with pocket facing outward, thru the (144) valve housing and into the (134) spool. The (134) spool may need to be turned to orient its' shallower slot to face the smaller pocket of the (144) valve housing.
22. Install the (147) pilot valve plate, with identification dimple facing outward, into the (144) valve housing covering the (146) pilot insert.
23. Install the (148) pilot gasket into the (150) pilot cover and assemble to the (144) valve block using four (138) socket head screws. Tighten to torque specifications.
24. Install the (143) D-valve, with pocket facing outward, thru the (144) valve housing and into the (134) spool.

(continued on page 5)

REASSEMBLY OF AIR MOTOR (CONT'D)

25. Install the (142) major valve plate, with identification dimple facing outward, into the (144) valve housing covering the (143) D-valve.
26. Install the four (113) O-rings onto both (114 & 137) tubes.
27. Loosely install the (137) tube into the bore in the (122) head plate.
28. Loosely install the (114) tube into the bore in the (101) base assembly.
29. Install the (141) manifold gasket into the (140) manifold and telescope onto both (114 & 137) tubes until the (113) O-rings are seated. Fasten the (140) manifold to the (144) valve block using four (138) socket head screws. Tighten to torque specifications.
30. Install the (155) muffler/(201) muffler assembly.

TROUBLE SHOOTING

Air leakage out of main exhaust.

- Damaged (141) track gasket. Replace (141) track gasket.
- Worn (116) piston seal. Replace (116) piston seal.

Continual air leakage out (149) pilot exhaust.

- Worn (136) "U" cup. Damaged (148) track gasket. Replace (136) "U" cup and (148) track gasket.

Air leakage out (149) pilot exhaust only during the down stroke.

- Worn (133) "U" cup. Rolled or damaged (128) "O" ring. Replace (133) "U" cup and (128) "O" ring.

Air leakage around (115) piston rod.

- Worn or damaged (102) "O" ring or (152) "U" cup depending on motor model. Replace (102) "O" ring or (152) "U" cup depending on motor model.

VARIETIES OF BASE (101) AND PISTON ROD END (115)

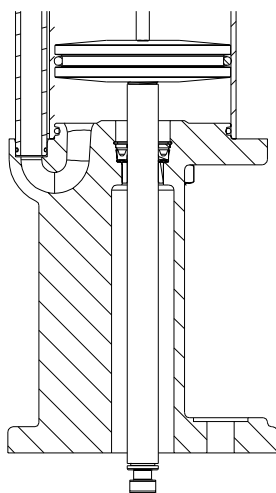

TYPE -0-

Divorced Base, Quick Coupled Rod
65023 BASE and
67489 PISTON ASSEMBLY

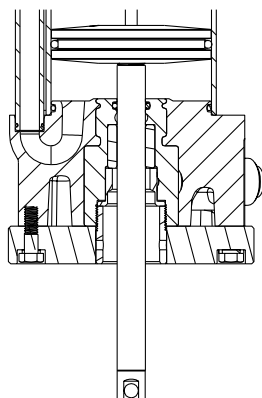

TYPE -1-

Divorced Base, Pin Coupled Rod
65020 BASE with 93958 INSERT and
67494 PISTON ASSEMBLY

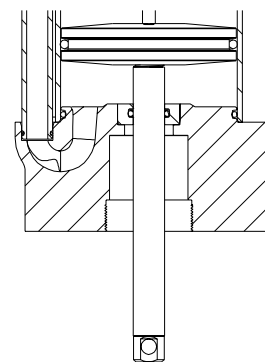

TYPE -2-

Coupled Base, Pin Coupled Rod
65775 BASE and
67493 PISTON ASSEMBLY

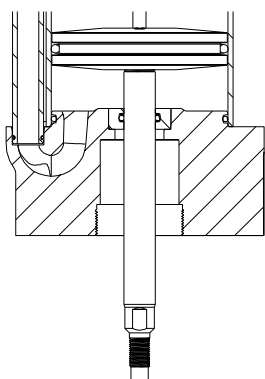

TYPE -3-

Coupled Base, Male Threaded Rod
65775 BASE and
67490 PISTON ASSEMBLY

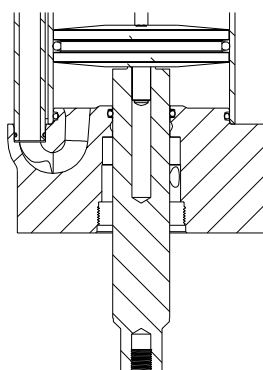

TYPE -4-

Coupled Base, Female Threaded Rod
90074 BASE and
67492 PISTON ASSEMBLY

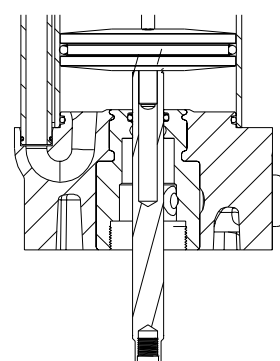

TYPE -5-

Coupled High Pressure Base,
Female Threaded Rod
65020 BASE and
67491 PISTON ASSEMBLY

Air Motor Base and Rod Combination

- 0 – Divorced pump base with quick coupled rod connection
- 1 – Divorced pump base with pin coupled rod connection
- 2 – Coupled pump base with pin coupled rod connection
- 3 – Coupled pump base with male threaded rod connection
- 4 – Coupled pump base with female threaded rod connection
- 5 – Coupled high pressure pump base with female threaded rod connection

Figure 4

Available Options for AF04XX-XX Air Motors

202
Optional
67442
Self-Relieving
Ball Valve
Regulator / Shut-Off
(AF04XX-01)

201
Optional
67445-1
Muffler Kit

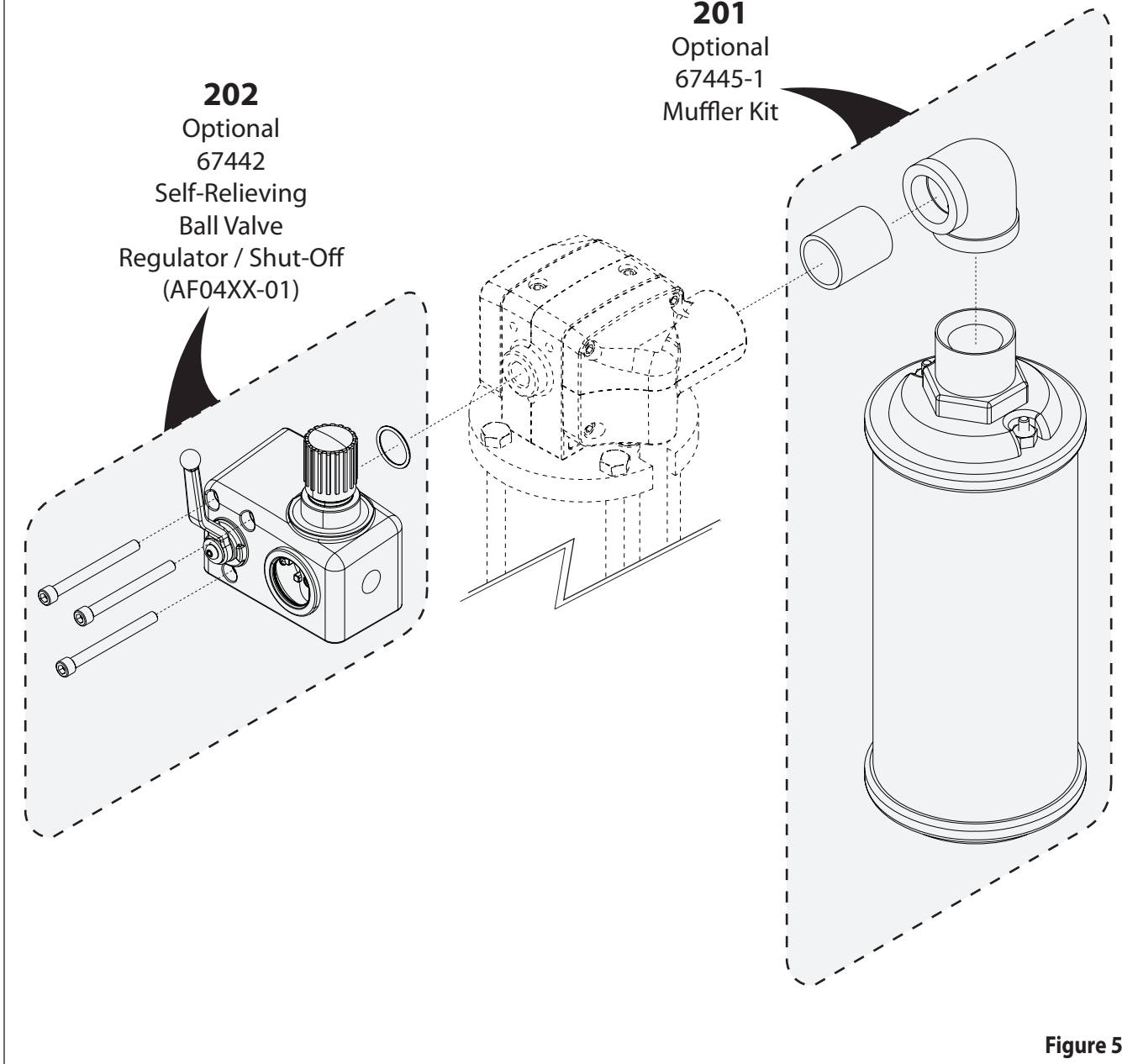

Figure 5

NOTES

ARO

IR *Ingersoll Rand*
Industrial Technologies

PN 97999-1466