

PARTS MANUAL

Model

**EH650VC0120
ENGINES**

PUB-EP7114
Rev. 10/10



Industrial Power Products

Robin America, Inc.

905 Telser Road • Lake Zurich, IL 60047 • Phone: 847-540-7300 • Fax: 847-438-5012
e-mail: sales@robinamerica.com • www.subarupower.com

© Copyright 2010 Robin America, Inc.

CONTENTS

	FIG.
1 CRANK CASE GROUP	102
2 CRANK,PISTON GROUP	202
3 INTAKE,EXHAUST GROUP	302
4 GOVERNOR GROUP	402
5 COOLING,STARTING GROUP	502
6 FUEL LUBRICANT GROUP	602, 644
7 FUEL LUBRICANT GROUP	702, 731

FIG. 102

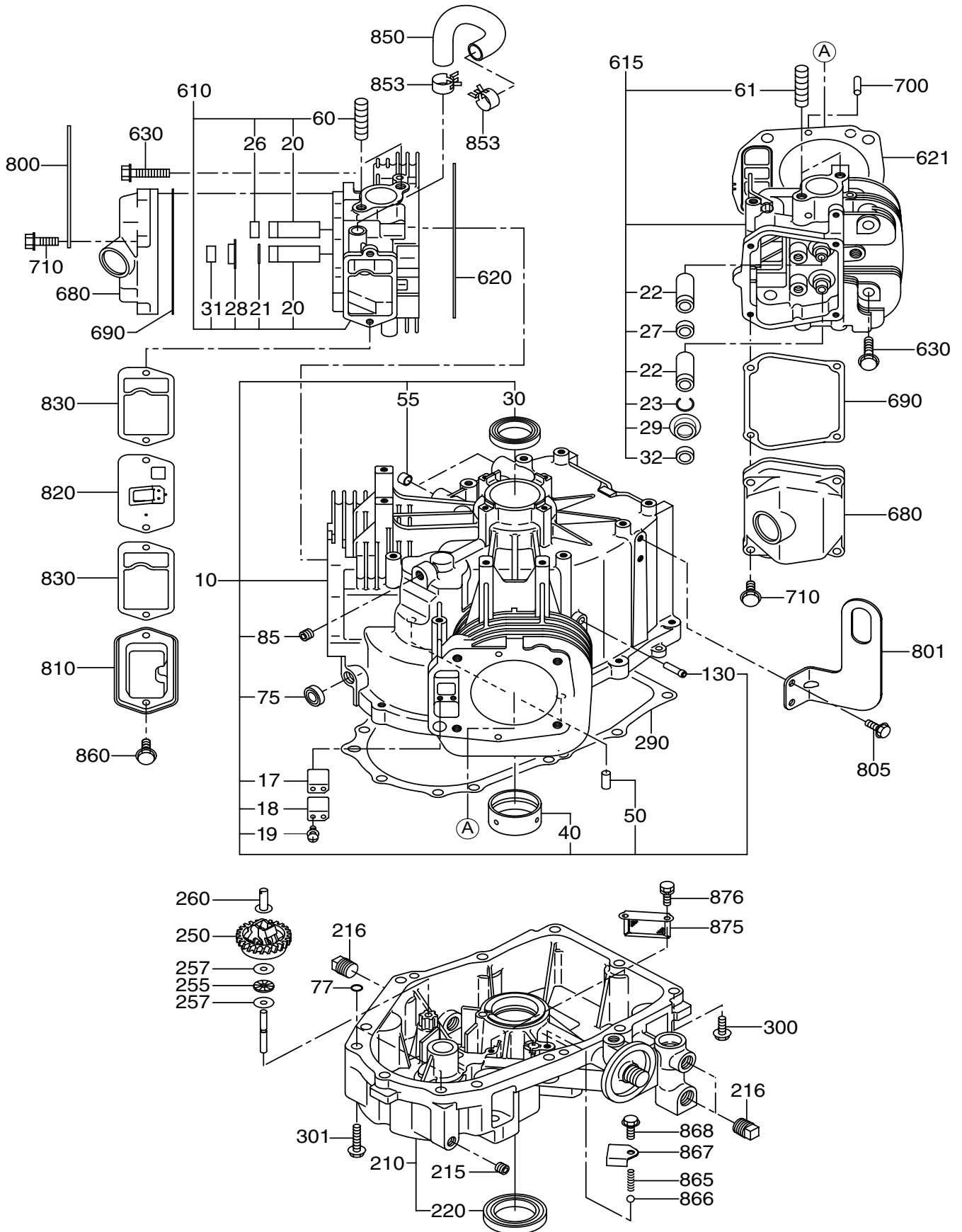

1 CRANK CASE GROUP

REF.	PART NUMBER	PART NAME	QTY	R E M A R K S	CODE NO.	INTERCHANGE P/NO.	UNIT P	FIG.
10	263-10201-D1	CRANK CASE CP	1		-			102
17	263-17101-B3	LEAF VALVE	2		-			102
18	263-17201-A3	RETAINER PLATE	2		-			102
19	004-35041-00	SCREW AND WASHER AY	4		-			102
20	263-14211-03	VALVE GUIDE	2	6DX11DX32. 5L	-			102
21	056-51000-50	CLIP	1	10. 7DX0. 9D	-			102
22	263-14211-03	VALVE GUIDE	2	6DX11DX32. 5L	-			102
23	056-51000-50	CLIP	1	10. 7DX0. 9D	-			102
26	132-11AA1-10	SEAL-EXH VALVE	1		-			102
27	132-11AA1-10	SEAL-EXH VALVE	1		-			102
28	263-35341-03	RETAINER PLATE	1	11DX17. 3DX27DX4. 7H	-			102
29	263-35341-03	RETAINER PLATE	1	11DX17. 3DX27DX4. 7H	-			102
30	044-03501-70	OIL SEAL	1	35DX48DX8B	-			102
31	263-39001-01	OIL SEAL (EX VALVE)	1		-			102
32	263-39001-01	OIL SEAL (EX VALVE)	1		-			102
40	263-15805-03	MAIN BEARING	1		-			102
50	X31-00800-80	DOWEL PIN	2	8DX18L	-			102
55	263-55601-03	PIPE	2	11DX8. 8DX8L	-			102
60	010-50802-90	STUD	4	M8X1. 25X30L	-			102
61	010-50802-90	STUD	4	M8X1. 25X30L	-			102
75	044-00800-10	OIL SEAL	1	8DX14DX4B	-			102
77	024-00090-00	O RING	2		-			102
85	263-15911-A1	BLIND PLUG CP	1	PT1/8X9L	-			102
130	159-65401-03	PIPE (PULSE)	1	4DX6DX25L	-			102
210	263-11021-A1	MAIN BEARING COVER	1		-			102
215	263-15911-A1	BLIND PLUG CP	1	PT1/8X9L	-			102
216	263-17404-A3	PLUG	3		-			102
220	044-04200-30	OIL SEAL	1	42DX60DX9B	-			102
250	263-45101-C1	GOVERNOR GEAR CP	1		-			102
255	263-46215-A3	THRUST BEARING	1		-			102
257	263-46214-A3	WASHER	2		-			102
260	277-41902-01	GOVERNOR SLEEVE CP	1		-			102
290	263-16011-A3	GASKET, M, B, COVER	1		-			102
300	X11-00800-90	FLANGE BOLT	7		-			102
301	001-04087-50	FLANGE BOLT EC35PL	3	M8X1. 25X16DX75L	-			102
610	263-13201-B1	CYLINDER HEAD 1CP	1		-			102
615	263-13301-B1	CYLINDER HEAD 2CP	1		-			102
620	263-15021-31	GASKET 1 (CYL HEAD)	1		-			102
621	263-15121-21	GASKET 2 (CYL HEAD)	1		-			102
630	X11-01000-70	FLANGE BOLT	8	M10X1. 25X19DX65L	-			102

FIG. 102

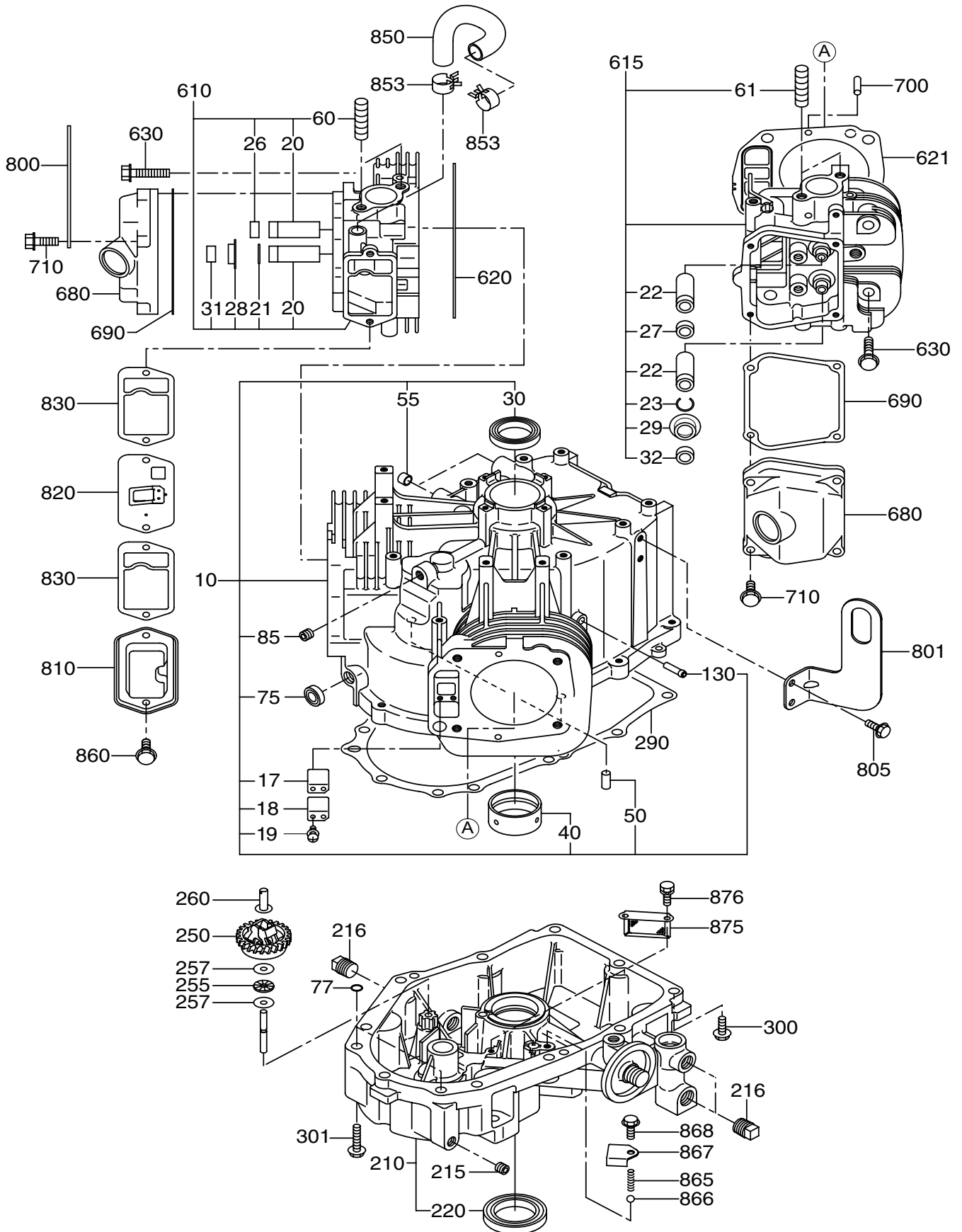

FIG. 202

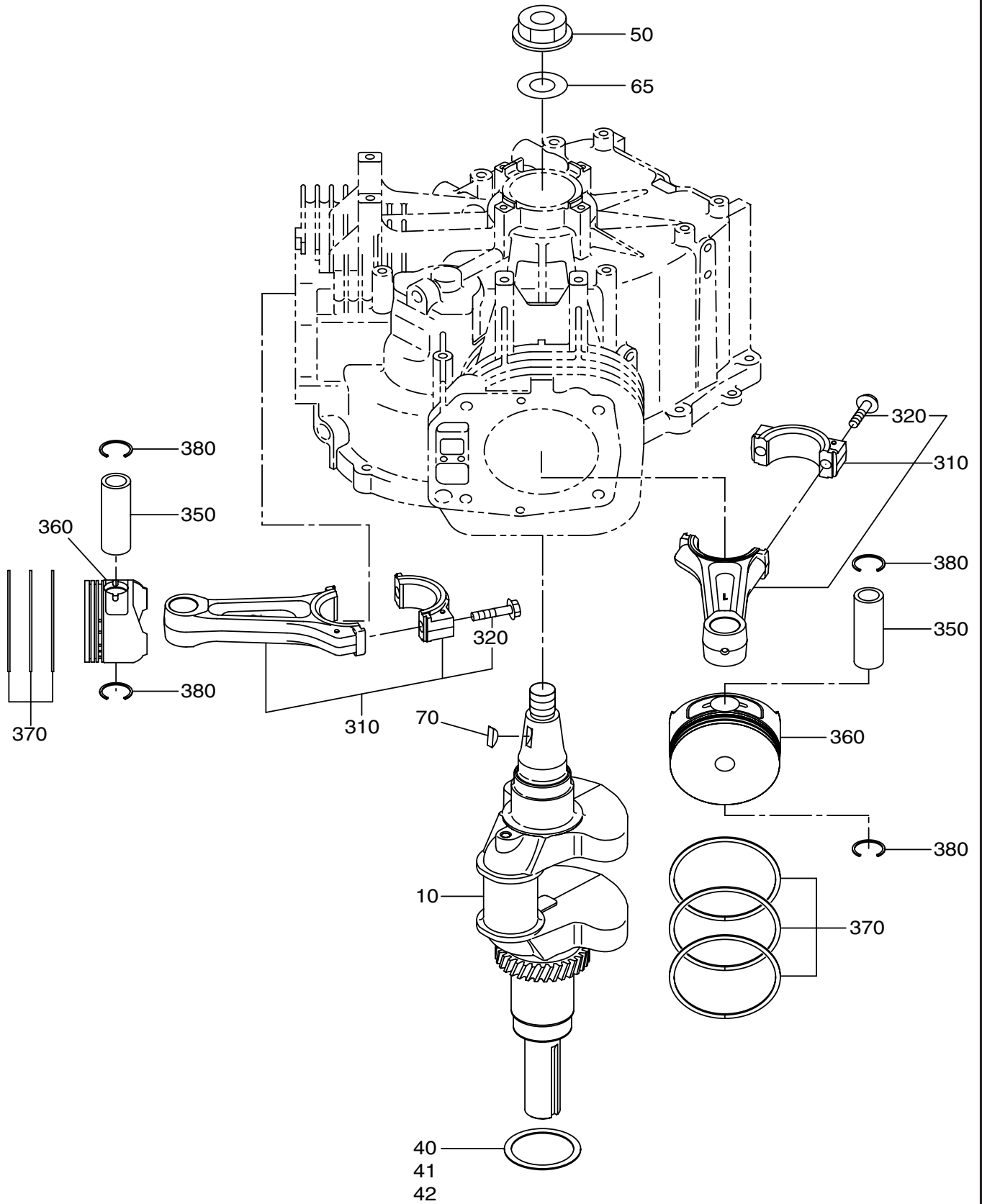

FIG. 302

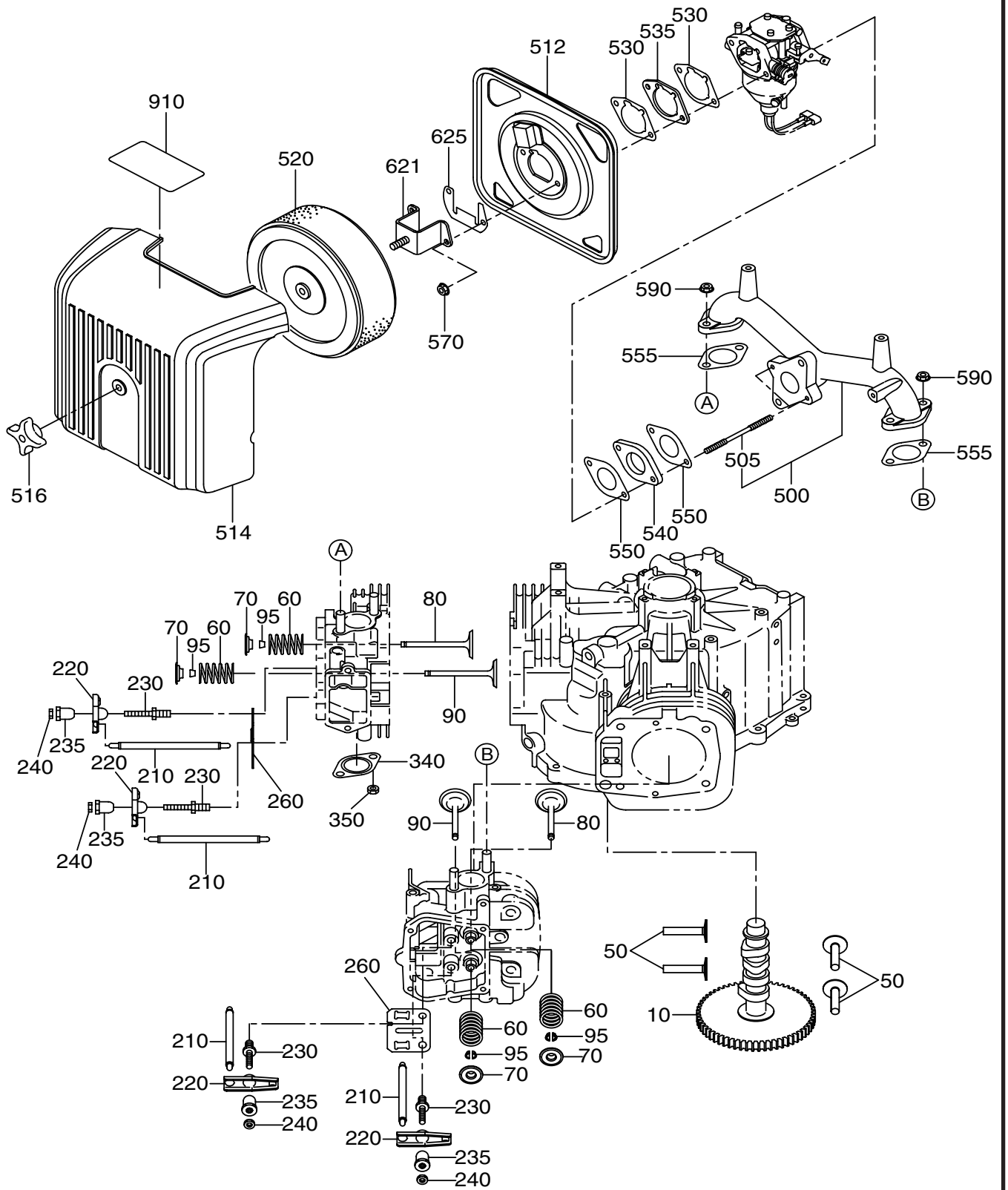

FIG. 402

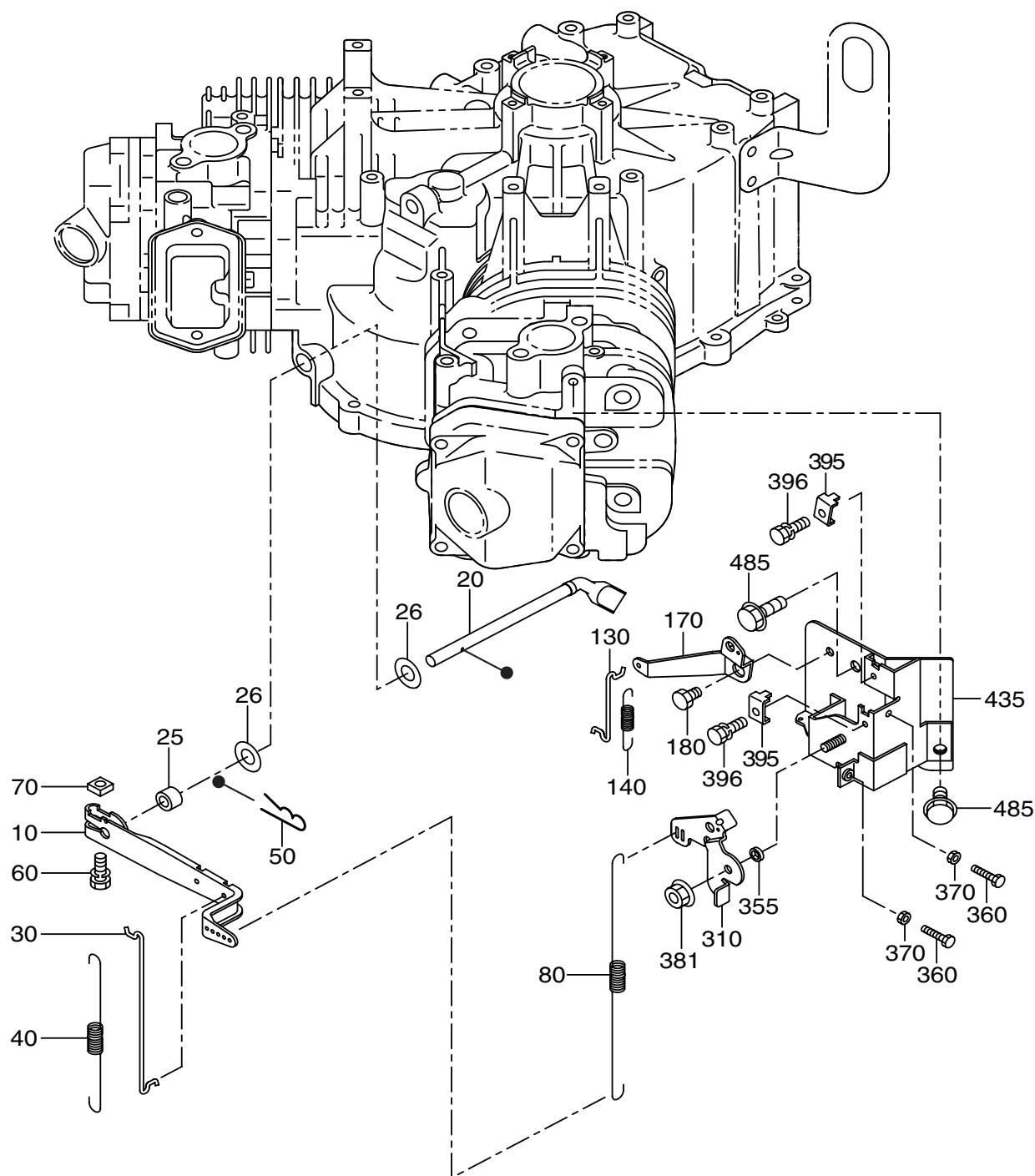

FIG. 502

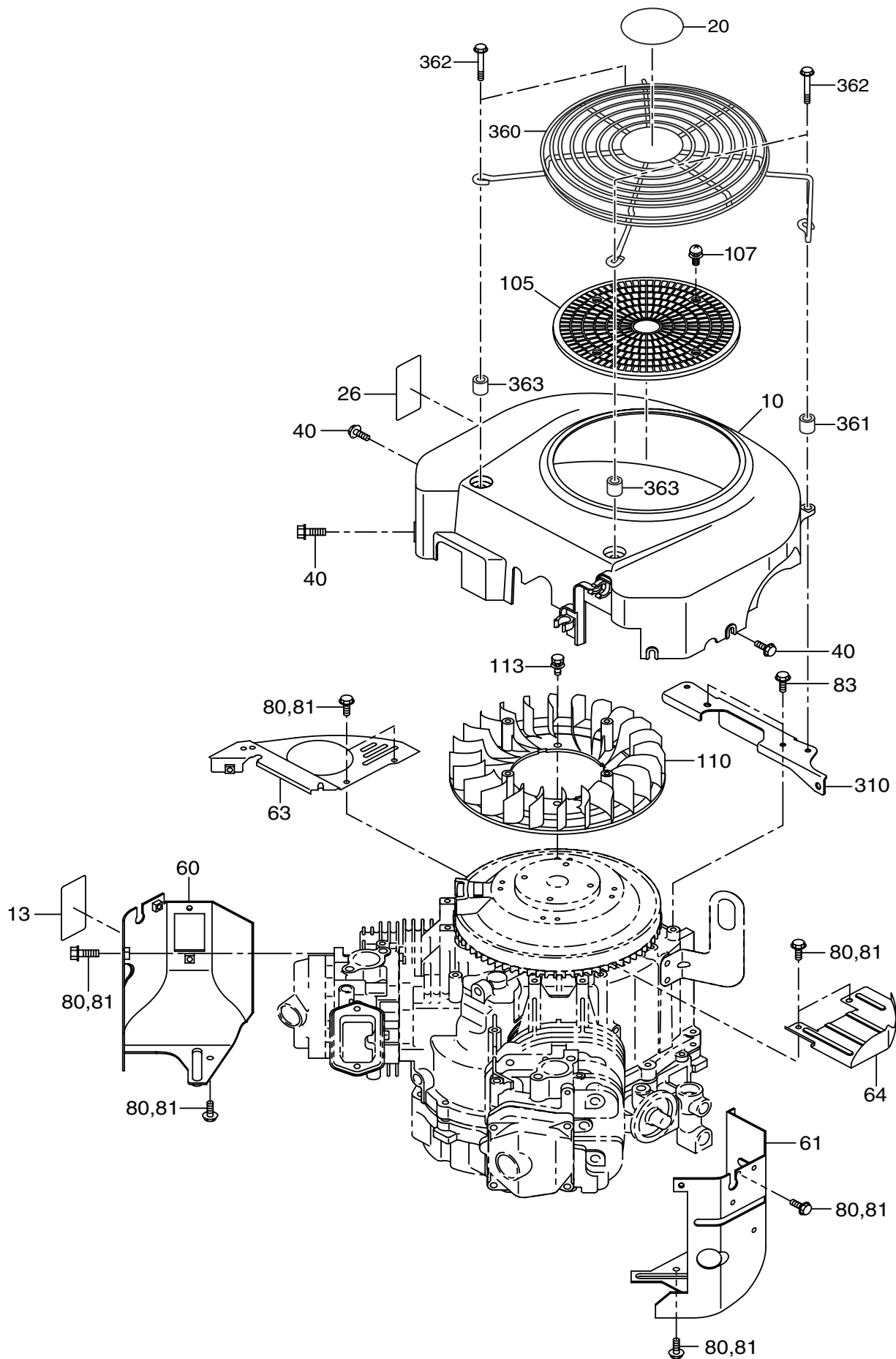

FIG. 602

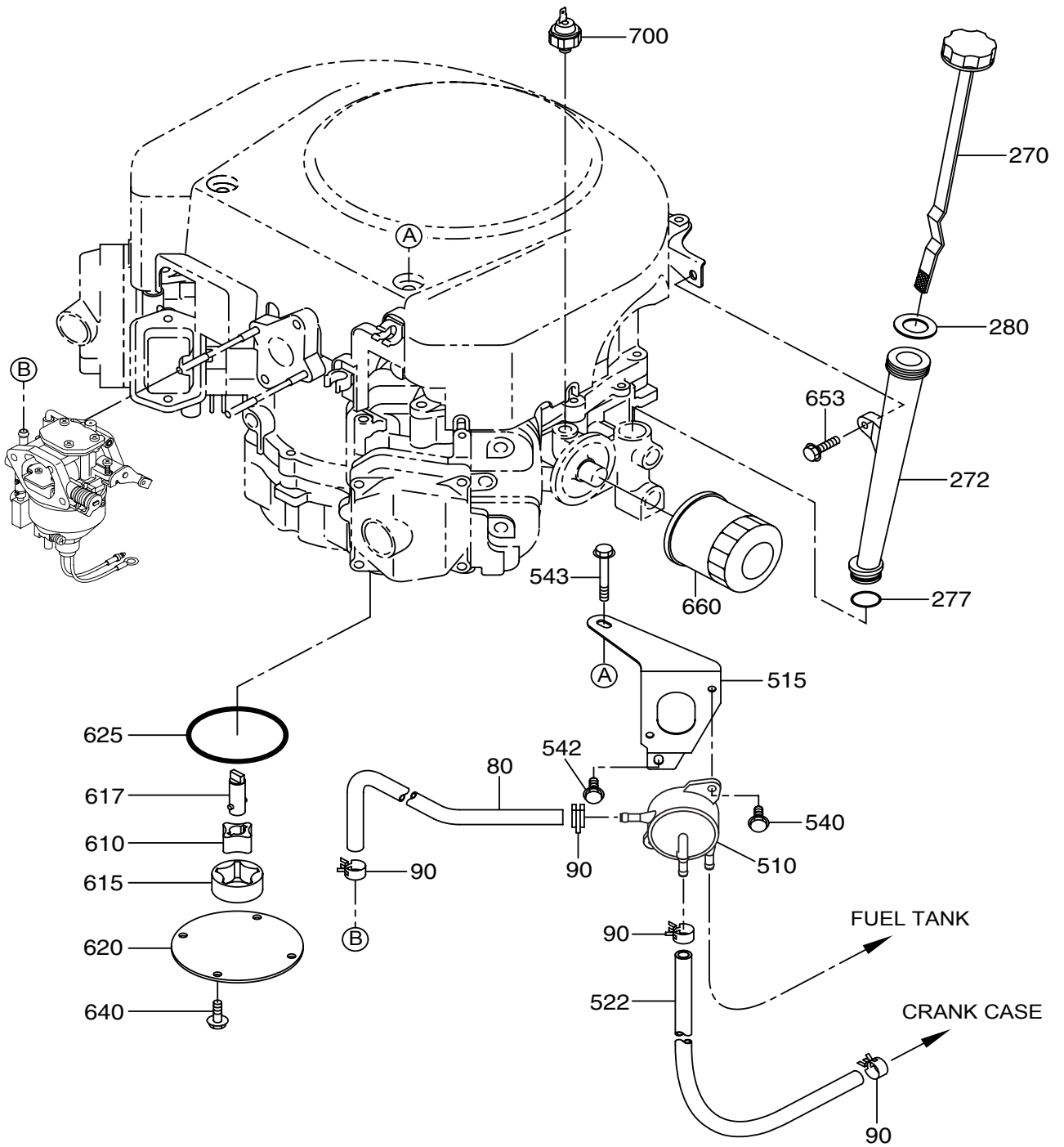
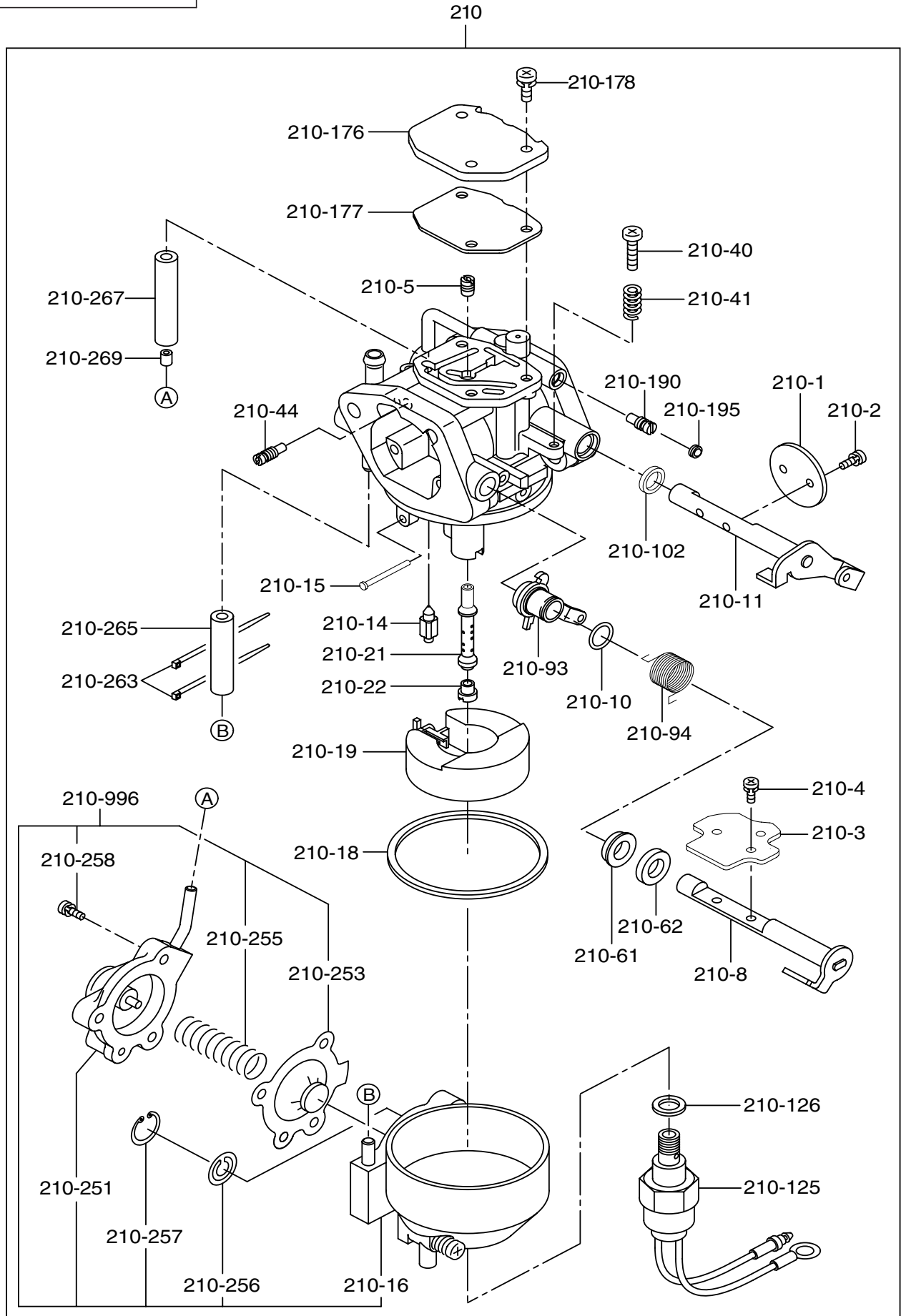

FIG. 644



6 FUEL LUBRICANT GROUP

REF.	PART NUMBER	PART NAME	QTY	R E M A R K S	CODE NO.	INTERCHANGE P/NO.	UNIT P	FIG.
210	263-62371-10	CARBURETOR AY	1		-			644
- 1	263-62536-08	VALVE, THROTTLE	1		-			644
- 2	258-62555-08	SCREW SET (VALVE)	2		-			644
- 3	263-62525-08	VALVE, CHOKE	1		-			644
- 4	261-62352-08	SCREW, VALVE SET	2		-			644
- 5	263-62422-08	JET ASSY, SLOW	1		-			644
- 8	263-62521-08	SHAFT ASSY, CHOKE	1		-			644
- 10	258-62551-08	RING (CHOKE LEVER)	1		-			644
- 11	263-62533-08	SHAFT ASSY, THROTTLE	1		-			644
- 14	226-62501-08	VALVE, FLOAT	1		-			644
- 15	263-62515-08	PIN, FLOAT	1		-			644
- 16	263-62582-08	CHAMBER AY, FLOAT	1		-			644
- 18	263-62575-08	GASKET, FLOAT CHAMBER	1		-			644
- 19	263-62505-08	FLOAT	1		-			644
- 21	263-62440-08	NOZZLE, MAIN	1		-			644
- 22	263-62404-08	JET, MAIN	1		-			644
- 40	263-62586-08	SCREW, ROUND MACHINE	1		-			644
- 41	226-62446-08	SPRING, THRO. AD. SCREW	1		-			644
- 44	263-62410-08	JET, AIR BLEED	1		-			644
- 61	280-62551-08	COLLAR, CHOKE	1		-			644
- 62	258-62554-08	FILTER (CHOKE SHAFT)	1		-			644
- 93	263-62522-08	LEVER ASSY, CHOKE	1		-			644
- 94	263-62445-08	SPRING, CHOKE	1		-			644
-102	263-62590-08	FILTER AIR	1		-			644
-125	263-62558-08	VALVE ASSY, SOLENOID	1		-			644
-126	215-62430-08	GASKET, MAIN JET	1		-			644
-176	263-62545-08	GASKET, PASSAGE COVER	1		-			644
-177	263-62565-08	COVER, PASSAGE	1		-			644
-178	263-62585-08	SCREW, WITH WASHER	3		-			644
-190	261-62435-08	NEEDLE (IDLE ADJUST)	1		-			644
-195	261-62358-08	PLUG, EXPANSION	1		-			644
-251	263-62361-08	COVER AY, DIAPHRAGM	1		-			644
-253	263-62358-08	DIAPHRAGM AY	1		-			644
-255	263-62320-08	SPRING, ACC DIAPHRAGM	1		-			644
-256	263-62354-08	VALVE, CHECK	1		-			644
-257	263-62355-08	RING "C"	1		-			644
-258	263-62587-08	SCREW, COVERSET	3		-			644
-263	107-62381-08	BAND, NYLON	2		-			644
-265	263-62357-08	HOSE, FUEL	1		-			644
-267	263-62356-08	HOSE, VACCUM	1		-			644

FIG. 644

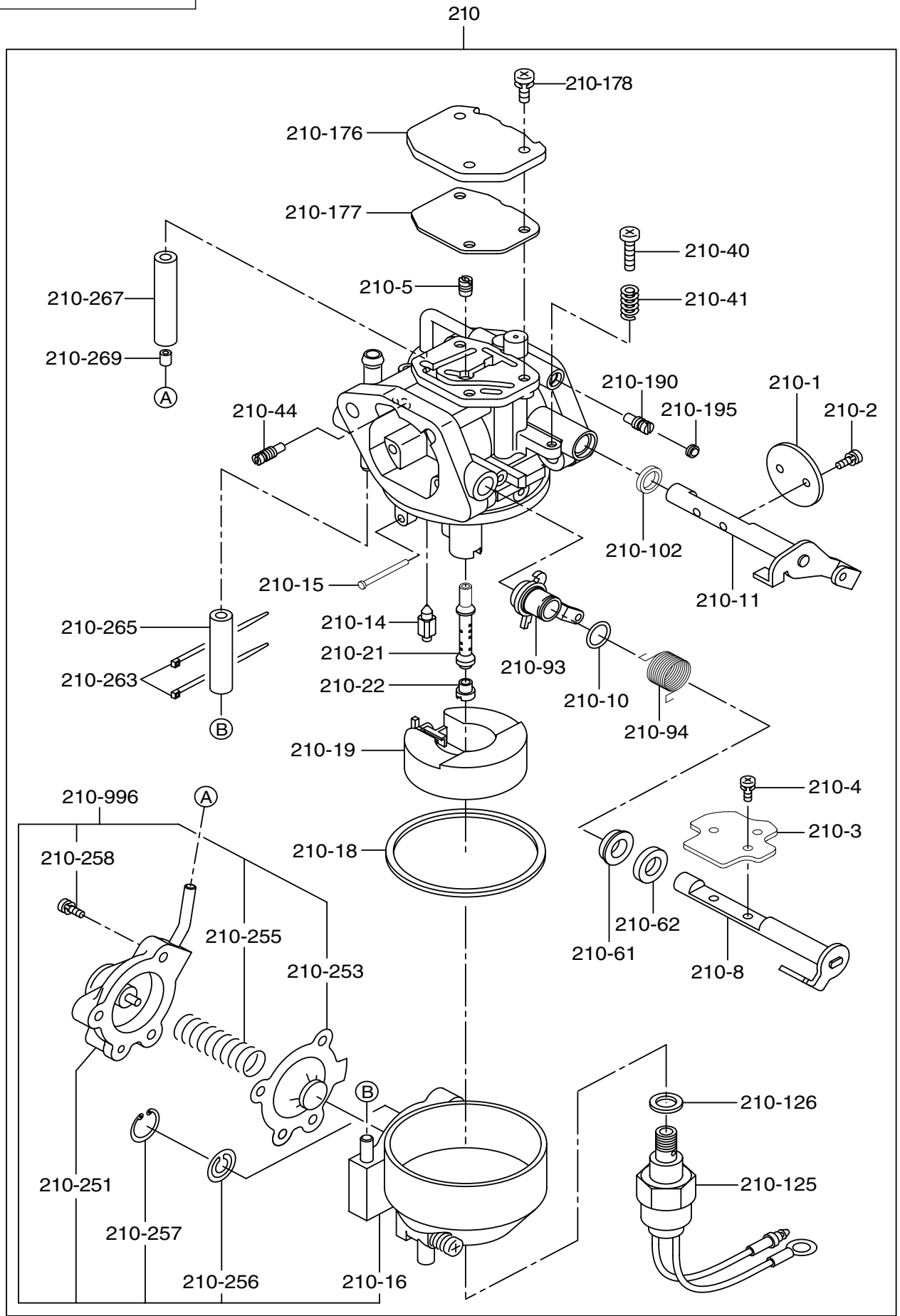
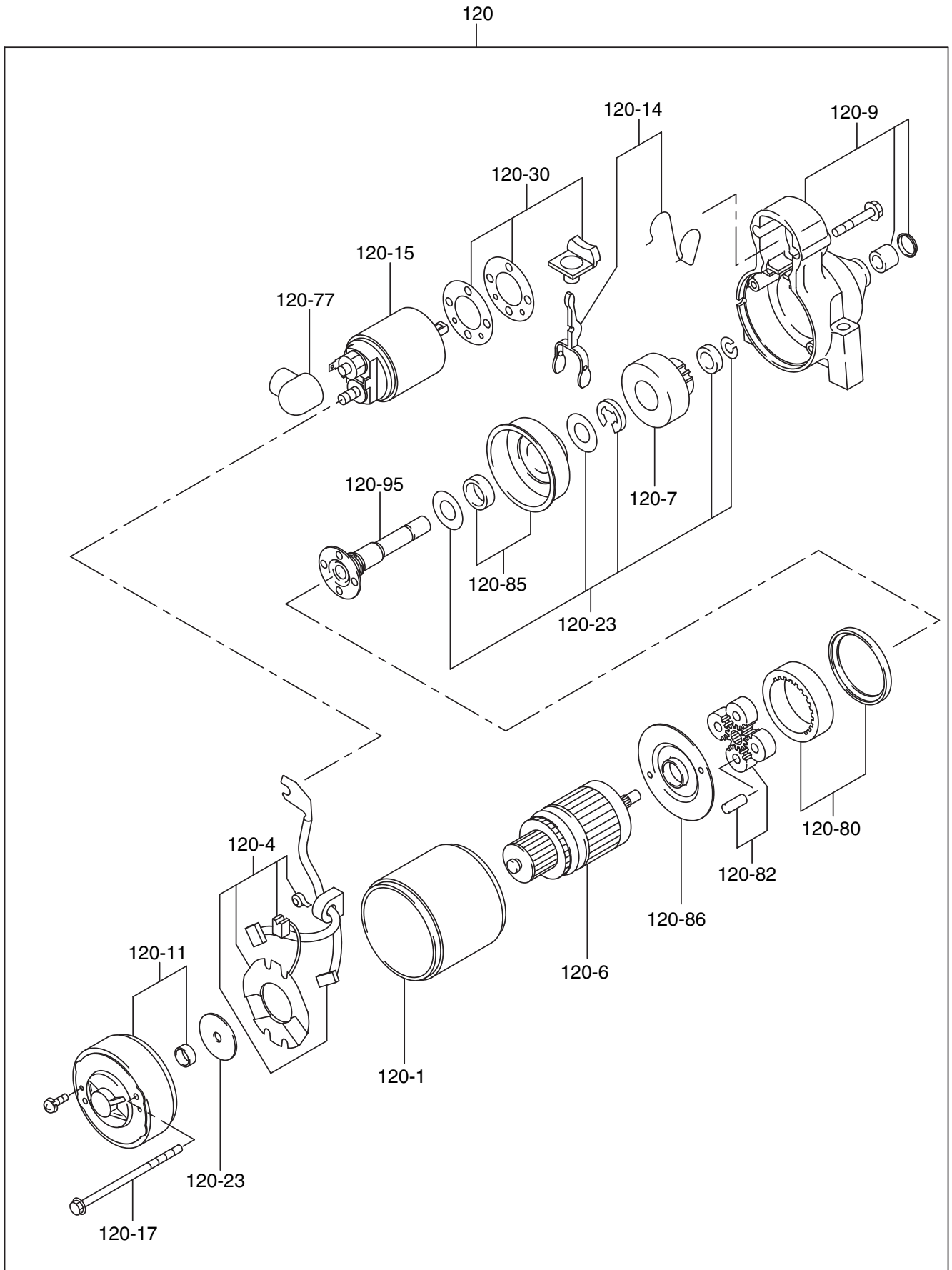

FIG. 731



PRINTED IN THE USA

Robin America, Inc

905 Telsler Road • Lake Zurich, IL 60047
Phone: 847-540-7300 • Fax: 847-438-5012
e-mail: sales@subarupower.com • www.subarupower.com