

C·que 8

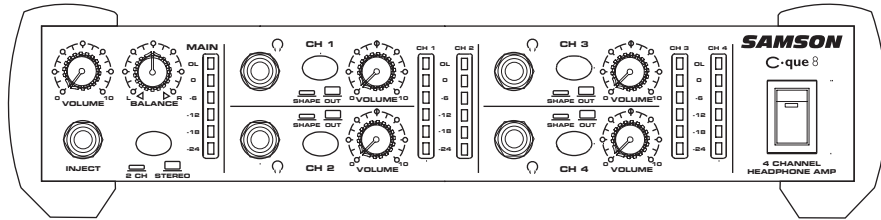

4 CHANNEL HEADPHONE AMP

Owners Manual

Safety Instructions

Caution: To reduce the hazard of electrical shock, do not remove cover or back.

No user serviceable parts inside. Please refer all servicing to qualified personnel.



WARNING: To reduce the risk of fire or electric shock, do not expose this unit to rain or moisture.

The lightning flash with an arrowhead symbol within an equilateral triangle, is intended to alert the user to the presence of uninsulated "dangerous voltage" within the products enclosure that may be of sufficient magnitude to constitute a risk of electric shock to persons.

The exclamation point within an equilateral triangle is intended to alert the user to the presence of important operating and maintenance (servicing) instructions in the literature accompanying the product..

Important Safety Instructions

1. Please read all instructions before operating the unit.
2. Keep these instructions for future reference.
3. Please heed all safety warnings.
4. Follow manufacturers instructions.
5. Do not use this unit near water or moisture.
6. Clean only with a damp cloth.
7. Do not block any of the ventilation openings. Install in accordance with the manufacturers instructions.
8. Do not install near any heat sources such as radiators, heat registers, stoves, or other apparatus (including amplifiers) that produce heat.
9. Do not defeat the safety purpose of the polarized or grounding-type plug. A polarized plug has two blades with one wider than the other. A grounding type plug has two blades and a third grounding prong. The wide blade or third prong is provided for your safety. When the provided plug does not fit your outlet, consult an electrician for replacement of the obsolete outlet.
10. Protect the power cord from being walked on and pinched particularly at plugs, convenience receptacles and at the point at which they exit from the unit.
11. Unplug this unit during lightning storms or when unused for long periods of time.
12. Refer all servicing to qualified personnel. Servicing is required when the unit has been damaged in any way, such as power supply cord or plug damage, or if liquid has been spilled or objects have fallen into the unit, the unit has been exposed to rain or moisture, does not operate normally, or has been dropped.

Table of Contents

| | |
|--|-----|
| Introduction | 2 |
| C•que 8 Features | 3 |
| Controls and Connectors | |
| Front Panel Layout | 4 |
| Rear Panel Layout | 5 |
| Operating the C•que 8 | |
| Setting Up the C•que 8 | 6-7 |
| C•que 8 Master section | 7 |
| Stereo and Two Channel Modes | 8 |
| C•que 8 Channels | 9 |
| C•que 8 Connections | |
| Linking Multiple C•que 8's | 10 |
| Headphone Impedance and Sensitivity ratings | 11 |
| Cue Mix Set-up for Multitrack Vocal Recording | 12 |
| Cue Mix Set-up for Multitrack Rhythm section Recording | 13 |
| Stacking and Tilting the C•que 8 | 14 |
| C•que 8 Wiring Guide | 15 |
| Specifications | 16 |
| Block Diagram | 17 |

Copyright 2001, Samson Technologies Corp.

Printed June, 2002

Samson Technologies Corp.
575 Underhill Blvd.
P.O. Box 9031
Syosset, NY 11791-9031
Phone: 1-800-3-SAMSON (1-800-372-6766)
Fax: 516-364-3888
www.samsontech.com

Introduction

Congratulations on purchasing the Samson C•que 8 Headphone Amplifier! Although this unit is designed for easy operation, we suggest you take some time out first to go through these pages so you can fully understand how we've implemented a number of unique features. The C•que 8 is a compact, high-quality device that allows you to monitor any stereo or monophonic source signal (balanced or unbalanced) over as many as twelve separate headphones. Providing unusually high power levels and superb audio fidelity, the C•que 8 is compatible with virtually all popular headphone models. Front panel controls include a Master Input Level control and Stereo/2 Channel switch. Each headphone output has its own individual Shape Circuit Level Meters, and Level control. Special output jacks on the rear panel allows any number of C•que 8 units to be linked together with no loss of signal. The C•que 8 can be used in a wide variety of applications, including recording studios, teaching labs, broadcast environments, and for live performance. In this manual, you'll find a more detailed description of the features of the C•que 8, as well as a guided tour through the front and rear panels, step-by-step instructions for using the C•que 8, a reference chart that gives impedance and sensitivity ratings for a number of popular headphone models, and full specifications. You'll also find a warranty card enclosed—please don't forget to fill it out and mail it so that you can receive online technical support and so we can send you updated information about other Samson products in the future.

With proper care and adequate air circulation, your C•que 8 will operate trouble free for many years. We recommend you record your serial number in the space provided below for future reference.

Serial number: _____

Date of purchase: _____

Should your unit ever require servicing, a Return Authorization number (RA) must be obtained before shipping your unit to Samson. Without this number, the unit will not be accepted. Please call Samson at 1-800-3SAMSON (1-800-372-6766) for a Return Authorization number prior to shipping your unit. Please retain the original packing materials and if possible, return the unit in the original carton and packing materials.

C•que 8 Features

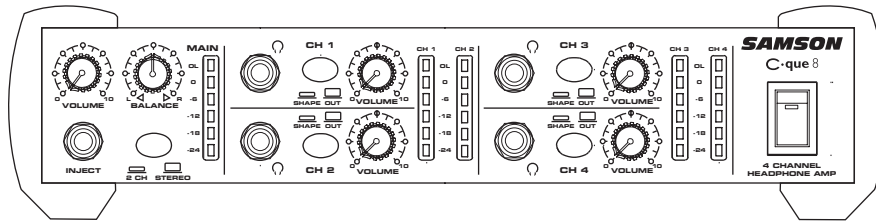

The Samson C•que 8 headphone amplifier utilizes the latest technology in gain management design. Here are some of its features:

- Four channel headphone mixer amplifier providing individual controls for each channel. Ideal for digital-audio-workstations, stage and studios.
- Dual headphone outputs; one rear, plus one front panel output per channel allowing a total of eight headphones connected at the same time.
- Maximum output power on each channel regardless of different headphone impedances.
- Left and Right Line inputs for master stereo bus on balanced TRS (Tip Ring Sleeve) 1/4" phone connectors.
- Inject input on TRS (Tip Ring Sleeve) unbalanced stereo phone connector allowing for the insertion of an additional stereo signal that is mixed with the stereo Line input for "more me" mixing.
- 2-Channel/Stereo mode switch configures the C que 8 to operate in traditional stereo mode, or in 2-Channel, mono mode.
- Balance controls pan in Stereo mode, or the level balance between the Line and Inject inputs in 2-Channel mode.
- EQ Shape circuit on each channel provides a "music contour" equalization curve that boosts the low and high frequencies of the headphone output.
- Each channel has a six-segment, LED Output meter, with a range of -24 to clip, making it easy to monitor the channel output level.
- A six-segment Main Level meter provides a clear and accurate indication of Line input level with an operating range of -24 to clip.
- Stacking Rubber Bumpers are included allowing several C que 8's, or other Samson C Class units, to be stacked on top of each other creating a neat array of high quality signal processors.
- Tilting Feet are also included so that the C class units can be positioned in a comfortable and ergonomic position on desktops and workstations.
- 19", 1 u (one rack space) rack-mount kit available.
- Three year extended warranty.

Controls and Connectors

FRONT PANEL LAYOUT

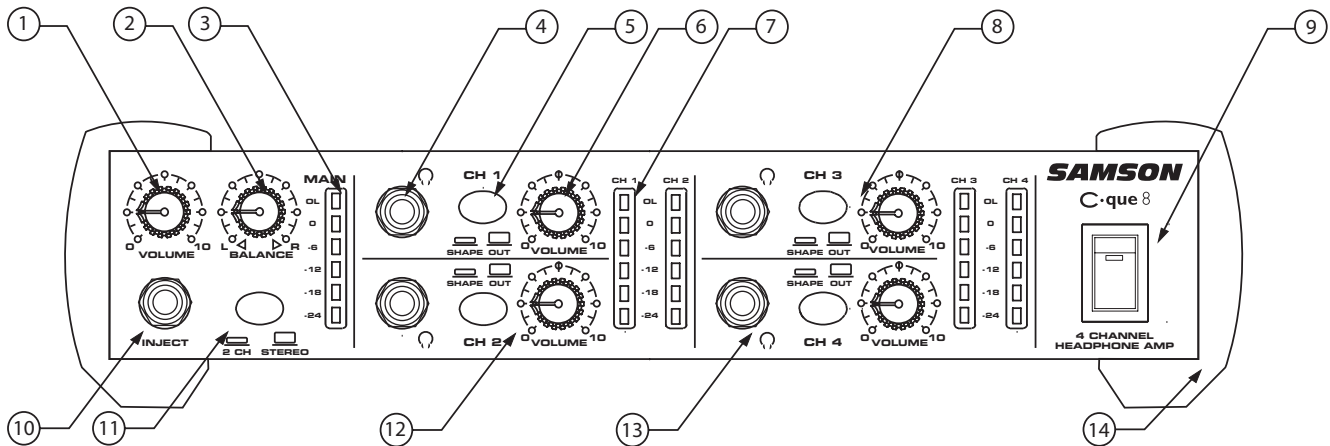

- ① **MASTER VOLUME** - Controls the level being sent to the individual channels.
- ② **BALANCE**- Controls Left and Right Pan in Stereo Mode or Level Balance between Main and Inject in 2 Channel Mode.
- ③ **MAIN MASTER LEVEL METER** - Indicates the amount of signal being driven into the four channels from the master volume control.
- ④ **HEADPHONE OUTPUT** - 1/4 TRS Connector for connecting any standard headphone.
- ⑤ **EQ SHAPE SWITCH** - Provides Equalization Contour for music listening.
- ⑥ **CHANNEL VOLUME** - Controls the volume being sent to the individual headphone channels.
- ⑦ **CHANNEL LEVEL METER** - Displays the amount of power being supplied to the channels.
- ⑧ **HEADPHONE CHANNEL 3** - The same knob and switch compliment is duplicated for Channel 3.
- ⑨ **MAIN POWER SWITCH** - When turned on, activates the C•que 8.
- ⑩ **MASTER INJECT** - Stereo TRS front panel input for injecting a signal into the main mix.
- ⑪ **2CH/STEREO SWITCH** - Changes the global operating mode from normal stereo to 2-channel.
- ⑫ **HEADPHONE CHANNEL 2** - The same knob and switch compliment is duplicated for Channel 2.
- ⑬ **HEADPHONE CHANNEL 4** - The same knob and switch compliment is duplicated for Channel 4.
- ⑭ **STACKING BUMPERS** - Sleek and highly functional, the rubber bumpers allow you to stack several C•que 8's or other Samson C class units. Angled feet are also included, providing a convenient tilting mechanism that allows easy operation on workstations or desktops.

REAR PANEL LAYOUT

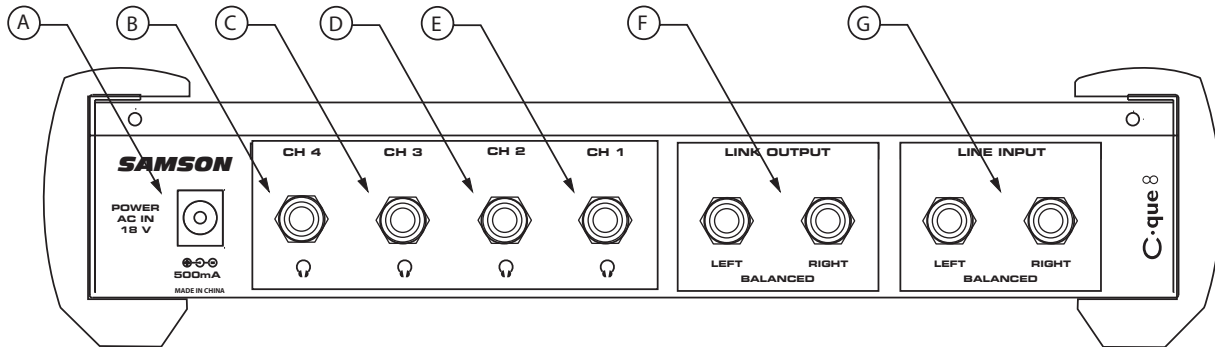

- A AC INLET** - AC power supply connector is here.
- B CHANNEL 4 OUTPUT** - Rear panel headphone output for Channel 4.
- C CHANNEL 3 OUTPUT** - Rear panel headphone output for Channel 3.
- D CHANNEL 2 OUTPUT** - Rear panel headphone output for Channel 2.
- E CHANNEL 1 OUTPUT** - Rear panel headphone output for Channel 1.
- F LINK OUTPUTS** - Outputs that are tied to the main input for linking to another headphone amp or other device.
- G LINE INPUT** - The main signal input to the headphone amp. Plugging into the left jack only sends the signal to both the left and right.

Operating the C•que 8

SETTING UP THE C•que 8

Setting up your C•que 8 Headphone Amplifier is a simple procedure, which takes only a few minutes.

Remove all packing materials (save them in case of need for future service) and plug the provided AC adapter cord in the rear AC inlet, but don't plug the power cable into a wall outlet just yet.

- Connect the output from the device you want monitored to the Left/Right LINE INPUT jacks on the C•que 8 rear panel. The C•que 8 accepts both balanced and unbalanced signals. Generally, a balanced signal is preferable because it provides better signal-to-noise ratio and reduced extraneous noise.
- Set the controls to the following positions:

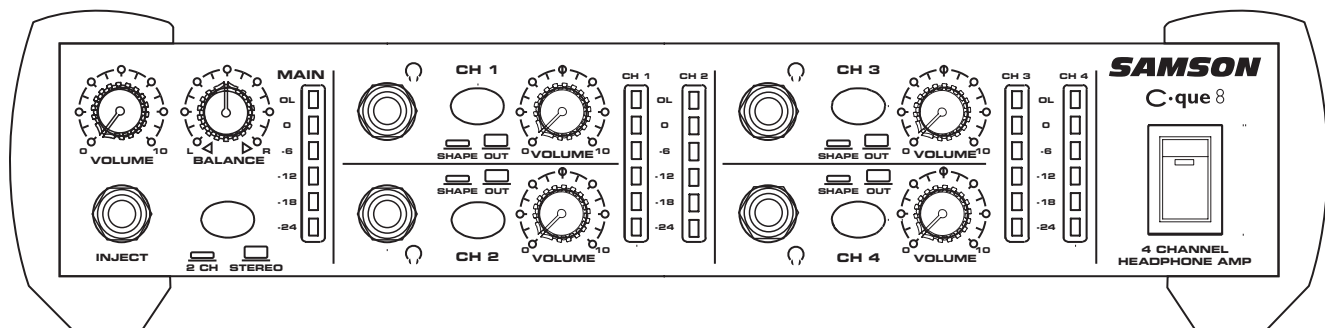

MASTER VOLUME – Off
ST/2CH SWITCH – Out
MASTER BALANCE- Center, 12:00

CHANNEL 1 VOLUME – 0
CHANNEL 1 SHAPE SWITCH- Out
CHANNEL 2 - 4's Controls - Set the Same as Channel 1

- Turn the master Volume knob and all four headphone Channel Output knobs to their minimum (fully counterclockwise) setting.
- Plug the C•que 8 power adapter into a wall outlet and switch the unit on by pressing the power switch.
- Apply a signal, like the output of a mixer playing a CD, to the C•que 8's rear-panel Left/Right LINE INPUT jacks. Raise the master VOLUME until the main meter reaches -18 to -12 dB.
- Connect a set of headphones to Channel 1 and slowly turn the channel's Volume knob clockwise until you hear the desired level.

WARNING: Because the C•que 8 is capable of generating extremely high volume levels, always start with the channel Volume knob at minimum and then slowly turn it up.

Operating the C•que 8

SETTING UP THE C•que 8 - Continued

- Repeat the previous step for all Channels that have headphones connected, making sure to start the VOLUME knob completely counterclockwise and then slowly raising it until the desired level is achieved. If you have connected different models of headphones to the various Channel Headphone jacks, you may find that some require more gain than others to achieve the same volume. This kind of disparity will occur if the various headphones have different impedances. The lower the impedance, the louder the headphone will sound compared to another, higher impedance headphone at the same VOLUME setting. Another factor affecting headphone loudness is called sensitivity. This is generally measured by determining the decibel (dB) level generated by 1 mW of power input. The higher the dB rating, the louder the headphone. See the Reference chart on page 13 of this manual for more details.
- To achieve optimum signal-to-noise ratio, the master VOLUME should generally be set as high as possible, short of audible distortion. However, if this results in your getting blasted with signal even though the channel volume is near minimum, you'll need to decrease the Master Volume while raising one or more channel volume levels. Conversely, if you find that you have to raise one or more headphone Channel Volume knobs to maximum or near maximum to achieve the desired level, try increasing the master Volume level while decreasing the channel volume(s).

C•que 8 Master Section

① Master Volume

The C•que 8's master VOLUME control is used to adjust the input signal connected to the main Left and Right inputs. In addition, the master VOLUME control adjusts the level of the signal inserted in the INJECT, which is summed with the MAIN Left and Right input signal.

② Balance Control

The C•que 8's main channel has a BALANCE control, which controls how much signal is sent to the left or right headphone outputs. The control knob has a center detent which indicates that the left and right sides are balanced. In 2 Channel mode, the signal becomes mono and the BALANCE knob adjusts the level balance between the signals connected to the LEFT inputs and signals connected to the RIGHT inputs. (For more information on 2-Channel mode, see the section "Mixing Signals in 2 Channel Mode" found on page 9 of this manual.)

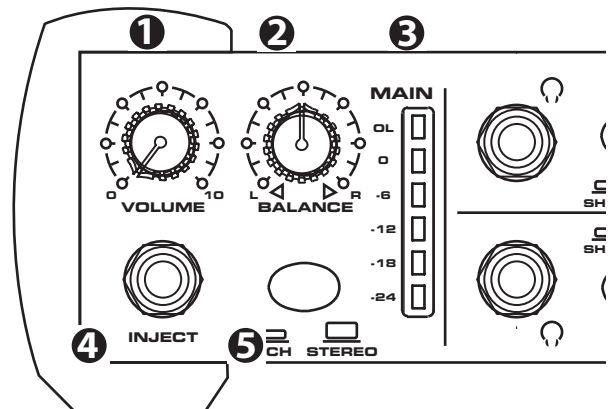

③ Master Level meter

The C•que 8's master section includes a 6 segment LED LEVEL meter which monitors the input level from the MAIN Left and Right Inputs in Decibels (dBs) from -24 to OL (overload). If the LEVEL meter displays an OL signal, then turn down the signal using the master VOLUME control.

④ Master Inject

The C•que 8's MASTER INJECT is a TRS input (Tip, Ring, Sleeve), that allows a second stereo signal to be inserted and summed together with the MAIN Left and Right signals. You can use a stereo signal from your mixers bus outputs or auxiliary sends to balance the mix between two stereo signals like rhythm tracks and vocals.

⑤ 2 Channel/Stereo switch

The 2 CH/STEREO switch is used to change between the C•que 8's two global operating modes, 2-Channel and Stereo. In Stereo mode the left and right Line inputs are mixed with the left and right Inject inputs, in stereo, with the Balance knob controlling the left and right panning. In 2-Channel mode, the left and right LINE inputs are mixed with the left and right INJECT inputs into a single mono signal with the BALANCE knob controlling the level difference between the LEFT and RIGHT inputs.

Operating the C•que 8

C•que 8 CHANNELS

⑥ Headphone Output

The C•que 8's Headphone Output jack accepts a standard 1/4" TRS connector for easy interface with most professional headphones. Once the master VOLUME has been set, the channels output level is set by the VOLUME knob.

⑦ EQ Shape

Each of the four C•que 8 channels features an EQ SHAPE switch allowing individual equalization contour for each channel. When the EQ SHAPE switch is in, the LED will illuminate indicating the EQ SHAPE circuit is engaged. The EQ SHAPE circuit provides a pre-set equalization curve designed to sound good on most program music. In this mode, the low frequencies have a 6dB boost at 100Hz and the high frequency are boosted 6dB at 12kHz. When the EQ SHAPE switch is in the out position, frequency response of the channel is flat.

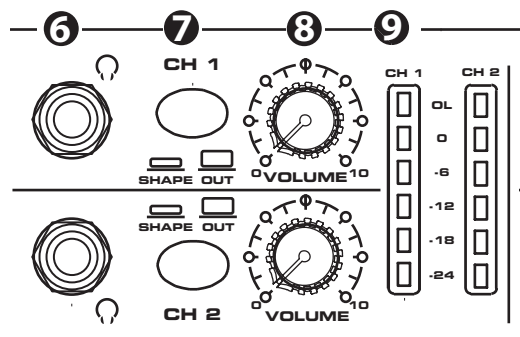

⑧ VOLUME Control

The channel VOLUME control is used to adjust the channel headphone output. The volume control will adjust the level of the front panel headphone outputs, as well as that channel's rear panel headphone outputs.

⑨ CHANNEL LEVEL Meter

Each C•que 8 Channel has an 6 segment, LED level meter which monitors the output of the channel in Decibels (dBs) -24 to OL (overload). If the LEVEL meter displays an OL signal, then turn down the channel VOLUME, and if necessary, also turn down the master VOLUME .

Operating the C•que 8

STEREO AND TWO-CHANNEL MODES

All of the C•que 8's four channels can be set to operate in two different modes: Stereo and 2 Channel.

Stereo Mode

Stereo mode is a normal operating mode where all mix inputs from MAIN and INJECT, maintain their stereo image throughout the signal path to each headphone output. The BALANCE control is used to adjust the stereo image between the Left and Right side. To design a monitor mix in the Stereo mode, follow these steps:

- Press the ST/2CH switch to the OUT position. You'll notice the switch LED is not illuminated indicating that the main input is in STEREO mode.
- Make a Stereo connection from your mixer's auxiliary or bus outputs to the main Left and Right Line inputs on the C•que 8's rear panel.
- In the Stereo mode, the BALANCE control adjusts the loudness between the left and right headphone outputs.

Mixing Signals in 2-Channel Mode

In 2-Channel mode, the MAIN left and right inputs and the INJECT left and right inputs are summed to a common mono signal that is present on all of the C que 8's headphone outputs. The BALANCE control is now used to adjust the volume difference between the left and the right inputs. In a recording situation, you can use the 2-Channel mode to make a "More Me" cue mix, letting you adjust the volume of the mix directly on the C que 8. To design a monitor mix in the 2-Channel mode, follow these steps:

- Press the ST/2CH switch to the IN position. You'll notice the switch LED is now illuminated indicating that the C•que 8 is in 2-Channel mode.
- Create a mono monitor mix on one of your mixer's auxiliary sends and make a connection from that aux send output to the MAIN Left input on the C•que 8's rear panel.
- Use your mixer's direct output, or another aux send, to route the signal of the lead vocal channel and make a connection from that output to the C•que 8's MAIN Right input.
- Now, you can use the BALANCE control to adjust the level difference between the monitor mix and the vocal channel. By using a combination of the MAIN VOLUME and BALANCE controls you can dial up the perfect mix directly on the C que 8.

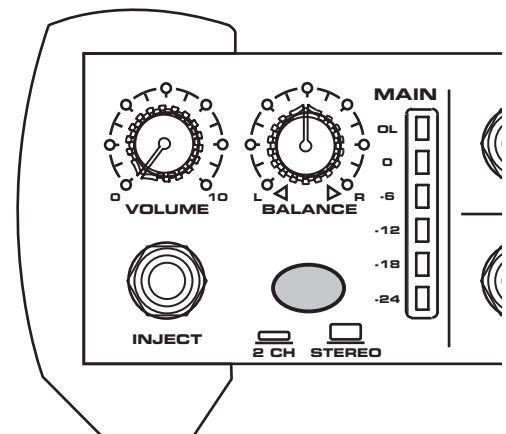

C•que 8 Connections

LINKING MULTIPLE C•que 8's

Any number of C•que 8's can be linked together (daisy-chained), allowing you to monitor an input signal over more than twelve sets of headphones, or to give individual musicians more control over their own headphone mix. To do this, simply follow these basic steps:

- Make a connection between one C•que 8's Left/Right Link outputs and the next one's Left/Right Main inputs.

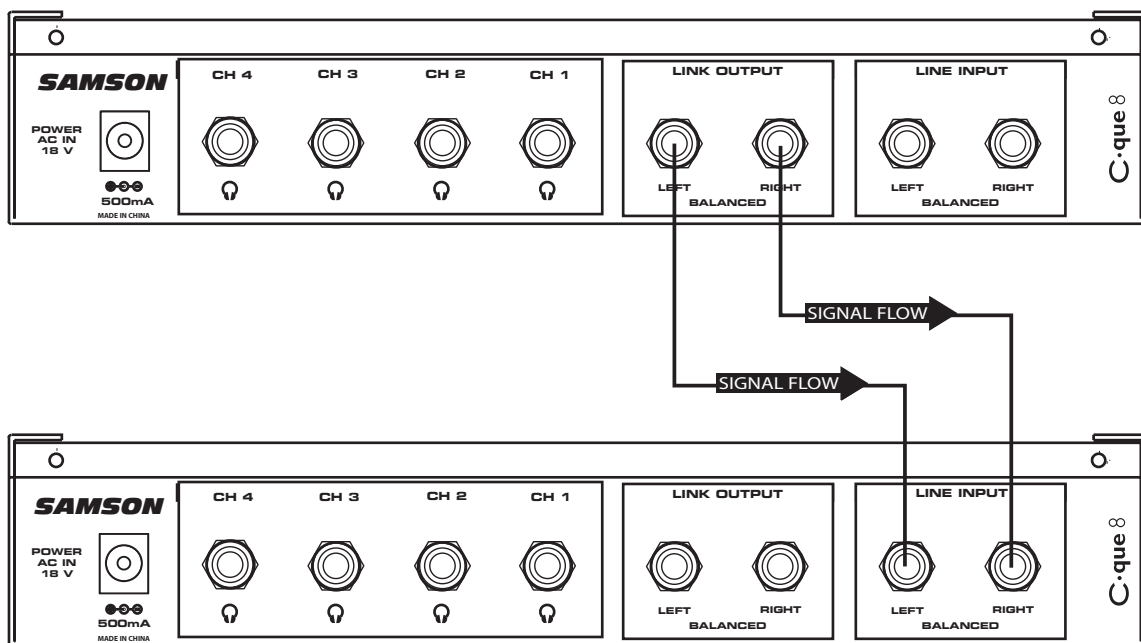

Because the C•que 8 Stereo Link output jacks are electronically balanced, we recommend the use of 3-conductor cable and 1/4" TRS (Tip/Ring/Sleeve) connectors. Even when several C•que 8's are linked together this way, there is no loss of power or audio fidelity—every Channel on every C•que 8 will sound just as loud and clear as if it were the only unit connected. The status of the front-panel Stereo/2 CH buttons affects only that unit and has no effect on any subsequent linked units.

HEADPHONE IMPEDANCE AND SENSITIVITY RATINGS

Virtually all headphones that terminate in a stereo 1/4" plug can be used with the C•que 8 Headphone Amplifier. This chart provides a partial listing of some of the more popular models, along with their impedance and sensitivity ratings. As described on page 7 of this manual, headphones with lower impedances (or higher sensitivity) will sound louder as compared to other, higher impedance (or lower sensitivity) headphones at the same channel Volume setting. Samson Technologies has no connection with any of these manufacturers, nor do we endorse any particular models for use with the C•que 8. This is simply a reference listing for your convenience. For more information about any of these headphones, contact the manufacturer directly.

SAMSON HEADPHONES

| Model | Impedance | Sensitivity /mW |
|--------------|------------------|------------------------|
| PH60 | 32 ohm | 100 dB |
| RH100 | 64 ohm | 106 dB |
| RH300 | 32 ohm | 106 dB |
| RH600 | 40 ohm | 106 dB |
| CH70 | 32 ohm | 103 dB |
| CH700 | 64 ohm | 108 dB |

OTHER MANUFACTURER'S HEADPHONES

| Manufacturer | Model | Impedance | Sensitivity /mW |
|---------------------|-------------------|------------------|------------------------|
| AKG | K-141 | 600 ohm | 98 dB |
| AKG | K-240 | 600 ohm | 88 dB |
| Beyer | DT-150 | 250 ohm | 114 dB |
| Beyer | DT-801 | 250 ohm | 114 dB |
| Fostex | T-10 | 50 ohm | 91 dB |
| Fostex | T-20 | 50 ohm | 96 dB |
| Fostex | T-40 | 50 ohm | 98 dB |
| Sennheiser | HD-450 (original) | 70 ohm | 94 dB |
| Sennheiser | HD-450 Series II | 60 ohm | 94 dB |
| Sony | MDR-7502 | 45 ohm | 100 dB |
| Sony | MDR-7504 | 45 ohm | 103 dB |
| Sony | MDR-7506 | 63 ohm | 106 dB |

C•que 8 Connections

CUE MIX SET-UP FOR MULTITRACK VOCAL RECORDING

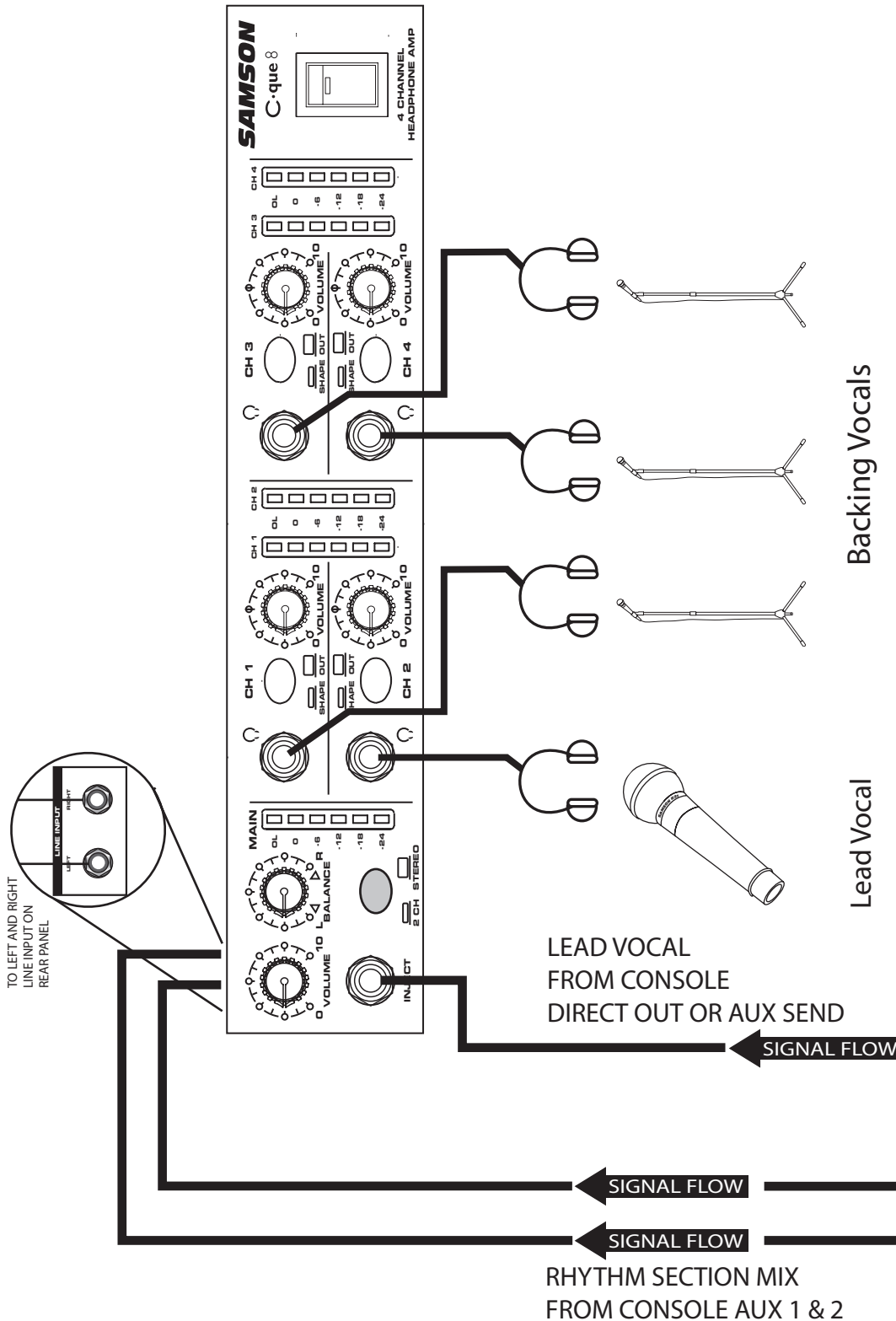

The following example shows a headphone mix for a vocal overdub session. The backing music and vocals are sent via the mixers auxiliary sends to the C•que 8's MAIN input. The lead vocal channel is connected from the console's direct output to the C•que 8's master INJECT input. The C•que 8 is set to 2-channel mode, so that the BALANCE controls the level difference between the backing track and lead vocal. This allows the lead vocalist to control the balance between his track and the backing tracks for a "more me" mix.

C•que 8 Connections

CUE MIX SET-UP FOR MULTITRACK RHYTHM SECTION RECORDING

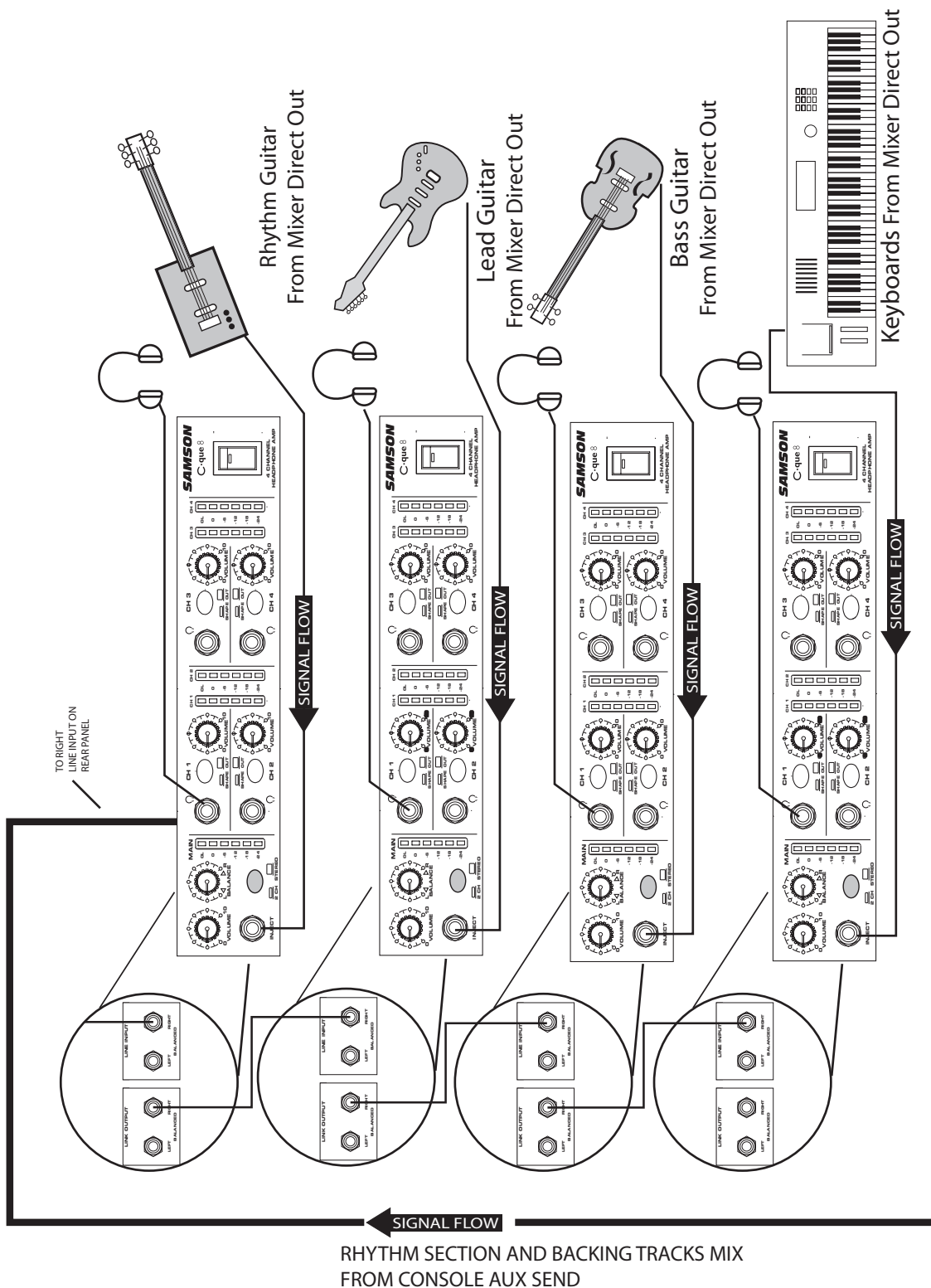

The following example shows a sophisticated cue mix for tracking a rhythm section during a recording session using five C•que 8's. The complete mix for all the musicians is sent via the console's auxiliary send to the C•que 8's RIGHT LINE input and daisy-chained from unit to unit. Then signal from each instrument is connected from the console's direct outputs to each of C•que 8's master INJECT inputs using a mono 1/4-inch (TIP/SLEEVE) cable. (By using a mono 1/4-inch cable only the Left Inject input is connected). The C•que 8's are set to 2-channel mode, so that the BALANCE controls the level difference between the backing tracks and individual instruments. This allows the lead vocalist or musician to dial up his or her own track for a "more me" mix.

Stacking and Tilting the C que 8

Stacking the C que 8

You can stack one C que 8, or any other Samson C Class units, on top of each other by simply lining up the bumpers. Important Note: When stacking the C que 8, be sure that only the bottom unit has the tilting feet installed.

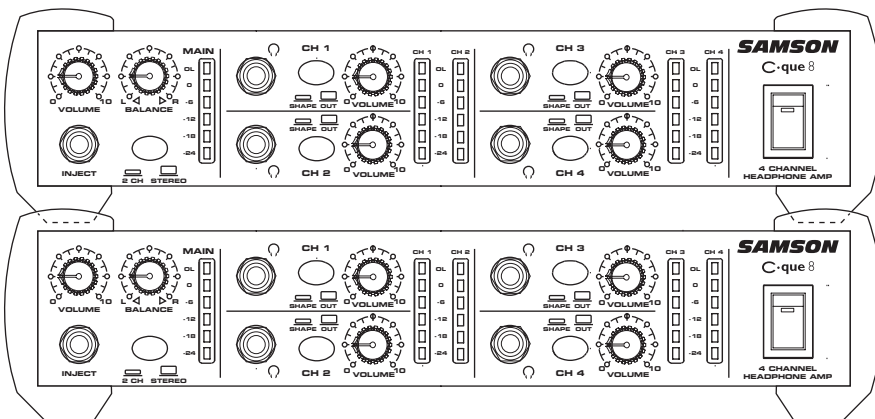

- Remove the bottom screw from right front bumper.
- Identify the right tilting foot by the locating “R” marking on the inside top.
- Position the angled foot under the right bumper as shown in the drawing.

Installing the Tilting Feet

You can install the tilting rubber feet included with your C que 8 so that you can set the unit at a comfortable operating angle on a workstation or desktop. Follow the simple instructions below to install the tilting feet.

- Remove the bottom screw from right front bumper.
- Identify the right tilting foot by the locating “R” marking on the inside top.
- Position the angled foot under the right bumper as shown in the drawing.
- Use the included 3 x 16mm screw to attach the foot.
- Repeat the steps above for the front left bumper.

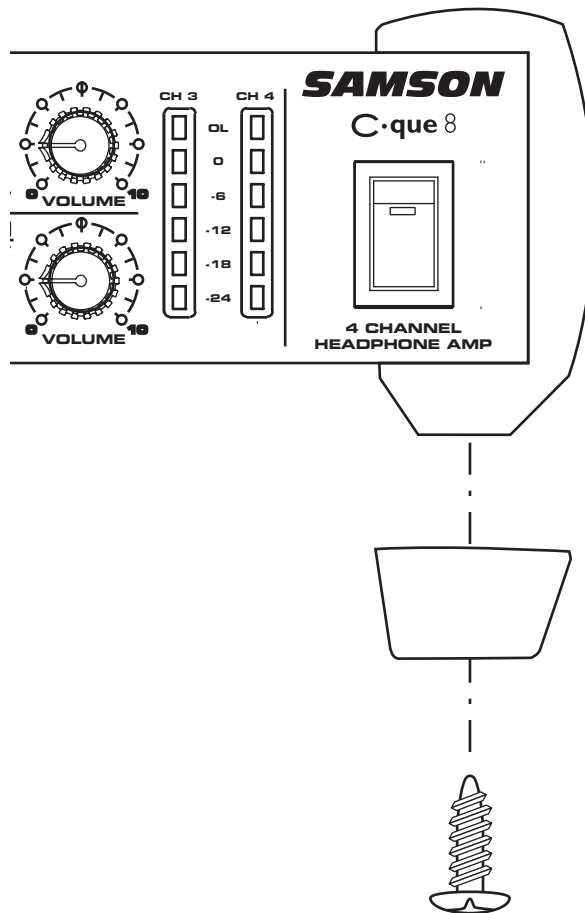

C•que 8 Wiring Guide

Unbalanced 1/4" Connector

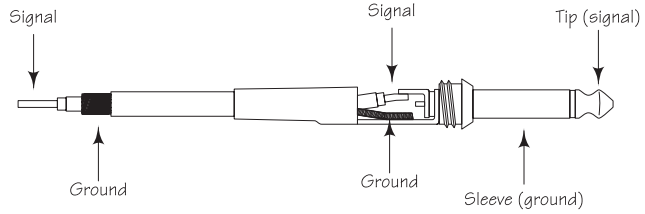

Balanced TRS 1/4" Connector

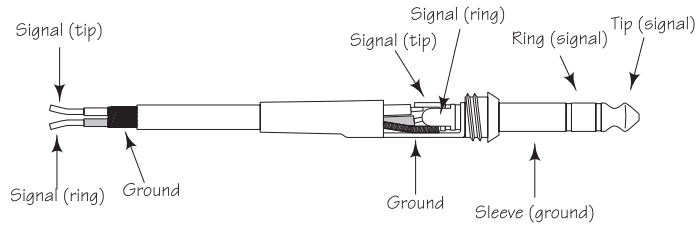

Insert Cable 1/4" TRS connector to two 1/4" can be used to connect a stereo signal to the Master Inject.

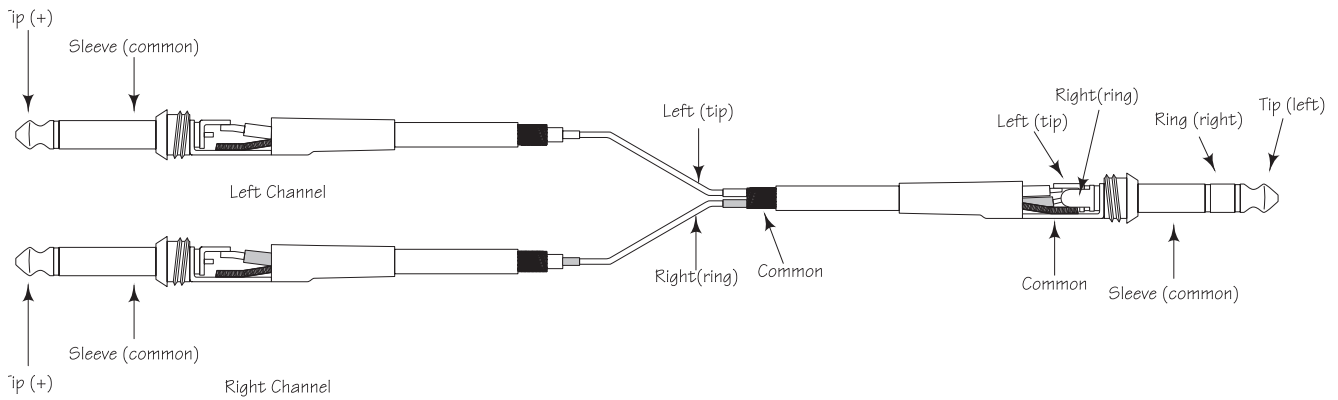

XLR Balanced Wiring Guide

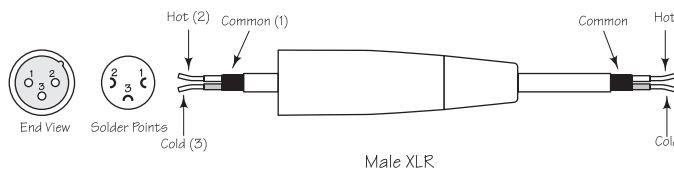
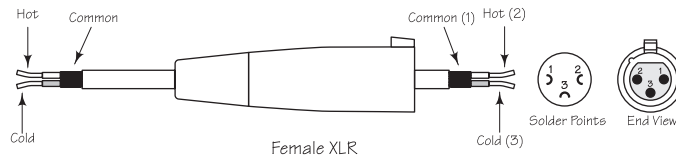

Specifications

Master Section (Rear Panel)

| | |
|------------------|---|
| Input | 2 TRS Balanced 1/4" (Left-Right) or (Left mono) |
| Impedance | 15 k Ohms balanced |
| Max. input level | +26 dBu balanced |
| CMRR: | Min 40dB, >55 dB @ 1 kHz |

Master Section (Front Panel)

| | |
|-----------------------|--|
| Master Volume control | 0 - 10 |
| Master Level Meters | 6 Segment LED (-24 to OL) |
| Master Inject | 1/4" TRS jack (Left-Right) |
| Controls | ST/2CH Switch, Volume Control, Balance Control |

Link Output

| | |
|------------------|---|
| Connectors | 2-1/4" TRS Balanced (Left-Right) Parallel to Main Input |
| Max Output Level | Matches Main Input |

Channels

| | |
|-------------------|---|
| Impedance | 10 k Ohms unbalanced |
| Max. input level | +21 dBu unbalanced |
| Level Meters | 6 Segment LED (-24 to OL) (load compensating) |
| Outputs | 2 - 1/4" TRS (Left-Right) Headphone outputs per Channel |
| Max. output level | 140 mW at 32 ohms, 385mW at 66 ohms. |
| Impedance minimum | 8 Ohms |
| Controls | EQ Shape Switch, Volume Control |

Global Specifications

| | |
|--------------------|--------------------------------------|
| Frequency response | 10 Hz to 32 kHz, +/- 3 dB |
| Noise | > 90 dB, unweighted, 22 Hz to 22 kHz |
| THD | 0.008 % typ. @ +4 dBu, 1 kHz |

Power Supply

| | |
|---------------------------|-------------------------------------|
| Mains Voltages USA/Canada | 105-125 VAC ~, 60 Hz |
| Mains Voltages Europe | 215 – 254 VAC~, 50Hz |
| Power Inlet | Standard IEC receptacle / with fuse |
| Power Consumption | 29 Watts Max. |

Physical

| | |
|-----------------|---|
| Dimensions | 1 3/4" (44.5 mm) * 19" (482.6 mm) * 8 1/2" (217 mm) |
| Net Weight | 5.5lbs., (2.5 kg) |
| Shipping Weight | 8lbs., (3.6 kg) |

C•que 8 Block Diagram

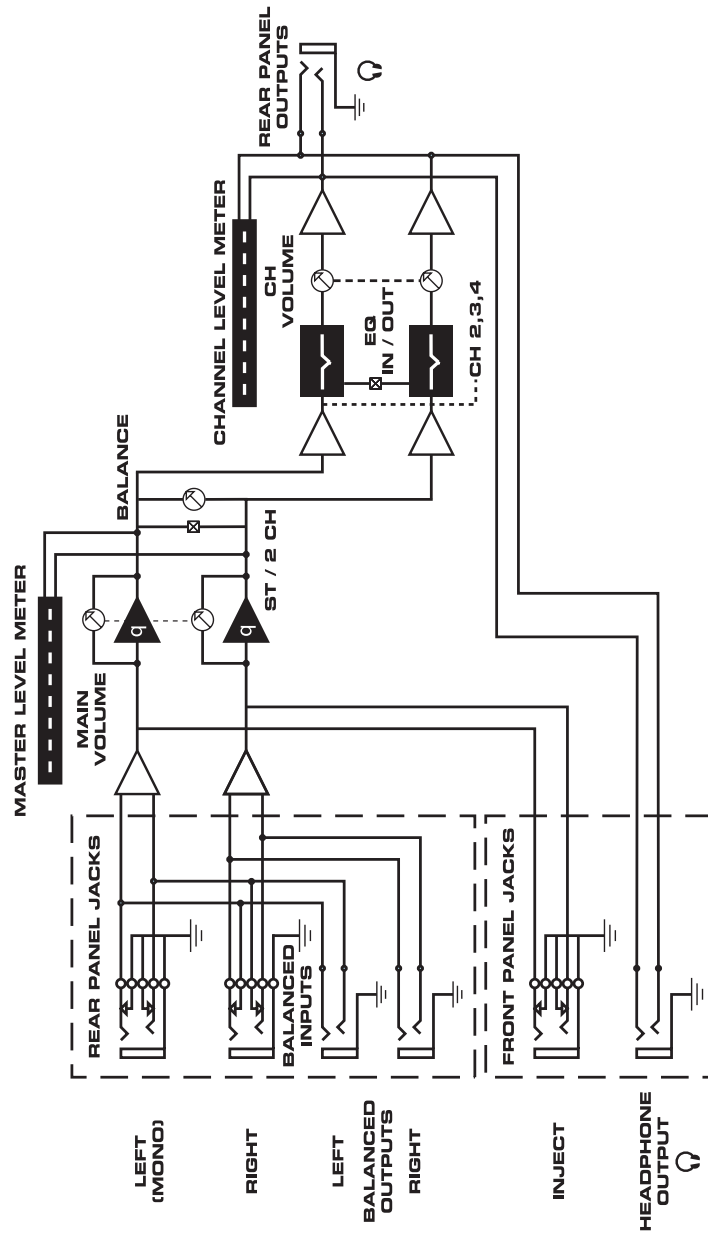

CONNECTIONS

| INPUT/OUTPUT | | TIP | RING | SLEEVE | GND |
|-------------------|--|------|-------|--------|-----|
| REAR PANEL JACKS | | HOT | COLD | | |
| BALANCED INPUTS | | LEFT | RIGHT | | |
| FRONT PANEL JACKS | | LEFT | RIGHT | | |
| HEADPHONE OUTPUT | | LEFT | RIGHT | | |

www.samsontech.com

Samson Technologies Corp.
575 Underhill Blvd.
P.O. Box 9031
Syosset, NY 11791-9031
Phone: 1-800-3-SAMSON (1-800-372-6766)
Fax: 516-364-3888
www.samsontech.com