

# PARTS AND OPERATION MANUAL

# MQ POWER DCA-400SPK WHISPERWATT™ GENERATOR

© COPYRIGHT 2001, MULTIQIP INC.

PARTS LIST NO. C3873300104

Revision #0 (06/19/01)



**MULTIQIP INC.**

18910 WILMINGTON AVE.  
CARSON, CALIFORNIA 90746  
310-537-3700  
800-421-1244  
FAX: 310-537-3927

**PARTS DEPARTMENT:**

800-427-1244  
FAX: 800-672-7877

**SERVICE DEPARTMENT:**

800-835-2551  
FAX: 310-638-8046

E-mail: [mq@multiquip.com](mailto:mq@multiquip.com) • [www.multiquip.com](http://www.multiquip.com)



# **WARNING**



## **CALIFORNIA — Proposition 65 Warning**

**Diesel engine exhaust and some of its constituents are known to the State of California to cause cancer, birth defects and other reproductive harm.**

## **HERE'S HOW TO GET HELP**

*PLEASE HAVE THE MODEL AND SERIAL NUMBER  
ON-HAND WHEN CALLING*

### ***PARTS DEPARTMENT***

*800/427-1244 or 310/537-3700*

*FAX: 800/672-7877 or 310/637-3284*

### ***SERVICE DEPARTMENT***

*800/835-2551 or 310/537-3700*

*FAX: 310/638-8046*

### ***WARRANTY DEPARTMENT***

*800/835-2551 or 310/537-3700*

*FAX: 310/638-8046*

### ***MAIN***

*800/421-1244 or 310/537-3700*

*FAX: 310/537-3927*

# TABLE OF CONTENTS

Here's How To Get Help ..... 3  
Table Of Contents ..... 4  
Rules For Safe Operation ..... 6-9  
Towing ..... 10  
Trailer Safety Guidelines ..... 11-17  
Trailer Wiring Diagram ..... 18  
Electric Brake Troubleshooting ..... 19  
Hydraulic Brake Troubleshooting ..... 20  
Operation And Safety Decals ..... 21-22  
Specifications ..... 23  
General Information ..... 24-25  
Major Components ..... 26  
Dimensions (Top, Side And Rear) ..... 28-29  
Control Panel ..... 30-31  
Engine Operating Panel ..... 32-33  
Output Terminal Panel ..... 34-39  
Installation ..... 40-41  
Pre-Setup ..... 42-45  
Load Application ..... 46  
Generator Start-Up Procedure ..... 47-50  
Generator Shut-Down Procedure ..... 52  
Maintenance ..... 54-57  
Generator Wiring Diagram ..... 58  
Engine Wiring Diagram ..... 60  
Troubleshooting (Engine) ..... 62-63  
Troubleshooting (Engine/Generator) ..... 64  
Explanation Of Codes In Remarks Column ..... 66  
Suggested Spare Parts ..... 67

## **MQ Power DCA-400SPK AC Generator**

Generator Assembly ..... 68-71  
Control Box Assembly ..... 72-75  
Engine Radiator Assembly ..... 76-79  
Engine Operating Panel Assembly ..... 80-81  
Output Terminal Assembly ..... 82-83  
Battery Assembly ..... 84-85  
Muffler Assembly ..... 86-87  
Fuel Tank Assembly ..... 88-89  
Enclosure Assembly ..... 90-97  
Enclosure (Rubber Seals) ..... 98-99  
Oil Piping Assembly ..... 100-101  
Name Plate and Decals ..... 101-105  
  
Terms and Conditions Of Sale — Parts ..... 106

**NOTE**

*Specification and part number  
are subject to change without  
notice.*

- Dealer account number
- Dealer name and address
- Shipping address (if different than billing address)
- Return fax number
- Applicable model number
- Quantity, part number and description of each part
- Specify preferred method of shipment:
  - UPS Ground
  - UPS Second Day or Third Day\*
  - UPS Next Day\*
  - Federal Express Priority One (please provide us with your Federal Express account number)\*
  - Airborne Express\*
  - Truck or parcel post

*\*Normally shipped the same day the order is received, if prior to 2PM west coast time.*

## Earn Extra Discounts when you order by FAX!

All parts orders which include complete part numbers and are received by fax qualify for the following extra discounts:

<u>Number of line items ordered</u>	<u>Additional Discount</u>
1-9 items	3%
10+ items**	5%

### Get special freight allowances when you order 10 or more line items via FAX! \*\*

- UPS Ground Service at no charge for freight
- PS Third Day Service at one-half of actual freight cost

No other allowances on freight shipped by any other carrier.

\*\*Common nuts, bolts and washers (all items under \$1.00 list price) do not count towards the 10+ line items.

\*DISCOUNTS ARE SUBJECT TO CHANGE\*

Fax order discount and UPS special programs revised June 1, 1995

**Extra Fax Discount  
for Domestic USA  
Dealers Only**

**Up to 5%  
extra savings!**

**UPS  
Special**  
*For faxed orders only*

**Now! Direct TOLL-FREE access  
to our Parts Department!**

Toll-free nationwide:

800-421-1244

Toll-free FAX:

800/6-PARTS-7 • 800-672-7877

# RULES FOR SAFE OPERATION

## CAUTION:



Failure to follow instructions in this manual may lead to serious injury or even death! This equipment is to be operated by trained and qualified personnel only! This equipment is for industrial use only.

The following safety guidelines should always be used when operating the DCA-400SPK portable generator:

### GENERAL SAFETY

- **DO NOT** operate or service this equipment before reading this entire manual.



- This equipment should not be operated by persons under 18 years of age.

- **NEVER** operate this equipment without proper protective clothing, shatterproof glasses, steel-toed boots and other protective devices required by the job.



- **NEVER** operate this equipment when not feeling well due to fatigue, illness or taking medicine.



- **NEVER** operate this equipment under the influence of drugs or alcohol.



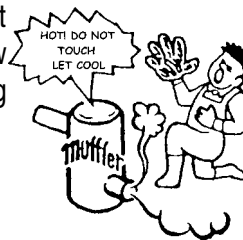
- **NEVER** use accessories or attachments, which are not recommended by MQ Power for this equipment. Damage to the equipment and/or injury to user may result.

- Manufacturer does not assume responsibility for any accident due to equipment modifications.

- Whenever necessary, replace nameplate, operation and safety decals when they become difficult read.

- Always check the machine for loosened threads or bolts before starting.

- **NEVER** touch the hot exhaust manifold, muffler or cylinder. Allow these parts to cool before servicing engine or generator.



- **High Temperatures** – Allow the engine to cool before adding fuel or performing service and maintenance functions. Contact with *hot* components can cause serious burns.

- The engine of this generator requires an adequate free flow of cooling air. Never operate the generator in any enclosed or narrow area where free flow of the air is restricted. If the air flow is restricted it will cause serious damage to the generator or engine and may cause injury to people. The generator engine gives off **DEADLY** carbon monoxide gas.

## CAUTION:



Always refuel in a well-ventilated area, away from sparks and open flames.

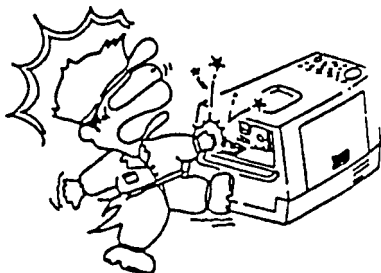


- Always use extreme caution when working with **flammable** liquids. When refueling, **stop the engine** and allow it to cool. **DO NOT smoke** around or near the machine. Fire or explosion could result from fuel vapors, or if fuel is spilled on a hot engine.

- **NEVER** operate the generator in an explosive atmosphere or near combustible materials. An explosion or fire could result causing severe *bodily harm or even death*.
- Topping-off to filler port is dangerous, as it tends to spill fuel.

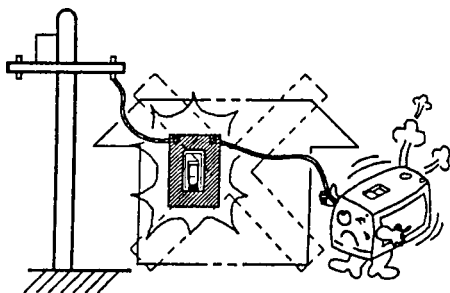
## RULES FOR SAFE OPERATION

### CAUTION:



■ **NEVER** touch output terminals during operation. This is extremely dangerous. Always stop the machine when contact with the output terminals.

### CAUTION:



■ **Backfeed to a utility system can cause electrocution and/or property damage. Do not connect to any building's electrical system except through an approved device or after building main switch is opened.**

### CAUTION:



**Never** use damaged or worn cables when connecting power tools or equipment to the generator. Make sure power connecting cables are securely connected to the generator's output terminals, insufficient tightening of the terminal connections may cause damage to the generator and electrical shock.

### CAUTION:



**DO NOT** touch or open any of the below mentioned components while the generator is running. Always allow sufficient time for the engine and generator to cool before performing maintenance.

#### Radiator

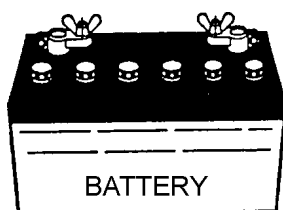
1. **Radiator Cap** - Removing the radiator cap while the engine is hot due to high pressure, will result in boiling water to gush out of the radiator, therefore causing severe scalding to any persons in the general area of the generator.
2. **Coolant Drain Plug** - Removing the coolant drain plug while the engine is hot will result in hot coolant to gush out of the coolant drain plug, therefore causing severe scalding to any persons in the general area of the generator.
3. **Engine Oil Drain Plug** - Removing the engine oil drain plug while the engine is hot will result in hot oil to gush out of the oil drain plug, therefore causing severe scalding to any persons in the general area of the generator.

## Battery CAUTION:



Never over fill the battery with water above the upper limit.

The battery contains acids that can cause injury to the eyes and skin. To avoid eye irritation, always wear safety glasses. Use well insulated gloves when picking up the battery. Use the following guidelines when handling the battery:



1. **DO NOT** drop the battery. There is the possibility of risk that the battery may explode.
  2. **DO NOT** expose the battery to open flames, sparks, cigarettes etc. The battery contains combustible gases and liquids. If these gases and liquids come in contact with a flame or spark, an explosion could occur.
  3. Always keep the battery charged. If the battery is not charged a buildup of combustible gas will occur.
  4. Always keep battery charging and booster cables in good working condition. Repair or replace all worn cables.
  5. Always recharge the battery in an open air environment, to avoid risk of a dangerous concentration of combustible gases.
  6. In case the battery liquid (dilute sulfuric acid) comes in contact with **clothing or skin**, rinse skin or clothing immediately with plenty of water.
  7. In case the battery liquid (dilute sulfuric acid) comes in contact with your **eyes**, rinse eyes immediately with plenty of water, then contact the nearest doctor or hospital, and seek medical attention.
- **NEVER** Run engine without air filter. Severe engine damage may occur.
  - Always service air cleaner frequently to prevent carburetor malfunction.
  - Always disconnect the battery before performing service on the generator.
  - Always be sure the operator is familiar with proper safety precautions and operations techniques before using generator.
  - Always store equipment properly when not in use. Equipment should be stored in a clean, dry location out of the reach of children.
  - **DO NOT** leave the generator running in the manual mode unattended.
  - **DO NOT** allow unauthorized people to operate this equipment.
  - Always read, understand, and follow procedures in Operator's Manual before attempting to operate equipment.
  - Refer to the **Komatsu Engine Owner's Manual** for engine technical questions or information.

### Loading and Unloading (Crane)

- Before lifting, make sure the generator's lifting hook is secure and that there is no apparent damage to the generator itself (loose screws, nuts and bolts). If any part is loose or damaged, please take corrective action before lifting.
- Always drain fuel prior to lifting.
- Always make sure crane or lifting device has been properly secured to the hook of guard frame on generator.
- **NEVER** lift the machine while the engine is running.
- Use adequate lifting cable (wire or rope) of sufficient strength.
- When lifting the generator, always use the balanced center-point suspension hook and lift straight upwards.
- **NEVER** allow any person or animal to stand underneath the machine while lifting.
- When loading the generator on a truck, be sure to use the front and back frame bars as a means to secure the generator during transport.



## Transporting

- Always shutdown engine before transporting.
- Tighten fuel tank cap securely.
- Drain fuel when transporting generator over long distances or bad roads.
- Always tie-down the generator during transportation by securing the generator.
- If generator is mounted on a trailer, make sure trailer complies with all local and state safety transportation laws. See page 10 for basic towing procedures.

## Emergencies

- Always know the location of the nearest **fire extinguisher** and **first aid kit**. Know the location of the nearest telephone. Also know the phone numbers of the nearest **ambulance**, **doctor** and **fire department**.

## Maintenance Safety

- **NEVER** lubricate components or attempt service on a running machine.
- Always allow the machine a proper amount of time to cool before servicing.
- Keep the machinery in proper running condition.
- Fix damage to the machine immediately and always replace broken parts.
- Dispose of hazardous waste properly. Examples of potentially hazardous waste are used motor oil, coolant, fuel, and fuel filters.
- **DO NOT** use plastic containers to dispose of hazardous waste.
- **DO NOT** pour waste, oil, coolant or fuel directly onto the ground, down a drain or into any water source

## Towing Safety Precautions

### CAUTION :



Check with your county or state safety towing regulations department before towing your generator. Vehicle towing

To reduce the possibility of an accident while transporting the generator on public roads, always make sure the trailer (Figure 1) that supports the generator and the towing vehicle are in good operating condition and both units are mechanically sound.

The following list of suggestions should be used when towing your generator:

- Make sure the hitch and coupling of the towing vehicle are rated equal to, or greater than the trailer "gross vehicle weight rating" (GVWR).
- **ALWAYS** inspect the hitch and coupling for wear. **NEVER** tow a trailer with defective hitches, couplings, chains etc.
- Check the tire air pressure on both towing vehicle and trailer. Also check the tire tread wear on both vehicles.
- **ALWAYS** make sure the trailer is equipped with a "Safety Chain".
- **ALWAYS** attach trailer's safety chain to bumper of towing vehicle.
- **ALWAYS** make sure the vehicle and trailer directional, backup, brake, and trailer lights are connected and working properly.
- The maximum speed unless otherwise posted for highway towing is **45 MPH**. Recommended off-road towing is not to exceed **10 MPH** or less depending on type of terrain.
- Place *chocked blocks* underneath wheel to prevent **rolling**, while parked.
- Place *support blocks* underneath the trailer's bumper to prevent **tipping**, while parked.
- Use the trailer's hand winch to adjust the height of the trailer, then insert locking pin to lock wheel stand in place, while parked.
- Avoid sudden stops and starts. This can cause skidding, or jackknifing. Smooth, gradual starts and stops will improve gas mileage.
- Avoid sharp turns to prevent rolling.
- Remove wheel stand when transporting.
- **DO NOT** transport generator with fuel in tank.

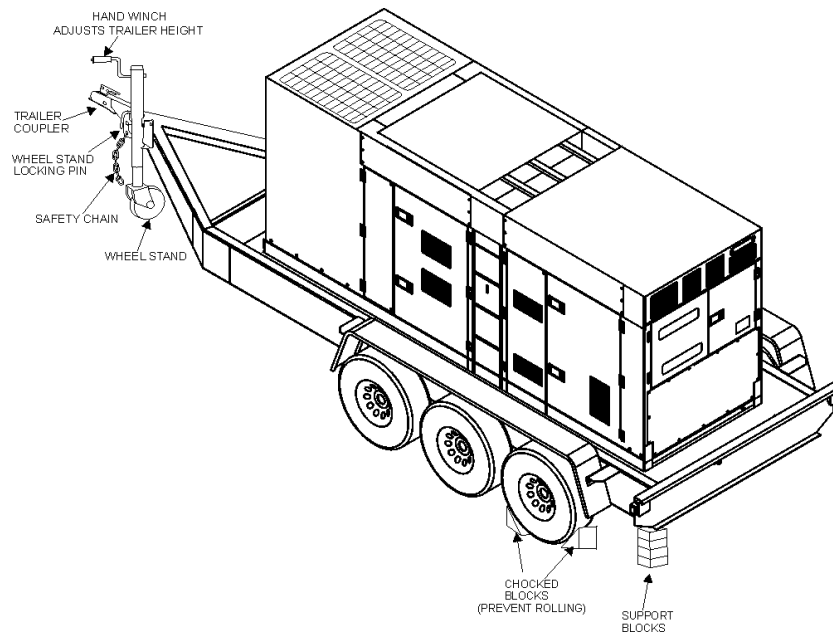


Figure 1. Generator with Trailer

## CAUTION:



**ALWAYS** make sure the trailer is in good operating condition. Check the tires for proper inflation and wear. Also check the wheel lug nuts for proper tightness.

### Explanation of Chart:

This section is intended to provide the user with trailer service and maintenance information. The service and maintenance guidelines referenced in this section apply a wide range of trailers. Remember periodic inspection of the trailer will ensure safe towing of the equipment and will prevent damage to the equipment and personal injury.

It is the purpose of this section to cover the major maintenance components of the trailer. The following trailer components will be discussed in this section:

- Brakes
- Tires
- Lug Nut Torquing
- Suspension
- Electrical
- Brake Troubleshooting Tables

Use the following definitions with reading Table 1.

1. **Fuel Cell** - Provides an adequate amount of fuel for the equipment in use. Fuel cells must be empty when transporting equipment.
2. **Braking System** - System employed in stopping the trailer. Typical braking systems are electric, surge, hydraulic, hydraulic-surge and air.
3. **GVWR**- Gross Vehicle Weight Rating (GVWR), is the maximum number of pounds the trailer can carry, including the fuel cell (empty).
4. **Frame Length** - This measurement is from the ball hitch to the rear bumper (reflector).
5. **Frame Width** - This measurement is from fender to fender.
6. **Jack Stand** - Trailer support device with maximum pound requirement from the tongue of the trailer.
7. **Coupler** - Type of hitch used on the trailer for towing.
8. **Tire Size** - Indicates the diameter of the tire in inches (10,12,14, etc.), and the width in millimeters (175,185,205, etc.). The tire diameter must match the diameter of the tire rim.
9. **Tire Ply** - The tire ply (layers) number is rated in letters; 2-ply,4-ply,6-ply, etc.
10. **Wheel Hub** - The wheel hub is connected to the trailer's axle.
11. **Tire Rim** - Tires mounted on a tire rim. The tire rim must match the size of the tire.
12. **Lug Nuts** - Used to secure the wheel to the wheel hub. Always use a torque wrench to tighten down the lug nuts. See Table 4 and Figure 5 or lug nut tightening and sequence.
13. **Axle** - Indicates the maximum weight the axle can support in pounds, and the diameter of the axle expressed in inches (see Table 3). Please note that some trailers have a double axle. This will be shown as 2-6000 lbs., meaning two axles with a total weight capacity of 6000 pounds.
14. **Suspension** - Protects the trailer chassis from shocks transmitted through the wheels. Types of suspension used are leaf, Q-flex, and air ride.
15. **Electrical** - Electrical connectors (looms) are provided with the trailer so the brake lights and turn signals can be connected to the towing vehicle.
16. **Application** - Indicates which units can be employed on a particular trailer.

# DCA-400SPK — TRAILER-SPECIFICATIONS

Table 1. Specifications

MODEL	APPLICATION	FUEL CELL	BRAKE SYSTEM	GVWR	FRAME LENGTH	FRAME WIDTH	JACK STAND
TRLR-10W	SDW225, SGW250,TLW300	NO	NO	1900LBS	96"	50"	800LB. FULL TILT WHEEL
TRLR-10	DCA10, TLG12, DCA-15	NO	NO	1900LBS	96"	50"	800LB. FULL TILT WHEEL
TRLR-10XF	DCA10, TLG-12, DCA15, TLW-300	52 GAL	NO	1900LBS	96"	50"	800LB. FULL TILT WHEEL
TRLR-225W	WELDERS, DA7000SS	NO	NO	2200LBS	85"	42"	800LB. FULL TILT WHEEL
TRLR-BLW400	BLW-400	NO	ELECTRIC	2700LBS	W/MAST 154" W/O 124"	55" (78" TALL)	800LB. FULL TILT WHEEL
TRLR-50X	DCA-25	NO	NO	2700LBS	124"	55"	800LB. FULL TILT WHEEL
TRLR-50XF	DCA-25	41 GAL	NO	2700LBS	124"	55"	800LB. FULL TILT WHEEL
TRLR-70W	DCA-45, -60, 70	NO	SURGE	7000LBS	186"	77"	2000LB. FLAT PAD
TRLR-70X	DCA-45, -60, 70	OPT	SURGE	7000LBS	138"	66"	2000LB. FLAT PAD
TRLR-70XF	DCA-45, -60, 70	53 GAL	SURGE	7000LBS	138"	66"	2000LB. FLAT PAD
TRLR-100XF	DCA-100, 125	150 GAL	HYDRAULIC SURGE	7000LBS	190"	76"	2000LB. FLAT PAD
TRLR-85/125	DCA-85, 100, 125	145 GAL	HYDRAULIC	10000LBS	186"	77"	2000LB. FLAT PAD
TRLR-150XF	DCA-150, 180	200 GAL	HYDRAULIC SURGE	11160LBS	204"	84"	5000 LB. FLAT PAD
TRLR-220XF	DCA-220	250 GAL	HYDRAULIC SURGE	14000LBS	222"	83"	5000 LB. FLAT PAD
TRLR-300XF	DCA-300	250 GAL	HYDRAULIC SURGE	18000LBS	238"	83"	5000 LB. FLAT PAD
TRLR-400XF	DCA-400	350 GAL	ELECTRIC	18000LBS	238"	83"	5000 LB. FLAT PAD
TRLR-600XF	DCA-600, 800	550 GAL	AIR	30000LBS	384"	96"	5000 LB. FLAT PAD
TRLR-800SX	DCA-600, 800	550 GAL	AIR	30000LBS	384"	96"	5000 LB. FLAT PAD

# DCA-400SPK — TRAILER-SPECIFICATIONS

Table 1. Specifications (Con't)

MODEL	COUPLER	TIRES	WHEELS	AXLE	HUBS	SUSPENSION	ELECTRICAL
TRLR-10W	2" BALL CLASS 2 ADJUSTABLE	175-13C	13"X4.50"	2200# 2X2	5 LUG	3 LEAF	4 WIRE LOOM W/ 4 POLE FLAT
TRLR-10	2" BALL CLASS 2 ADJUSTABLE	175-13C	13"X4.5"	2200#2X2	5 LUG	3 LEAF	4 POLE FLAT
TRLR-10XF	2" BALL CLASS 2 ADJUSTABLE	175-13C	13"X4.5"	2200#2X2	5 LUG	3 LEAF	4 POLE FLAT
TRLR-225W	2" BALL CLASS 2 ADJUSTABLE	175-13B	13X4.5"	2200#2X2	5 LUG	Q FLEX	4 POLE FLAT
TRLR-BLW 400	2" BALL CLASS 2 ADJUSTABLE	175-13C	13 X 4.5"	2200#2X2	5 LUG	3 LEAF	4 POLE FLAT
TRLR-50X	2" BALL CLASS	B78-13LRC	13"X4.50"	3500lbs. 2-3/8"	5 LUG	4 LEAF	4 POLE RUBBER FLAT
TRLR-50XF	2" BALL CLASS	B78-13LRC	13"X4.50"	3500lbs. 2-3/8"	5 LUG	4 LEAF	4 POLE RUBBER FLAT
TRLR-70W	2" BALL CLASS 3" ADJUSTABLE	205-14C BIAS (4)	14"X5"	3500lbs. 3"	5 LUG	5 LEAF	4 POLE RUBBER FLAT
TRLR-70X	2" BALL CLASS 3" ADJUSTABLE	205-14C BIAS (4)	14"X5"	3500lbs 3"	5 LUG	5 LEAF	4 POLE RUBBER FLAT
TRLR-70XF	2" BALL CLASS 3" ADJUSTABLE	205-14C BIAS (4)	14"X5"	3500lbs. 3"	5 LUG	5 LEAF	4 POLE RUBBER FLAT
TRLR-100XF	ADJUSTABLE 2-5/6 OPT 3" EYE	205-15C BIAS (4)	14"X5.5"	3500lbs 3"	5 LUG	5 LEAF	4 WIRE LOOM
TRLR-85/125	ADJUSTABLE 2-5/6 OPT 3" EYE	ST225/75R15D RADIAL (4)	14"x6"	(2)-6000lbs	6 LUG	7 LEAF	4 WIRE LOOM
TRLR-150XF	3" BALL EYE	750-16 E BIAS (4)	16"X7"	(2)-6000lbs	8 LUG	7 LEAF	4 WIRE LOOM
TRLR-220XF	3" EYE ADJUSTABLE	ST235/85R16E RADIAL(4)	16"X7"	(2)-7000lbs	8 LUG	Q FLEX	4 WIRE LOOM
TRLR-300XF	3" EYE ADJUSTABLE	ST235/85R16E RADIAL(6)	16"X7"	(2)-6000lbs	8 LUG	Q FLEX	4 WIRE LOOM
TRLR-400XF	3" EYE ADJUSTABLE	ST235/85R16E RADIAL(6)	16"X7"	(3)-7000lbs.	8 LUG	Q FLEX	4 WIRE LOOM
TRLR-600XF	5TH WHEEL	ST215/75R17.5H RADIAL (8)	16"X7"	(3)-10000lbs	8 LUG	7 LEAF	6 WIRE LOOM
TRLR-800AR	5TH WHEEL	ST215/75R17.5H RADIAL (8)	16"X7"	(3)-10000lbs	8 LUG	AIR-RIDE	6 WIRE LOOM

## Brakes

If your trailer has a braking system, the brakes should be inspected the first 200 miles of operation. This will allow the brake shoes and drums to seat properly. After the first 200 mile interval, inspect the brakes every 3,000 miles. If driving over rough terrain, inspect the brakes more frequently.

## Electric Brakes

Electrically actuated brakes (Figure 2) are similar to hydraulic brakes. The basic difference is that hydraulic brakes are actuated by an electromagnet.

Listed below are some of the advantages that electric brakes have over hydraulic brakes:

- Brake system can be manually adjusted to provide the corrected braking capability for varying road and load conditions
- Brake system can be modulated to provide more or less braking force, thus easing the brake load on the towing vehicle
- Brake system has very little lag time between the time the vehicle's brakes are actuated and the trailer's brakes are actuated
- Brake system can provide an independent emergency brake system

Remember in order to properly synchronize the tow vehicle's braking to the trailer's braking, can only be accomplished by road testing. Brake lockup, grabbiness or harshness is due to lack of synchronization between the tow vehicle and the

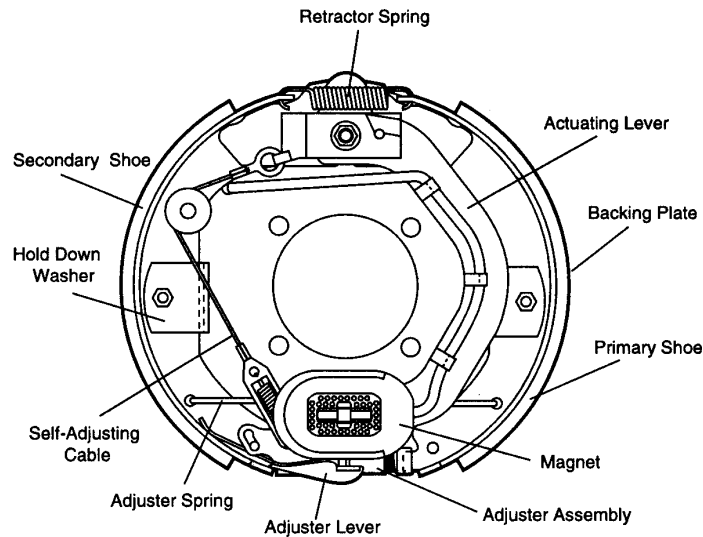
trailer being towed or under-adjusted brakes.

Before any brake synchronizations adjustments can be made, the trailer brakes should be burnished-in by applying the brakes 20-30 times with approximately a 20 m.p.h. decrease in speed, e.g. 40 m.p.h. to 20 m.p.h. Allow ample time for brakes to cool between application. This allows the brake shoes to slightly be seated into the brake drum surface.

Figure 2 displays the major electric brake components that will require inspection and maintenance. Please inspect these components as required.

## Electric Brake Adjustment

1. Place the trailer on jack stands. Make sure the jack stands are placed on secure level ground.
2. Check the wheel and drum for free rotation.
3. Remove the adjusting hole cover from the adjusting slot at the bottom brake backing plate.
4. With a screwdriver or standard adjusting tool, rotate the star wheel of the adjuster assembly to expand the brake shoes.
5. Adjust the brake shoes outward until the pressure of the lining against the wheel drum makes the wheel difficult to turn.
6. Rotate the star wheel in the opposite direction until the wheel rotates freely with slight lining drag.
7. Replace the adjusting hole cover and lower the trailer to the ground.
8. Repeat steps 1 through 6 on the remaining brakes.

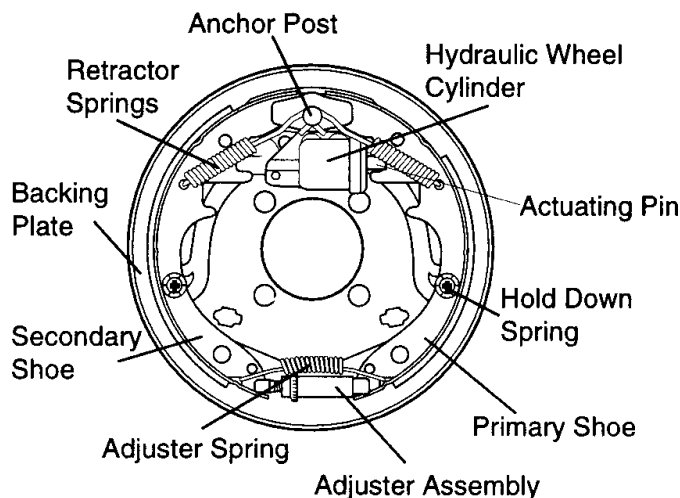


**Figure 2. Electrical Brake Components**

### Hydraulic/Air/Surge Brakes

Hydraulic brakes (Figure 3) should not require any special attention with the exception of routine maintenance such as shoe and lining replacement. These brakes can be adjusted in the same manner as electric brakes. Brake lines should be periodically checked for cracks, kinks, or blockage. Figure 3 below displays the major hydraulic/air/surge brake

components that will require inspection and maintenance. Please inspect these components as required using steps 1 through 6 as referenced in the electric brake adjustments section.



**Figure 3. Hydraulic Brake Components**

## Tires/Wheels/Lug Nuts

Tires and wheels are a very important and critical components of the trailer. When specifying or replacing the trailer wheels it is important the wheels, tires, and axle are properly matched.

### CAUTION:









DO NOT attempt to repair or modify a wheel. DO NOT install in inner tube to correct a leak through the rim. If the rim is cracked, the air pressure in the inner tube may cause pieces of the rim to explode (break off) with great force and cause serious eye or bodily injury.

cause serious eye or bodily injury.

## Tire Wear/Inflation

Tire inflation pressure is the most important factor in tire life. Pressure should be checked cold before operation DO NOT bleed air from tires when they are hot. Check inflation pressure weekly during use to insure the maximum tire life and tread wear.

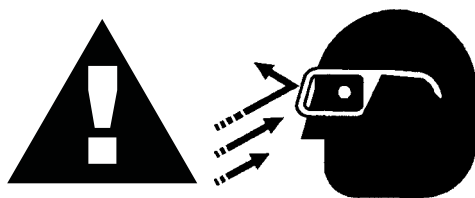
Table 2 (Tire Wear Troubleshooting) will help pinpoint the causes and solutions of tire wear problems.

TABLE 2. TIRE WEAR TROUBLESHOOTING			
WEAR PATTERN	CAUSE	SOLUTION	
	Center Wear	Over Inflation.	Adjust pressure to particular load per tire manufacturer.
	Edge Wear	Under Inflation.	Adjust pressure to particular load per tire manufacturer.
	Side Wear	Loss of chamber or overloading.	Make sure load does not exceed axle rating. Align wheels.
	Toe Wear	Incorrect toe-in.	Align wheels.
	Cupping	Out-of-balance.	Check bearing adjustment and balance tires.
	Flat Spots	Wheel lockup & tire skidding.	Avoid sudden stops when possible and adjust brakes.

## Suspension

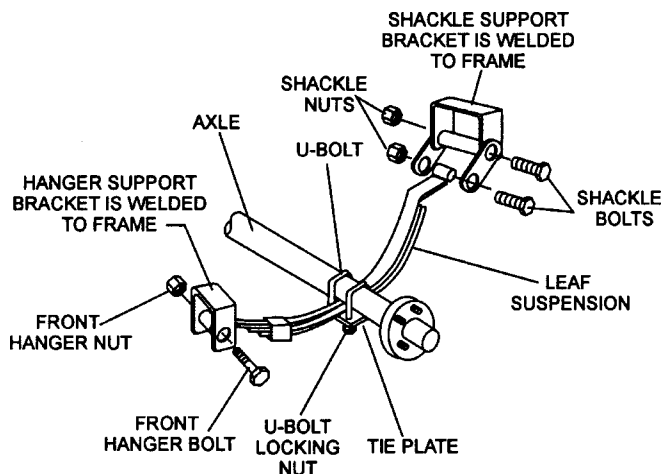
The leaf suspension springs and associated components (Figure 4) should be visually inspected every 6,000 miles for signs of excessive wear, elongation of bolt holes, and loosening of fasteners. Replace all damaged parts (suspension) immediately. Torqued suspension components as detailed in Table 3.

### CAUTION:



#### NOTE

ALWAYS wear safety glasses when removing or installing force fitted parts. Failure to comply may result in serious injury.



**Figure 4. Major Suspension Components**



**Table 3. Suspension Torque Requirements**

Item	Torque (Ft.-Lbs.)
3/8" U-BOLT	MIN-30 MAX-35
7/16" U-BOLT	MIN-45 MAX-60
1/2" U-BOLT	MIN-45 MAX-60
SHACKLE BOLT SPRING EYE BOLT	SNUG FIT ONLY. PARTS MUST ROTATE FREELY. LOCKING NUTS OR COTTER PINS ARE PROVIDED TO RETAIN NUT-BOLT ASSEMBLY.
SHOULDER TYPE SHACKLE BOLT	MIN-30 MAX-50

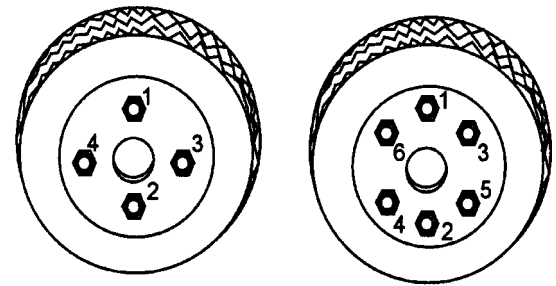
### Lug Nut Torque Requirements

It is extremely important to apply and maintain proper wheel mounting torque on the trailer. Be sure to use only the fasteners matched to the cone angle of the wheel. Proper procedure for attachment of the wheels is as follows:

1. Start all wheel lug nuts by hand.
2. Torque all lug nuts in sequence. See Figure 5. DO NOT torque the wheel lug nuts all the way down. Tighten each lug nut in 3 separate passes as defined by Table 4.
3. After first road use, retorque all lug nuts in sequence. Check all wheel lug nuts periodically.

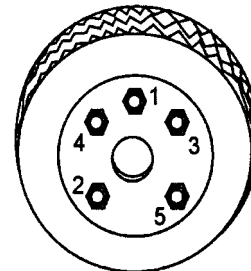
**Table 4. Tire Torque Requirements**

Wheel Size	First Pass FT-LBS	Second Pass FT-LBS	Third Pass FT-LBS
12"	20-25	35-40	50-65
13"	20-25	35-40	50-65
14"	20-25	50-60	90-120
15"	20-25	50-60	90-120
16"	20-25	50-60	90-120

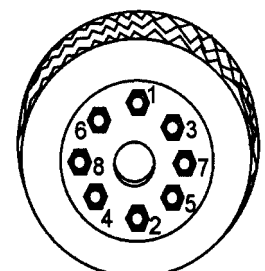


4-LUG NUTS

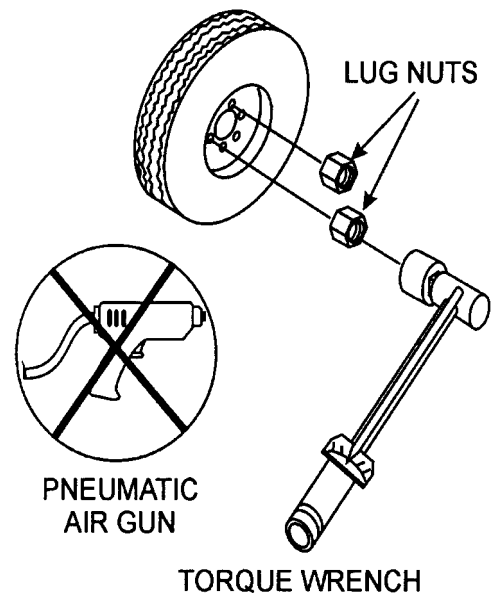
6-LUG NUTS



5-LUG NUTS



8-LUG NUTS

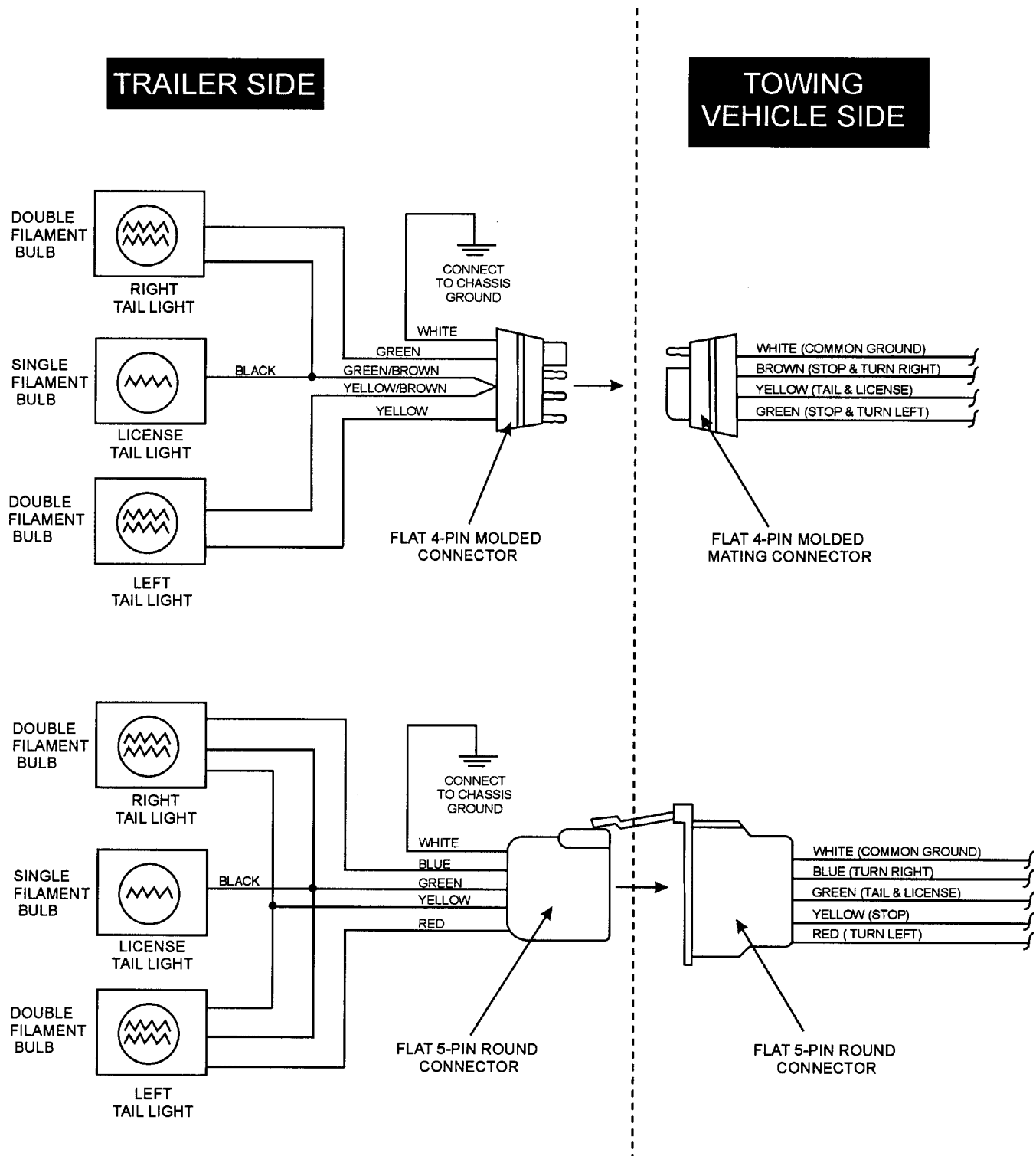


**Figure 5. Wheel Lug Nuts Tightening Sequence**

**NOTE**

NEVER use an pneumatic air gun to tighten wheel lug nuts.

# DCA-400SPK — TRAILER-WIRING DIAGRAM



**NOTE:**  
LIGHTS ARE ORIENTED FROM THE DRIVER'S SEAT

**Table 5. Electric Brake Troubleshooting**

Symptom	Possible Cause	Solution
No Brakes or Intermittent Brakes	Any open circuits or broken wires?	Find and correct.
	Any short circuits?	Find and correct.
	Faulty controller?	Test and correct.
	Any loose connections?	Find and repair.
	Ground wire secure?	Find and secure.
Weak Brakes or Brakes Pull to One Side	Grease or oil on magnets or linings?	Clean or replace.
	Connections corroded?	Clean and correct cause of corrosion.
	Brake drums scored or grooved?	Machine or replace.
	Brakes synchronized?	Correct.
Locking Brakes	Brake components loose, bent or broken?	Replace components.
	Brake drums out-of-round?	Replace.
Noisy Brakes	System lubricated?	Lubricate.
	Brake components correct?	Replace and correct.
Dragging Brakes	Bearings of the wheel adjusted?	Adjust.

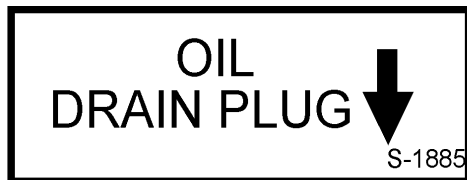
**Table 6. Hydraulic Brake Troubleshooting**

Symptom	Possible Cause	Solution
No Brakes	Brake line broken or kinked?	Repair or replace.
Weak Brakes or Brakes Pull to One Side	Brake lining glazed?	Reburnish or replace.
	Trailer overloaded?	Correct weight.
	Brake drums scored or grooved?	Machine or replace.
	Tire pressure correct?	Inflate all tires equally.
	Tires unmatched on the same axle?	Match tires.
Locking Brakes	Brake components loose, bent or broken?	Replace components.
	Brake drums out-of-round?	Replace.
Noisy Brakes	System lubricated?	Lubricate.
	Brake components correct?	Replace and correct.
Dragging Brakes	Brake lining thickness correct or in right wrong position?	Install new shoes and linings.
	Enough brake fluid or correct fluid?	Replace rubber parts fill with dot4 fluid.

# DCA-400SPK — OPERATION AND SAFETY DECALS

## Machine Safety Decals

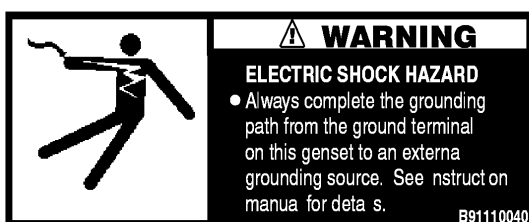
The DCA-400SPK generator is equipped with a number of safety decals. These decals are provided for operator safety and maintenance information. The illustration below and on the preceding pages shows the decals as they appear on the machine. Should any of these decals become unreadable, replacements can be obtained from your dealer.



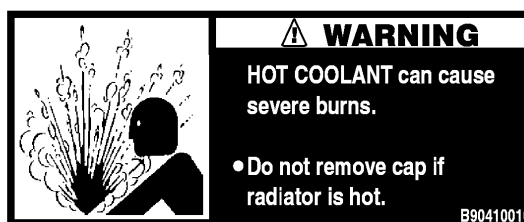
P/N 63606 20204



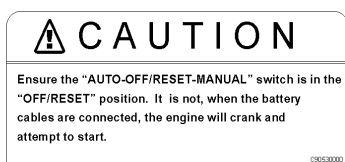
P/N C0551000704



P/N B9511100404



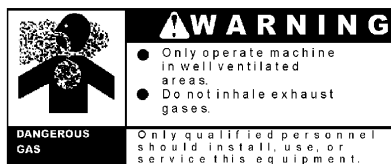
P/N B9504100104



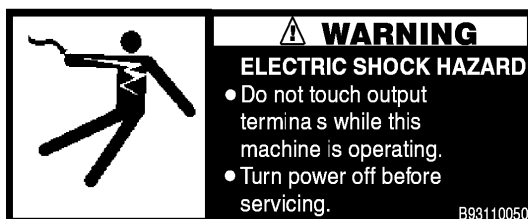
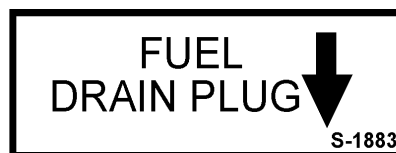
P/N C9505300004



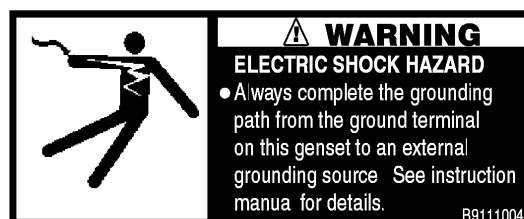
P/N 08040619904



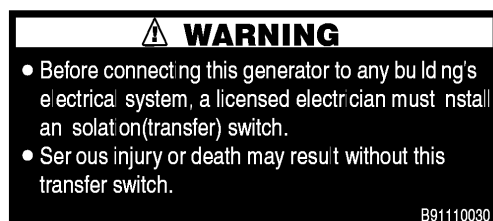
P/N B950420004



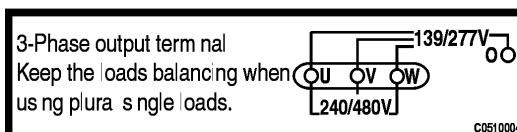
P/N B9531100504



P/N B9511100404



P/N B9511100304



P/N C0551000404

# DCA-400SPK — OPERATION AND SAFETY DECALS

## HANDLING PROCEDURES

1. CHECK TO OPERATING  
Prior to operating the engine, be sure to check the following items to prevent trouble and accidents:
  - (1) Check lubricating oil, cooling water and diesel fuel.
  - (2) Check the tension of the fan belt and charging generator driving belt.
  - (3) Check the CIRCUIT BREAKER is turned "OFF".
  - (4) Set the voltage change-over board to the rated voltage (on y Dual voltage type).
2. STARTING AND OPERATING
  - (1) Turn the battery switch to "ON" position.
  - (2) Turn the STARTER SWITCH to "PREHEAT" position for 10 - 30 seconds.  
Press the STARTER SWITCH to "START" POSITION to start the engine.  
When the engine starts, release the STARTER SWITCH.
  - (3) Warm-up the engine for about 5 minutes.
  - (4) Rotate the THROTTLE HANDLE to "HIGH SPEED" and adjust the engine speed according to the following table.
3. OPERATING PRECAUTIONS
  - (1) When operating, do not turn the BATTERY SWITCH "OFF" to protect the charging generator and engine circuit against damage.
  - (2) When the CIRCUIT BREAKER is tripped "OFF" for over current or short-circuit, check the trouble cause and repair defective parts.  
The CIRCUIT-BREAKER cannot be reset unless it is once turned "OFF" and next turned "ON".
4. STOPPING THE ENGINE
  - (1) Turn the Circuit Breaker to "OFF".  
Rotate the THROTTLE HANDLE TO THE "Low Speed" side.  
Cool down the engine for about 5 minutes.
  - (2) Depress the STOP BUTTON.  
After the engine stops completely, turn "OFF" STARTER SWITCH and BATTERY SWITCH.

	No-load operating speed
50 Hz operation	Approx. 62.5 Hz (1575 rpm)
60 Hz operation	Approx. 62.5 Hz (1575 rpm)

C15200040

P/N C1552000403

## SAFETY INSTRUCTIONS

Improper operation of this machine can cause severe injury or death.

- Read the instruction manual carefully before operating or servicing.
- This machine should only be operated by a person with sufficient knowledge and skill to ensure safe operation.

High voltage circuits are located inside the output terminal cover and control panel.

- Close the cover and control panel before operating.

Moving parts and hot surfaces are contained within the enclosure.

- Close all doors and lock them before operating.

C251 00000

P/N C2551000004



### WARNING

**HOT PARTS** can burn skin.

- Do not touch until the machine has sufficiently cooled.

B90400030

P/N B9504000304



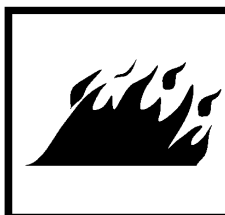
### WARNING

**ELECTRIC SHOCK HAZARD**

- Do not touch internal wiring or connections while this machine is operating.
- Turn power off before servicing.

B93110060

P/N B9531100604



### WARNING

**DIESEL FUEL** can cause fire or explosion.

- Stop engine before fueling.
- Keep cigarettes, sparks and flame away.

B90450000

P/N B9504500004

**CIRCUIT BREAKER**

S-3031

P/N 08406 24504

**PILOT LAMP**

S-3033

P/N 0840624704

# WHISPERWATT 400



**MQ POWER CORP.**

**WHISPERWATT 400  
400 KVA AC GENERATOR  
MODEL DCA-400SSK**

C36110110

P/N C3561101103

**WATER • OIL CHECK AND FILL DAILY**

C05100040

P/N C0551000404

**DIESEL FUEL**

S-1756

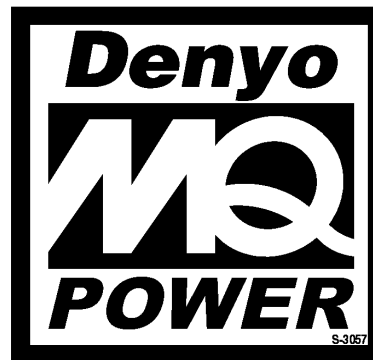
P/N 1320620904

**SUPPORT HOOK**

Never use it for lifting the unit.  
Use the LIFT HOOK on the roof for lifting.

S-2257

P/N 13206 21504



P/N 0840625902

# DCA-400SPK — SPECIFICATIONS

Table 7. Specifications					
Generator Specifications					
Model	DCA-400SPK				
Type	Revolving field, self ventilated, open protected type synchronous generator				
Armature Connection	Star with Neutral				
Phase	3				
Standby Output	440 KVA (352.0 KW)				
Prime Output	400 KVA (320.0 KW)				
Voltage	240V or 480V				
Frequency	60 Hz				
Speed	1800 rpm				
Power Factor	0.8				
Aux. AC Power	Single Phase, 60 Hz				
Voltage	120 V				
Output	4.8 KW (2.4 KW x 2)				
Engine Specifications					
Model	KOMATSU SA6D140-A				
Type	4 Cycle, water-cooled, direct injection, turbo-charged with after-cooler				
No. of Cylinders	6 cylinders				
Bore x Stroke	5.5 in. x 6.5 in. (140 mm x 165mm)				
Rated Output	478 HP/1800 rpm				
Displacement	930 cu. in. (15240 cc)				
Starting	Electric				
Coolant Capacity	16.4 gal. (62 liters)				
Lube Oil Capacity	19.5 gal. (74 liters)				
Fuel Consumption	<table border="1" style="width: 100%; border-collapse: collapse;"> <tr> <td style="text-align: center;">20.4gal. (77.5L)/hr at <b>full load</b></td> <td style="text-align: center;">15.8gal.(59.8L)/hr at <b>3/4 load</b></td> </tr> <tr> <td style="text-align: center;">11.0gal.(41.6L)/hr at <b>1/2 load</b></td> <td style="text-align: center;">6.6gal.(25.0L)/hr at <b>1/4 load</b></td> </tr> </table>	20.4gal. (77.5L)/hr at <b>full load</b>	15.8gal.(59.8L)/hr at <b>3/4 load</b>	11.0gal.(41.6L)/hr at <b>1/2 load</b>	6.6gal.(25.0L)/hr at <b>1/4 load</b>
20.4gal. (77.5L)/hr at <b>full load</b>	15.8gal.(59.8L)/hr at <b>3/4 load</b>				
11.0gal.(41.6L)/hr at <b>1/2 load</b>	6.6gal.(25.0L)/hr at <b>1/4 load</b>				
Battery	12V- 200 AH x 2				
Fuel	#2 Diesel Fuel				

## DCA-400SPK FAMILIARIZATION

### Generator

The MQ Power Model DCA-400SPK is a 320 kW **generator** that is designed as a high quality portable (requires a trailer for transport) power source for telecom sites, lighting facilities, power tools, submersible pumps and other industrial and construction machinery.

### Engine Control Panel

The "Engine Control Panel" is provided with the following:

- Tachometer
- Water Temperature Gauge
- Oil Pressure Gauge
- Charging Ammeter Gauge
- Engine Warning Lamp Module
- Engine Speed Switch
- Pre-Heat Button
- Pre-Heat Lamp
- Emergency Stop Button
- Battery Switch

### Generator Control Panel

The "Generator Control Panel" is provided with the following:

- Output Voltage Adjustment Knob
- Frequency Meter (Hz)
- AC Ammeter (Amps)
- AC Voltmeter (Volts)
- Ammeter Change-Over Switch
- Voltmeter Change-Over Switch
- Panel Light
- Panel Light Switch
- Pilot Lamp

### Output Terminal Panel

The "Output Terminal Panel" is provided with the following:

- Three 240/139V output receptacles, 50 amp
- Two 120V input receptacles, 20 amp
- 3 Load Circuit Breakers 265V @65 amps
- 2 Load GFCI Circuit Breakers 265V@ 20amps

### Control Box

The "Control Box" is provided with the following:

- Main Circuit Breaker 1060 amps
- Over-Current Relay
- High Idle Adjust Trimmer

### Open Delta Excitation System

The DCA-400SPK generator is equipped with the state of the art "**Open-Delta**" excitation system. The open delta system consist of an electrically independent winding wound among stationary windings of the AC output section.

There are four leads: A, B, C and D. During light loads, the power to the **Automatic Voltage Regulator (AVR)** is supplied from the leads parallel connections of B&C. When loads increase, the AVR switches and accepts power from leads A&D. The output of leads A&D increase proportionally with load. This of adding the voltages to each phase provides better voltage response during heavy loads.

The connections of the AVR to the AC output windings are for sensing only. No power is required from these windings.

The open-delta design provides virtually unlimited excitation current, offering maximum motor starting capabilities. The excitation does not have a "**fixed ceiling**" and responds according the demands of the required load.

### Microprocessor Controlled Alarm System

The DCA-400SPK generator is equipped with various alarms and LED status indicators. These alarms and status indicators are provided to add safety to the generator when operating under normal conditions. The DCA-400SPK generator is designed to shutdown in the event of low oil, high coolant temperature, low battery and other operation conditions that may cause severe damage to the generator.



## Engine

The **DCA-400SPK** is powered by a 4 cycle, water cooled, turbocharged KOMATSU Model SA6D140-*Adiesel* engine. This engine is designed to meet every performance requirement for the generator. Reference Table 1, page 16 for engine specifications.

In keeping with Multiquip's policy of constantly improving its products, the specifications quoted herein are subject to change without prior notice.

The basic controls and indicators for the DCA-400SPK generator are addressed on the following pages.

## Mechanical Governor System

The mechanical governor system control the RPM of the engine. When the engine demands increase or decrease, the mechanical governor system regulates the frequency variation to  $\pm 1.5\%$ . The electronic governor option increases frequency variation to  $\pm 0.25\%$ .

## Jacket Water Heater (OPTIONAL)

The jacket water heater is a 1500-watt heater designed to keep the coolant warm in the engine block for fast starts and load acceptance. The heater is thermostatically controlled and once an acceptable engine temperature is achieved it will cycle on and off, operating only about 1/3 of the time, which makes it more efficient than the direct block type heater. It is designed to keep the engine coolant between 100 and 120 degrees Fahrenheit.

Under normal conditions, 20 to 15 minutes is required to raise the engine temperature of a cold engine to 100 degrees Fahrenheit.

## Battery Charger

The battery charger will operate in a 'BOOST' mode until the battery's current acceptance falls to 70% of the charger's rating. The charger will then go into a 'FLOAT' mode, where it discharges a lower voltage until an AC failure, or the battery is discharged.

# DCA-400SPK — MAJOR COMPONENTS

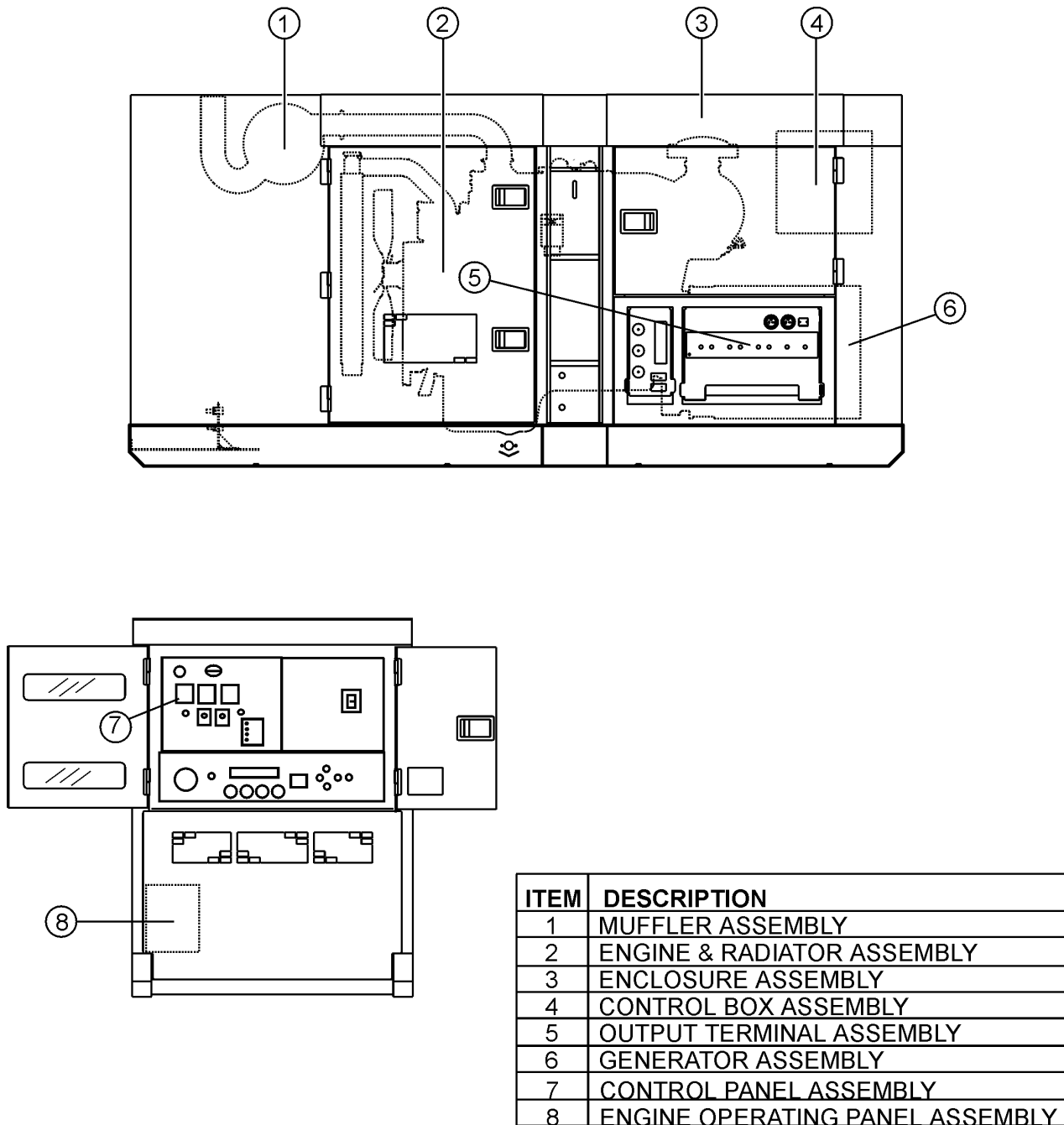
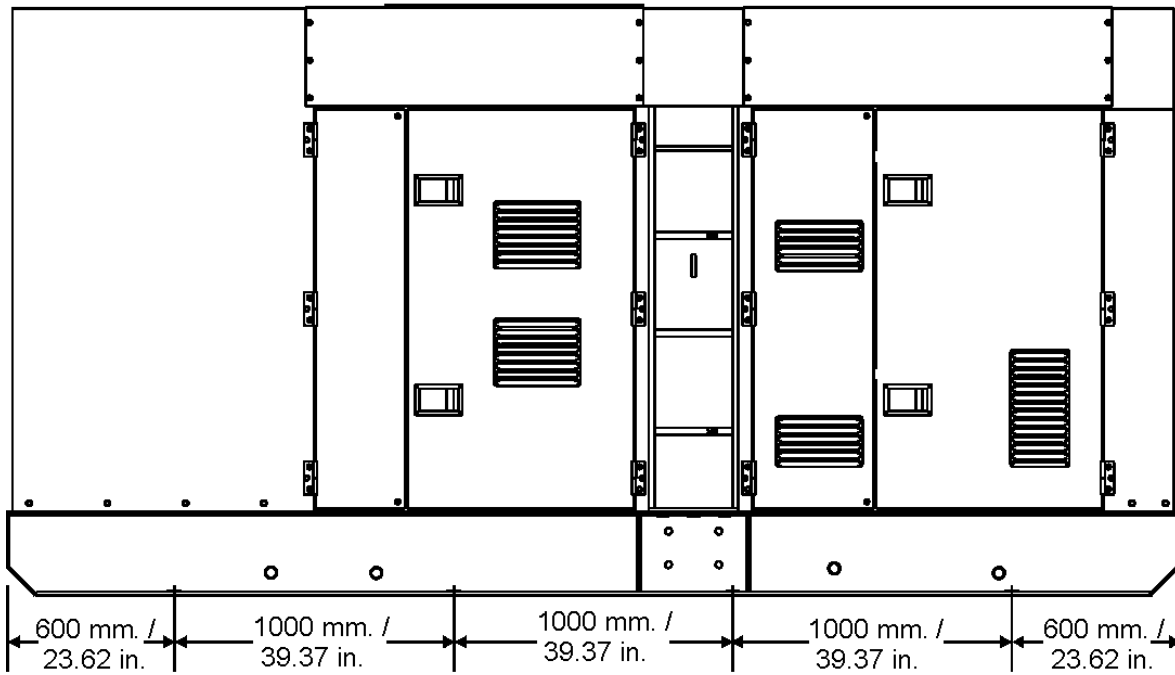


Figure 6. Major Components



# DCA-400SPK — DIMENSIONS (TOP AND SIDE)

## SIDE VIEW



(BOLT HOLE LOCATION)

## TOP VIEW

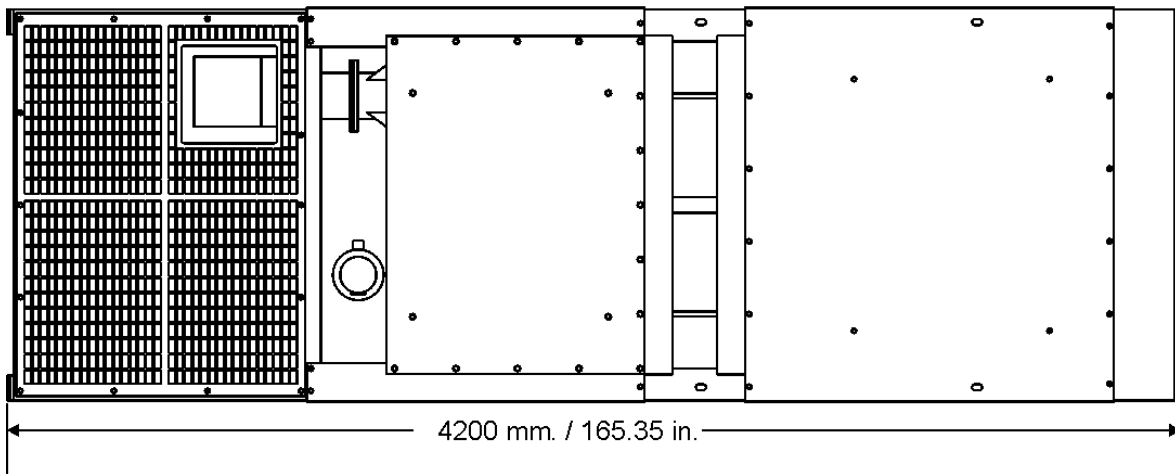
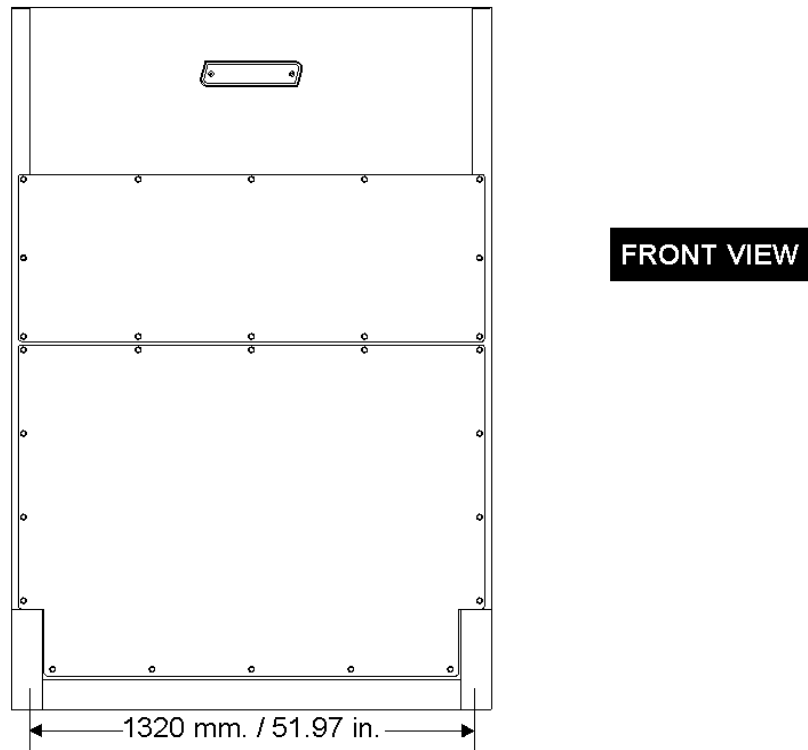
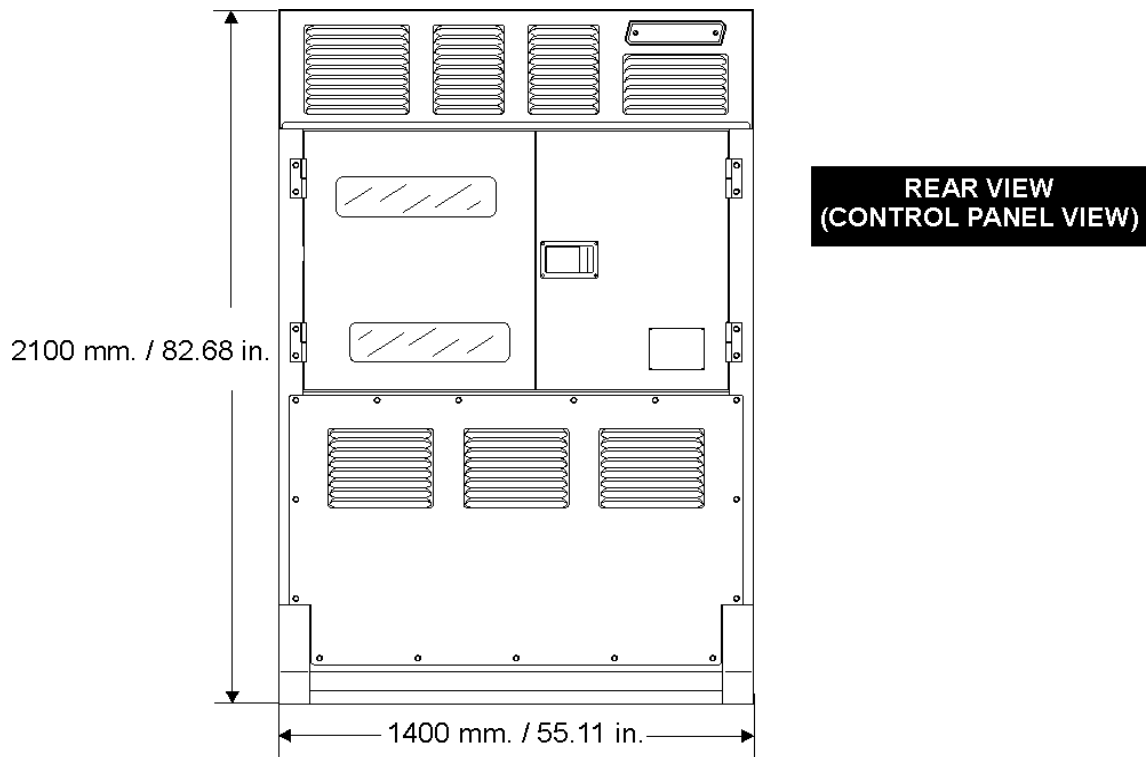
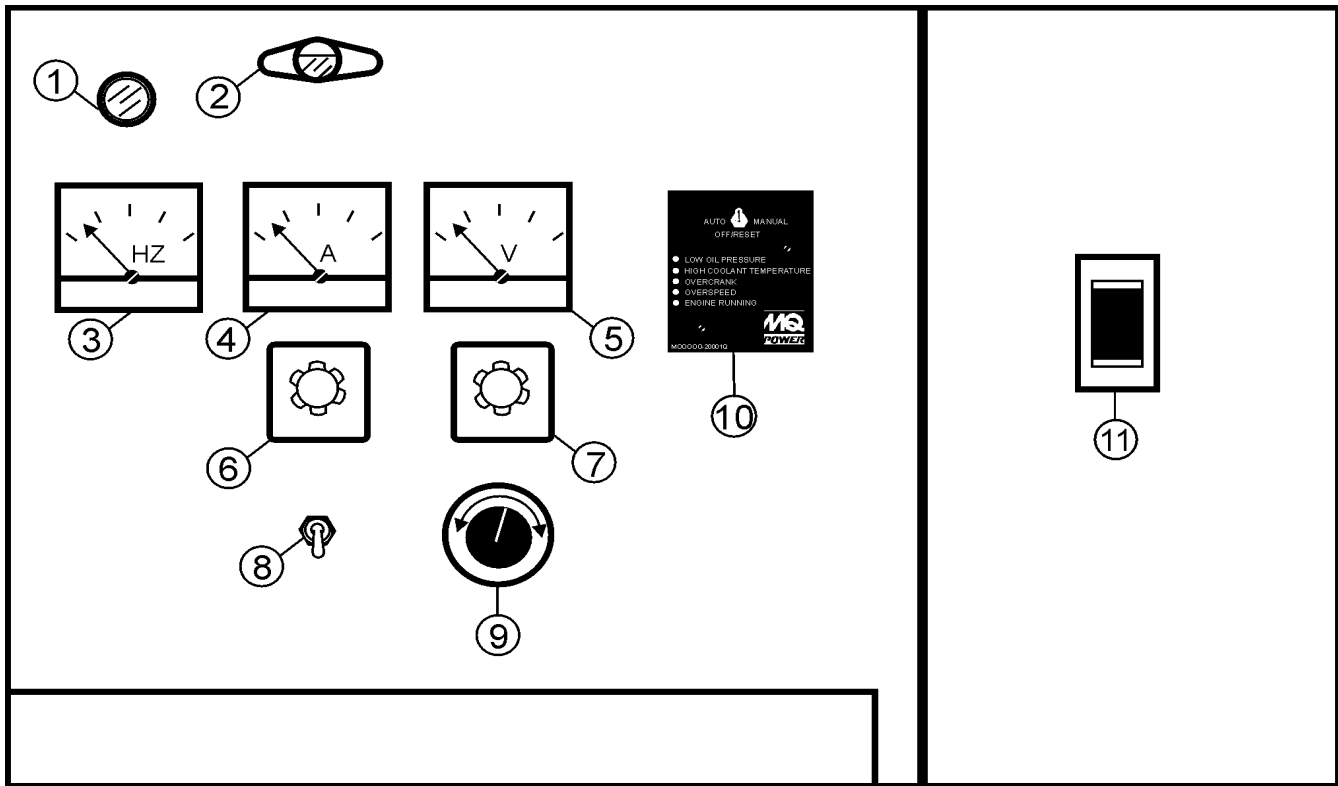


Figure 7a. Dimensions

# DCA-400SPK — DIMENSIONS (FRONT AND REAR)



**Figure 7b. Dimensions**

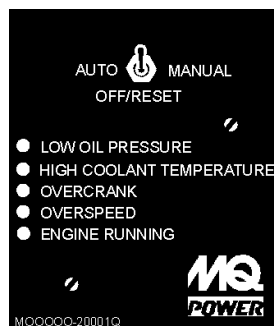


NO.	NAME
1	PILOT LAMP
2	PANEL LIGHT
3	FREQUENCY METER
4	AC AMMETER
5	AC VOLTMETER
6	AMMETER CHANGE OVER SWITCH
7	VOLTMETER CHANGE OVER SWITCH
8	LIGHT PANEL SWITCH
9	VOLTAGE REGULATOR
10	MICROPROCESSOR ENGINE CONTROL (MPEC)
11	CIRCUIT BREAKER

Figure 8. Control Panel

The definitions below describe the controls and functions of the DCA-400SPK " **Control Panel** " (Figure 8).

1. **Pilot Lamp** – Indicates that the generator is working properly.
2. **Panel Light** – Normally used in dark areas or at night time. When activated, panel lights will illuminate. When the generator is not in use be sure to turn the panel light switch to the OFF position.
3. **Frequency Meter** – Indicates the output frequency in hertz (Hz). Normally 60 Hz  $\pm$ 1 Hz .
4. **AC Ammeter** – Indicates the amount of current the load is drawing from the generator.
5. **AC Voltmeter** – Indicates the single phase output voltage present at the UVW terminals.
6. **Ammeter Change-Over Switch** – This switch allows the AC ammeter to indicate the current flowing to the load connected to any phase of the output terminals, or to be switched off.
7. **Voltmeter Change-Over Switch** – This switch allows the AC voltmeter to indicate phase to phase voltage between any two phases of the output terminals or to be switched off.
8. **Panel Light Switch** – When activated will turn on control panel light.
9. **Voltage Regulator Control** – Allows manual adjustment of the generator's output voltage.
10. **MPEC – Microprocessor Engine Control Module – (MPEC)** has a vertical row of status LED's (Figure 9), that when lit, indicate that an engine malfunction (fault), has been detected. When a fault has been detected the MPEC will evaluate the fault and if the fault is major will shutdown the generator.



**Figure 9. MPEC Module**

During *cranking cycle* , The MPEC will attempt to crank the engine for 10 seconds before disengaging.

If the engine does not engage (start) by the third attempt, the engine will be shutdown by the MPEC's " Over Crank Protection" mode. If the engine engages at a speed (RPM's) that is not safe, the MPEC will shutdown the engine by initializing the "Over Speed Protection" mode.

Also the MPEC will shutdown the generator in the event of low oil pressure, high coolant temperature, low coolant level, and loss of magnetic pickup. These conditions can be observed by monitoring the LED status indicators on the front of the MPEC module.

**A. Off/Manual/Auto Switch** – This switch controls the running of the generator. If this switch is left in the "OFF" position, the generator will not run. When this switch is set to the *manual* position, the generator will start immediately.

If the generator is to be connected to a building's AC power source via a transfer switch (isolation), place the switch in the *auto* position. In this position the generator will monitor the AC line output from the building's power source.

**B. Low Oil Pressure** – Indicates the engine pressure has fallen below 15 psi. The oil pressure is detected using variable resistive values from the oil pressure sending unit. This is considered a *major* fault.

**C. High Coolant Temperature** – Indicates the engine temperature has exceeded 215°F. The engine temperature is detected using variable resistive values from the temperature sending unit. This is considered a *major* fault.

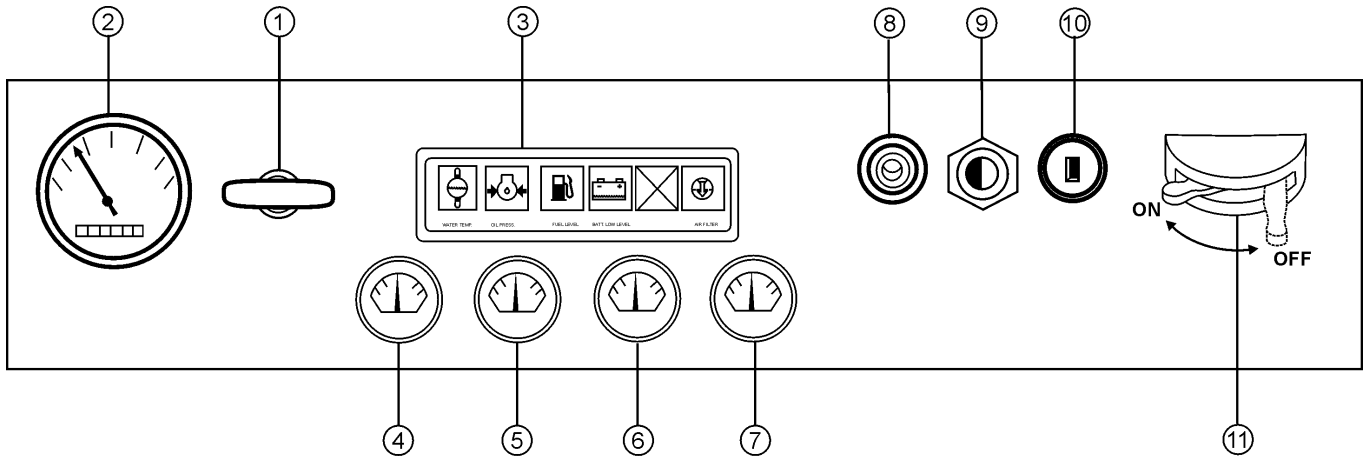
**D. Overcrank Shutdown** – Indicates the unit has attempted to start a pre- programmed number of times, and has failed to start. The number of cycles and duration are programmable. Typical programmable start settings is 3 cycles with a 10 second duration .This is considered a *major* fault.

**E. Overspeed Shutdown** – Indicates the engine is running at an unsafe speed. This is considered a *major* fault.

**F. Engine Running** – Indicates that engine is running at a safe operating speed.

**11. Main Circuit Breaker** – This three-pole, 800 amp main breaker is provided to protect the UVW voltage output terminals from overload.

# DCA-400SPK — ENGINE OPERATING PANEL



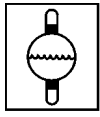
1	THROTTLE HANDLE
2	TACHOMETER
3	ENGINE WARNING DISPLAY LED
4	OIL PRESSURE GAUGE
5	WATER TEMP. GAUGE
6	CHARGING AMMETER
7	FUEL LEVEL GAUGE
8	PREHEAT LAMP
9	EMERGENCY STOP BUTTON
10	STARTER SWITCH
11	BATTERY SWITCH

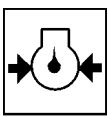
**Figure 10. Engine Operating Panel**





# DCA-400SPK — ENGINE OPERATING PANEL

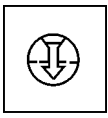
The definitions below describe the controls and functions of the DCA-400SPK " **Engine Operating Panel** "(Figure 10).

1. **Throttle Handle** - This handle controls the speed of the engine (low or high).
2. **Tachometer** – Indicates engine speed in RPM's for 60 Hz operation. This meter should indicate 1800 RPM's when the rated load is applied. In addition a built in hour meter will record the number of operational hours that the generator has been in use.
3. **Engine Warning Display Module** – This module display's the following engine failures:
  - A. **Overheat Lamp** – This lamp goes ON when the cooling water temperature rises abnormally. If the lamp goes ON during normal operation of the generator, the emergency shutdown device will stop the engine automatically.
 

WATER TEMP.
  - B. **Low Oil Pressure Lamp** – During normal operation of the generator this lamp should remain OFF. When the Auto-OFF/Reset-Manual switch is set to the "Manual" position to start the engine, the lamp will be lit. After the oil pressure rises after start-up the lamp will go OFF. If this lamp is ever lit (ON) during normal operation of the generator, the emergency shutdown device will stop the engine automatically.
 


OIL PRESS.
  - C. **Low Fuel Level Lamp** – When this lamp is ON, it is time to stop the engine and add fuel. Remember to let the engine cool before adding fuel.
 


FUEL LEVEL
  - D. **Low Battery Fluid Lamp** – This lamp goes ON when the battery fluid is low. If this lamp goes ON during normal operation of the generator, stop the engine and fill the battery with distilled water to the specified level.
 

BATT. LOW LEVEL
  - E. **Clogged Air Filter Lamp** – This lamp goes ON when the air filter is clogged. If this lamp goes ON during normal operation of the generator, stop the engine and replace the air filter.
 

AIR FILTER

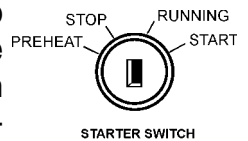
4. **Oil Pressure Gauge** – During normal operation this gauge be should read in the "GREEN" zone. When starting the generator the oil pressure mar read a little bit higher, but after the engine warms up the oil pressure should return to the green zone.
5. **Water Temperature Gauge** – During normal operation this gauge be should read in the "GREEN" zone.
6. **Charging Ammeter Gauge** – Indicates the current being supplied by the engine's alternator which provides current for generator's control circuits and battery charging system.
7. **Fuel Gauge** - Indicates amount of diesel fuel available.

8. **Pre-Heat Lamp** – Indicates that the glow plugs of the diesel engine are hot and the engine is ready to be started.
 

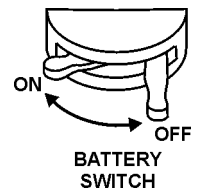
PRE-HEAT LAMP
9. **Emergency Stop Button** – Push this button inward to stop the engine in the event of an emergency. **DO NOT** use this button as a means of stopping the engine.
 

EMERGENCY STOP BUTTON

10. **Starter Switch** – Use this switch to preheat the engine and turn on the generator (This feature will not be on the unit if it is equipped with a MPEC-see Control Panel).



11. **Battery Switch** – This switch should be set to the ON position during normal operation. When the engine has been stop, place this switch in the OFF position. **DO NOT** turn this switch during normal operation, it could cause damage to the electrical equipment



# DCA-400SPK — OUTPUT TERMINAL PANEL OVERVIEW

## OUTPUT TERMINAL FAMILIARIZATION

The "Output Terminal Panel" is provided with the following:

- Two 120V GFCI receptacles, 20 amp
- Three 240/139V output receptacles, 50 amp
- Two 120V input receptacles, 20 amp (optional)
- 3 Load Circuit Breakers 265V @65 amps
- 2 Load GFCI Circuit Breakers 265V @ 20amps

## Control Box

The "Control Box" is provided with the following:

- Main Circuit Breaker 1000 amps
- Over-Current Relay

## Output Terminal Panel

The Output Control Panel (See Figure 14) is located on the right hand side (left from control panel) of the generator. The UVWO lugs are protected by a face plate cover that can be secured in the close position by a pad lock. (See Figure 11).

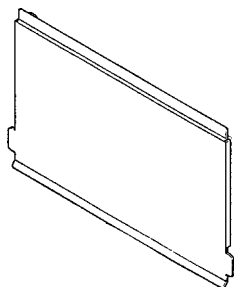


FIGURE 11. Output Terminal Cover

## 120 Volt Recetacle

Two GFCI Duplex Nema 5-20R (120V, 20 Amp) receptacle is provided on the output terminal. This receptacle can be used anytime the generator is in operation. The receptacle is controlled by the circuit breaker located on the control panel.

Pressing the reset button resets the receptacle after being tripped. Pressing the "Test Button" (See Figure 12) in the center of this receptacle will check the GFCI function. The receptacle should be tested at least once a month.

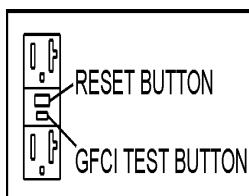


FIGURE 12. GFCI Test Button

## Connecting Load

Loads can be connected to the generator by the UVWO Lugs or the convenience receptacles. (See figure 13). Make sure to read the operation manual before attempting to connect a load to the generator.

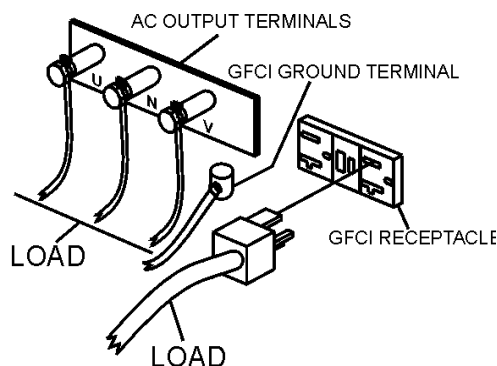


FIGURE 13. Connecting Load

## Circuit Breakers

To protect the generator from an overload, a 3-pole, 1000 amp, **main** circuit breaker is provided to protect the UVW output terminals from overload. In addition two single-pole, 20 amp **GFCI** circuit breakers are provided to protect the GFCI receptacles from overload. Three 50 amp **load** circuit breakers have also been provided to protect the load side of the generator from overload. Make sure to switch **ALL** circuit breakers to the "OFF" position prior to starting the engine.

## Maximum Output

The entire load connected to the UVWO Lugs, all four slots in the duplex receptacles, and the must not exceed 352 kW in standby or 320 in prime output.

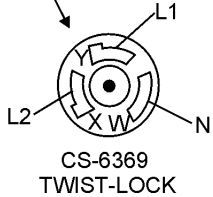
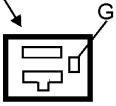
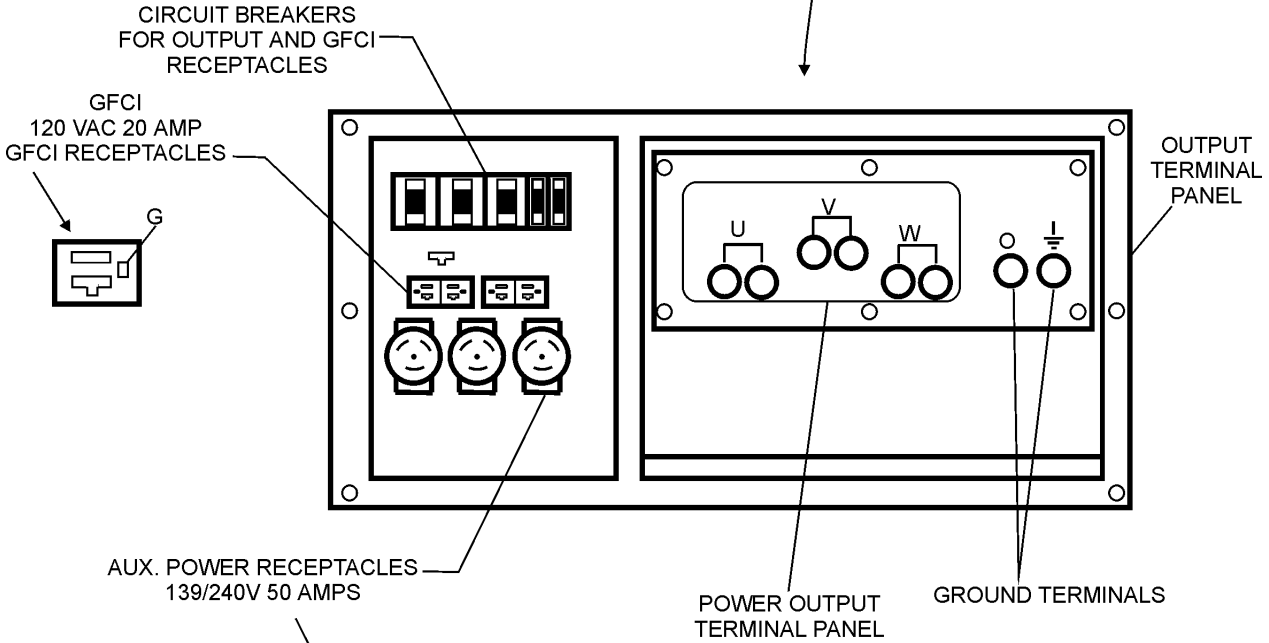
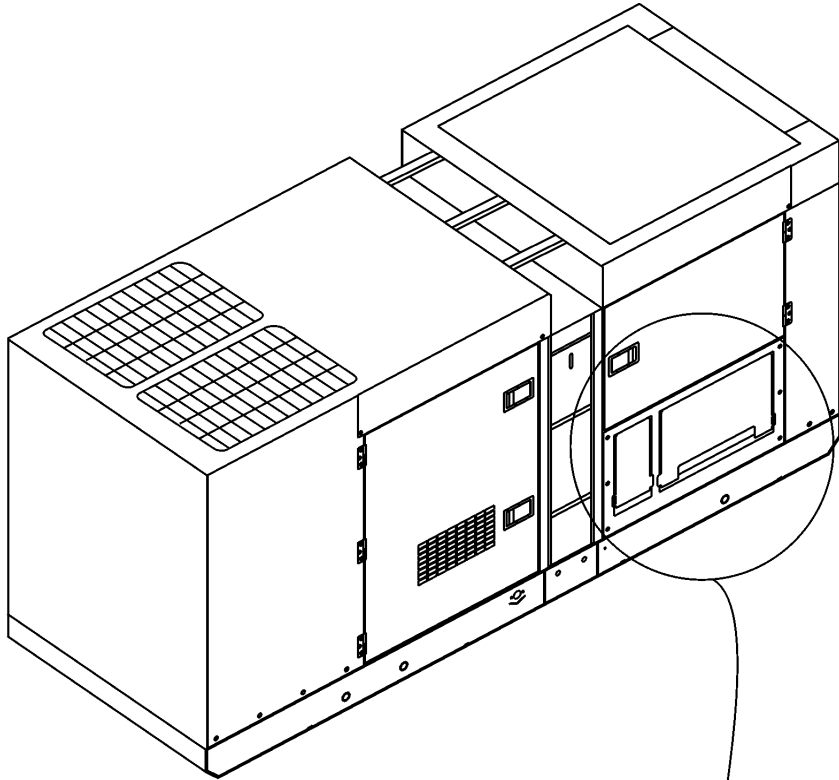
## Twist Lock Dual Voltage Receptacles

Three CS-6369 auxiliary power receptacles have been provided to supply 208/120V. The voltage regulator knob on the control panel may need to be used to adjust the voltage to 208 or 416V.

## Input Receptacles

Two 120 volt, 20 amp input receptacles are provided to supply power to accessories, such as the battery charger (optional) or jacket water heater (optional).

# DCA-400SPK — OUTPUT TERMINAL PANEL OVERVIEW



**FIGURE 14. Output Terminal Panel**

**NOTE**

Legs O and Ground are considered Bonded Grounds.

# DCA-400SPK — OUTPUT TERMINAL PANEL OVERVIEW

## Output Terminal Panel Available Voltages

A wide range of voltages are available to supply load to many different applications. Voltages may be selected by using the voltage change-over board and how you hookup your hard wire connection to the generator. To obtain some of the voltages listed, fine adjustment with the Voltage Regulator on the control panel is necessary. See the table below (Table 8) for a list of available voltages the generator is able to supply.

TABLE 8. VOLTAGES AVAILABLE						
MODEL	DCA400SSK					
3 PHASE VOLTAGE (RECONNECTABLE)	208 VOLT	220 VOLT	240 VOLT	416 VOLT	440 VOLT	480 VOLT
SINGLE PHASE (ADJUSTABLE)	120 VOLT	127 VOLT	139 VOLT	240 VOLT	254 VOLT	277 VOLT

## CAUTION :



**NEVER** attempt to change the Voltage Change-over board while the engine is engaged.

## Over Current Relay

An over current relay is connected to the circuit breaker. In an over current situation, both the circuit breaker and the over current relay may trip. If the circuit breaker can not be reset, the reset button on the over current relay must be pressed. The over current relay is located in the control box.

## Maximum Amps

The following table show the maximum amps the entire generator can provide. Do not exceed the maximum amps listed. (See Table 9)

**Table 9. Maximum Amps**

Model:	DCA400SPK
Rated Voltage	Maximum Amps
Single Phase 120 Volt	888.9 amps (4 wire)
Single Phase 240 Volt	444.4 amps (4 wire)
Three Phase 240 Volt	962.3 amps
Three Phase 480 Volt	481.1 amps

# DCA-400SPK — OUTPUT TERMINAL PANEL OVERVIEW

## How to read the output terminal gauges.

The gauges and knobs on the control panel **DO NOT** effect the generator output in any fashion. They are there to simply help the operator observe how much power is being supplied produced at the UVWO legs.

To read the output of the W-U legs, for example, place the AC Voltmeter Change-over switch to the W-U position and the AC ammeter Change -over Switch to the U or W position to read the output on the selected leg.

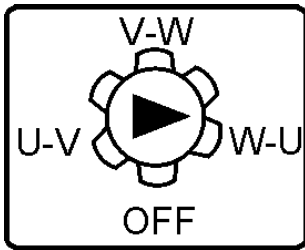


FIGURE 15. AC Voltmeter Change-over switch (Reading the W-U leg on the output terminal panel)

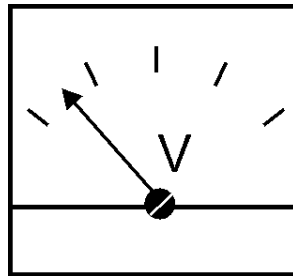


FIGURE 16. AC Voltmeter Gauge (Volt reading on W-U Lug)

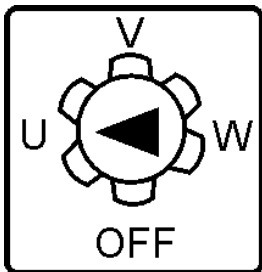


FIGURE 17. AC Ammeter Change-over Switch (Reading the U leg on the output terminal panel)

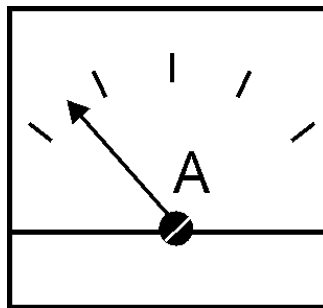


FIGURE 18. AC Ammeter (Amp reading on U lug)

# DCA-400SPK — OUTPUT TERMINAL PANEL OVERVIEW

## Voltage Change-over Board

The voltage change-over board changes the available voltages of the output terminal panel UVWO lugs. The voltage change-over board is located on the control box behind the control panel. There are six (6) plates that can be set into two set positions to get six different voltages. Unless specified differently, the generator comes from the factory in the 240V position.

### 240 Volt Set position

The voltage change-over board 240V set position uses all 6 plates in 6 different connection places. See figure 19 below.

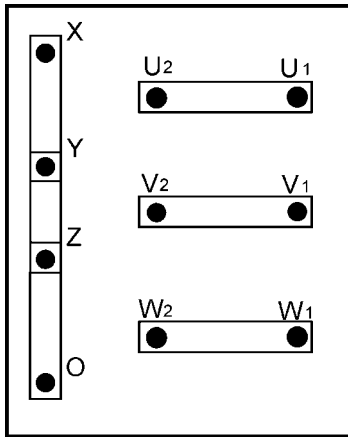


FIGURE 19. Voltage Change-over Board 240V set position.

### 3 Phase, 240 Volt

The following connection, with the voltage change-over board set into the 240V set position (See Figure 19), can offer **THREE PHASE** power at 240V. After hooking up the hard wires to the lugs as shown in figure 20 below, 240V will be the voltage output.

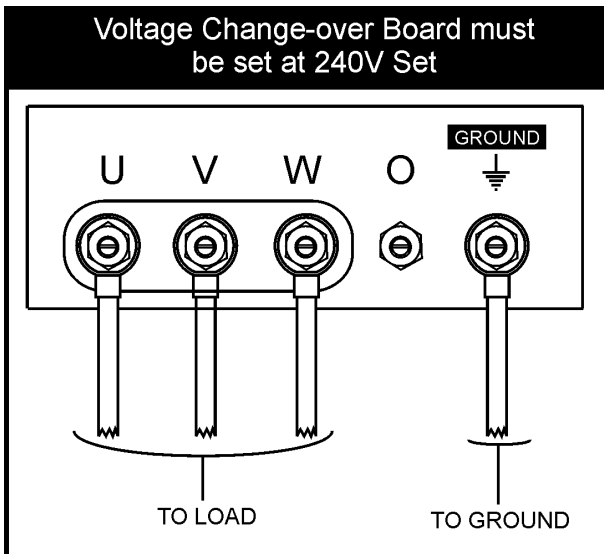


FIGURE 20. Hard Wire Hookup for Three Phase 240V

### Single Phase, 240 Volt

The following connection, with the voltage change-over board set into the 240V set position (See Figure 19), can offer **SINGLE PHASE** power at 240V. After hooking up the hard wires to the lugs as shown in figure 21 below, 240V will be the voltage output.

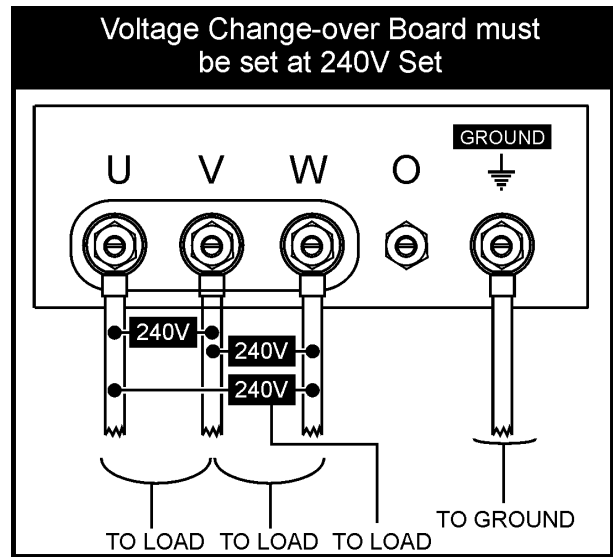


FIGURE 21. Hard Wire Hookup for Single Phase 240V

### Single Phase, 139 Volt

The following connection, with the voltage change-over board set into the 240V set position (See Figure 19), can offer **SINGLE PHASE** power at 139V. After hooking up the hard wires to the lugs as shown in figure 22 below, 139V will be the voltage output.

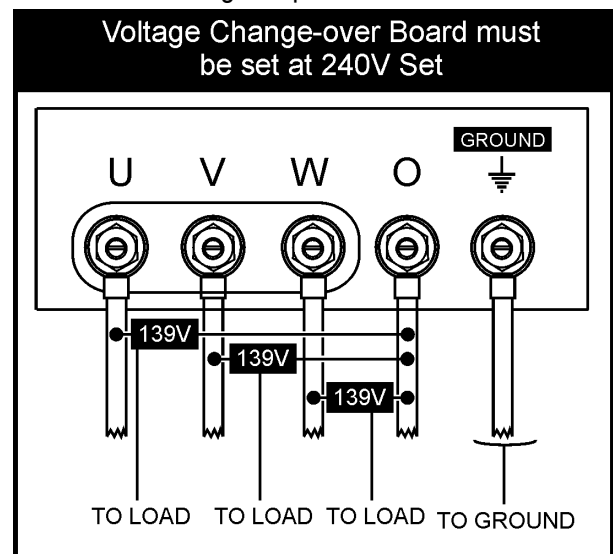


FIGURE 22. Hard Wire Hookup for Single Phase 139V

# DCA-400SPK — OUTPUT TERMINAL PANEL OVERVIEW

## 480 Volt Set position

The voltage change-over board 480V set position uses all 6 plates in 3 different connection places. There are 2 plates at every position (Every plate is used). See figure 23 below.

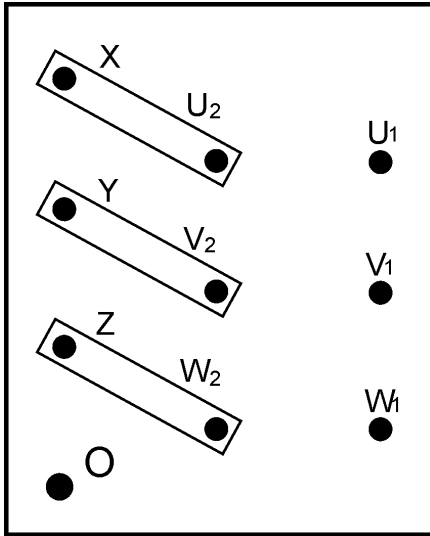


FIGURE 23. Voltage Change-over Board 480V set position.

## 3 Phase, 480 Volt

The following connection, with the voltage change-over board set into the 480V set position (See Figure 23), can offer **THREE PHASE** power at 480V. After hooking up the hard wires to the lugs as shown in figure 24 below, 480V will be the voltage output.

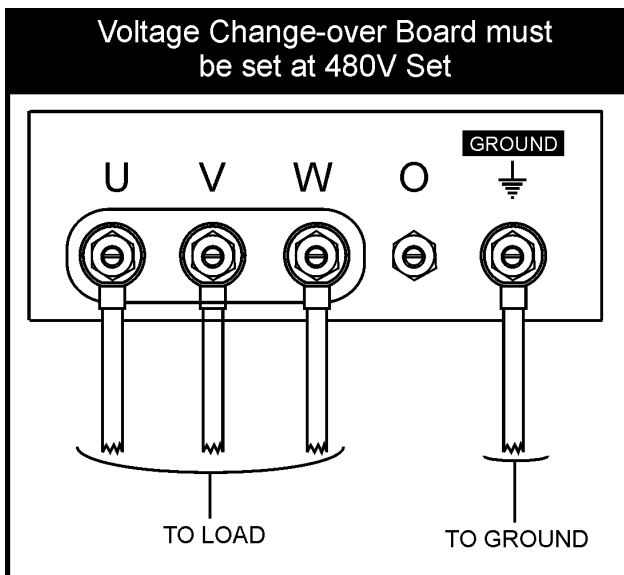


FIGURE 24. Hard Wire Hookup for Three Phase 480V

## Single Phase, 480 Volt

The following connection, with the voltage change-over board set into the 480V set position (See Figure 23), can offer **SINGLE PHASE** power at 480V. After hooking up the hard wires to the lugs as shown in figure 25 below, 480V will be the voltage output.

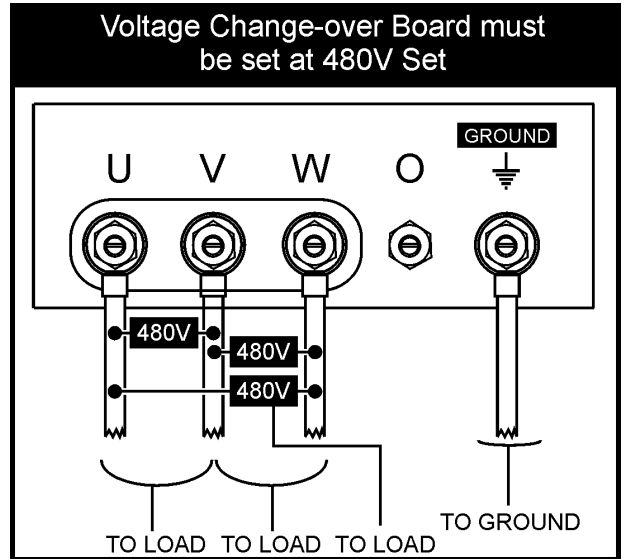


FIGURE 25. Hard Wire Hookup for Single Phase 480V

## Single Phase, 277 Volt

The following connection, with the voltage change-over board set into the 480V set position (See Figure 23), can offer **SINGLE PHASE** power at 277V. After hooking up the hard wires to the lugs as shown in figure 26 below, 277V will be the voltage output.

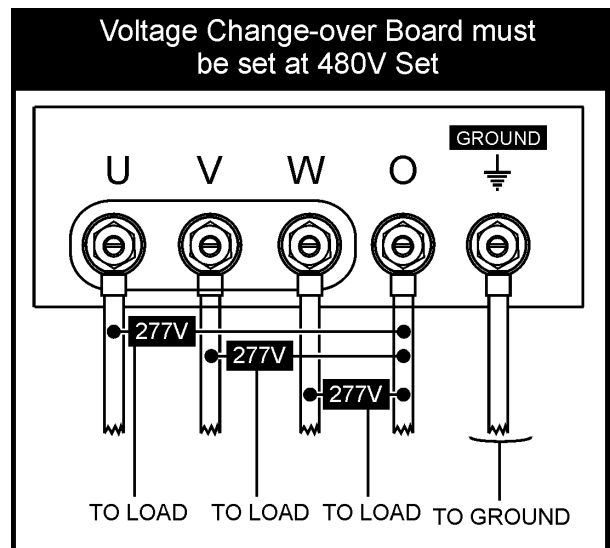


FIGURE 26. Hard Wire Hookup for Single Phase 277V

## Outdoor Installation

Install the generator in a location where it will not be exposed to rain or sunshine. Make sure the generator is on secure level ground so that it cannot slide or shift around. Also install the generator in a manner so that the exhaust will not be discharged in the direction of nearby homes.

The installation site must be relatively free from moisture and dust. All electrical equipment should be protected from excessive moisture. Failure to do will result in deterioration of the insulation and will result in short circuits and grounding.

Foreign materials such as dust, sand, lint and abrasive materials have a tendency to cause excessive wear to engine and alternator parts.



## CAUTION :

Pay close attention to ventilation when operating the generator inside tunnels and caves. The engine exhaust contains noxious elements. Engine exhaust must be routed to a ventilated area.

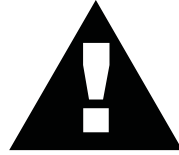
## Indoor Installation

Exhaust gases from diesel engines are extremely poisonous. Whenever an engine is installed indoors the exhaust fumes must be vented to the outside. The engine should be installed at least two feet from any outside wall. Using an exhaust pipe which is too long or too small can cause excessive back pressure which will cause the engine to heat excessively and possibly burn the valves.

## Mounting

The generator must be mounted on a solid foundation (such as concrete) and set firmly on the foundation to isolate vibration of the generator when it is running. The generator must set at least 6 inches above the floor or grade level (in accordance to NFPA 110, Chapter 5-4.1). DO NOT remove the metal skids on the bottom of the generator. They are to resist damage to the bottom of the generator and to maintain alignment.

## CAUTION :



An electric shock may happen when vibrators are used. Pay close attention to handling when operating vibrators and always use rubber boots and gloves to insulate the body from electrical shock.

## Generator Grounding

To guard against electrical shock and possible damage to the equipment, it is important to provide a good **EARTH** ground.

Article 250 (Grounding) of the National Electrical Code (NEC) provides guide lines for proper grounding and specifies that the cable ground shall be connected to the grounding system of the building as close to the point of cable entry as practical.

NEC articles 250-64(b) and 250-66 set the following grounding requirements:

1. Use one of the following wire types to connect the generator to earth ground.
  - a. Copper - 10 AWG (5.3 mm<sup>2</sup>) or larger.
  - b. Aluminum - 8 AWG (8.4 mm<sup>2</sup>) or larger.
2. When grounding the generator (Figure 27) connect the ground cable between the lock washer and the nut on the generator and tighten the nut fully. Connect the other end of the ground cable to earth ground.
3. NEC article 250-52(c) specifies that the earth ground rod should be buried a minimum of 8 ft. into the ground.

## NOTE

When connecting the generator to any buildings electrical system **ALWAYS** consult with a licensed electrician.



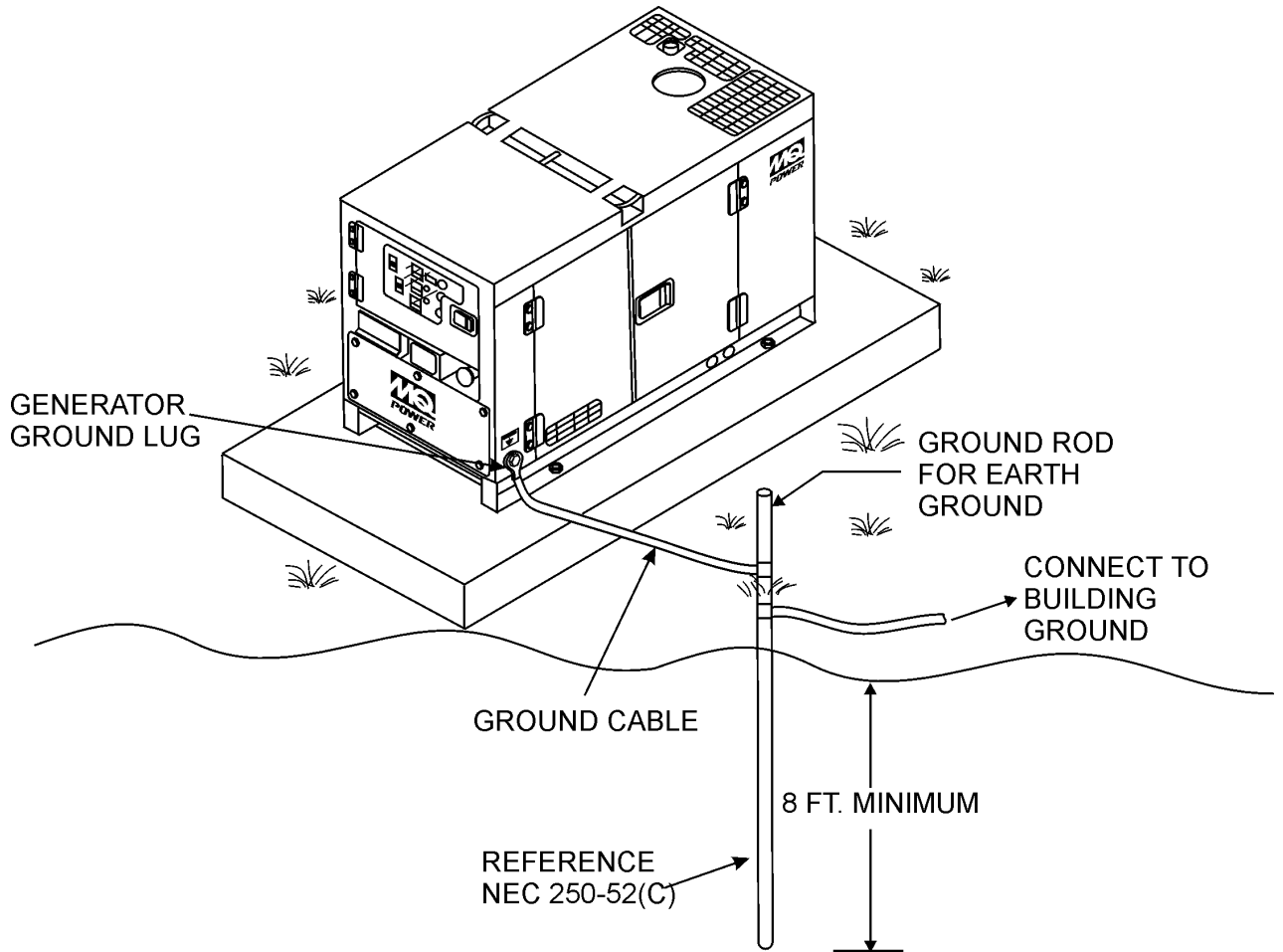


Figure 27. Typical Generator Grounding Application

## General Inspection Prior to Operation

The DCA-400SPK generator has been thoroughly inspected and accepted prior to shipment from the factory. However, be sure to check for damaged parts or components, or loose nuts and bolts, which could have occurred in transit.

## Extension Cable

When electric power is to be provided to various tools or loads at some distance from the generator, extension cords are normally used. Cables should be sized to allow for distance in length and amperage so that the voltage drop between the generator and point of use (load) is held to a minimum. Use the Cable Selection Guide (Table 10) as a guide for selecting proper cable size.

## Circuit Breakers

To protect the generator from an overload, a 3-pole, 1060 amp, **main** circuit breaker is provided to protect the UVW output terminals from overload. In addition two single-pole, 20 amp **GFCI** circuit breakers are provided to protect the GFCI receptacles from overload. Three 50 amp **load** circuit breakers have also been provided to protect the load side of the generator from overload. Make sure to switch **ALL** circuit breakers to the "OFF" position prior to starting the engine.

### NOTE

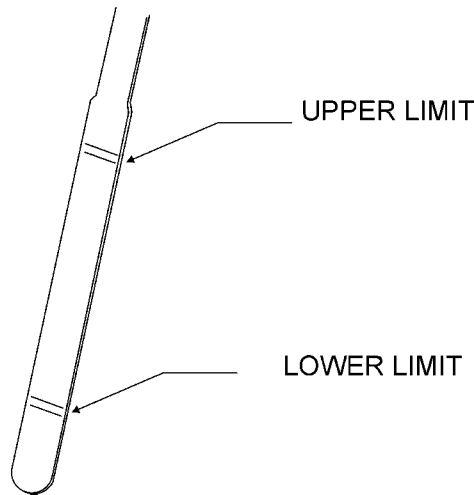
**ALWAYS** consult with a licensed electrician for correct extension cord wire size.

**Table 10. Cable Selection (60 Hz, Single Phase Operation)**

Current in Amperes	Load In Watts		Maximum Allowable Cable Length			
	At 120 Volts	At 240 Volts	#10 Wire	#12 Wire	#14 Wire	#16 Wire
2.5	300	600	1000 ft.	600 ft.	375 ft.	250 ft.
5	600	1200	500 ft.	300 ft.	200 ft.	125 ft.
7.5	900	1800	350 ft.	200 ft.	125 ft.	100 ft.
10	1200	2400	250 ft.	150 ft.	100 ft.	
15	1800	3600	150 ft.	100 ft.	65 ft.	
20	2400	4800	125 ft.	75 ft.	50 ft.	
CAUTION: Equipment damage can result from low voltage.						

## Lubrication Oil

Fill the engine crankcase with lubricating oil through the filler hole, but do not overfill. Make sure the generator is level. With the dipstick inserted all the way, but without being screw into the filler hole, verify that the oil level is maintained between the two notches (Figure 28) on the dipstick. See Table 9 for proper selection of engine oil.



**Figure 28. Engine Oil Dipstick**

When checking the engine oil, be sure to check if the oil is clean and viscous. If the oil is not clean, drain the oil by removing the oil drain plug, and refill with the specified amount of oil as outlined in the **Komatsu Engine Owner's Manual**.

## Fuel

Fill the fuel tank with clean and fresh **diesel fuel**. **DO NOT** fill the tank beyond capacity.

Pay attention to the fuel tank capacity when replenishing fuel. Refer to the fuel tank capacity listed on page 23, Specification Table 7.

The fuel tank cap must be closed tightly after filling. Handle fuel in a safety container. If the container does not have a spout, use a funnel. Wipe up any spilled fuel immediately.

## CAUTION:



Never fill the fuel tank while the engine is running or in the dark. Diesel spillage on a hot engine can cause a fire or explosion. If diesel spillage occurs, wipe up the spilled diesel completely to prevent fire hazards.

## Coolant

Use only drinkable tap water. If hard water or water with many impurities is used, the inside of the engine and radiator may become coated with deposits and cooling efficiency will be reduced.

An anticorrosion additive added to the water will help prevent deposits and corrosion in the cooling system. See the engine manual for further details.

**Table 11. Recommended Motor Oil**

Temperature Range	Type Oil
104° F ~ 23° F (40° C ~ -5° C)	SAE 30
23° F ~ 5° F (-5° C ~ -15° C)	SAE 20 or SAE 10W-30
Below 5° C (-15°)	SAE 10W or SAE 10W-30

## CAUTION :



When adding coolant or antifreeze to the radiator, do not remove the radiator cap until the unit has completely cooled.

Day-to-day addition of coolant is done from the reserve tank. When adding coolant to the radiator, **DO NOT** remove the radiator cap until the unit has completely cooled. See Table 12 for engine, radiator, and reserve tank coolant capacities. Make sure the coolant level in the reserve tank is always between the "H" and the "L" markings.

Table 12. Coolant Capacity

Engine and Radiator	16.9 Gal. (64.0 Liters)
Reserve Tank	2 Quarts (1.9 Liters)

## Operation in Freezing Weather

When operating in freezing weather, be certain the proper amount of antifreeze (Table 13) has been added.

Table 11. Anti-Freeze Operating Temperatures

Vol % Anti-Freeze	Freezing Point		Boiling Point	
	°C	°F	°C	°F
40	-24	-12	106	222
50	-37	-34	108	226

### NOTE

*When the antifreeze is mixed with water, the antifreeze mixing ratio must be less than 50%.*

## Cleaning the Radiator

The engine may overheat if the radiator fins become overloaded with dust or debris. Periodically clean the radiator fins with compressed air. Cleaning inside the machine is dangerous, so clean only with the engine turned off and the battery disconnected.

## Air Cleaner

Periodic cleaning/replacement is necessary. See maintenance section for instruction to cleaning/replacing air cleaner.

## Fan Belt Tension

A slack fan belt may contribute to overheating, or to insufficient charging of the battery. Inspect the fan belt for damage and wear. See maintenance section on replacing belts. To adjust tension:

1. Insert a bar between alternator and the cylinder block to fix alternator in position. When fixing the alternator in position, insert a wooden block between the bar and alternator to prevent damage to the alternator.
2. Loosen bolts and nuts located on the alternator.
3. Move alternator with the bar so the deflection of the belt is approx. 8mm.
4. Tighten the bolt and nuts to fix the alternator back to position.

The fan belt tension is proper if the fan belt bends 7 to 10 mm (Figure 29) when depressed with the thumb as shown below.

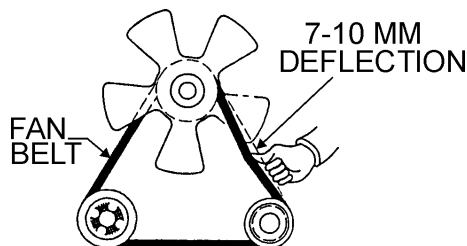


Figure 29. Fan Belt Tension

## CAUTION :



Never place hands near the belts or fan while the generator set is running.

## Battery Cable Installation

**ALWAYS** be sure the battery cables (Figure 30) are properly connected to the battery terminals as shown below. The **RED** cable is connected to the positive terminal of the battery, and the **BLACK** cable is connected to the negative terminal of the battery.

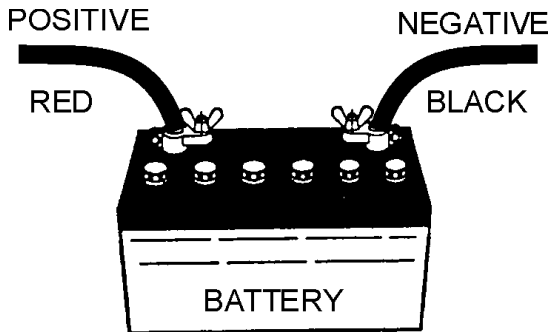


Figure 30. Battery Connections

## CAUTION :

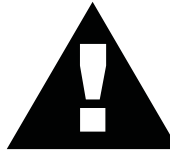


If the battery cable is connected incorrectly, electrical damage to the generator will occur. Pay close attention to the polarity of the battery when connecting the battery.

When connecting battery do the following:

1. **DO NOT** connect the battery cables to the battery terminals when the **Off/Manual/Auto** switch is in either the manual or auto position (ON). **ALWAYS** make sure that the Off/Manual/Auto switch is in the OFF position when connecting the battery.
2. Place a small amount of grease around both battery terminals. This will ensure a good connection and will help prevent corrosion around the battery terminals.

## CAUTION :



Inadequate battery connections may cause poor starting of the generator, and create other malfunctions.

### Wiring

Inspect the entire generator for bad or worn electrical wiring or connections. If any wiring or connections are exposed (insulation missing) replace wiring immediately.

### Piping and Hose Connection

Inspect all piping, oil hose, and fuel hose connections for wear and tightness. Tighten all hose clamps and check hoses for leaks.

If any hose (fuel or oil) lines are defective replace them immediately.

### Battery

This unit is of negative ground **DO NOT** connect in reverse. Always maintain battery fluid level between the specified marks. Battery life will be shortened, if the fluid level is not properly maintained. Add only distilled water when replenishment is necessary.

The battery is sufficiently charged if the specific gravity of the battery fluid is 1.28 (at 68°F). If the specific gravity should fall to 1.245 or lower, it indicates the battery is discharged and needs to be recharged or replaced.

Check to see whether the battery cables are loose. Poor contact may result in poor starting or malfunctions. Always keep the terminals firmly tightened. Coating the terminals with a thin film of grease will help inhibit corrosion.

## Single Phase Load

Always be sure to check the nameplate on the generator and equipment to insure the wattage, amperage and frequency requirements are satisfactorily supplied by the generator for operating the equipment.

Generally, the wattage listed on the nameplate of the equipment is its rated output. Equipment may require 130—150% more wattage than the rating on the nameplate, as the wattage is influenced by the efficiency, power factor and starting system of the equipment.

### NOTE

If wattage is not given on the equipment's name plate, approximate wattage may be determined by multiplying nameplate voltage by the nameplate amperage.

$$\text{WATTS} = \text{VOLTAGE} \times \text{AMPERAGE}$$

The power factor of this generator is 0.8. See Table 14. below when connecting loads.

**Table 14. Power Factor By Load**

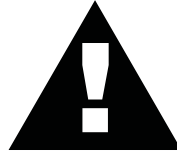
Type Of Load	Power Factor
Single-phase induction motors	0.4 - 0.75
Electric heaters, incandescent lamps	1.0
Fluorescent lamps, mercury lamps	0.4 - 0.9
Electronic devices, communication equipment	1.0

## Three Phase Load

When calculating the power requirements for 3-phase power use the following equation:

$$\text{KVA} = \frac{\text{VOLTAGE} \times \text{AMPERAGE} \times 1.732}{1000}$$

## CAUTION:



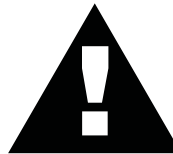
Motors and motor-driven equipment draw much greater current for starting than during operation.

An inadequate size connecting cable which cannot carry the required load can cause a voltage drop which can burn out the appliance or tool and overheat the cable.

- When connecting a resistance load such as an incandescent lamp or electric heater, a capacity of up to the generating set's rated output (kW) can be used.
- When connecting a fluorescent or mercury lamp, a capacity of up to the generating set's rated output (kW) multiplied by 0.6 can be used.
- When connecting an electric drill or other power tools, pay close attention to the required starting current capacity.

When connecting ordinary power tools, a capacity of up to the generating set's rated output (kW) multiplied by 0.8 can be used.

## CAUTION:



Before connecting this generator to any building's electrical system, a licensed electrician must install an isolation (transfer) switch. Serious injury or death may result without this transfer switch.

### NOTE

If output (kVA) is not given on the equipment nameplate, approximate output may be determined by multiplying voltage by amperage by  $\sqrt{3}$ .

## WARNING:



- The engine's exhaust contains harmful emissions. **ALWAYS** ventilate the exhaust when operating inside tunnels, excavations or buildings. Direct exhaust away from nearby personnel.

### Before Starting Engine

1. Check the lubricating oil level prior to starting the engine. Make sure the generator is level. The oil level must be maintained between two notches on the dipstick.
2. When there is not enough lubricating oil, fill the crankcase with high grade motor oil. Use a high quality detergent oil classified CC or higher (See Table 11 on page 43).
3. Check the coolant level in the radiator and subtank. Replenish with antifreeze as necessary. Always maintain the coolant level between the **FULL** and **LOW** markings on the coolant container. Be sure the radiator cap is fastened securely.
4. Check the fuel level on the fuel gauge. If fuel is low, fill the fuel tank with clean fresh unleaded automotive diesel. If diesel spillage occurs, completely wipe up the spilled fuel immediately.

### Before Starting

#### Generator and Control Panel

## CAUTION:



- **NEVER** start the engine with the **main**, **GFCI** or **load** circuit breakers in the **ON** position.

1. Be sure to disconnect the electrical load and switch the **main**, **load** and **G.F.C.I.** circuit breakers (Figure 31) to the "OFF" position prior to starting the engine.

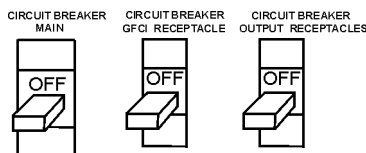


Figure 31. Main, GFCI and Load Circuit Breakers

## Jacket Water Heater and Internal Battery Charger 120 VAC Output Receptacles (OPTIONAL)

This generator is equipped with two 120 VAC, 20 amp output receptacles located on the output terminal panel, page 43, Figure 14.

The purpose of these receptacles is to provide power via commercial power to the jacket water heater and internal battery charger.

These receptacles will **ONLY** function when commercial power has been supplied to them (Figure 31). To apply commercial power to these receptacles, a power cord of adequate size will be required.

When using the generator in **hot** climates there is no reason to apply power to jacket water heater. However, if the generator will be used in **cold** climates it is always a good idea to apply power to the jacket water heater at all times. To apply power to the jacket water heater simply apply power to the jacket water heater receptacle via commercial power using an power cord of adequate size.

If the generator will be used daily, the battery should normally not require charging. If the generator will be idle (not used) for long periods of time, apply power to the battery charger receptacle via commercial power using an power cord of adequate size.

When connecting the generator to a isolation (transfer) switch, **ALWAYS** have power applied to the generator's internal battery charger. This will ensure that the engine will not fail due to a dead battery.

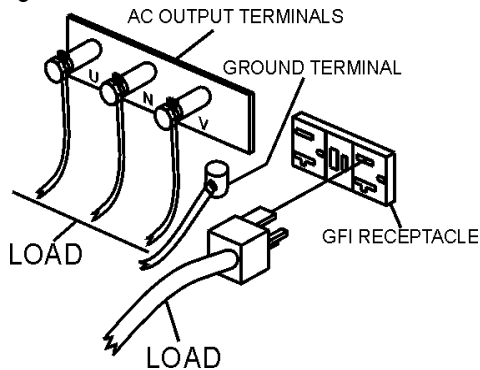
## CAUTION:



**ALWAYS** have power applied to the generator's internal battery charger when connecting the generator to a isolation (transfer) switch. Remember before connecting this generator to any buildings electrical system, have a **licensed** electrician perform the installation of the transfer switch.

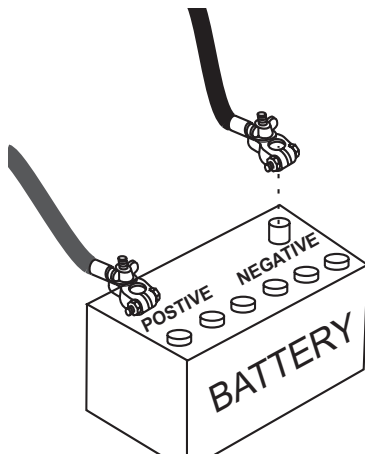
# DCA-400SPK — GENERATOR START-UP PROCEDURE (MANUAL)

2. Connect the load to the UVW terminals as shown in Figure 32. These terminals can be found on the output terminal panel, see page 35 Figure 14. To gain access to the output terminals lift the UVW cover. Make sure to tighten terminal nuts securely to prevent load wires from slipping out.



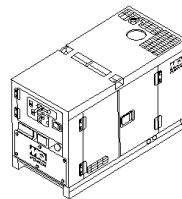
**Figure 32. UVW Terminal Lugs (Load)**

3. Connect the negative battery cable (BLACK) to the negative post on the battery (Figure 33).

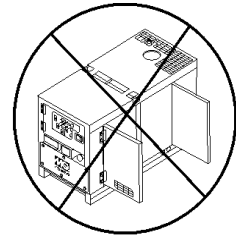


**Figure 33. Battery Connections**

4. Close all engine enclosure doors (Figure 34).



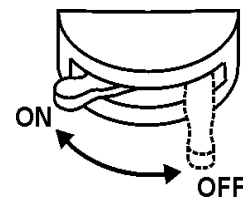
**CORRECT**



**INCORRECT**

**Figure 34. Engine Enclosure Doors**

5. Set the battery ON/OFF switch (Figure 35) to the ON position.



**Figure 35. Battery ON/OFF Switch**

6. When starting the generator in **COLD** weather conditions, press and hold the engine preheat button (Figure 36) until the preheat lamp (Figure 37) is lit (ON).



**Figure 36. Engine Pre-Heat Button**

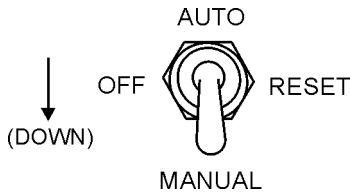


**Figure 37. Engine Pre-Heat Lamp**



# DCA-400SPK — GENERATOR START-UP PROCEDURE (MANUAL)

- Place the Off/Manual/Auto switch (Figure 38) in the **MANUAL** position (down). Observe that the engine begins to crank.



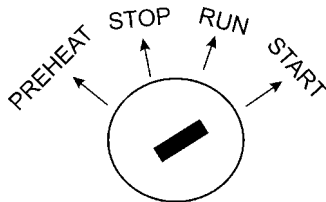
**Figure 38. Off/Manual/Auto Switch (Manual)**

- After engine starts, verify that the "Engine Running" status LED (Figure 39) on the Microprocessor Engine Control Module (MPEC) display is "ON" (lit).



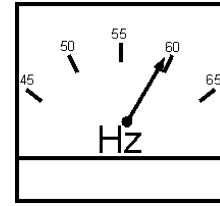
**Figure 39. MPEC Engine Running Status LED**

- If the generator is equipped with a ignition switch, turn the key to "Start" position (Figure 40). Once the engine starts, release the key to the "on" position.



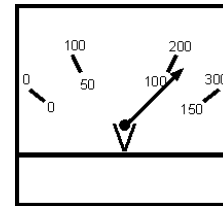
**Figure 40. Engine Ignition Switch**

- The generator's frequency meter (Figure 41) displays the 60 cycle output frequency in **HERTZ**.

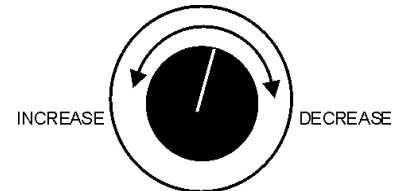


**Figure 41. Frequency Meter (Hz)**

- The generator's voltage meter (Figure 42) displays the 120 VAC in **VOLTS**. If the voltage is not within the specified frequency tolerance, use the voltage adjustment control knob (Figure 43) to increase or decrease the desired voltage.

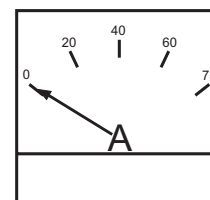


**Figure 42. Voltage Meter (Volts)**



**Figure 43. Voltage Adjust Control Knob**

- The ammeter (Figure 44) will indicate zero amps with no load applied. When a load is applied, this meter will indicate the amount of current that the load is drawing from the generator's alternator.



**Figure 44. Ammeter (No Load)**

# DCA-400SPK — GENERATOR START-UP PROCEDURE (MANUAL)

13. The engine oil pressure gauge (Figure 45) will indicate the oil pressure (kg/ cm<sup>2</sup>) of the engine. Under normal operating conditions the oil pressure should be approximately 25 psi.



Figure 45. Oil Pressure Gauge

14. The coolant temperature gauge (Figure 46) will indicate the coolant temperature. Under normal operating conditions the coolant temperature should be between 165 and 215 degrees Fahrenheit (Green Zone).

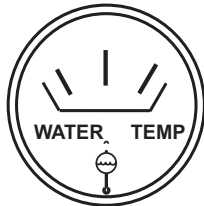


Figure 46. Coolant Temperature Gauge

15. The tachometer (Figure 47) will indicate the speed of the engine when the generator is operating. Under normal operating conditions this speed should be approximately 1800 RPM's.

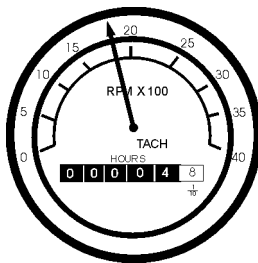


Figure 47. Engine Tachometer

16. Turn the MAIN, GFCI and LOAD circuit breakers to their "ON" position (Figure 48).

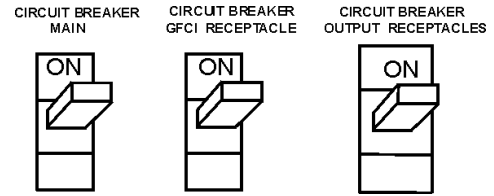


Figure 48. Main and GFCI Circuit Breakers

17. Observe the generator's ammeter (Figure 49) and verify that it reads the anticipated amount of current with respect to the load. Remember the ammeter will only display a current reading if the load is in use.

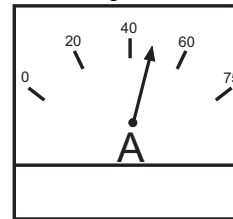


Figure 49. Ammeter (Load)

18. The generator will run until manually stopped or an abnormal condition occurs.

# DCA-400SPK — GENERATOR START-UP PROCEDURE (AUTO)

## CAUTION:



Before connecting this generator to any building's electrical system, a **licensed electrician** must install an isolation (transfer) switch. Serious ***injury*** or ***death*** may result without this transfer switch.

## CAUTION:



When connecting the generator to a isolation (transfer) switch, **ALWAYS** have power applied to the generator's internal battery charger. This will ensure that the engine will not fail due to a dead battery.

Starting the generator in the "**AUTO**" mode is similar to starting the generator in the "**MANUAL**" mode, with a few exceptions.

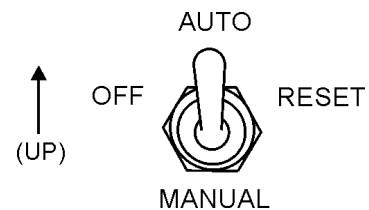
## CAUTION:



When running the generator in the **AUTO** mode, remember the generator can start up at any time without warning. **NEVER** attempt to perform any maintenance when the generator is in the auto mode.

When starting generator in Auto mode use the "Manual Start-up" procedure except where noted (see below).

1. Perform steps 1 through 6 (Before Starting, page 47-48) as outlined in the manual starting procedure.
2. Apply commercial power to the internal battery charger receptacle (to ensure good starting) via commercial power. An external power cord will be required.
3. Apply commercial power to the jacket water heater receptacle (not necessary for warm climates) via commercial power. An external power cord will be required.
4. Place the Off/Manual/Auto switch (Figure 50) in the **AUTO** position (up).



**Figure 50. Off/Manual Auto Switch (AUTO)**

5. Continue to follow the steps outline in the manual start-up procedure (start at step 11, page 49).

# DCA-400SPK — GENERATOR SHUTDOWN PROCEDURE

## Engine Shutdown

To shutdown the generator use the following procedure:

1. Place both the **MAIN, GFCI** and **LOAD** circuit breakers to the "OFF position".
2. Let the engine cool by running it for 3-5 minutes with no load applied.
3. Place the Off/Manual/Auto Switch (Figure 51) in the "**OFF/RESET**" position

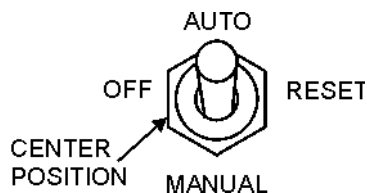


Figure 51. Off/Manual Auto Switch (OFF)

4. Verify that the "Engine Running" status LED (Figure 52) on the Microprocessor Engine Control Module (MPEC) display is "OFF" (not lit).



Figure 52. MPEC Engine Running Status LED (OFF)

5. Remove the load from the UVWO terminal strip (Figure 18 on page 48).

## Emergency Stop

1. To stop the engine in the event of an emergency, **PUSH** the emergency stop button (Figure 53) inward. This button is located on the generator's engine operating panel, see page 30, Figure 11.

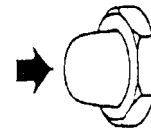


Figure 53. Emergency Stop Button

## CAUTION:



**NEVER** stop the engine suddenly except in an emergency. **DO NOT** use the emergency stop switch as a method of shutting down the engine. This switch is **ONLY** to be used in the event of an emergency.



## General Inspection

Prior to each use, the generating set should be cleaned and inspected for deficiencies. Check for loose, missing or damaged nuts, bolts or other fasteners. Also check for fuel or oil leaks.

## Air Cleaner

Every 50 hours: If dust indicator is red, clean the air cleaner element.

### Outer Element:

1. Loosen wing bolt, remove dust cup, then remove wing nut and take out element.
2. Clean the inside of the body and cover using a damp cloth.
3. Blow dry with compressed air (0.69Mpa [7kgf.cm<sup>2</sup>, 99.4 PSI] maximum) against the side of the element along the pleats. Then blow dry against outside along the pleats, then against inside again.
4. Remove one seal each time the element is cleaned.
5. Replace the outer element after cleaning it 6 times or after one year. Replace the outer element if indicator is red even after cleaning it.
6. Check the inner cylinder element clamping nut for looseness, and retighten if necessary.
7. If seal washer is damaged or the threads of wing nut are damaged, replace.
8. Remove evacuator valve and clean it with compressed air. Reinstall.

### Inner element (if equipped)

1. Remove the cover and outer element, then remove the inner element.
2. Cover the air connector opening (outer side) with clean cloth or cloth tape.
3. Clean the inside of the body. Remove air connector opening protection.
4. Install a new inner cylinder element to the cylinder and tighten the nut.
5. Install element.
6. After replacing the element, press the button of the dust indicator to return the red piston to its original position.

## Fuel Addition

Add diesel fuel (the grade may vary according to season and locations). Always pour through the mesh filter.

### Removing Water from the Tank

After prolonged use, water and other impurities accumulate in the bottom of the tank. Occasionally remove the drain cock and drain the contents. During cold weather, the greater the empty volume inside the tank, the easier it is for water to condense. This can be reduced by always keeping the tank as full as possible.

### Air Removal

If air enters the fuel injection system of a diesel engine, starting becomes impossible. After running out of fuel, or after disassembling the fuel system, bleed the system according to the following procedure.

To restart after running out of fuel, turn the key switch to the "START" position for 15-30 seconds. Try again, if needed. This unit is equipped with an automatic air bleeding system.

### Service Daily

If engine is operating in very dusty and dry grass conditions, a clogged air cleaner will result in high fuel consumption, loss of power and excessive carbon buildup in the combustion chamber.

### Cleaning the Fuel Strainer

Clean the fuel strainer if it contains dust or water. Remove dust or water in the strainer cap and wash it in diesel. Securely fasten the fuel strainer cap so that fuel will not leak. Check the fuel strainer every 200 hours of operation or once a month.

### Check Oil Level

Check the crankcase oil level prior to each use, or when the fuel tank is filled. Insufficient oil may cause severe damage to the engine. Make sure the generator is level. The oil level must be between the two notches on the dipstick as shown in Figure 28, page 43.

### Flushing Out Radiator and Changing Coolant

1. Stop the engine and allow to cool. Tighten valve of the corrosion resistor (if equipped).
2. Turn water filler cap slowly and remove it.
3. Prepare a container to catch the coolant, then open drain plug of the radiator or heat exchanger and drain plug of the engine, and drain the coolant.
4. After draining the coolant, close drain plugs and fill with tap water.

5. When the water level is near the mouth of the water filler, open drain plugs and start the engine, and run at low idling. Keep the engine running at low idling and flush the radiator for about 10 minutes.
6. Adjust the flow of the water flowing in and draining out to ensure that the radiator is always full during the flushing operation, While flushing water through the system, watch carefully the water inlet hose does not come out of the radiator filler port.
7. After flushing, stop the engine, open drain plug and drain the water, then close drain plugs.
8. After draining the water, flush the system with a flushing agent. See instructions on flushing agent label.
9. After flushing, open drain plugs and drain out all the water, then close drain plugs and add tap water so the water level is near the mouth of the water filler.
10. When the water level is near the mouth of the water filler, open drain plugs and start the engine, run at low idling and continue to flush the system until clean water comes out. Adjust the flow of the water flowing in and draining out to ensure the radiator is always full during the flushing operation.
11. When clean water comes out, stop the engine, drain all the water, then close drain plugs.
12. Remove the corrosion resistor (if equipped) and open valve.
13. Supply water until it flows over the water filler.
14. Drain the water inside reserve tank, clean the inside of the reserve tank, then fill with coolant/water mixture to between the full and low lines.
15. Stop the engine, wait for 3 minutes, add tap water until the water level reaches near the water filler port, then tighten the radiator cap.

#### **Check Electric Heater (If equipped)**

Before starting in cold weather (once a year), please contact your Komatsu distributor for inspection. Remove electric heater from the engine intake manifold and check for disconnections or dirt. When checking or installing the electric heater, replace the gasket with a new part.

#### **Changing Oil**

1. Make sure the oil is cool before changing.
2. Set a container directly under the drain plug of the oil pan. Loosen the drain plug slowly.
3. Check the drained oil for excessive metal particles or foreign material. Contact the distributor if there is metal particles or foreign material.
4. Using a filter wrench, turn filter cartridge to the left to remove it. If the filter cartridge is filled with a large amount of oil, wait 10 minutes or so before removing. Make sure there is no old gasket stuck on the filter holder.
5. Tighten drain plug. Clean the filter holder, fill the new filter cartridge with clean engine oil, coat the packing and thread of the new filter cartridge with engine oil, then install it to the filter holder. Tighten until the gasket surface contacts the seal surface of the filter holder, then tighten it a further 3/4 to 1 turn.
6. Add engine oil through oil filler until the oil level is between the H and L marks on the dipstick.
7. Run the engine at idling for a short time, then stop the engine. Recheck the oil level and fill as necessary.

#### **Replacing fuel filter**

1. Set the container under the filter cartridge to catch fuel.
2. Using a filter wrench, turn the filter cartridge to the left to remove it.
3. Clean the filter holder, fill the new filter cartridge with fuel, coat the packing surface of the filter cartridge with engine oil, then install the cartridge to the filter holder.
4. When installing, tighten until the packing surface contacts the seal surface of the filter holder then tighten a further 2/3 of a turn. If the filter cartridge is tighten too much, the packing will be damaged and will cause fuel leakage. Fuel leakage will occur if the filter cartridge is not tightened enough. Always tighten to the correct angle.
5. After replacing filter cartridge, loosen air bleed plug.
6. Loosen the knob of feed pump, and pump it up and down until no bubbles come out with the fuel from air bleed plug.

7. After bleeding the air, tighten air bleed plug, then push in the knob of feed pump and lock it in position.
8. Replace Corrosion resistor cartridge (if equipped)
9. Screw in valves at the top of the corrosion resistor.
10. Using a filter wrench, turn the cartridge to the left to remove it.
11. Coat the seal surface of the new cartridge with engine oil and install it to the filter holder.
12. Tighten until the packing surface contacts the seal surface of the filter holder, then tighten a further 2/3 of a turn.
13. Open valves.

### Cleaning breather element

1. Loosen the clamp, then remove the hose and take out breather. Wipe off the dirt around the breather. Check the O-ring, and replace if necessary.
2. Wash the breather in diesel fuel or flushing oil, blow dry with compressed air, then reinstall it.
3. Inspect the hose and if there is any deteriorated oil stuck inside the hose. Replace hose if necessary.

### Greasing

Using a grease pump, grease the fan hub (1 place) and tension pulley (2 places).

### Generator Storage

For storage of the generator for over 30 days, the following is required:

- Fill the fuel tank completely, lubricate and change oil.
- Disconnect the negative terminals of the battery and cover it, or remove it from the machine and store it separately.
- If the ambient temperature is expected to drop below 0°C, add antifreeze to the radiator.

Removal from long term storage:

- Apply oil to the engine valve and rocker arms, and examine the operating condition of the valves.
- Remove the oil filler pipe from the turbocharger oil inlet port, add 0.5-1L (0.13-0.26gal) of oil to the turbocharger, reinstall the oil filler pipe.
- Change the oil in engine oil pan.
- Replace all the filters.
- Flush the inside of the cooling system.
- Drain the water from the fuel tank and bleed the air from the fuel system.
- If the engine has not been started for more than one year, contact your Komatsu distributor to have engine overhauled.



**TABLE 15.**

<b>INSPECTION / MAINTENANCE</b>		10 Hrs DAILY	250 Hrs	500 Hrs	1000 Hrs
<b>ENGINE</b>	Check Engine Fluid Levels	X			
	Check Air Cleaner	X			
	Check Battery Acid Level	X			
	Check Fan Belt Condition	X			
	Check for Leaks	X			
	Check for Loosening of Parts	X			
	Replace Engine Oil and Filter * <sup>1</sup>		X		
	Clean Air Filter		X		
	Drain Bottom of Fuel Tank		X		
	Clean Unit, Inside and Outside		X		
	Change Fuel Filter * <sup>2</sup>			X	
	Clean Radiator and Check Coolant Protection Level			X	
	Replace Air Filter Element				X
	Change Corrosion Resistor				X
	Check all Hoses and Clamps				X
Clean Inside of Fuel Tank				X	
<b>GENERATOR</b>	Measure Insulation Resistance Over 3M ohms		X		

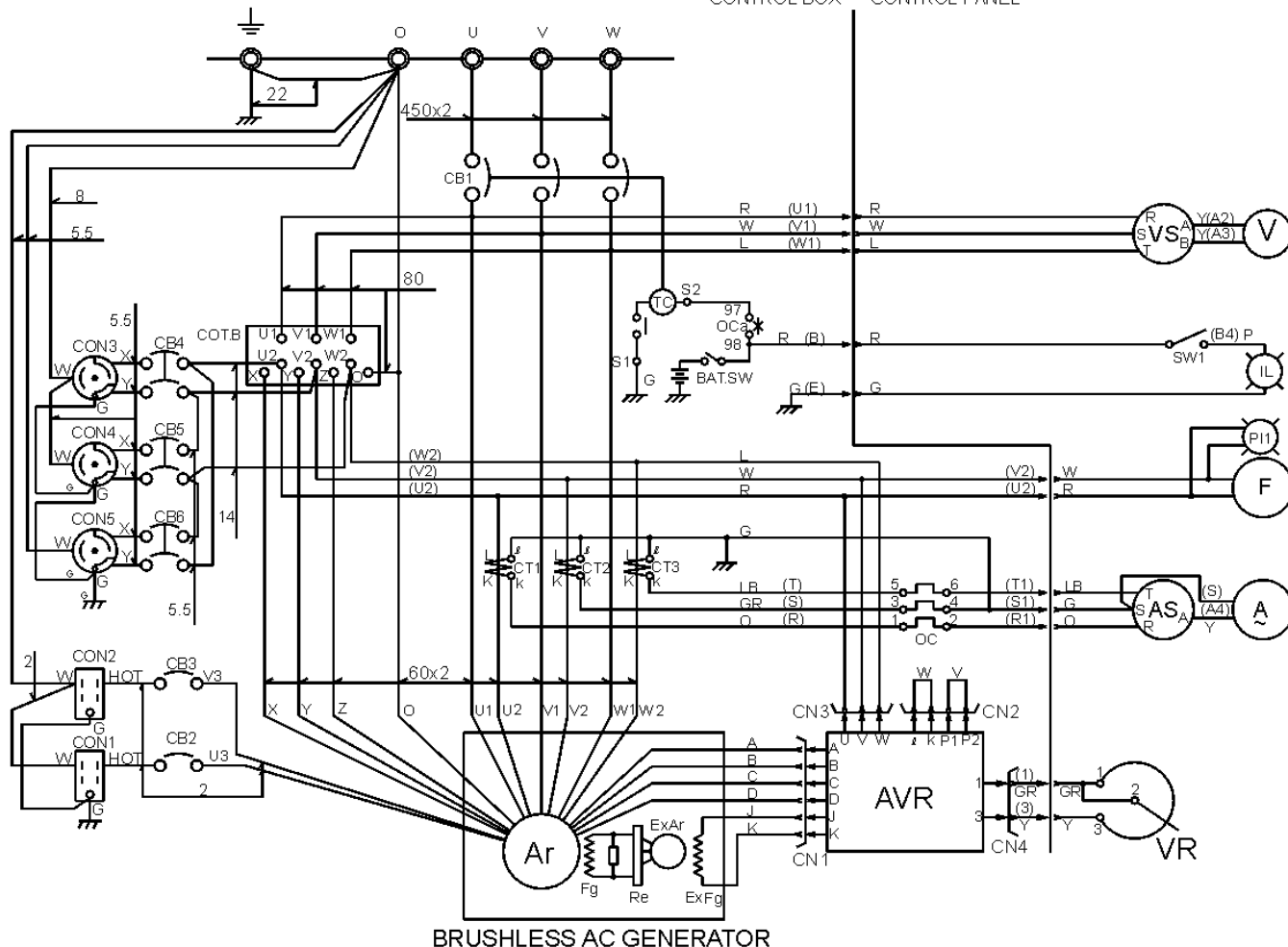
\*<sup>1</sup> Replace engine oil and filter at 100 hours, first time only.

\*<sup>2</sup> Replace fuel filter at 250 Hours, first time only.

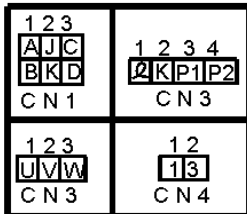
# DCA-400SPK — GENERATOR WIRING DIAGRAM

DCA400SSK GENERATOR WIRE DIAGRAM

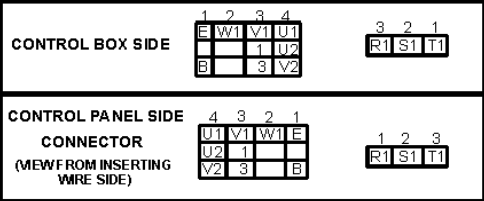
CONTROL BOX      CONTROL PANEL



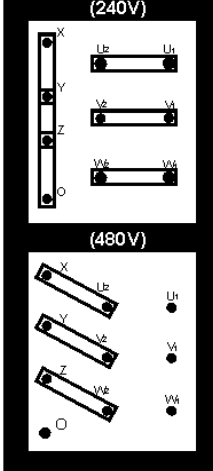
### AVR CONNECTOR



(VIEW FROM INSERTING WIRE SIDE)



### SETTING FOR OUTPUT VOLTAGE

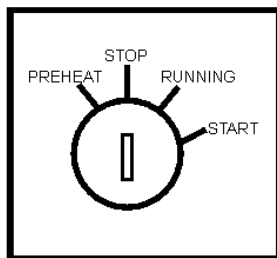
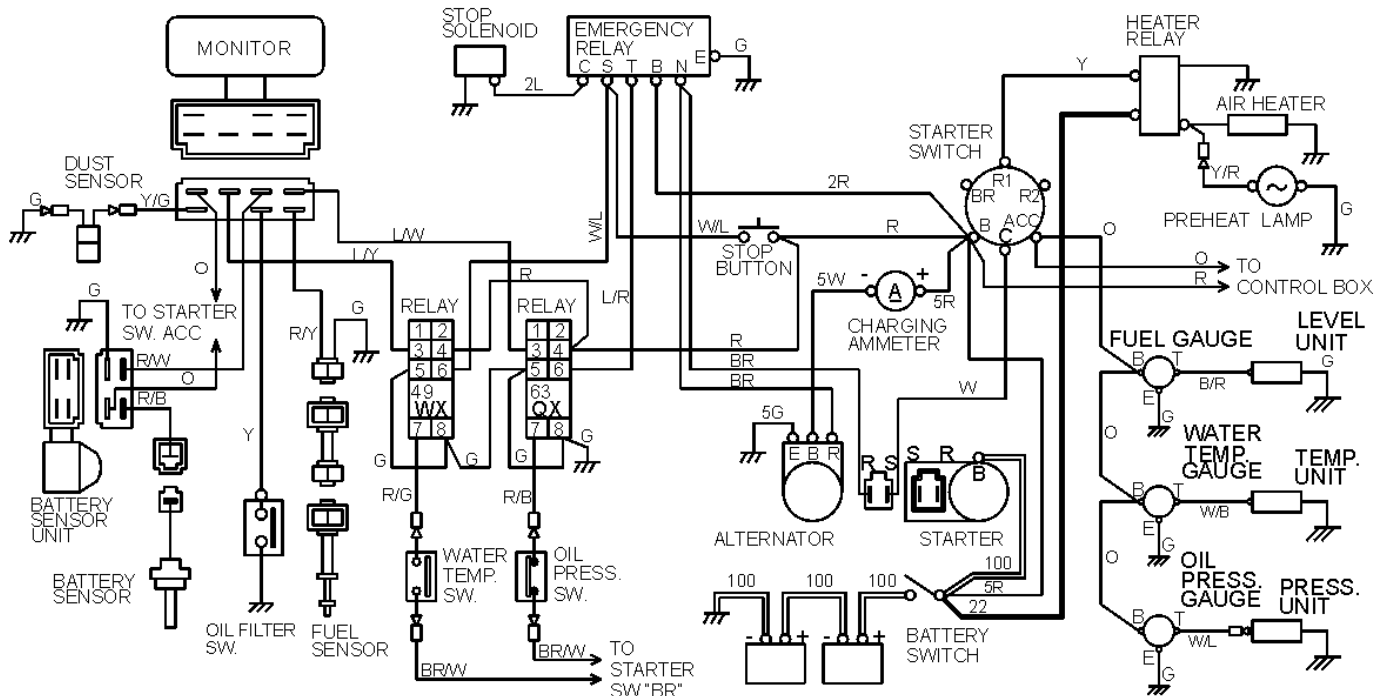


MARK	NAME
Ar	MAIN GENERATOR ARMATURE WINDING
Fg	MAIN GENERATOR FIELD WINDING
ExAr	EXCITER ARMATURE WINDING
ExFg	EXCITER FIELD WINDING
AVR	AUTOMATIC VOLTAGE REGULATOR
VR	VOLTAGE REGULATING RHEOSTAT
Re	RECTIFIER
CT1~3	CURRENT TRANSFORMER (750/5A)
C B 1	CIRCUIT BREAKER (1000A)
OC	OVER CURRENT RELAY
COT. B	VOLTAGE CHANGE-OVER BOARD
AS	AMMETER CHANGE-OVER SWITCH
A	AC AMMETER (0~750, 1500A)
VS	VOLTMETER CHANGE-OVER SWITCH
V	AC VOLTMETER (0~600)
F	FREQUENCY METER (45~65HZ)
PI1	PILOT LAMP
CB2, 3	AUX. CIRCUIT BREAKER (20A)
CB4~6	AUX. CIRCUIT BREAKER (50A)
CON1, 2	AUX POWER RECEPTACLE (20A)
CON3~5	AUX POWER RECEPTACLE (50A)
IL	PANEL LIGHT
SW1	PANEL LIGHT SWITCH

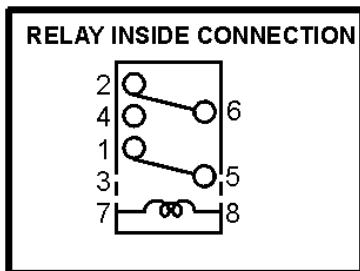
WIRE SIZE	COLOR CODE
100: 100 mm <sup>2</sup>	CODE/WIRE COLOR
80: 80 mm <sup>2</sup>	B BLACK R RED
38: 38 mm <sup>2</sup>	L BLUE W WHITE
22: 22 mm <sup>2</sup>	BR BROWN Y YELLOW
14: 14 mm <sup>2</sup>	G GREEN LB LIGHT BLUE
8: 8 mm <sup>2</sup>	GR GRAY LG LIGHT GREEN
5.5: 5.5 mm <sup>2</sup>	V VIOLET O ORANGE
2: 2 mm <sup>2</sup>	P PINK


# DCA-400SPK — ENGINE WIRING DIAGRAM

DCA400SSK ENGINE WIRE DIAGRAM

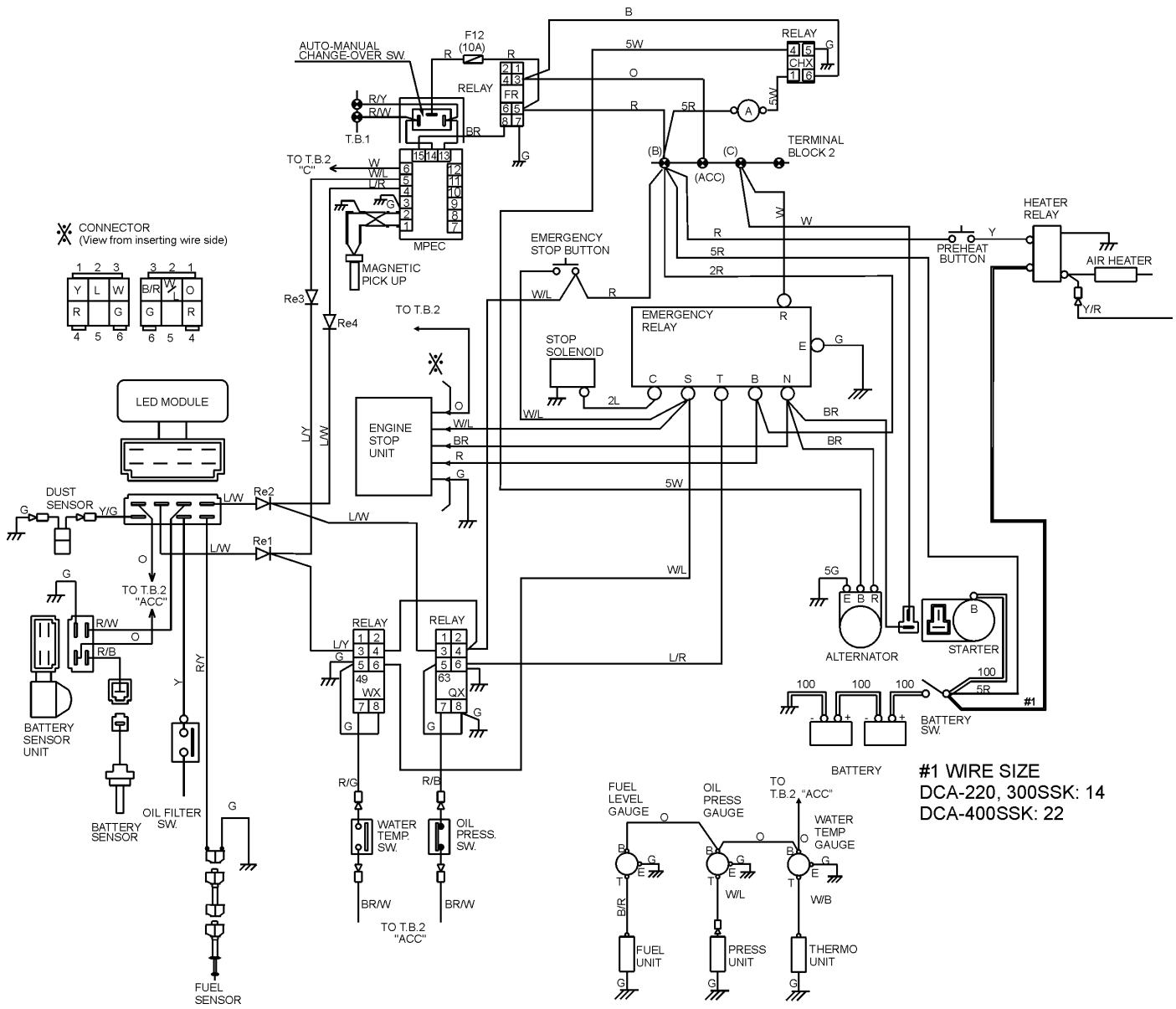


	STARTER SWITCH CONNECTION					
	B	BR	R1	R2	C	ACC
STOP	●					
PREHEAT	●	●	●			●
RUNNING	●	●				●
START	●	●		●	●	●

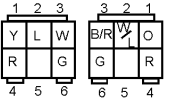


WIRE SIZE	COLOR CODE			
100: 100 mm <sup>2</sup>	CODE/ WIRE COLOR			
38: 38 mm <sup>2</sup>	B	BLACK	R	RED
22: 22 mm <sup>2</sup>	L	BLUE	W	WHITE
14: 14 mm <sup>2</sup>	BR	BROWN	Y	YELLOW
5: 5 mm <sup>2</sup>	G	GREEN	LB	LIGHT BLUE
2: 2 mm <sup>2</sup>	GR	GRAY	LG	LIGHT GREEN
NO MARK :	V	VIOLET	O	ORANGE
1.25 mm <sup>2</sup>	P	PINK		

# DCA-400SPK — ENGINE WIRING DIAGRAM (MPEC)

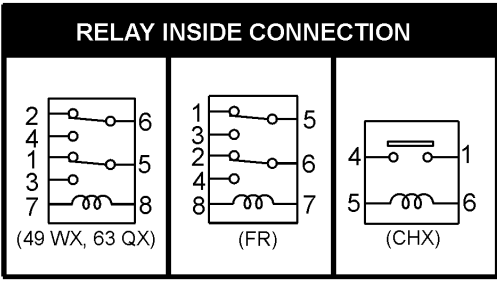


✕ CONNECTOR  
(View from inserting wire side)



#1 WIRE SIZE  
DCA-220, 300SSK: 14  
DCA-400SSK: 22

COLOR CODE TABLE			
CODE/ WIRE COLOR			
B	BLACK	R	RED
L	BLUE	W	WHITE
BR	BROWN	Y	YELLOW
G	GREEN	LB	LIGHT BLUE
GR	GRAY	LG	LIGHT GREEN
V	VIOLET	O	ORANGE
P	PINK		



WIRE SIZE TABLE
100: 100mm <sup>2</sup>
38: 38mm <sup>2</sup>
22: 22mm <sup>2</sup>
14: 14mm <sup>2</sup>
5 : 5mm <sup>2</sup>
2 : 2mm <sup>2</sup>
NO MARK: 2 mm <sup>2</sup>

# DCA-400SPK — TROUBLESHOOTING (ENGINE)

Practically all breakdowns can be prevented by proper handling and maintenance inspections, but in the event of a breakdown, use the tables shown for

diagnosis based on the Engine Troubleshooting (Table 16). If the problem cannot be remedied, consult our company's business office or service plant.

**TABLE 16. ENGINE TROUBLESHOOTING**

SYMPTOM	POSSIBLE PROBLEM	SOLUTION
Engine does not start.	No fuel?	Replenish fuel.
	Air in the fuel system?	Bleed system.
	Water in the fuel system?	Remove water from fuel tank.
	Fuel pipe clogged?	Clean fuel pipe.
	Fuel filter clogged?	Clean or change fuel filter.
	Excessively high viscosity of fuel or engine oil at low temperature?	Use the specified fuel or engine oil.
	Fuel with low cetane number?	Use the specified fuel.
	Fuel leak due to loose injection pipe retaining nut?	Tighten nut.
	Incorrect injection timing?	Adjust.
	Fuel cam shaft worn?	Replace.
	Injection nozzle clogged?	Clean injection nozzle.
	Injection pump malfunctioning?	Repair or replace.
	Seizure of crankshaft, camshaft, piston, cylinder liner or bearing?	Repair or replace.
	Compression leak from cylinder?	Replace head gasket, tighten cylinder head bolt, glow plug and nozzle holder.
	Improper valve timing?	Correct or replace timing gear.
Piston ring and liner worn?	Replace.	
Excessive valve clearance?	Adjust.	
Starter does not run.	Battery discharged?	Charge battery.
	Starter malfunctioning?	Repair or replace.
	Key switch malfunctioning?	Repair or replace.
	Wiring disconnected?	Connect wiring.

# DCA-400SPK — TROUBLESHOOTING (ENGINE)

## TABLE 16. ENGINE TROUBLESHOOTING (CONTINUED)

SYMPTOM	POSSIBLE PROBLEM	SOLUTION
Engine revolution is not smooth.	Fuel filter clogged or dirty?	Clean or change.
	Air cleaner clogged?	Clean or change.
	Fuel leak due to loose injection pipe retaining nut?	Tighten nut.
	Injection pump malfunctioning?	Repair or replace.
	Incorrect nozzle opening pressure?	Adjust.
	Injection nozzle stuck or clogged?	Repair or replace.
	Fuel over flow pipe clogged?	Clean.
	Governor malfunctioning?	Repair.
Either white or blue exhaust gas is observed.	Excessive engine oil?	Reduce to the specified level.
	Piston ring and liner worn or stuck?	Repair or replace.
	Incorrect injection timing?	Adjust.
	Deficient compression?	Adjust top clearance.
Either black or dark gray exhaust gas is observed.	Overload?	Lessen the load.
	Low grade fuel used?	Use the specified fuel.
	Fuel filter clogged?	Clean or change.
	Air cleaner clogged?	Clean or change.
	Deficient nozzle injection?	Repair or replace the nozzle.
Deficient output.	Incorrect injection timing?	Adjust.
	Engine's moving parts seem to be seizing?	Repair or replace.
	Uneven fuel injection?	Repair or replace the injection pump.
	Deficient nozzle injection?	Repair or replace the nozzle.
	Compression leak?	Replace head gasket, tighten cylinder head bolt, glow plug and nozzle holder.

# DCA-400SPK — TROUBLESHOOTING (GENERATOR/ENGINE)

Practically all breakdowns can be prevented by proper handling and maintenance inspections, but in the event of a breakdown, use the tables shown for diagnosis based on the Engine and Radiator Troubleshooting (Table 17). If the problem cannot be remedied, consult our company's business office or service plant.

**TABLE 17. GENERATOR TROUBLESHOOTING**

SYMPTOM	POSSIBLE PROBLEM	SOLUTION
No Voltage Output	AC Voltmeter defective?	Check output voltage using a voltmeter.
	Is wiring connection loose?	Check wiring and repair.
	Is AVR defective?	Replace if necessary.
	Defective Rotating Rectifier?	Check and replace.
Low Voltage Output	Is engine speed correct?	Turn engine throttle lever to "High".
	Is wiring connections loose?	Check wiring and repair.
	Defective AVR?	Replace if necessary.
High Voltage Output	Is wiring connections loose?	Check wiring and repair.
	Defective AVR?	Replace if necessary.
Circuit Breaker Tripped	Short Circuit in load?	Check load and repair.
	Over current?	Confirm load requirements and reduce.
	Defective circuit breaker?	Check and replace.
	Over current Relay actuated?	Confirm load requirement and replace.



## TABLE 18. MPEC TROUBLESHOOTING

Sympton	Possible Cause	Solution
Low oil pressure light is on.	Low oil level?	Fill oil level.
	Oil pressure sending unit failure?	Replace oil pressure sending unit.
	Time delay malfunction in MPEC?	Refer to dealer.
	Wire shorted?	Inspect/repair wire.
Low coolant level light is on.	Low coolant level?	Fill coolant level.
	Sending unit failure?	Replace sending unit.
	Low battery voltage?	Replace/charge battery.
High coolant temperature light is on.	Fan belt tension incorrect?	Tighten/replace fan belt.
	Air flow is not circulation through radiator?	Clean/repair radiator grill.
	Doors open?	Close doors.
	Exhaust leaking?	Replace/repair gaskets or faulty part.
	Generator being overloaded?	Check/reduce load.
	Thermostat failure?	Replace thermostat.
	Air intake blocked?	Clear all air intakes.
	Temperature switch failure?	Replace temperature switch.
Overcrank light is on.	No or low Fuel?	Fill fuel level.
	MPEC needs to be calibrated?	Refer to dealer.
Overspeed light is on.	RPM engine speed too high?	Adjust RPM.
	Governor actuator needs to be adjusted?	Adjust governor actuator.
	Governor controller needs to be adjusted?	Adjust governor controller.
	MPEC needs to be calibrated?	Refer to dealer.
Loss of MPU light(s) or on.	Magnetic pick up out of adjustment?	Adjust magnetic pick up.
	Magnetic pick up dirty?	Clean magnetic pick up.

## EXPLANATION OF CODE IN REMARKS COLUMN

How to read the marks and remarks used in this parts book.

### Items Found In the “Remarks” Column

**Serial Numbers**-Where indicated, this indicates a serial number range (inclusive) where a particular part is used.

**Model Number**-Where indicated, this shows that the corresponding part is utilized only with this specific model number or model number variant.

### Items Found In the “Items Number” Column

All parts with same symbol in the number column, \*, #, +, or %, belong to the same assembly or kit.

Note: If more than one of the same reference number is listed, the last one listed indicates newest (or latest) part available.

## DCA-400SPK W/KOMATSU SA6D140E-2 DIESEL ENGINE

### 1 to 5 Units

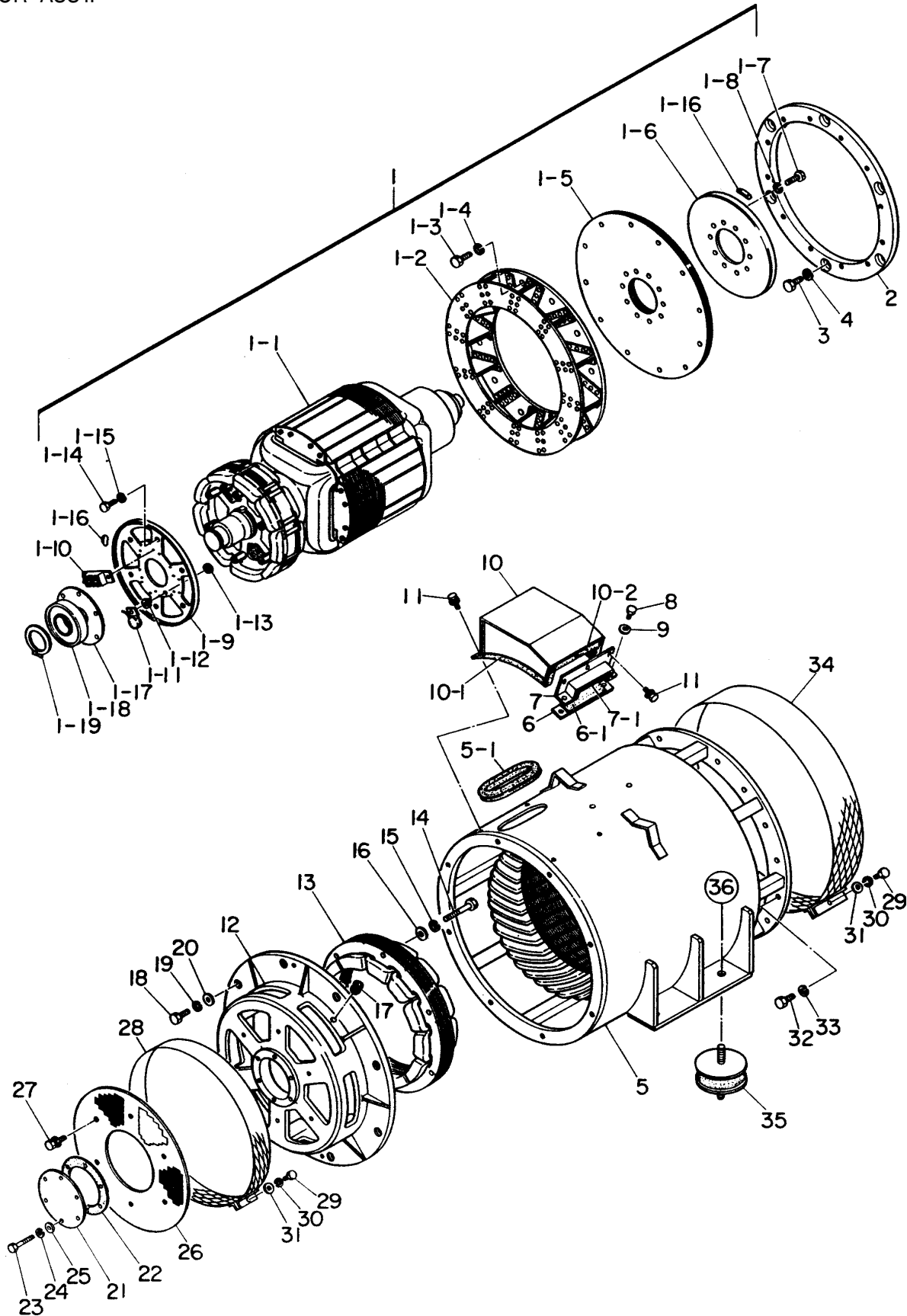
Qty.	P/N	Description
10 .....	6125817051 ...	AIR FILTER
10 .....	6003117111 ...	FUEL FILTER
10 .....	6002111231 ...	OIL FILTER
5 .....	6004111171 ...	CARTRIDGE, CORROSION RESISTOR
1 .....	0601804887 ...	CIRCUIT BREAKER
1 .....	0601810575 ...	PILOT LAMP, ENGINE TROUBLE
1 .....	0601810576 ...	PILOT LAMP, ENGINE TROUBLE
1 .....	0412122258 ...	ENGINE FAN BELT
1 .....	6008155390 ...	SWITCH, STARTER
5 .....	615 .....	KEY SET, STARTER SWITCH (2)
2 .....	0602122281 ...	OIL SWITCH
1 .....	6212619610 ...	RADIATOR HOSE (UPPER)
1 .....	6212616930 ...	RADIATOR HOSE (LOWER)
1 .....	0605505030 ...	FUEL CAP
1 .....	061820625 ...	AUTOMATIC VOLTAGE REGULATOR
1 .....	0601807307 ...	MAIN CIRCUIT BREAKER
1 .....	0601805840 ...	CIRCUIT BREAKER
1 .....	0601802525 ...	HANDLE, MAIN CIRCUIT BREAKER
1 .....	0601840073 ...	VOLTAGE REGULATOR (RHEOSTAT)
2 .....	0601840121 ...	KNOB, VOLTAGE REGULATOR
1 .....	0601810072 ...	PILOT LAMP
2 .....	0601810261 ...	BULB, PILOT LAMP
1 .....	2016012191 ...	CAP, RADIATOR
1 .....	0602122200 ...	UNIT, OIL PRESSURE
1 .....	0602123206 ...	UNIT, WATER TEMPERATURE
1 .....	0602121052 ...	CHARGING AMMETER

### NOTE

Part number on this Suggested Spare Parts list may supercede/replace the P/N shown in the text pages of this book.

# DCA-400SPK GENERATOR ASSY.

GENERATOR ASSY.



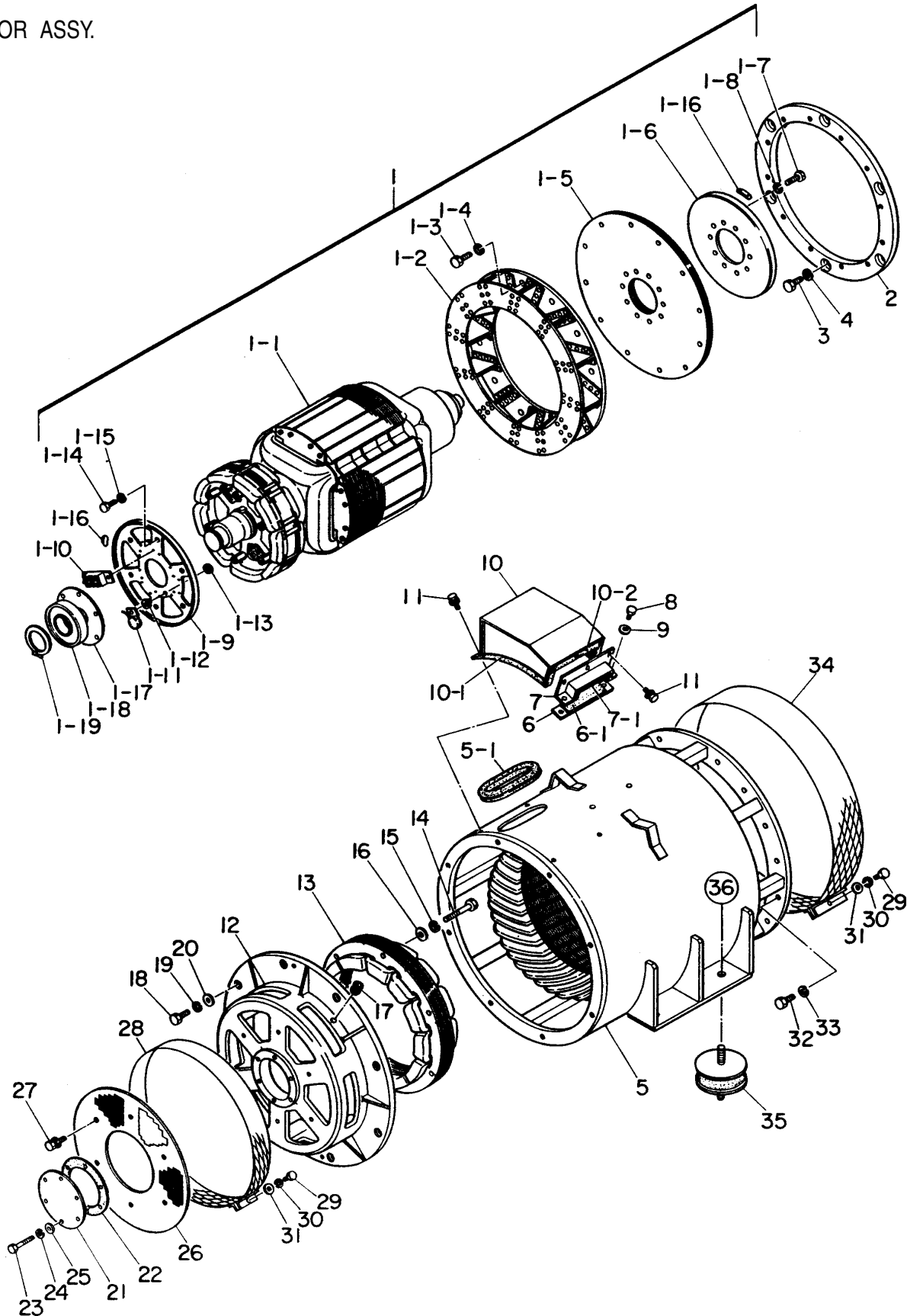
# DCA-400SPK GENERATOR ASSY.

## GENERATOR ASSY.

<u>NO.</u>	<u>PART NO.</u>	<u>PART NAME</u>	<u>QTY.</u>	<u>REMARKS</u>
1	8211000012	ROTOR ASSY.	1	
1-1		FIELD ASSY.	1	
1-2	8201070002	FAN		
1-3	0012112040	HEX. HEAD BOLT	12	
1-4	0042512000	LOCK WASHER	12	
1-5	8201611004	COUPLING DISK	12	
1-6	8201015003	BALANCING PLATE	1	
1-7	0012116040	HEX. HEAD BOLT	10	
1-8	0042616000	LOCK WASHER	10	
1-9	8171026013	SET PLATE RECTIFIER	1	
1-10	0601821349	RECTIFIER .....	3	PT3610
1-11	0601822615	SURGE ABSORBER .....	1	ERZM20JK621B
1-12	8171020004	INSULATOR WASHER	1	
1-13	8171020504	INSULATOR WASHER	1	
1-14	0010110020	HEX. HEAD BOLT	6	
1-15	0040010000	LOCK WASHER	6	
1-16	0601000209	BALANCING WEIGHT KIT	1	
1-17	8201014004	BEARING FLANGE	1	
1-18	0071906315	BEARING .....	1	76315DDUC3
1-19	0080000075	SNAP RING	1	
2	8201614003	COUPLING RING	1	
3	0012116040	HEX. HEAD BOLT	6	
4	0042516000	LOCK WASHER	6	
5	8211340303	STATOR ASSY.	1	
5-1	0226200495	RUBBER SEAL	1	
6	8211323004	CLAMPER	1	
6-1	0223300172	RUBBER SEAL	1	
7	8211323103	CLAMPER	1	
7-1	0221200440	RUBBER SEAL	1	
8	0010110035	HEX. HEAD BOLT	2	
9	0041210000	PLAIN WASHER	2	
10	8211324003	COVER	1	
10-1	0226000303	RUBBER SEAL	2	
10-2	0225000590	RUBBER SEAL	1	
11	0017106016	HEX. HEAD BOLT	6	
12	8201315102	END BRACKET	1	
13	8201350003	FIELD ASSY. EXCITER	1	
14	0012110075	HEX. HEAD BOLT	6	
15	0042610000	LOCK WASHER	6	
16	0041210000	PLAIN WASHER	6	
17	0845044904	GROMMET	1	
18	0010112045	HEX. HEAD BOLT	8	
19	0040012000	LOCK WASHER	8	

# DCA-400SPK GENERATOR ASSY.

GENERATOR ASSY.



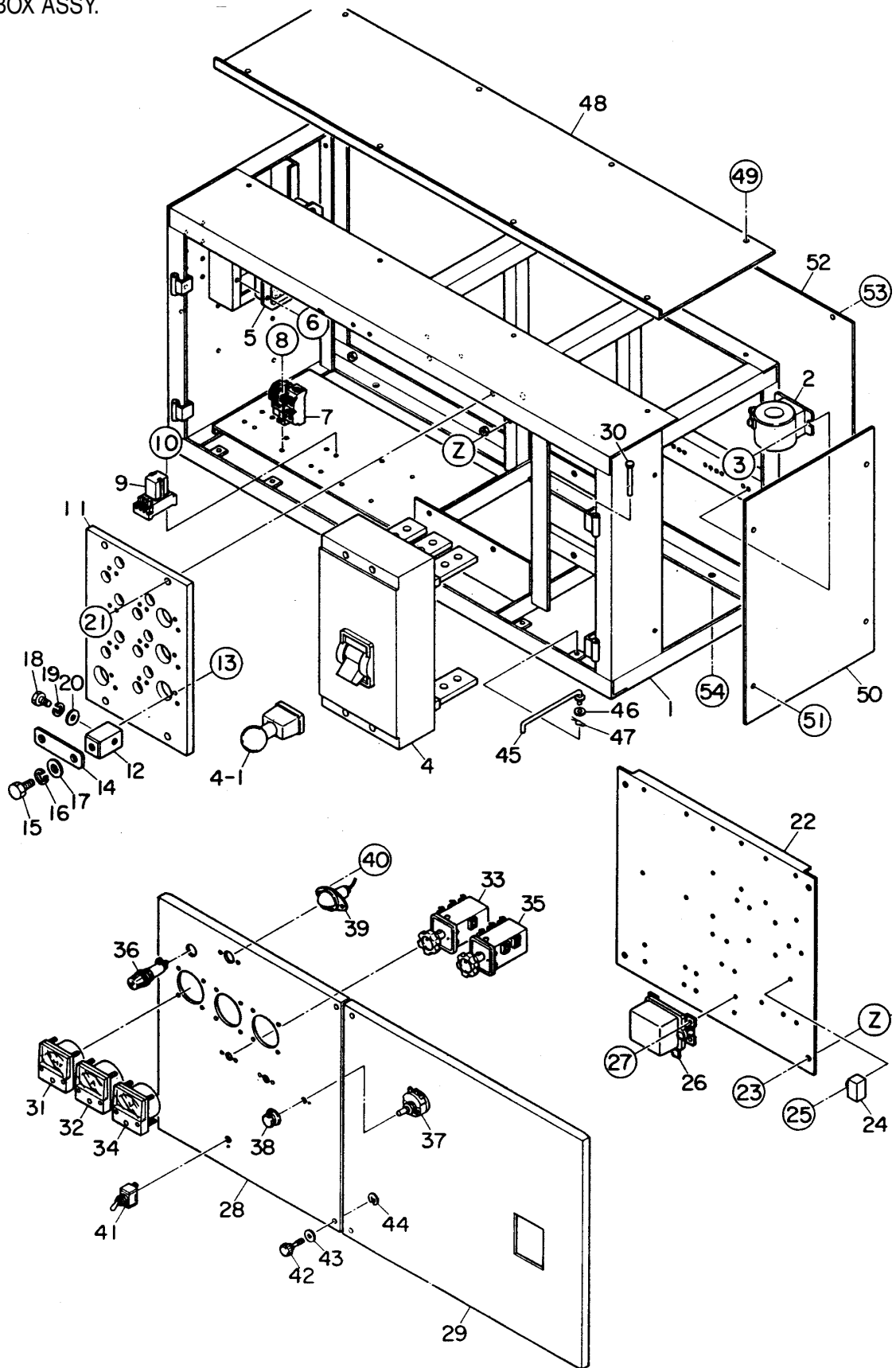
# DCA-400SPK GENERATOR ASSY.

## GENERATOR ASSY.

<u>NO.</u>	<u>PART NO.</u>	<u>PART NAME</u>	<u>QTY.</u>	<u>REMARKS</u>
20	0041212000	PLAIN WASHER	8	
21	8201310014	COVER, BEARING	1	
22	8201312014	GASKET, BEARING	1	
23	0010106065	HEX. HEAD BOLT	6	
24	0040006000	LOCK WASHER	6	
25	0041206000	PLAIN WASHER	6	
26	8171331013	COVER, END BRACKET	1	
27	0017106012	HEX. HEAD BOLT	6	
28	8171333003	COVER, END BRACKET	1	
29	0010106030	HEX. HEAD BOLT	2	
30	0040006000	LOCK WASHER	2	
31	0041206000	PLAIN WASHER	2	
32	0012112035	HEX. HEAD BOLT	16	
33	0042512000	LOCK WASHER	16	
34	8201332003	COVER, FAN	1	
35	0605000012	RUBBER SUSPENSION	4	
36	0030020000	HEX. NUT	8	
	0040020000	LOCK WASHER	8	

# DCA-400SPK CONTROL BOX ASSY.

CONTROL BOX ASSY.





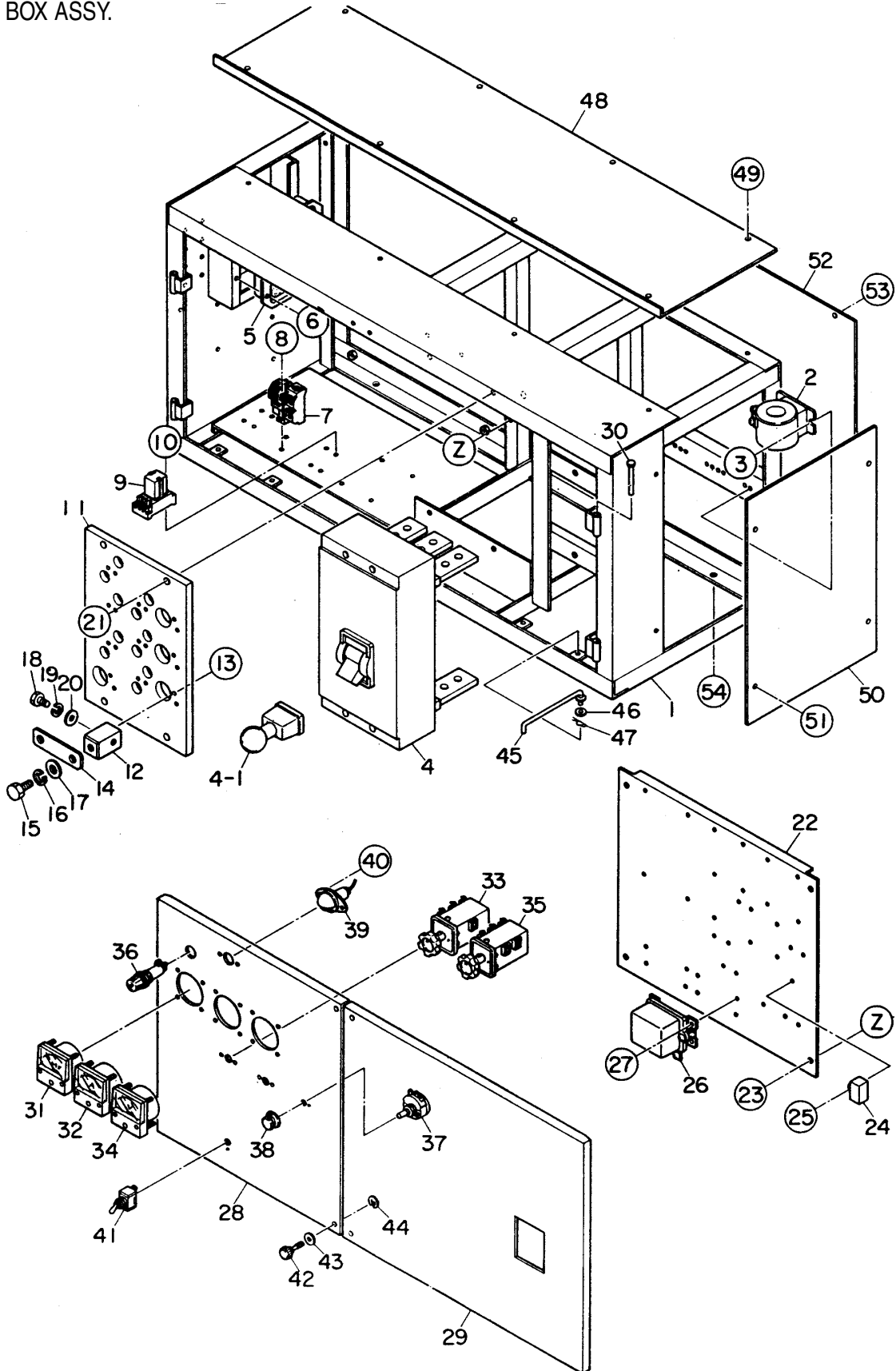
# DCA-400SPK CONTROL BOX ASSY.

## CONTROL BOX ASSY.

<u>NO</u>	<u>PART NO</u>	<u>PART NAME</u>	<u>QTY.</u>	<u>REMARKS</u>
1	8221812812	C ONTROL BOX	1	
2	0601801170	CURRENT TRANSFORMER, AMMETER .	3	..... CW5L 750/5A
3	0027106016	MACHINE SCREW	6	
4	0601805771	CIRCUIT BREAKER .....	1	..... TO1000B 1000A
4-1	0601802522	HANDLE, CIRCUIT BREAKER	1	
5	0601820625	AUTOMATIC VOLTAGE REGULATOR .....	1	..... NTA5A2T
6	0027105012	MACHINE SCREW	4	
7	0601820853	OVERCURRENT RELAY .....	1	..... THK20KP
8	0027104016	MACHINE SCREW	2	
9	0601823757	RELAY .....	2	..... MY2DC24V
	0601823143	SOCKET .....	2	..... PYF08A
	PYCA1	HOLDER .....	2	..... REPLACES0601824400
10	0027104016	MACHINE SCREW	4	
11	8221861103	SET BOARD, CHANGE TERMINAL	1	
12	8221852104	CHANGE TERMINAL	10	
13	0017108030	HEX.HEAD BOLT	20	
14	8221853104	CHANGE PLATE	6	
15	0801830804	HEX. HEAD BOLT	10	
16	0040016000	LOCK WASHER	10	
17	0041416000	PLAIN WASHER	10	
18	0801830704	HEX. HEAD BOLT	16	
19	0040012000	LOCK WASHER	16	
20	0041412000	PLAIN WASHER	16	
21	0010010035	HEX. HEAD BOLT	4	
	0040010000	LOCK WASHER	4	
	0041210000	PLAIN WASHER	4	
22	8221833403	SET PANEL, ELECTRIC PARTS	1	
23	0017108020	HEX HEAD BOLT	4	
24	0602201911	UNIT, BATTERY SENSOR .....	1	..... C7038A0000
25	0027106016	MACHINE SCREW	1	
26	0602200446	EMERGENCY RELAY .....	1	..... 6008151252
27	0017106016	HEX. HEAD BOLT	4	
28	9039211273	CONTROL PANEL	1	
29	8221822503	CONTROL PANEL	1	

# DCA-400SPK CONTROL BOX ASSY.

CONTROL BOX ASSY.



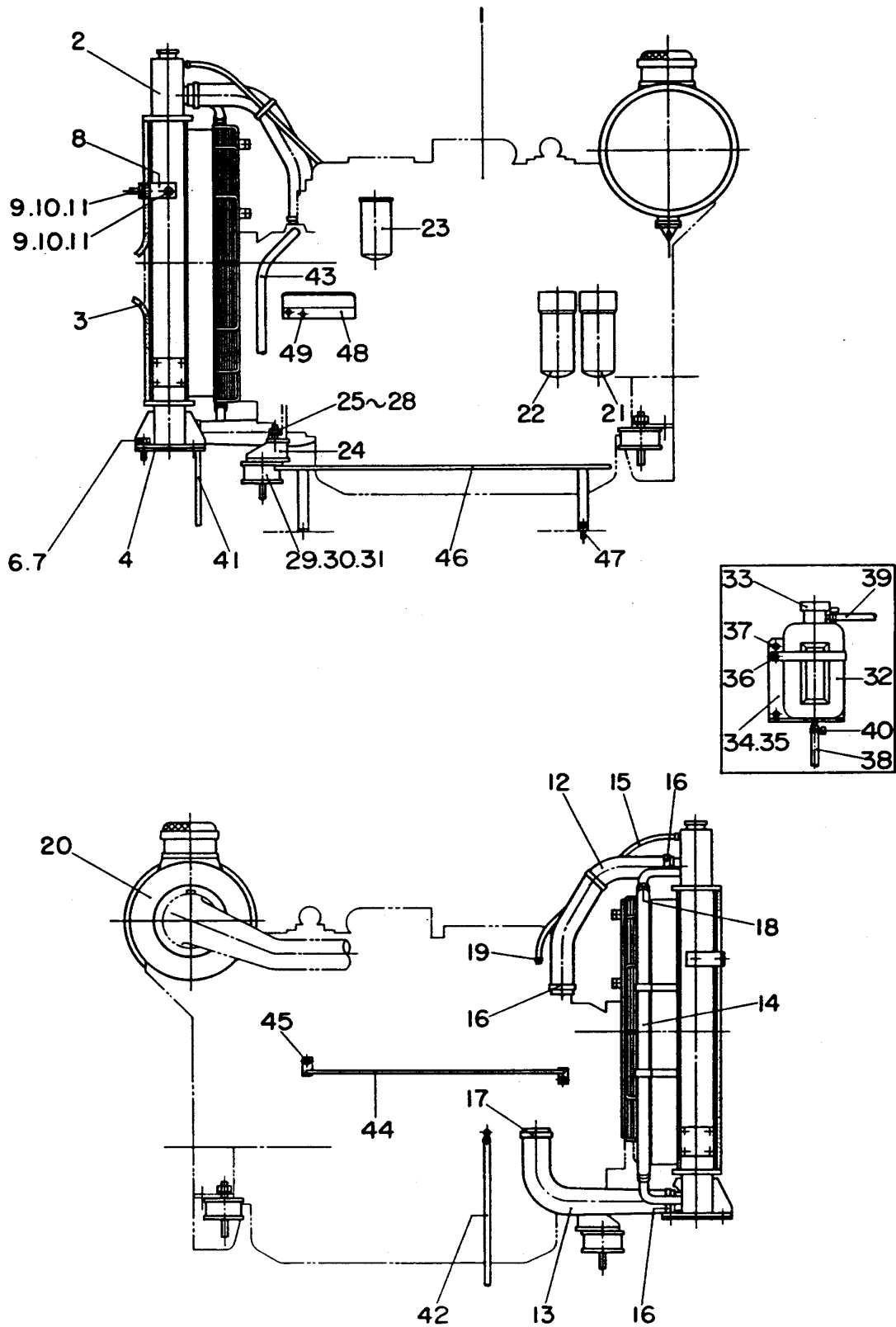
# DCA-400SPK CONTROL BOX ASSY.

## CONTROL BOX ASSY.

<u>NO</u>	<u>PART NO</u>	<u>PART NAME</u>	<u>QTY.</u>	<u>REMARKS</u>
30	0605011211	PIN	4	
31	0601800470	FREQUENCY METER .....	1	PAK80 220V 45~65Hz
32	0601805750	AC AMMETER .....	1	PSK60 0~750A 0~1500A
33	0601801040	CHG.OVER SWITCH,AMMETER .....	1	SL2AS
34	0601800233	AC VOLTMETER .....	1	PCK80 0~600V
35	0601801041	CHG.OVER SWITCH, VOLTMETER .....	1	SL2VS
36	0601810072	PILOT LAMP	1	
	0601810261	BULB	1	
37	060184073	RHEOSTAT .....	1	RA20A2SE102BJ
38	0601840121	KNOB	1	
39	0601810161	PANEL LIGHT	1	
	0601810214	BULB	1	
40	0207004000	HEX. NUT	2	
41	0601830710	SWITCH, PANEL LIGHT .....	1	S301T
42	0805001304	SET PANEL	4	
43	0041208000	PLAIN WASHER	4	
44	0605010710	SNAP RING	4	
45	3871824004	STOPPER, CONTROL PANEL	2	
46	0041206000	PLAIN WASHER	2	
47	0605010502	SNAP PIN	2	
48	8221814704	COVER, CONTROL BOX	1	
49	0017108020	HEX.HEAD BOLT	8	
50	8221826904	SIDE PANEL, CONTROL BOX	1	
51	0017108020	HEX. HEAD BOLT	4	
52	8221827704	PANEL, CONTROL BOX	1	
53	0017108020	HEX.HEAD BOLT	8	
54	0010010035	HEX. HEAD BOLT	4	
	0030010000	HEX. NUT	4	
	0040010000	LOCK WASHER	4	
	0041210000	PLAIN WASHER	8	

# DCA-400SPK ENGINE & RADIATOR ASSY.

ENGINE & RADIATOR ASSY.



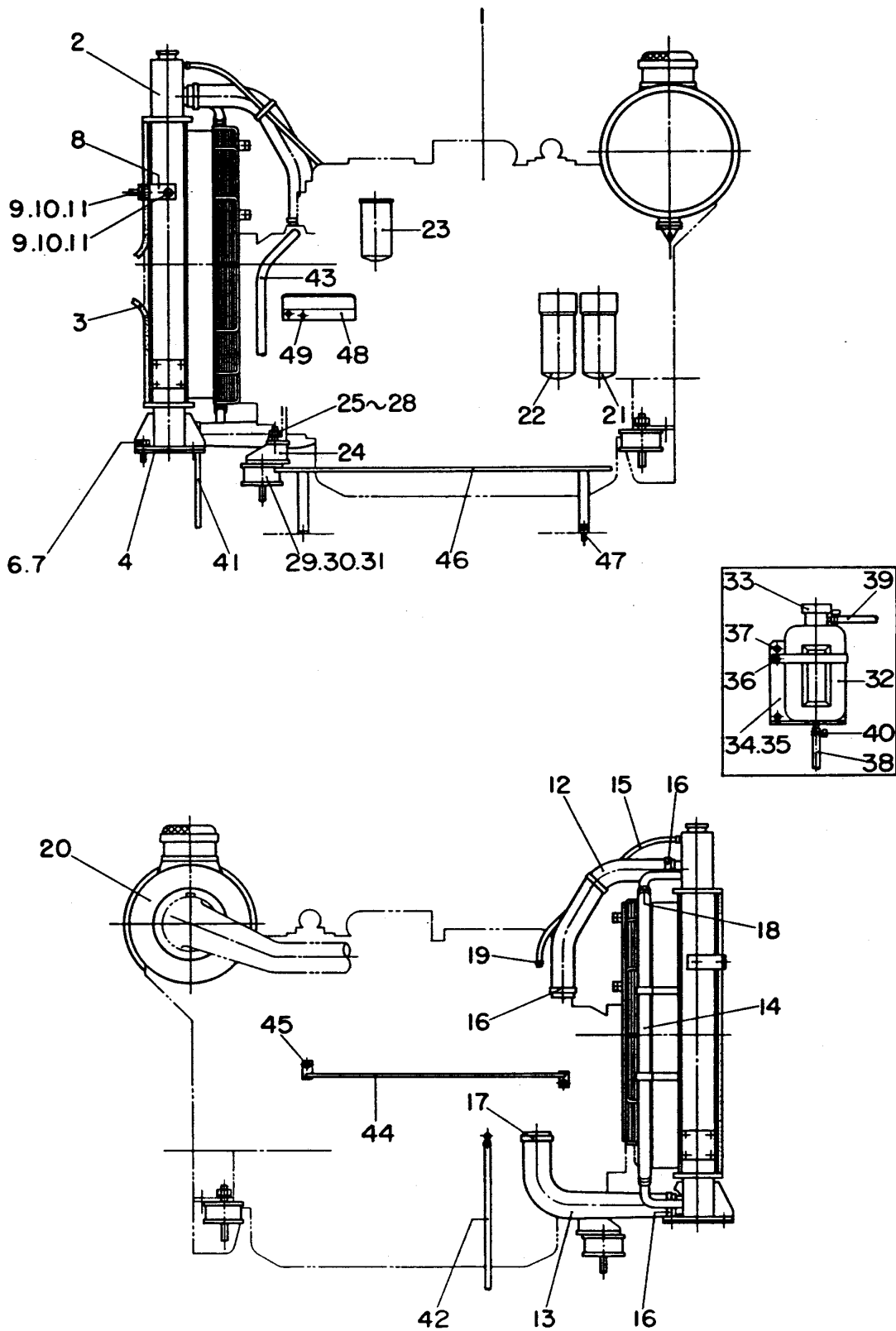
# DCA-400SPK ENGINE & RADIATOR ASSY.

## ENGINE & RADIATOR ASSY.

<u>NO.</u>	<u>PART NO.</u>	<u>PART NAME</u>	<u>QTY.</u>	<u>REMARKS</u>
1	8210150104	ENGINE .....	1 .....	SA6D140A
2	6212619900	RADIATOR .....	1 .....	REPLACES 0602011885
3	8215103504	RUBBER SEAL	1	
4	6995619230	RUBBER SHEET .....	2 .....	REPLACES 0605000085
5	0010120055	HEX. HEAD BOLT	4	
6	0040020000	LOCK WASHER	4	
7	0041220000	PLAIN WASHER	4	
8	8215123004	BRACKET, RADIATOR	2	
9	0010112025	HEX. HEAD BOLT	4	
10	0040012000	LOCK WASHER	4	
11	0041212000	PLAIN WASHER	4	
12	6212619610	RADIATOR HOSE .....	1 .....	REPLACES 0602013962
13	6212619630	RADIATOR HOSE .....	1 .....	REPLACES 0602014467
14	0726102612	RADIATOR HOSE .....	1 .....	REPLACES 0602013963
15	6212619650	RADIATOR HOSE .....	1 .....	REPLACES 0602013964
16	0728100909	HOSE BAND .....	3 .....	REPLACES 0602014056
17	0728101029	HOSE BAND .....	1 .....	REPLACES 0602014350
18	0728100489	HOSE BAND .....	2 .....	REPLACES 0602014351
19	0728100167	HOSE BAND .....	2 .....	REPLACES 0602014059
20	6128817051	ELEMENT, AIR CLEANER .....	1 .....	REPLACES 0602040157
21	6002111230	CARTRIDGE, OIL FILTER .....	1 .....	REPLACES 0602041146
22	6003117130	CARTRIDGE, FUEL FILTER .....	1 .....	REPLACES 0602042157
23	6004111170	CARTRIDGE, CORROSION RESISTOR .....	1 .....	REPLACES 0602045144
24	8215112203	ENGINE FOOT	1	
25	0010118060	HEX. HEAD BOLT	2	
26	0030018000	HEX. NUT	2	
27	0040018000	LOCK WASHER	2	
28	0041218000	PLAIN WASHER	4	
29	0605000012	RUBBER SUSPENSION	4	
30	0030020000	HEX. NUT	8	
31	0040020000	LOCK WASHER	8	
32	0802081003	RESERVE TANK	1	

# DCA-400SPK ENGINE & RADIATOR ASSY.

ENGINE & RADIATOR ASSY.



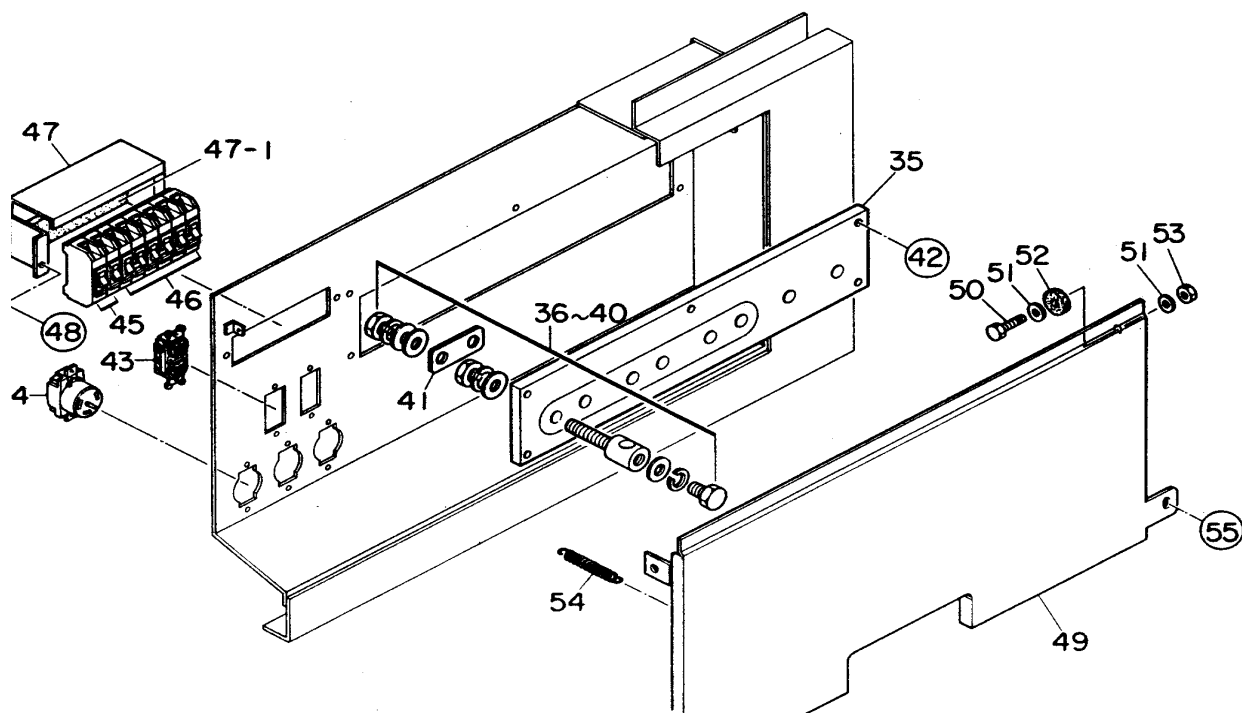
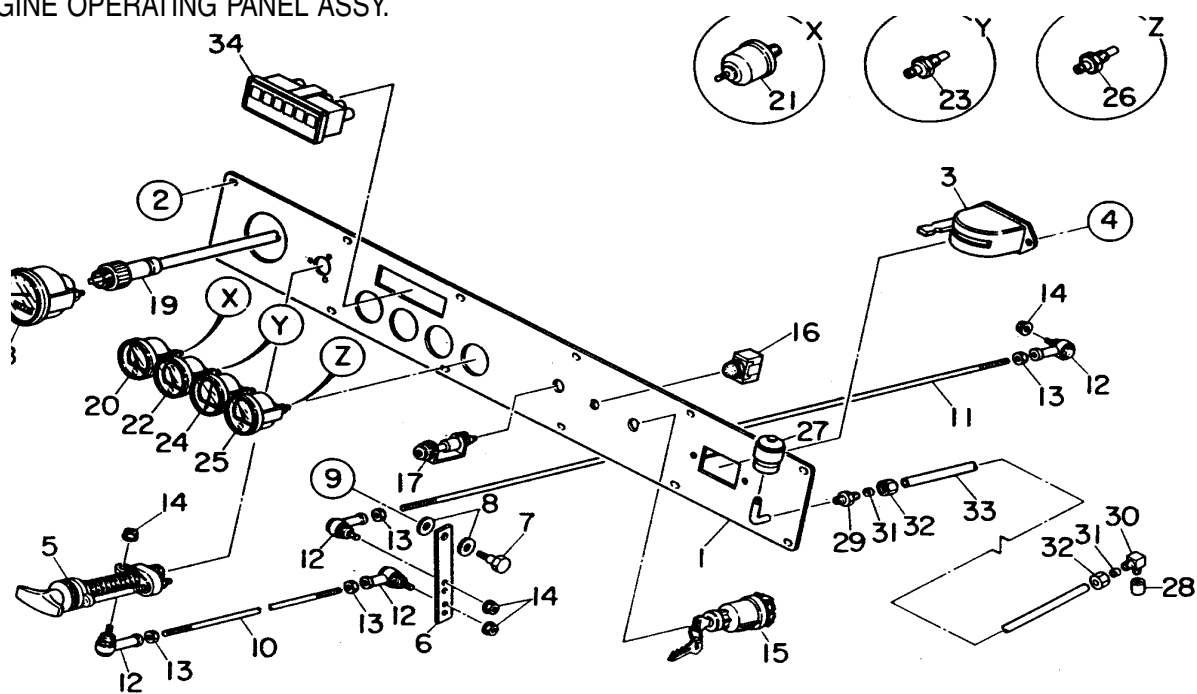
# DCA-400SPK ENGINE & RADIATOR ASSY.

## ENGINE & RADIATOR ASSY.

<u>NO.</u>	<u>PART NO.</u>	<u>PART NAME</u>	<u>QTY.</u>	<u>REMARKS</u>
33	0602010900	CAP, RESERVE TANK	1	
34	8212082103	BRACKET, RESERVE TANK	1	
35	0229200600	RUBBER CUSHION	1	
36	0017106025	HEX. HEAD BOLT	1	
37	0017108020	HEX. HEAD BOLT	2	
38	0199601150	HOSE	1	
39	0193601300	HOSE	1	
40	0605515024	HOSE BAND	2	
41	0194700400	HOSE	1	
42	0194700450	HOSE	1	
43	0198501050	HOSE	1	
44	3972220103	SUPPORT ROD	1	
45	0017110025	HEX. HEAD BOLT	2	
46	8212256104	SUPPORT ROD	1	
47	0019208020	HEX. HEAD BOLT	2	
48	8212044103	OIL PANEL	1	
49	0017110025	HEX. HEAD BOLT	2	

# DCA-400SSKENGINE OPERATING PANEL ASSY.

ENGINE OPERATING PANEL ASSY.





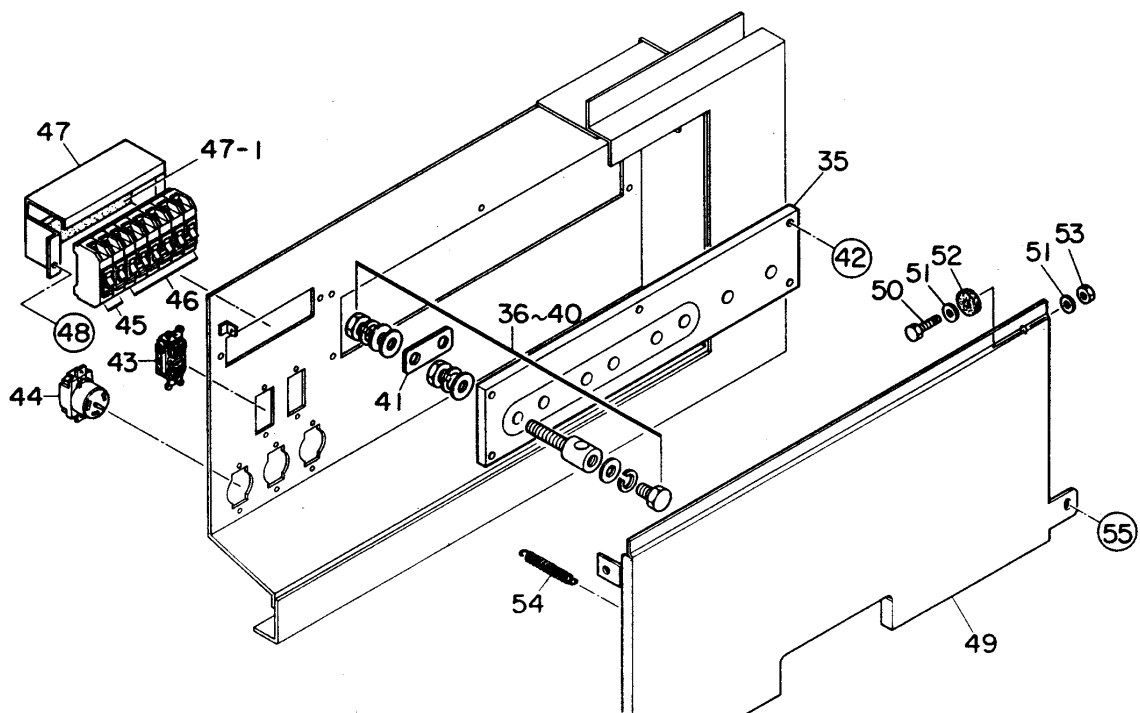
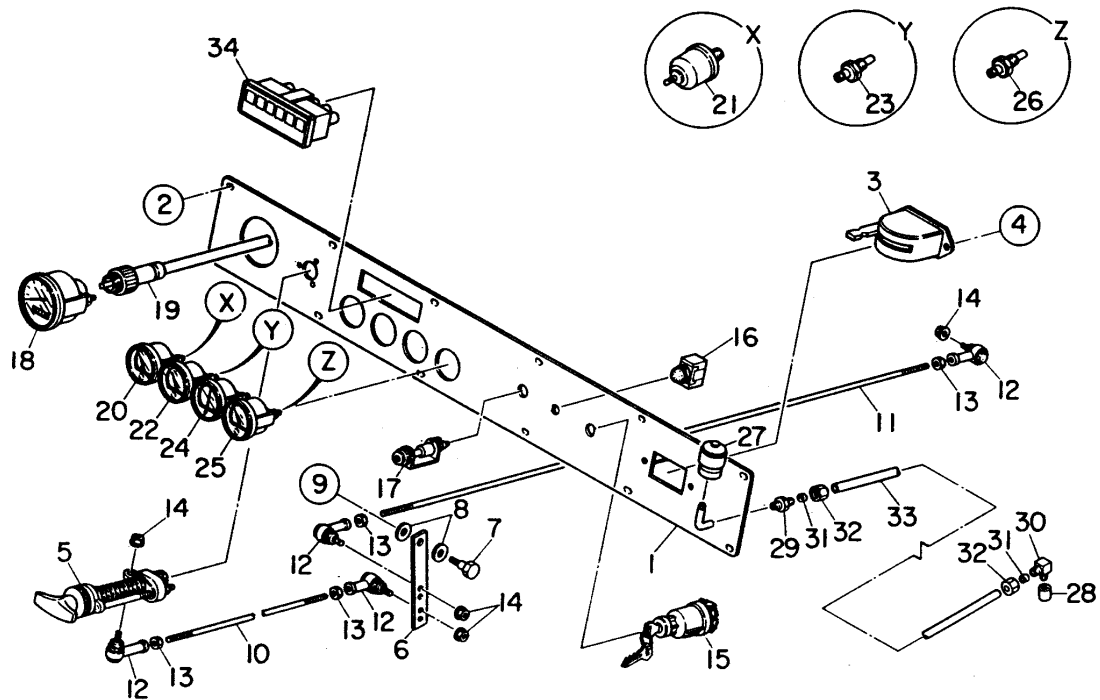
# DCA-400SPK ENGINE OPERATING PANEL ASSY.

## ENGINE OPERATING PANEL ASSY.

<u>NO</u>	<u>PART NO</u>	<u>PART NAME</u>	<u>QTY.</u>	<u>REMARKS</u>
1	9039211283	OPERATING PANEL	1	
2	0017106016	HEX. HEAD BOLT	12	
3	0602101000	BATTERY SWITCH	1	9827300090
4	0021008080	MACHINE SCREW	2	
	0030008000	HEX. NUT	2	
	0040008000	LOCK WASHER	2	
	00412080000	PLAIN WASHER	2	
5	0840201200	THROTTLE HANDLE`	1	
6	08212183004	LINK, GOVERNOR ROD	1	
7	0845045604	PIN BOLT	1	
8	0042412000	PLAIN WASHER	20	
9	0205008000	HEX. NUT	1	
	0042308000	LOCK WASHER	1	
	0042408000	PLAIN WASHER	2	
10	8212152004	GOVERNOR ROD	1	
11	8212152104	GOVERNOR ROD	1	
12	0602180106	BALL JOINT	4	
13	0030008000	HEX. NUT	4	
14	0207006000	HEX. NUT	4	
15	0602100049	STARTER SWITCH	1	6008155390
16	0601804045	STOP BUTTON	1	0806410000
17	0602102055	PREHEAT INDICATOR	1	6008153730
18	0602120054	TACHOMETER	1	25000KX4110
19	0602120156	CABLE, TACHOMETER	1	62500KA4210 L=3000
20	0602122053	OIL PRESSURE GAUGE	1	42000KV0300
21	0602122200	UNIT, OIL PRESSURE	1	53000AC0101
22	0602123053	WATER TEMPERATURE GAUGE	1	4000KV0700
23	0602123206	UNIT, WATER TEMPERATURE	1	51000KS0600
24	0602121052	CHARGING AMMETER	1	43000KV0300
25	0602124053	OIL TEMPERATURE GAUGE	1	40000KV0800
26	0602123206	UNIT, OIL TEMPERATURE	1	51400KS0600
27	0602040690	INDICATOR, AIR CLEANER	1	RBX002252
28	6203306104	SOCKET	1	
29	0603300000	HALF UNION	1	
30	0603301000	ELBOW UNION	1	
31	0603302000	SLEEVE	2	
32	0603303000	NUT	2	
33	0190001600	NYLON PIPE	1	
34	0602115008	OK MONITOR	1	V33676A
	0601810204	BULB	6	
35	8221860203	SET BOARD, OUTPUT TERMINAL	1	
36	0801830404	OUTPUT TERMINAL	8	
37	0801830904	HEX. HEAD BOLT	8	
38	0039320000	HEX. NUT	16	
39	0040020000	LOCK WASHER	24	

# DCA-400SSKENGINE OPERATING PANEL ASSY.

ENGINE OPERATING PANEL ASSY.



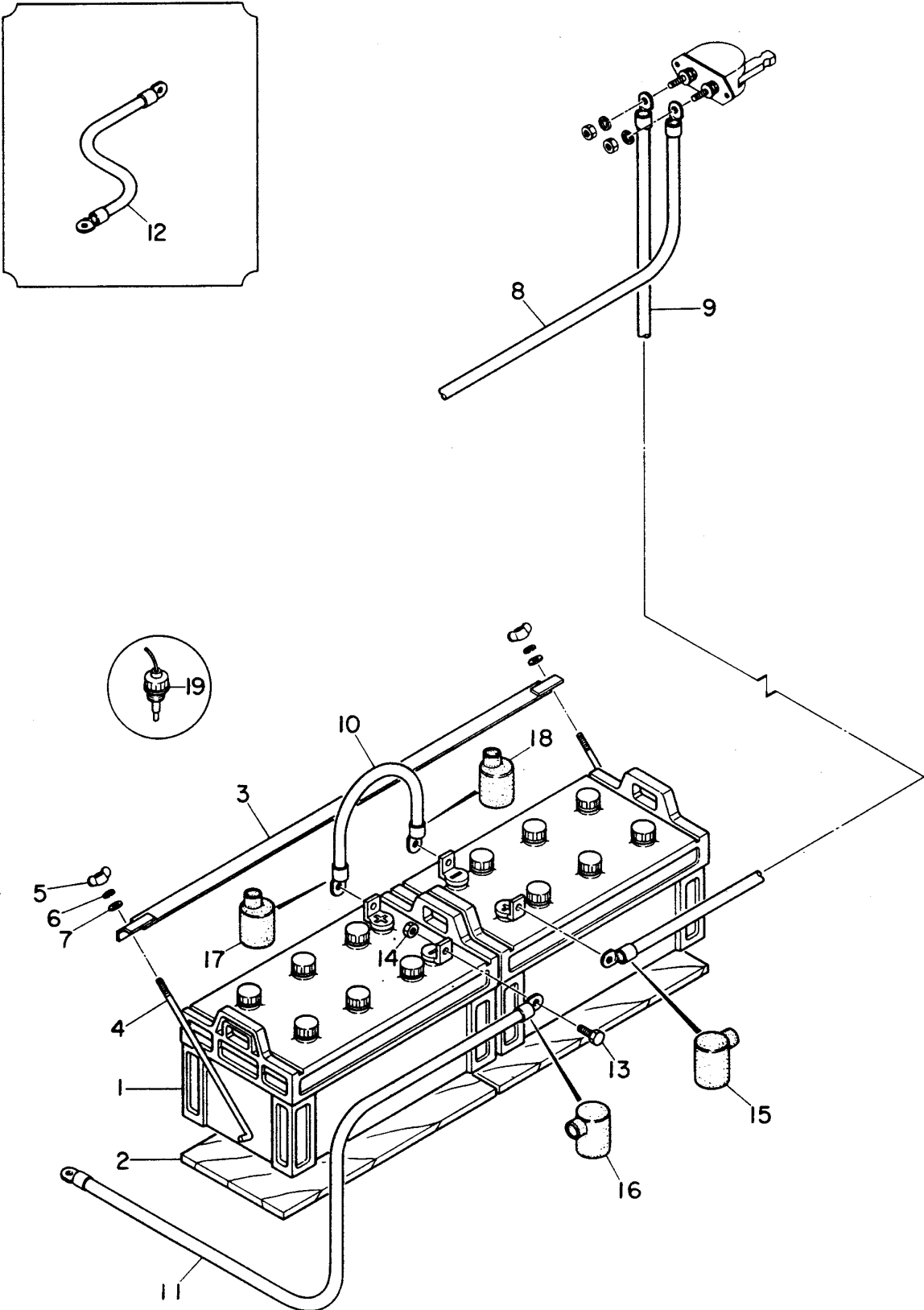
# DCA-400SPK ENGINE OPERATING PANEL ASSY.

## ENGINE OPERATING PANEL ASSY.

<u>NO</u>	<u>PART NO</u>	<u>PART NAME</u>	<u>QTY.</u>	<u>REMARKS</u>
40	0041420000	PLAIN WASHER	32	
41	3501860604	TERMINAL PLATE	3	
42	0019110040	HEX. HEAD BOLT	5	
	0042310000	LOCKWASHER	5	
	0042410000	PLAIN WASHER	5	
43	0601812597	RECEPTACLE, AUX. POWER	2	5-20R GF5352
44	0601811034	RECEPTACLE, AUX. POWER	3	CS6369
45	0601805313	CIRCUIT BREAKER	2	KM51 20A
46	0601805840	CIRCUIT BREAKER	3	KM52 50A
47	8211834203	BRACKET, CIRCUIT BREAKER	1	
47-1	0223300200	RUBBER CUSHION	1	
48	0019106035	HEX. HEAD BOLT	2	
	0042306000	LOCKWASHER	2	
	0042406000	PLAIN WASHER	2	
49	8215082003	COVER, OUTPUT TERMINAL	1	
50	0019112045	HEX. HEAD BOLT	2	
51	0042412000	PLAIN WASHER	4	
52	0805009804	RUBBER WASHER	2	
53	0205012000	HEX. NUT	2	
54	0845043704	SPRING	2	
55	0019208020	HEX. HEAD BOLT	2	

# DCA-400SPK — BATTERY ASSY.

BATTERY ASSY.

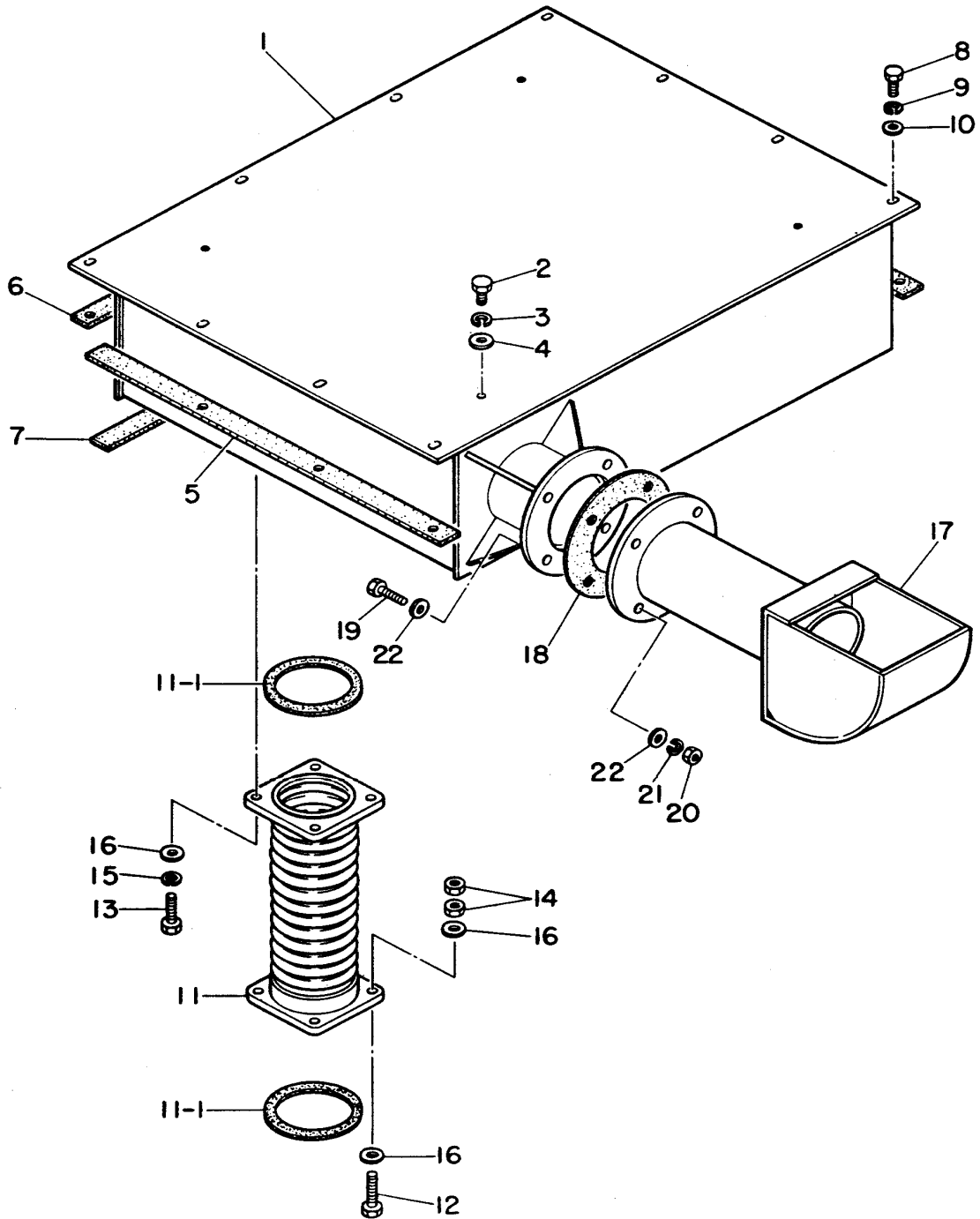


## BATTERY ASSY.

<b><u>NO.</u></b>	<b><u>PART NO.</u></b>	<b><u>PART NAME</u></b>	<b><u>QTY.</u></b>	<b><u>REMARKS</u></b>
1	0168719052	BATTERY	2	
2	0805018904	BATTERY SHEET	2	
3	0805006404	BATTERY BAND	1	
4	0805006504	BATTERY BOLT	2	
5	0037808000	WING NUT	2	
6	0040008000	LOCK WASHER	2	
7	0041208000	PLAIN WASHER	2	
8	8212265304	BATTERY CABLE	1	
9	8212265104	BATTERY CABLE	1	
10	6212265504	BATTERY CABLE	1	
11	8212265704	BATTERY CABLE	1	
12	8212265904	EARTH CABLE	1	
13	0010010030	HEX. HEAD BOLT	4	
14	0030010000	HEX. NUT	4	
15	0845040114	TERMINAL CAP	1	
16	0845041004	TERMINAL CAP	1	
17	0845040214	TERMINAL CAP	1	
18	0845041104	TERMINAL CAP	1	
19	0602220205	BATTERY SENSOR	1	

# DCA-400SPK — MUFFLER ASSY.

MUFFLER ASSY.



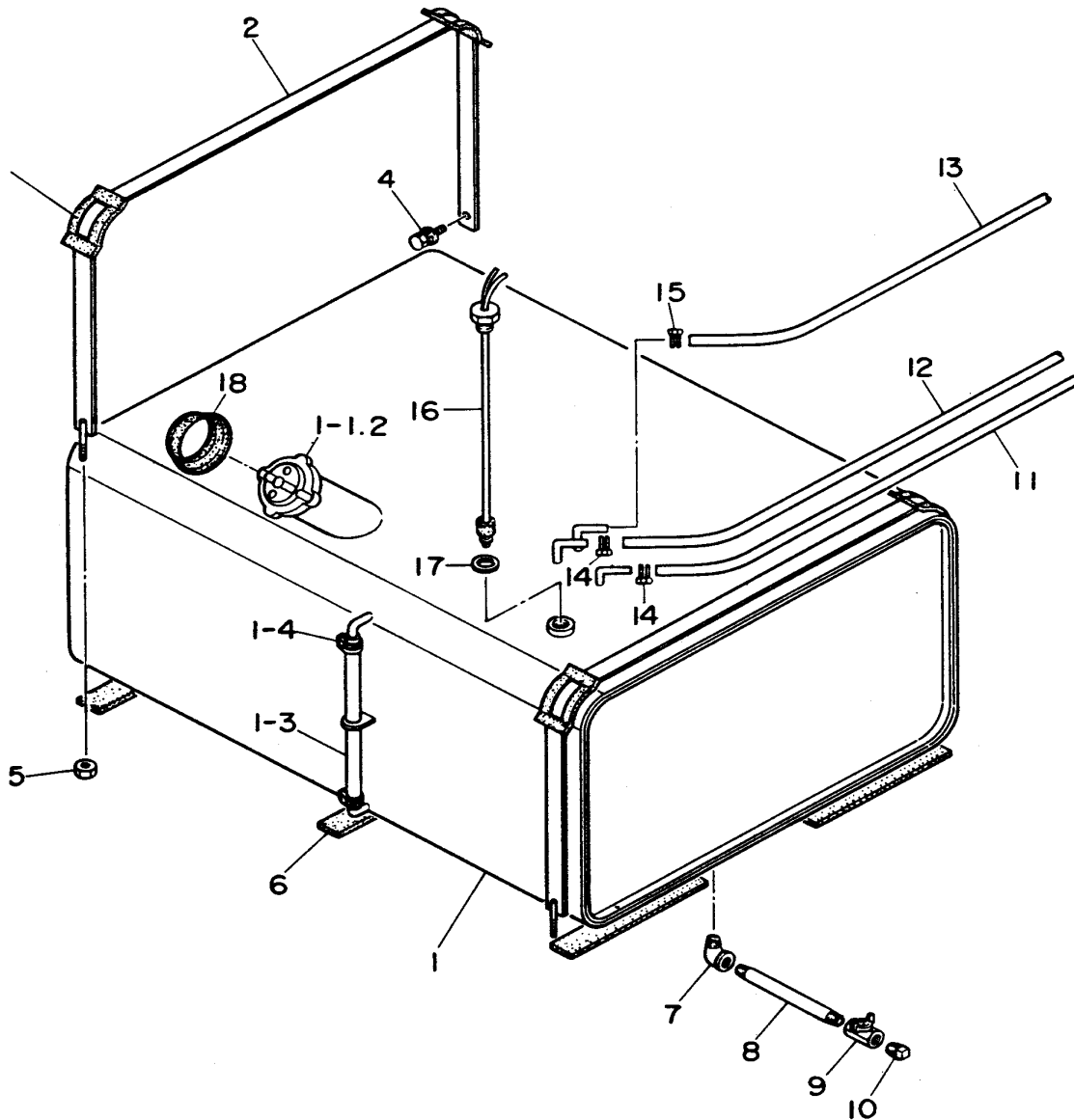
# DCA-400SPK — MUFFLER ASSY.

## MUFFLER ASSY.

<u>NO.</u>	<u>PART NO.</u>	<u>PART NAME</u>	<u>QTY.</u>	<u>REMARKS</u>
1	8212311002	MUFFLER	1	
2	0019112025	HEX. HEAD BOLT	4	
3	0042312000	LOCK WASHER	4	
4	0042412000	PLAIN WASHER	4	
5	8212356004	PACKING	2	
6	8222356104	PACKING	1	
7	8222356204	PACKING	1	
8	0019110030	HEX. HEAD BOLT	10	
9	0042310000	LOCK WASHER	10	
10	0042410000	PLAIN WASHER	10	
11	8212350003	EXHAUST PIPE	1	
11-1	0602320095	GASKET	2	
12	0010312060	HEX. HEAD BOLT	4	
13	0010312030	HEX. HEAD BOLT	4	
14	0030312000	HEX. NUT	8	
15	0040012000	LOCK WASHER	4	
16	0041212000	PLAIN WASHER	12	
17	8212355003	OUTLET PIPE	1	
18	7432356104	GASKET	1	
19	0019112050	HEX. HEAD BOLT	4	
20	0030012000	HEX. NUT	4	
21	0042312000	LOCK WASHER	4	
22	0042412000	PLAIN WASHER	8	

# DCA-400SPK — FUEL TANK ASSY.

FUEL TANK ASSY.



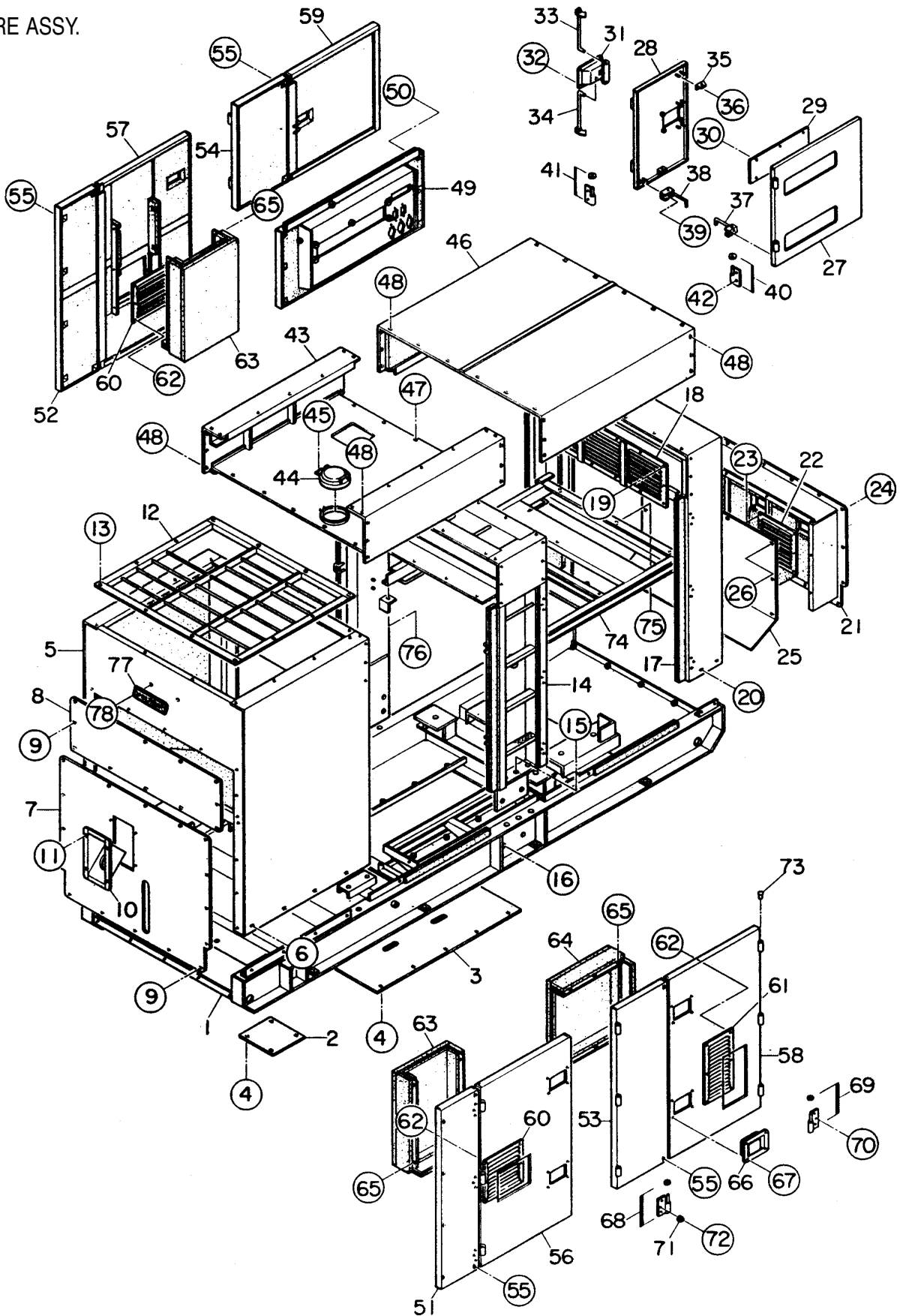


## FUEL TANK ASSY.

<b><u>NO.</u></b>	<b><u>PART NO.</u></b>	<b><u>PART NAME</u></b>	<b><u>QTY.</u></b>	<b><u>REMARKS</u></b>
1	8215510503	FUEL TANK	1	
1-1	0845500104	CAP, FUEL TANK	1	
1-2	0810105400	FUEL FILTER	1	
1-3	0264100390	HOSE, FUEL GAUGE	1	
1-4	0605515079	HOSE BAND	2	
2	8225523104	TANK BAND	2	
3	0805003414	PAD, TANK BAND	4	
4	0017108020	HEX. HEAD BOLT	2	
5	0037908000	HEX. NUT	2	
6	0222100300	TANK SHEET	6	
7	0130206000	STREET ELBOW	1	
8	3515512014	DRAIN JOINT	1	
9	0603325011	VALVE	1	
10	0132006000	PLUG	1	
11	0191302290	SUCTION HOSE	1	
12	0191302390	RETURN HOSE	1	
13	0191003750	RETURN HOSE	1	
14	0605515014	HOSE BAND	4	
15	0605515024	HOSE BAND	2	
16	0605503020	FUEL SENSOR	1	
17	0802120604	PACKING	1	
18	0845039604	RUBBER SEAL	1	

# DCA-400SPK — ENCLOSURE ASSY.

ENCLOSURE ASSY.



# DCA-400SPK — ENCLOSURE ASSY.

## ENCLOSURE ASSY.

<u>NO.</u>	<u>PART NO.</u>	<u>PART NAME</u>	<u>QTY.</u>	<u>REMARKS</u>
1	8215111022	BASE	1	
2	3515116114	FLOOR PANEL	1	
3	8215116004	FLOOR PANEL	1	
4	0019208020	HEX. HEAD BOLT	14	
5	8215020204	FRONT FRAME	1	
	8215102003	LINING	1	
6	0019110025	HEX. HEAD BOLT	8	
	0042310000	LOCK WASHER	8	
	0042410000	PLAIN WASHER	8	
7	8225125104	COVER, FRONT FRAME	1	
8	8225125204	COVER, FRONT FRAME	1	
	8225102104	LINING	1	
9	0019208020	HEX. HEAD BOLT	28	
10	0845042703	FILLER BRACKET	1	
11	0019208020	HEX. HEAD BOLT	4	
12	8215125003	COVER, FRONT FRAME	1	
13	0019208020			
14	8215131202	CENTER FRAME	1	
15	0010120070	HEX. HEAD BOLT	6	
	0030020000	HEX. NUT	6	
	0040020000	LOCK WASHER	6	
	0041220000	PLAIN WASHER	12	
16	0010120060	HEX. HEAD BOLT	8	
	0030020000	HEX. NUT	8	
	0040020000	LOCK WASHER	8	
	0041220000	PLAIN WASHER	16	
17	8215041414	REAR FRAME	1	
	8215940304	LINING	1	
18	8225151004	LOUVER PANEL	1	
19	0207006000	HEX. NUT	18	

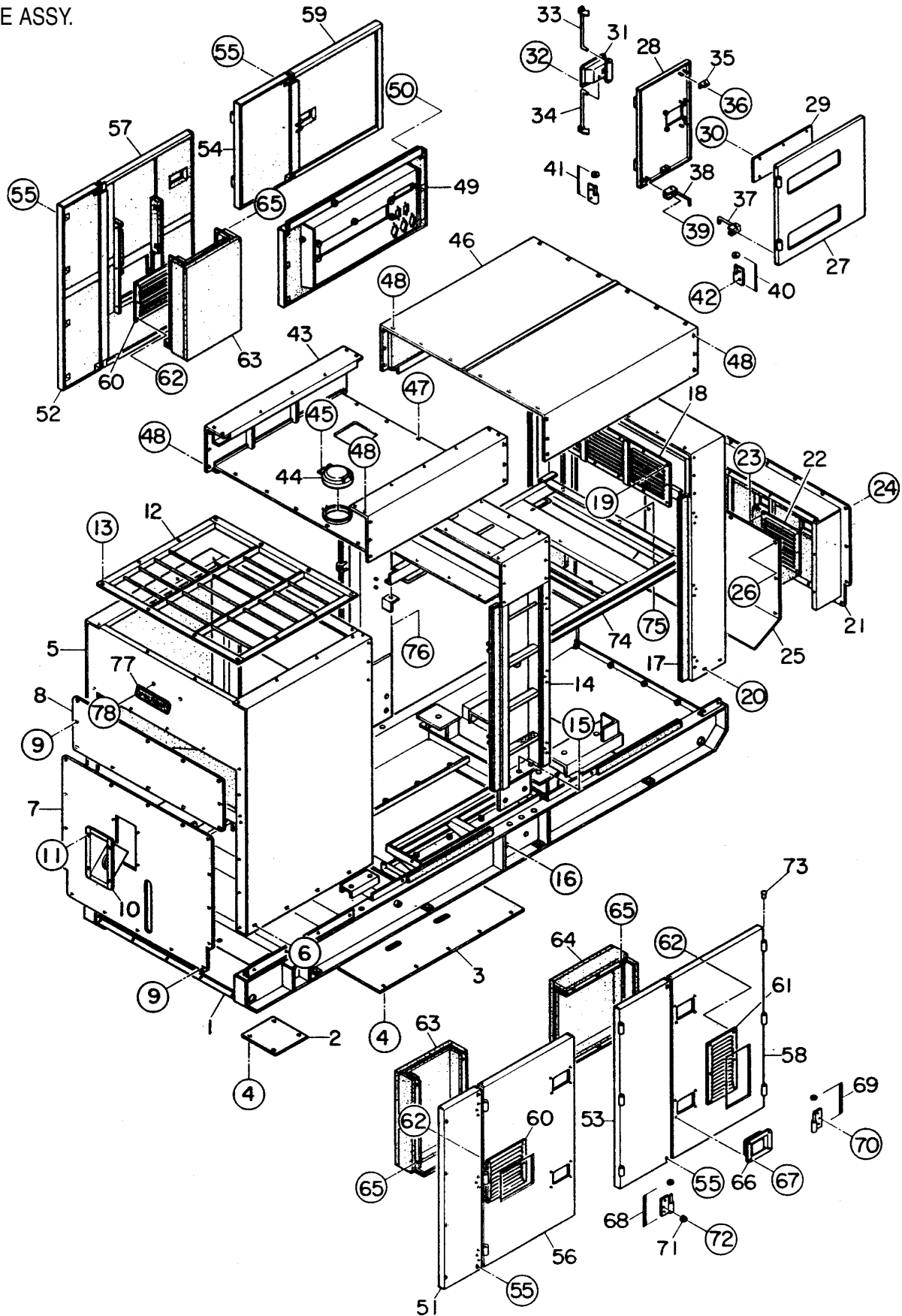
ADD THE FOLLOWING DIGITS AFTER THE PART NUMBER  
WHEN ORDERING ANY PAINTED PANEL TO INDICATE  
COLOR OF UNIT:

1-ORANGE	5-BLACK
2-WHITE	6-CATERPILLAR YELLOW
3-SPECTRUM GRAY	7-CATO GOLD
4-SUNBELT GREEN	8-RED

THE SERIAL NUMBER MAY BE REQUIRED.

# DCA-400SPK — ENCLOSURE ASSY.

ENCLOSURE ASSY.



ENCLOSURE ASSY.

<u>NO.</u>	<u>PART NO.</u>	<u>PART NAME</u>	<u>QTY.</u>	<u>REMARKS</u>
20	0019110025	HEX. HEAD BOLT	4	
	0042310000	LOCK WASHER	4	
	0042410000	PLAIN WASHER	4	
21	8215155203	COVER, REAR FRAME	1	
	8215946304	LINING	1	
22	8195151204	LOUVER PANEL	3	
23	0207006000	HEX. NUT	18	
24	0019208020	HEX. HEAD BOLT	15	
25	8215155104	DUCT COVER	1	
	8215102804	LINING	1	
26	0017108020	HEX. HEAD BOLT	12	
27	8215143503	DOOR, REAR FRAME	1	
28	8225143403	DOOR, REAR FRAME	1	
29	8225147004	WINDOW PLATE	2	
30	0037906000	HEX. NUT	12	
31	0845050804	DOOR HANDLE	1	
	0845052404	KEY, DOOR HANDLE	1	
32	0021806016	MACHINE SCREW	4	
33	8225146204	DOOR ROD	1	
34	8225146304	DOOR ROD	1	
35	0845050704	STAY	4	
36	0207006000	HEX. NUT	8	
37	0805011304	STOPPER, DOOR	1	
38	0805011204	STOPPER, DOOR	1	
39	0207006000	HEX. NUT	4	
40	0845047104	HINGE	2	
	0845045004	WASHER	2	
41	0845047204	HINGE	2	
	0845045004	WASHER	2	
42	0019208020	HEX. HEAD BOLT	6	
43	8215161002	ROOF PANEL	1	

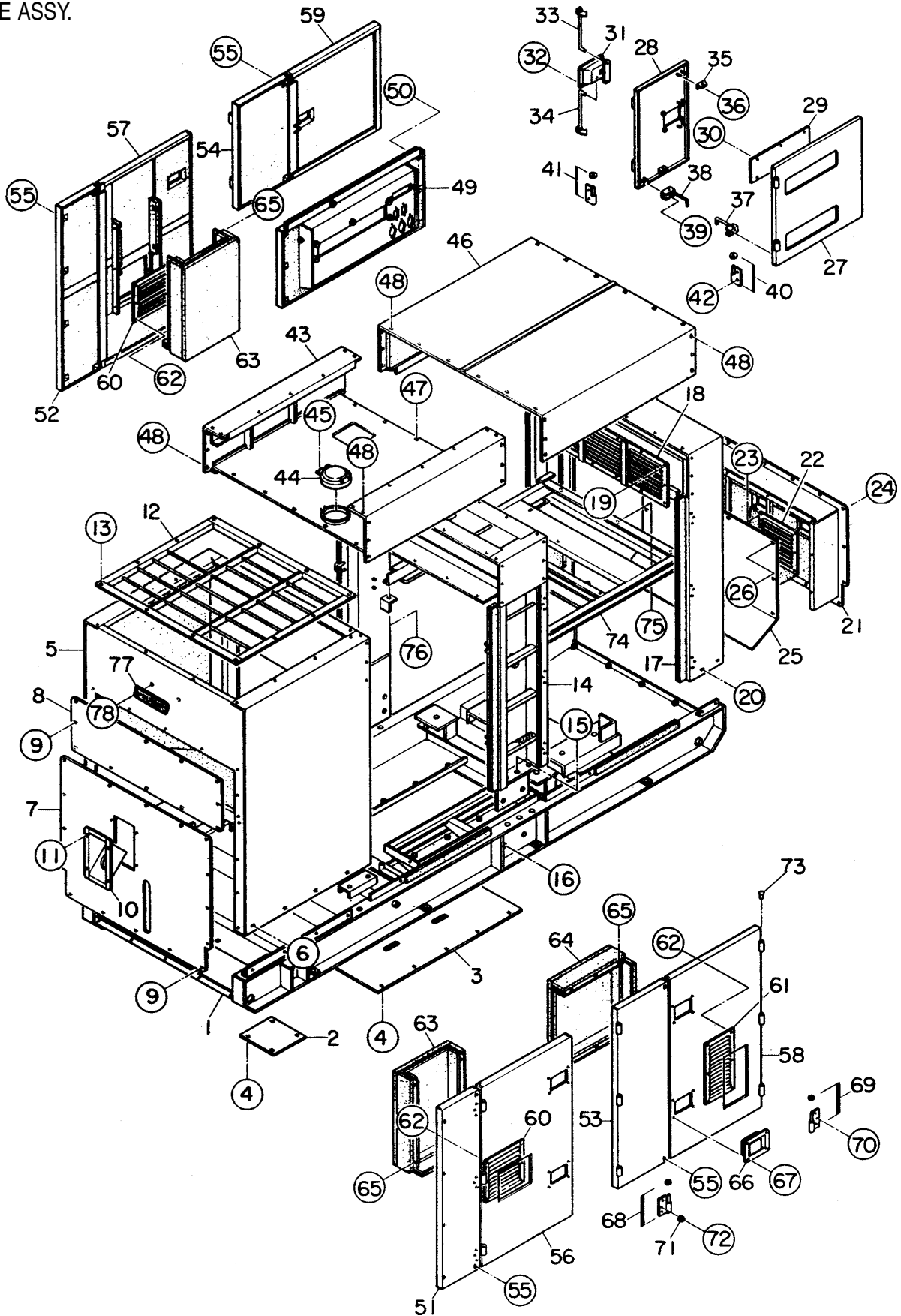
ADD THE FOLLOWING DIGITS AFTER THE PART NUMBER  
WHEN ORDERING ANY PAINTED PANEL TO INDICATE  
COLOR OF UNIT:

1-ORANGE	5-BLACK
2-WHITE	6-CATERPILLAR YELLOW
3-SPECTRUM GRAY	7-CATO GOLD
4-SUNBELT GREEN	8-RED

THE SERIAL NUMBER MAY BE REQUIRED.

# DCA-400SPK — ENCLOSURE ASSY.

ENCLOSURE ASSY.



ENCLOSURE ASSY.

<u>NO.</u>	<u>PART NO.</u>	<u>PART NAME</u>	<u>QTY.</u>	<u>REMARKS</u>
44	0800251701	FILLER COVER	1	
45	0025006016	MACHINE SCREW	2	
	0042306000	LOCK WASHER	2	
	0042406000	PLAIN WASHER	2	
46	8215161102	ROOF PANEL	1	
	8215102103	LINING	1	
47	0019208020	HEX. HEAD BOLT	10	
48	0019110025	HEX. HEAD BOLT	42	
	0042310000	LOCK WASHER	42	
	0042410000	PLAIN WASHER	42	
49	9039211263	SPLASHER PANEL	1	
	8215103204	LINING	1	
50	0019108065	HEX. HEAD BOLT	6	
	0042308000	LOCK WASHER	6	
	0042408000	PLAIN WASHER	6	
51	8215172113	SIDE PANEL	1	
	8215972904	LINING	1	
52	8215172013	SIDE PANEL	1	
	8215972904	LINING	1	
53	8215172803	SIDE PANEL	1	
	8215102404	LINING	1	
54	8215172903	SIDE PANEL	1	
	8215102303	LINING	1	
55	0019110070	HEX. HEAD BOLT	16	
	0042310000	LOCK WASHER	16	
	0042410000	PLAIN WASHER	16	
56	8215171803	SIDE DOOR	1	
	8215970903	LINING	1	
57	8215171903	SIDE DOOR	1	
	8215970903	LINING	1	
58	8215172603	SIDE DOOR	1	
	8215971104	LINING	1	
59	8215172703	SIDE DOOR	1	
	8215971304	LINING	1	

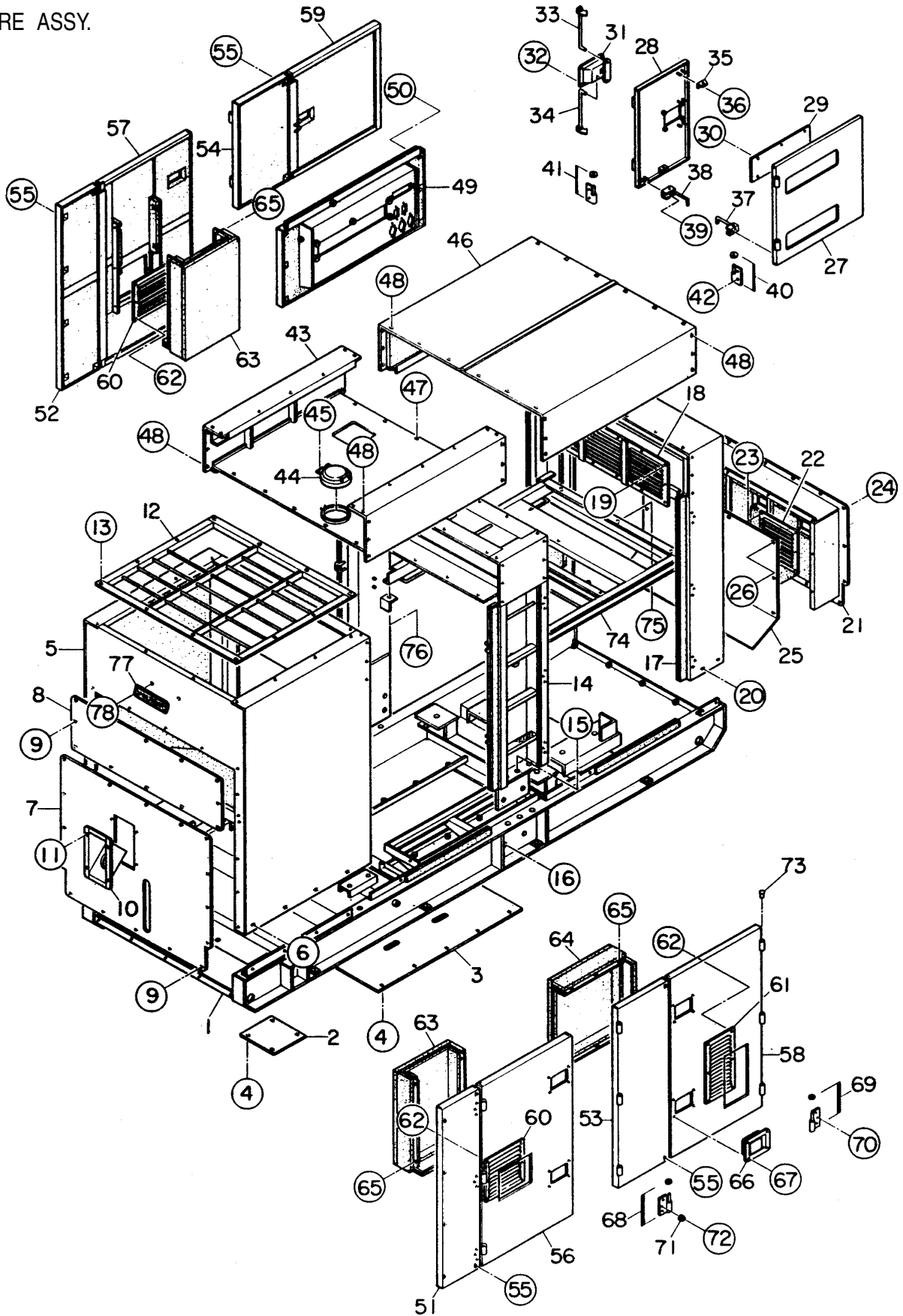
ADD THE FOLLOWING DIGITS AFTER THE PART NUMBER  
WHEN ORDERING ANY PAINTED PANEL TO INDICATE  
COLOR OF UNIT:

1-ORANGE	5-BLACK
2-WHITE	6-CATERPILLAR YELLOW
3-SPECTRUM GRAY	7-CATO GOLD
4-SUNBELT GREEN	8-RED

THE SERIAL NUMBER MAY BE REQUIRED.

# DCA-400SPK — ENCLOSURE ASSY.

ENCLOSURE ASSY.





# DCA-400SPK — ENCLOSURE ASSY.

## ENCLOSURE ASSY.

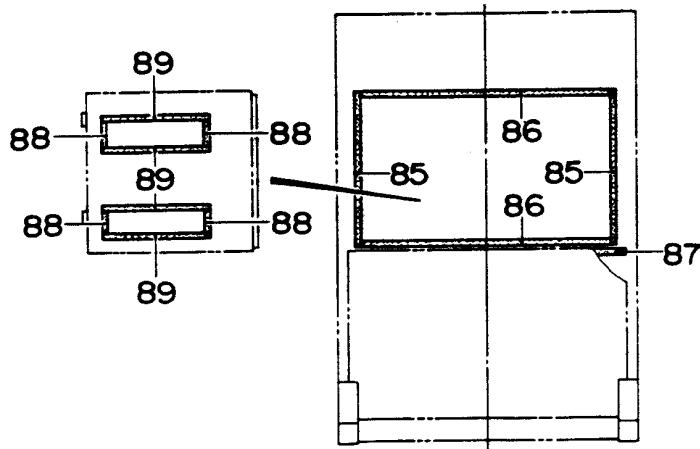
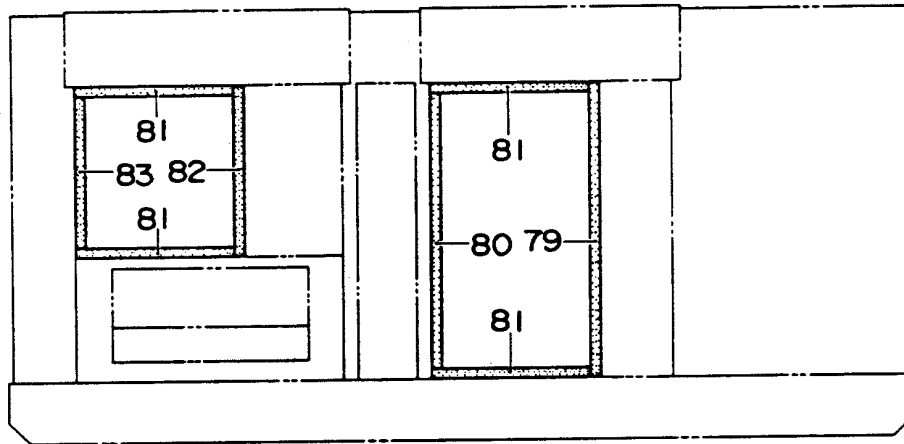
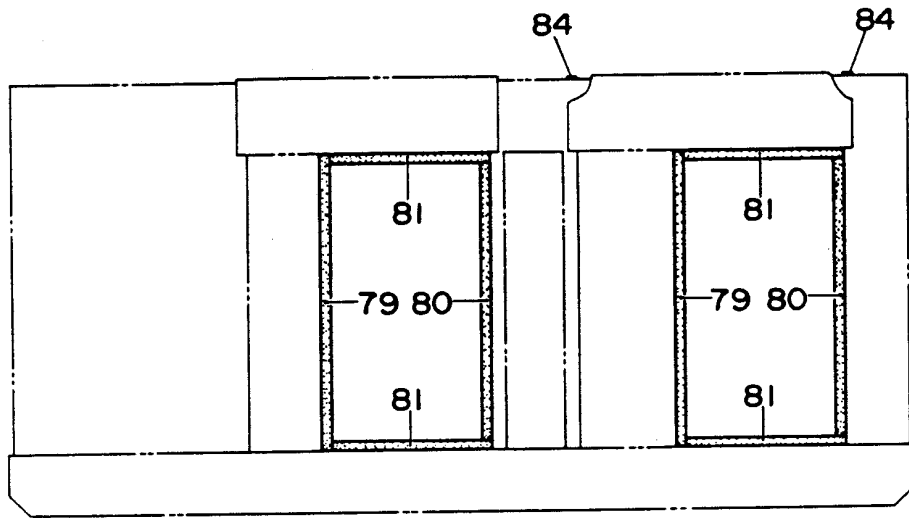
<u>NO.</u>	<u>PART NO.</u>	<u>PART NAME</u>	<u>QTY.</u>	<u>REMARKS</u>
60	8195151004	LOUVER PANEL	2	
61	8215151004	LOUVER PANEL	1	
62	0207006000	HEX. NUT	18	
63	8215176004	DUCT	2	
	8215974504	LINING	1	
64	8215176204	DUCT	1	
	8215103404	LINING	1	
65	0017108020	HEX. HEAD BOLT	18	
66	0825007362	DOOR HANDLE	7	
	0605010225	KEY	1	
67	0021806016	MACHINE SCREW	28	
68	0845046904	HINGE	8	
	0845045004	WASHER	8	
69	0845047004	HINGE	8	
	0845045004	WASHER	8	
70	0019208020	HEX. HEAD BOLT	40	
71	0601850097	STOPPER	10	..... 30029
72	0021008025	MACHINE SCREW	10	
73	0845031504	CAP	20	
74	8215312002	SUPPORT LEG	1	
75	0017110030	HEX. HEAD BOLT	3	
76	0010110030	HEX. HEAD BOLT	2	
	0030010000	HEX. NUT	2	
	0040010000	LOCK WASHER	2	
	0041210000	PLAIN WASHER	2	
77	6360510003	EMBLEM	2	
78	0021106020	MACHINE SCREW	4	

ADD THE FOLLOWING DIGITS AFTER THE PART NUMBER  
WHEN ORDERING ANY PAINTED PANEL TO INDICATE  
COLOR OF UNIT:

1-ORANGE	5-BLACK
2-WHITE	6-CATERPILLAR YELLOW
3-SPECTRUM GRAY	7-CATO GOLD
4-SUNBELT GREEN	8-RED

THE SERIAL NUMBER MAY BE REQUIRED.

# DCA-400SPK — RUBBER SEAL ASSY.



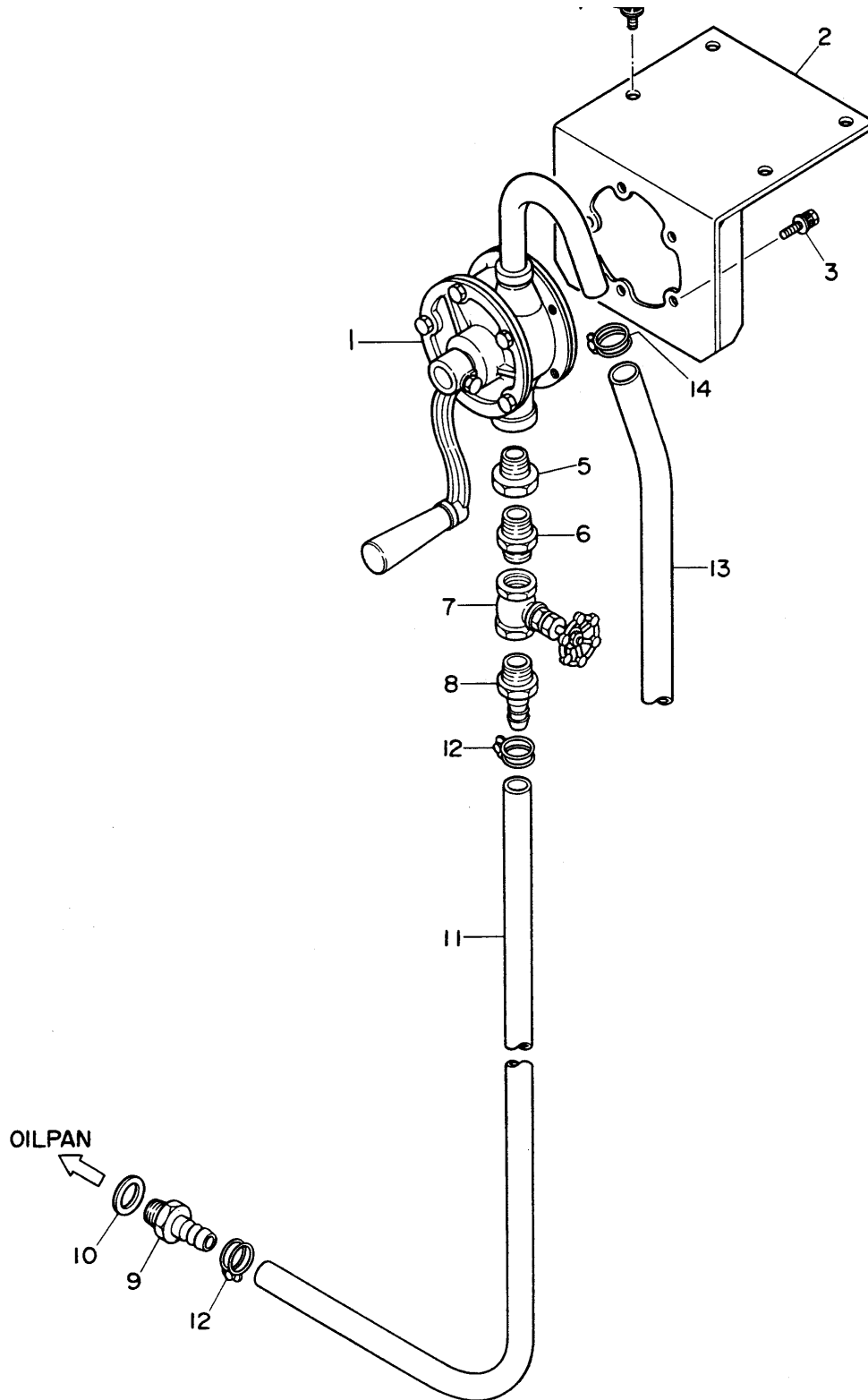
# DCA-400SPK — RUBBER SEAL ASSY.

## RUBBER SEAL ASSY.

<u>NO.</u>	<u>PART NO.</u>	<u>PART NAME</u>	<u>QTY.</u>	<u>REMARKS</u>
79	0228901450	RUBBER SEAL	3	
80	0228901390	RUBBER SEAL	3	
81	0228900795	RUBBER SEAL	8	
82	0228900850	RUBBER SEAL	1	
83	0229201440	RUBBER SEAL	1	
84	0229201440	RUBBER SEAL	2	
85	0228800795	RUBBER SEAL	2	
86	0228801240	RUBBER SEAL	2	
87	0229201340	RUBBER SEAL	1	
88	0228100120	RUBBER SEAL	4	
89	0228100510	RUBBER SEAL	4	

# DCA-400SPK — OIL PIPING ASSY.

OIL PIPING ASSY.



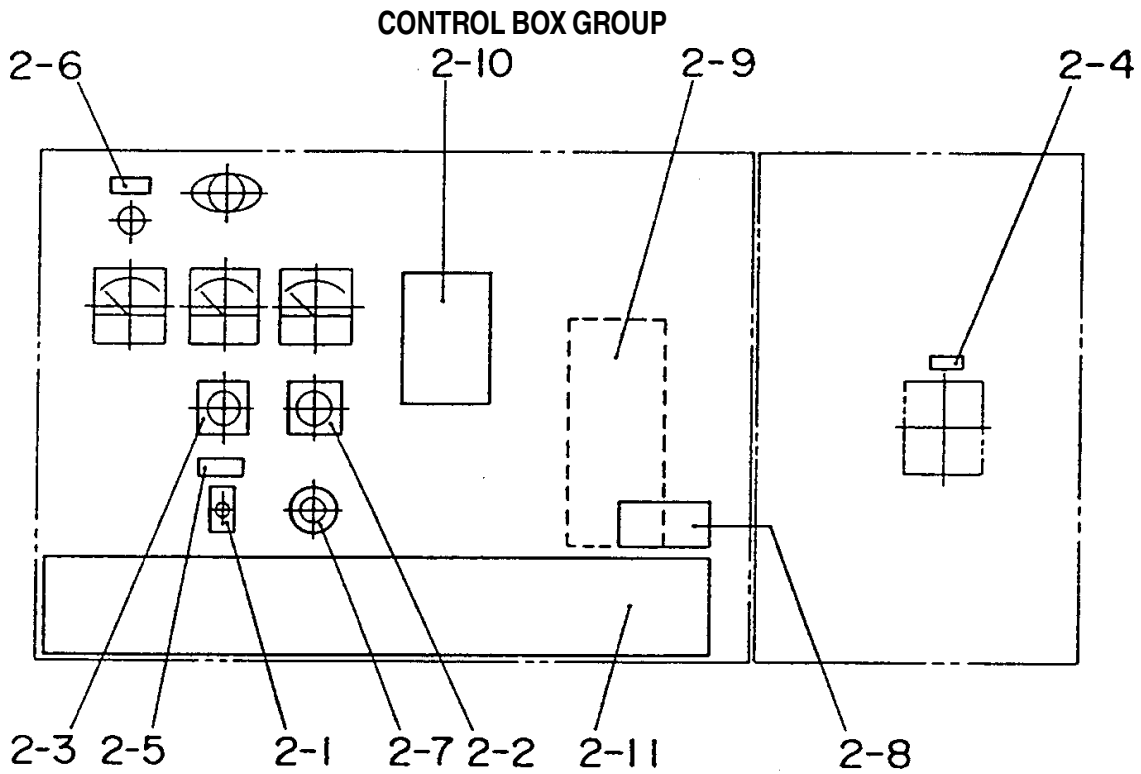
## DCA-400SPK — OIL PIPING ASSY.

### OIL PIPING ASSY.

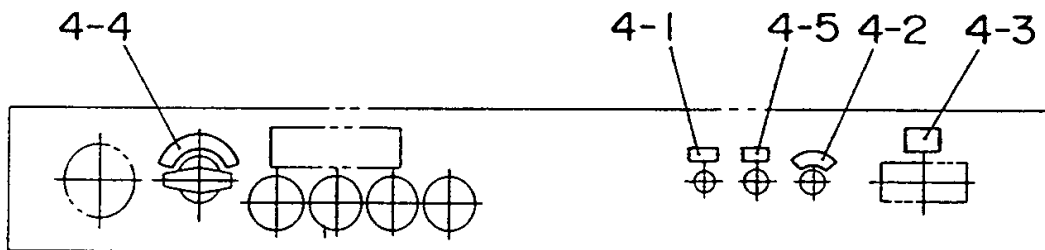
<u>NO.</u>	<u>PART NO.</u>	<u>PART NAME</u>	<u>QTY.</u>	<u>REMARKS</u>
1	0602023040	PUMP	1	
2	8215191013	BRACKET, PUMP	1	
3	0017106025	HEX. HEAD BOLT	5	
4	0017110030	HEX. HEAD BOLT	4	
5	7522054204	BUSHING	1	
6	0131506000	NIPPLE	1	
7	0120006005	VALVE	1	
8	3972027104	HOSE JOINT	1	
9	3972054104	HOSE JOINT	1	
10	3972054304	PACKING	1	
11	0265801650	HOSE	1	
12	0605515003	HOSE BAND	2	
13	0193301200	HOSE	1	
14	0605515004	HOSE BAND	1	

# DCA-400SPK — NAME PLATE AND DECALS

## NAME PLATE AND DECALS



## ENGINE OPERATING PANEL GROUP



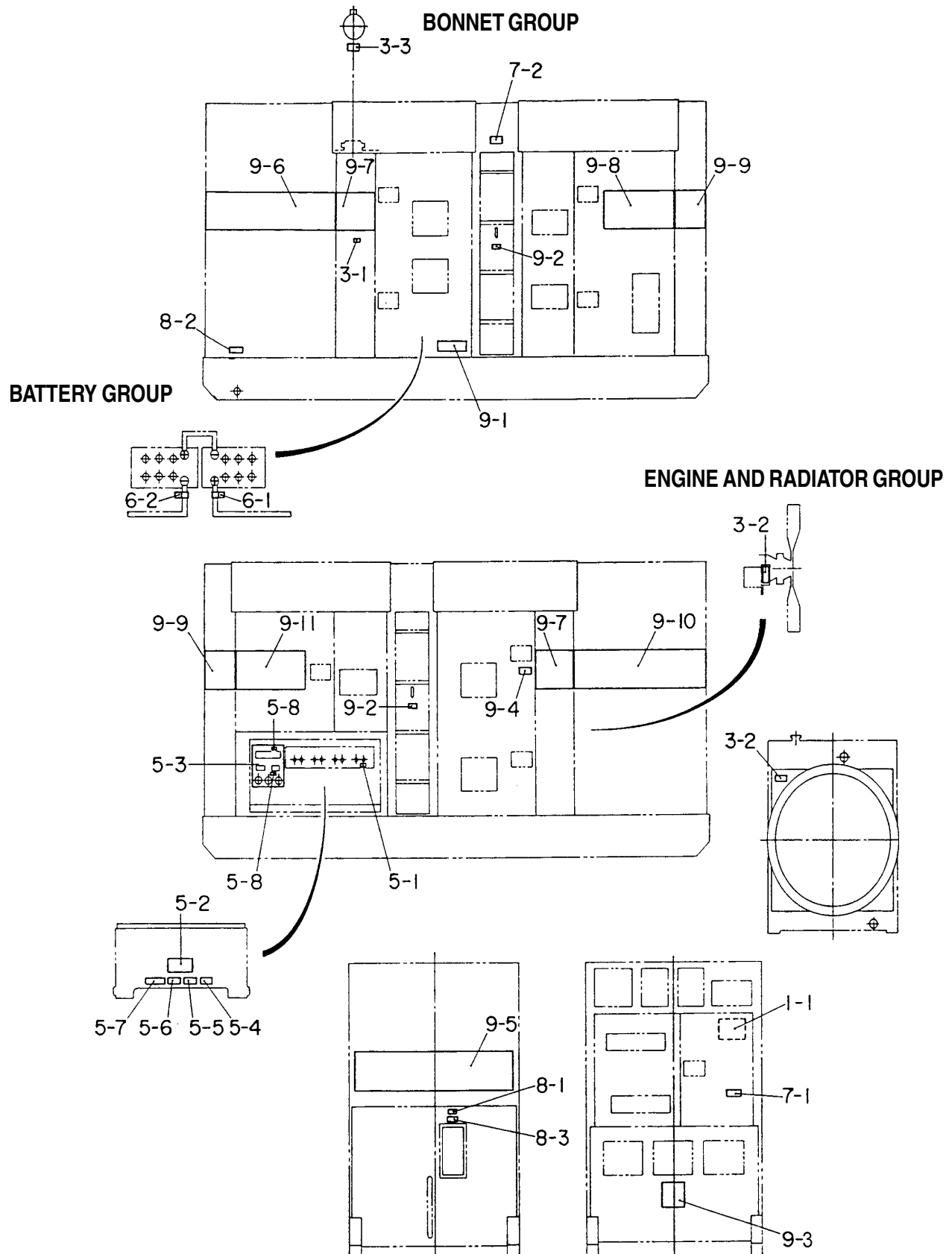
# DCA-400SPK — NAME PLATE AND DECALS

## NAME PLATE ASSY.

<u>NO.</u>	<u>PART NO.</u>	<u>PART NAME</u>	<u>QTY.</u>	<u>REMARKS</u>
<b>CONTROL BOX GROUP</b>				
2-1	0800520100	PLATE: ON-OFF .....	1 .....	AT-202
2-2	0800520904	PLATE: AMMETER CHNG.-OVER SWTH. ....	1 .....	N-2438
2-3	0800520814	PLATE: VOLTMETER CHNG.-OVER SWTH. ..	1 .....	N-2439
2-4	0840624504	DECAL: CIRCUIT BREAKER .....	1 .....	S-3031
2-5	0840624604	DECAL: PANEL LIGHT SWITCH .....	1 .....	S-3032
2-6	0840624704	DECAL: PILOT LAMP .....	1 .....	S-3033
2-7	0840624804	DECAL: VOLTAGE REGULATOR .....	1 .....	S-3034
2-8	B9531100604	DECAL: WARNING .....	1 .....	B93110060
2-9	C0551000903	DECAL: OUTPUT VOLTAGE SETTING .....	1 .....	C05100090
2-10	C2551000004	DECAL: SAFTETY INSTRUCTIONS .....	1 .....	C25100000
2-11	C3561101103	DECAL: WHISPERWATT 400 .....	1 .....	C36110110
<b>ENGINE OPERATING PANEL GROUP</b>				
4-1	0840625004	DECAL: PREHEAT LAMP .....	1 .....	S-3036
4-2	0840625104	DECAL: STARTER SWITCH .....	1 .....	S-3037
4-3	C0551000504	DECAL: BATTERY SWITCH .....	1 .....	C05100050
4-4	C0551000704	DECAL: LOW - HIGH .....	1 .....	C05100070
4-5	C0551000804	DECAL: STOP BUTTON .....	1 .....	C05100080

# DCA-400SPK — NAME PLATE AND DECALS

## NAME PLATE AND DECALS





# DCA-400SPK — NAME PLATE AND DECALS

NAME PLATE ASSY.

<u>NO.</u>	<u>PART NO.</u>	<u>PART NAME</u>	<u>QTY.</u>	<u>REMARKS</u>
<b>ENGINE &amp; RADIATOR GROUP</b>				
3-1	6360610304	DECAL: WATER .....	1	S-1880
3-2	B9504000404	DECAL: WARNING .....	2	B90400040
3-3	B9504100104	DECAL: WARNING .....	1	B90410010
<b>OUTPUT TERMINAL GROUP</b>				
5-1	0840614104	DECAL: GROUND .....	1	S-2635
5-2	0840619904	DECAL: DANGER .....	1	S2731
5-3	B4551000103	DECAL: RECEPTACLE & CIRCUIT BREAK ...	1	B45100010
5-4	B9511100304	DECAL: WARNING .....	1	B91110030
5-5	B9511100404	DECAL: WARNING .....	1	B91110040
5-6	B9531100504	DECAL: WARNING .....	1	B93110050
5-7	C0551000404	DECAL: 3-PHASE OUTPUT TERMINAL .....	1	C05100040
5-8	C1551000404	DECAL: 240/139 VOLT .....	2	C15100040
<b>BATTERY GROUP</b>				
6-1	0800689404	DECAL: + .....	1	S-2090
6-2	0800689504	DECAL: - .....	1	S-2091
<b>MUFFLER GROUP</b>				
7-1	B9504200004	DECAL: WARNING .....	1	B90420000
7-2	B9511100204	DECAL : CAUTION .....	1	B91110020
<b>FUEL TANK GROUP</b>				
8-1	1320620904	DECAL: DIESEL FUEL .....	1	S-1756
8-2	6360620004	DECAL: FUEL DRAIN PLUG .....	1	S-1883
8-3	B9504500004	DECAL: WARNING .....	1	B90450000
<b>BONNET GROUP</b>				
9-1	1320610603	DECAL: WATER - OIL .....	1	S-1760
9-2	1320621504	DECAL: SUPPORT HOOK .....	2	S-2257
9-3	0840625902	DECAL: MQ .....	1	S-3057
9-4	B9504000304	DECAL: CAUTION .....	1	B90400030
9-5	C3561101003	STRIPE	1	
9-6	C3561100903	STRIPE	1	
9-7	C3561100604	STRIPE	2	
9-8	C3561100803	STRIPE	1	
9-9	C3561100104	STRIPE	2	
9-10	C3561100703	STRIPE	1	
9-11	C3561100203	STRIPE	1	
1-1	0800655603	DECAL: HANDLING PROCEDURES .....	1	S-2763A

**PAYMENT TERMS**

Terms of payment for parts are net 10 days.

**FREIGHT POLICY**

All parts orders will be shipped collect or prepaid with the charges added to the invoice. All shipments are F.O.B. point of origin. Multiquip's responsibility ceases when a signed manifest has been obtained from the carrier, and any claim for shortage or damage must be settled between the consignee and the carrier.

**MINIMUM ORDER**

The minimum charge for orders from Multiquip is \$15.00 net. Customers will be asked for instructions regarding handling of orders not meeting this requirement.

**RETURNED GOODS POLICY**

Return shipments will be accepted and credit will be allowed, subject to the following provisions:

1. A Returned Material Authorization must be approved by Multiquip prior to shipment.
2. To obtain a Return Material Authorization, a list must be provided to Multiquip Parts Sales that defines item numbers, quantities, and descriptions of the items to be returned.
  - a. The parts numbers and descriptions must match the current parts price list.
  - b. The list must be typed or computer generated.
  - c. The list must state the reason(s) for the return.
  - d. The list must reference the sales order(s) or invoice(s) under which the items were originally purchased.
  - e. The list must include the name and phone number of the person requesting the RMA.
3. A copy of the Return Material Authorization must accompany the return shipment.
4. Freight is at the sender's expense. All parts must be returned freight prepaid to Multiquip's designated receiving point.
5. Parts must be in new and resalable condition, in the original Multiquip package (if any), and with Multiquip part numbers clearly marked.
6. The following items are not returnable:
  - a. Obsolete parts. (If an item is listed in the parts price book as being replaced by another item, it is obsolete.)
  - b. Any parts with a limited shelf life (such as gaskets, seals, "O" rings, and other rubber parts) that were purchased more than six months prior to the return date.
  - c. Any line item with an extended dealer net price of less than \$5.00.
  - d. Special order items.
  - e. Electrical components.
  - f. Paint, chemicals, and lubricants.
  - g. Decals and paper products.
  - h. Items purchased in kits.
7. The sender will be notified of any material received that is not acceptable.
8. Such material will be held for 5 working days from notification, pending instructions. If a reply is not received within 5 days, the material will be returned to the sender at his expense.
9. Credit on returned parts will be issued at dealer net price at time of the original purchase, less a 15% restocking charge.
10. In cases where an item is accepted for which the original purchase document can not be determined, the price will be based on the list price that was effective twelve months prior to the RMA date.
11. Credit issued will be applied to future purchases only.

**PRICING AND REBATES**

Prices are subject to change without prior notice. Price changes are effective on a specific date and all orders received on or after that date will be billed at the revised price. Rebates for price declines and added charges for price increases will not be made for stock on hand at the time of any price change.

Multiquip reserves the right to quote and sell direct to Government agencies, and to Original Equipment Manufacturer accounts who use our products as integral parts of their own products.

**SPECIAL EXPEDITING SERVICE**

A \$20.00 to \$50.00 surcharge will be added to the invoice for special handling including bus shipments, insured parcel post or in cases where Multiquip must personally deliver the parts to the carrier.

**LIMITATIONS OF SELLER'S LIABILITY**

Multiquip shall not be liable here under for damages in excess of the purchase price of the item with respect to which damages are claimed, and in no event shall Multiquip be liable for loss of profit or good will or for any other special, consequential or incidental damages.

**LIMITATION OF WARRANTIES**

No warranties, express or implied, are made in connection with the sale of parts or trade accessories nor as to any engine not manufactured by Multiquip. Such warranties made in connection with the sale of new, complete units are made exclusively by a statement of warranty packaged with such units, and Multiquip neither assumes nor authorizes any person to assume for it any other obligation or liability whatever in connection with the sale of its products. A part from such written statement of warranty, there are no warranties, express, implied or statutory, which extend beyond the description of the products on the face hereof.



# PARTS AND OPERATION MANUAL

## **HERE'S HOW TO GET HELP**

*PLEASE HAVE THE MODEL AND SERIAL NUMBER  
ON-HAND WHEN CALLING*

### **PARTS DEPARTMENT**

*800/427-1244 or 310/537-3700*

*FAX: 800/672-7877 or 310/637-3284*

### **SERVICE DEPARTMENT**

*800/835-2551 or 310/537-3700*

*FAX: 310/638-8046*

### **WARRANTY DEPARTMENT**

*800/835-2551 or 310/537-3700*

*FAX: 310/638-8046*

### **MAIN**

*800/421-1244 or 310/537-3700*

*FAX: 310/537-3927*

Manufactured for Multiquip Inc.  
by  
DENYO MANUFACTURING, CO., USA



#### **MULTIQUIP INC.**

POST OFFICE BOX 6254  
CARSON, CA 90749  
310-537-3700 • 800-421-1244  
FAX: 310-537-3927  
E-MAIL: [mq@multiquip.com](mailto:mq@multiquip.com)  
WWW: [multiquip.com](http://multiquip.com)

Atlanta • Boise • Dallas • Houston • Newark  
Quebec, Canada • Manchester, UK • Rio De Janeiro, BR • Guadalajara, MX