



PERFECT HEAT.



CARE & USE MANUAL

**PROFESSIONAL
48", 36" & 30"
DUAL FUEL RANGE MODELS**



Retain this manual for future reference.

Shown here is your warranty serial number. Have it available in the event your product needs service

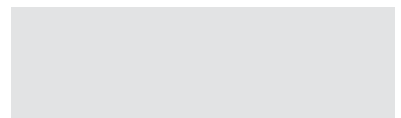

TABLE OF CONTENTS

Propane Gas Installation.....	1
General Safety Instructions.....	2
<i>Precautions</i>	2-4
Model / Parts Identification.....	5-6
Before Using Your Appliance.....	7
<i>Cooktop Use</i>	8-10
<i>Grill Use</i>	11-12
<i>Griddle Use</i>	13-14
Oven Use.....	15-23
<i>Oven Baking</i>	15-18
<i>Oven Broiling</i>	18-19
<i>12" Oven Proofing</i>	21
<i>27" & 24" Oven Self Cleaning</i>	21-23
Care and Maintenance.....	24-28
<i>Cooktop Care</i>	24-25
<i>Griddle Care</i>	25-26
<i>Grill / Control Knob Care</i>	26
<i>Oven / Oven Door Installation</i>	27
<i>Oven Racks / Rack Slides</i>	27
<i>Oven Light Bulb Replacement</i>	28
In Case of Power Failure.....	28
Leveling the Grates.....	28
Warranty Information.....	29

PROPANE GAS INSTALLATION

All of the appliances mentioned in this manual were manufactured for use with natural gas. They may be converted for use with propane gas. This must be done by a qualified installer or service technician. Be sure the appliance is correct for the type of gas being used.

- ❗ **CAUTION:** When connecting the appliance to **propane gas**, make sure the propane gas tank is equipped with its own high pressure regulator in addition to the pressure regulator supplied with the appliance. The maximum gas pressure to this appliance is not to exceed 14.0 inches water column from the gas tank pressure regulator.

❗ **WARNING:** If the information in this manual is not followed exactly, a fire or explosion may result causing property damage, personal injury or death.

- Do not store or use gasoline or other flammable vapors and liquids in the vicinity of this or any other appliance.
- WHAT TO DO IF YOU SMELL GAS
 - Do not try to light any appliance.
 - Do not touch any electrical switch; do not use any phone in your building.
 - Immediately call your gas supplier from a neighbor's phone. Follow the gas supplier's instructions.
 - If you cannot reach your gas supplier, call the fire department.
- Installation and service must be performed by a qualified installer, service agency or the gas supplier.

- TO ENSURE WARRANTY SERVICE, FILL OUT AND SEND THE WARRANTY CARD.

SAFETY PRACTICES TO AVOID PERSONAL INJURY

-READ AND UNDERSTAND THESE PRECAUTIONS BEFORE USING THIS APPLIANCE.

Thank you for choosing your new DCS Professional Range. Our products are designed to be safe and reliable when properly cared for and used reasonably. When using this restaurant caliber appliance, use it with extreme care, as this type appliance provides intense heat and can increase the accident potential. Basic safety precautions must be followed when using kitchen appliances, including the following:

Read this Care and Use Manual thoroughly before using your new appliance. This will help to reduce the risk of fire, electric shock, or injury to persons.

Begin by insuring proper installation and servicing. Follow the installation instructions which came with this appliance. Be sure to have a qualified technician install and ground this appliance before using.

Have the installer show you where the gas supply shutoff valve is located so you will know how and where to turn off the gas to the appliance.

If you smell gas, the installer has not done a proper job of checking for leaks. You can have a small leak and therefore a faint gas smell if the connections are not completely tight. Finding a gas leak is not a “do-it-yourself” procedure. Some leaks can only be found with the burner control in the ON position and for your protection it must be done by a qualified service technician.

If by some chance a burner goes out and gas escapes, open a window or a door to let the room air out. Do not attempt to use the appliance until the gas has had time to dissipate. Follow the instructions on page 1, “What to do if You Smell Gas”.

This appliance has been factory assembled for natural gas. It should be correctly adjusted by a qualified service technician or installer for the type of gas that is used.

Do not repair or replace any part of this appliance unless it is specifically recommended in this manual. All other servicing should be referred to a qualified technician.

Never “open door broil” with children nearby. They could quickly come into contact with a hot oven inner surface, causing severe burns.

Children should not be left alone or unattended in an area where appliances are in use. They should never be allowed to turn knobs, push buttons, sit or stand on any part of an appliance.

Children in walkers, or children crawling can be attracted to the round oven door handle and may grab and open the oven door. This can result in injury from the door being pulled open on a child, or severe burns if the oven is in use and hot.

CAUTION: Do not store items of interest to children above or at the back of any appliance. Children could be seriously injured if they should climb onto the appliance to reach these items.

Never store anything in the oven or on the cooktop. Flammable materials can catch fire, plastic items may melt or ignite and other types of items could be ruined.

Do not hang articles from any part of the appliance or place anything against the oven. Some fabrics are quite flammable and may catch on fire.

If the appliance is near a window **be certain the curtains do not blow** over or near the cooktop burners; they could catch on fire.

Do not use water on grease fires. Turn all burners OFF, then smother fire with baking soda or use a dry chemical or foam-type fire extinguisher.

SAFETY PRACTICES TO AVOID PERSONAL INJURY

Never let clothing, pot holders, or other flammable materials come in contact with, or too close to, any burner or burner grate until it has cooled. **Fabric may ignite** and result in personal injury.

Be certain to use **only dry pot holders**: moist or damp pot holders on hot surfaces may cause burns from steam. Do not use a towel or other bulky cloth in place of pot holders. Do not let pot holders touch hot burners, or burner grates.

For personal safety, **wear proper apparel**. Loose fitting garments or hanging sleeves should never be worn while using this appliance. Some synthetic fabrics are highly flammable and should not be worn while cooking.

Do not use aluminum foil to line any part of the oven or cooktop. Using a foil liner could result in a fire hazard, or the obstruction of the flow of combustion and ventilation air. Foil is an excellent heat insulator and heat will be trapped underneath it. This trapped heat can upset the cooking performance and can damage the finish of the oven or the cooktop parts.

Warning: This appliance is for cooking. Based on safety considerations, never use the oven or cooktop to warm or heat a room. Also, such use can damage the cooktop or oven parts.

When using the cooktop: **DO NOT TOUCH THE BURNER GRATES or THE IMMEDIATE SURROUNDING AREA**. Areas adjacent to the burners may become hot enough to cause burns.

When using the oven: **DO NOT TOUCH THE INTERIOR SURFACES OF THE OVEN, THE EXTERIOR AREA IMMEDIATELY SURROUNDING THE DOOR or THE BACK TRIM**. The drip tray handles directly above the oven door may be hot if the oven has been operated with the door open, or if something has prevented the door from sealing.

Always use caution when pulling out the drip trays when the oven has been on, or is currently on. The drip trays get hot when the oven is on. Do not remove drip trays until they are cool.

Never leave the cooktop unattended when using high flame settings. Boil overs cause smoking and greasy spill overs that may ignite. More importantly, if the burner flames are smothered by a severe boil over which effects the igniter, unburned gas will escape into the room. See page 1.

Only certain types of glass, heat-proof glass-ceramic, ceramic, earthen ware, or other glazes utensils are suitable for cooktop use. This type of utensil may break with sudden temperature changes. Use only on low or medium flames settings according to the manufacturer's directions.

Do not heat unopened food containers; a build up of pressure may cause the container to burst.

During cooking, **set the burner control so that the flame heats only the bottom of the pan** and does not extend beyond the bottom of the pan. This could heat and/or melt the handles.

Always use utensils that have flat bottoms large enough to cover the burner. The use of undersized utensils will expose a portion of the flame to direct contact and may result in ignition of clothing.

To minimize burns, ignition of flammable materials and unintentional spill overs, position handles of **utensils inward** so they do not extend over adjacent work areas, cooking areas, or the edge of the cooktop.

Hold the handle of the pan to prevent movement of the utensil when stirring or turning food.

SAFETY PRACTICES TO AVOID PERSONAL INJURY

Do not use the grill for cooking excessively fatty meats or products which promote flare-ups. DO NOT use cooking utensils on the grill.

GREASE IS FLAMMABLE. Let hot grease cool before attempting to handle it. Avoid letting grease deposits collect in the container under the cooktop burners, the grill or the griddle. Clean after each use or boil over.

For proper lighting and performance of the cooktop burners, **keep the burner ports clean.** It may be necessary to clean these when there is a boil over or when the burner does not light, even though the electronic igniters click.

Clean the cooktop with caution. Avoid steam burns; do not use a wet sponge or cloth to clean the cooktop while it is hot. Some cleaners produce noxious fumes if applied to a hot surface. Follow directions provided by the cleaner manufacturer.

Be sure all the range and/or cooktop controls are turned off and the appliance is cool before using any type of aerosol cleaner on or around the appliance. The chemical that produces the spraying action could, in the presence of heat, ignite or cause metal parts to corrode.

Place oven racks in desired position while the oven is cool. If a rack must be moved while the oven is hot, do not let the pot holders contact the hot interior of the oven.

Use care when opening the oven door; let hot air or steam escape before removing or replacing foods.

Do not rub, damage, move or remove the door gasket. It is essential for a good seal during baking.

Clean the ventilator hood and filters above the range or cooktop frequently so grease from cooking vapors does not accumulate on them.

Turn the ventilator OFF in case of fire or when intentionally “flaming” liquor or other spirits on the cooktop. The blower, if in operation, could unsafely spread the flames.

DO NOT obstruct the flow of combustion or ventilation air to the appliance. Be sure a fresh air supply is available.

For safety reasons and to avoid damage to the appliance never sit, stand, or lean on the oven door or cooking surface.

Service should only be done by authorized technicians. Technicians must disconnect the power supply before servicing this appliance.

California Proposition 65 - Warning: The burning of gas cooking fuel generates some by-products which are known by the State of California to cause cancer or reproductive harm. California law requires businesses to warn customers of potential exposure to such substances. To minimize exposure to these substances, always operate this unit according to the instructions contained in this booklet and provide good ventilation to the room when cooking with gas.

SAVE THESE INSTRUCTIONS

PARTS IDENTIFICATION

EXTERIOR PARTS IDENTIFICATION- (RD 484GG SHOWN)

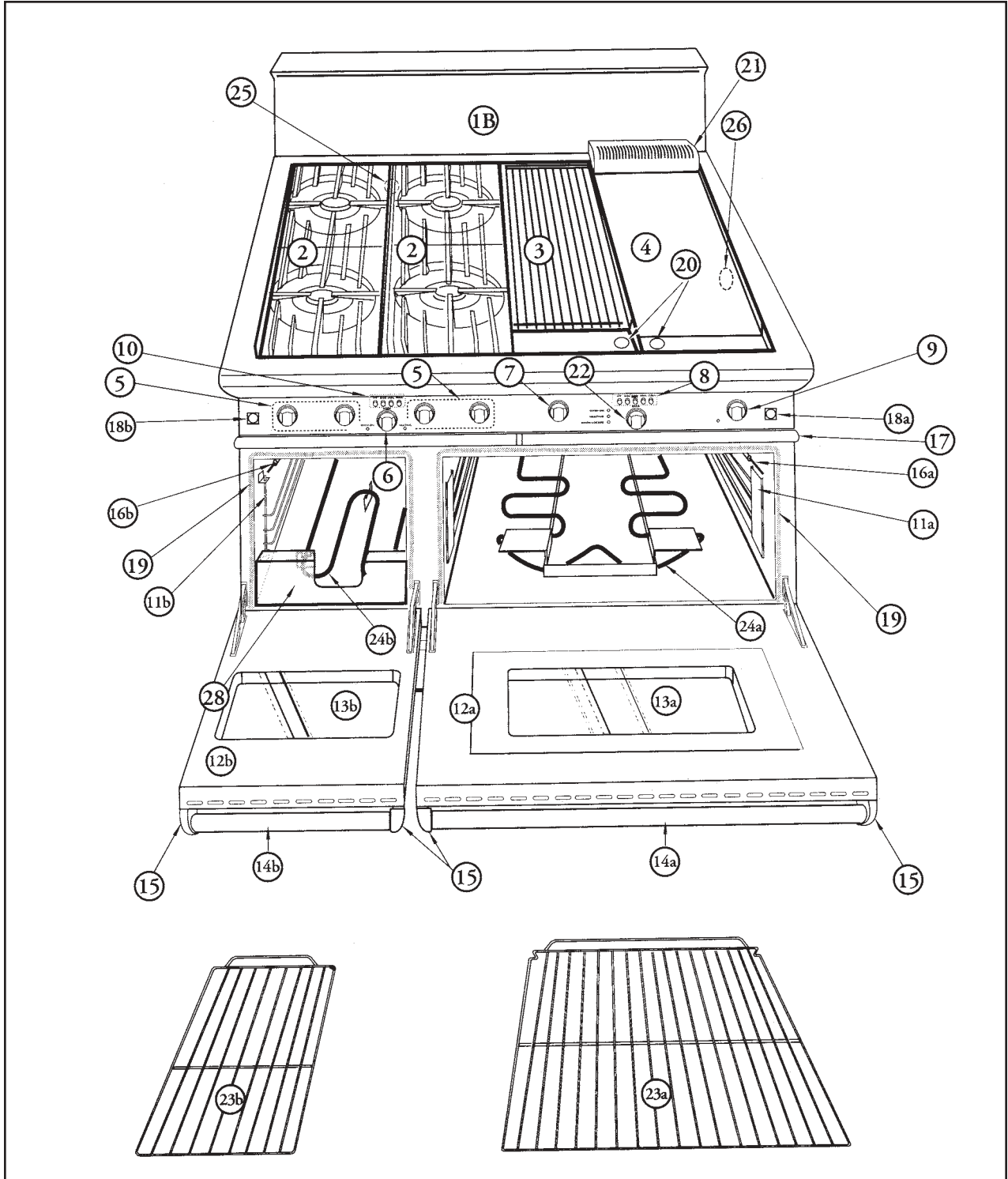

SEE PAGE 6 FOR PART LIST ↓

MODEL / PARTS IDENTIFICATION

DUAL-FUEL RANGE MODELS

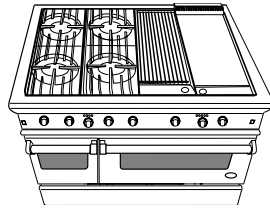

DCS-RD-484GG

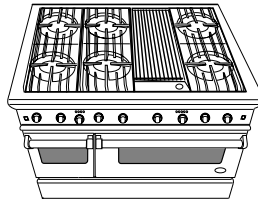

DCS-RD-486GL

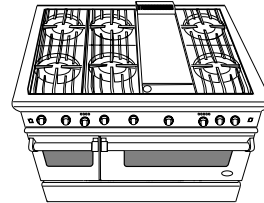

DCS-RD-486GD

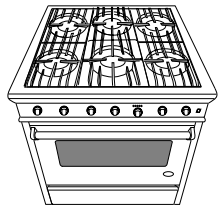

DCS-RD-366

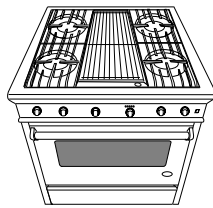

DCS-RD-364GL

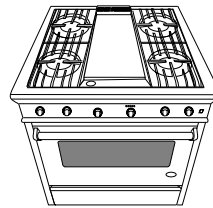

DCS-RD-364GD

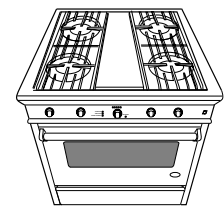

DCS-RD-304

PARTS IDENTIFICATION

1. *Backguard.* a-Island Trim, b-LowBack, c- Hi-Shelf
2. Burner Grates / Burners
3. Grill
4. Griddle
5. Cooktop Burner Control Knobs
6. Proofing Oven Control Knob
7. Grill Control Knob
8. Large Oven Mode Control Buttons
9. Griddle Control Knob
10. Small Oven Control Knobs
11. Oven Rack Slides. a-27", 24" Oven, b-12" Proofing Oven
12. *Oven Door.* a-27", 24" Oven, b-12" Proofing Oven
13. *Oven Window.* a-27", 24" Oven, b-12" Proofing Oven
14. *Door Handle.* a-27", 24" Oven, b-12" Proofing Oven
15. Door Handle Endcap
16. *Thermostat Bulb.* a-27" Oven, and 24" Oven there are two bulbs top one is Main Thermostat lower one is Auto reset
17. Drip Pans
18. *Oven Light Switch.* a-27" Oven, b-12" Proofing Oven
19. Oven Door Gasket
20. Drain Tubes
21. Griddle Flue Cover (Vent)
22. 27" Oven Control Knob
23. *Oven Racks.* a-27" Oven Bake/Broil (3), b-12" Proofing Oven (2)
24. *Oven Heating Element.* a-27" Oven Bake, b-12" Proofing Oven Bake, c-27" Oven Broil, d-12" Proofing Oven Broil, e 30" Oven Bake/Broil
25. Rating Plate / Serial Number.-(in rear of Burner Box below Grates-- can be seen when Grates are removed)
26. Oven Light
27. Convection Fan Baffle
28. 12" Oven Crumb Catch Tray

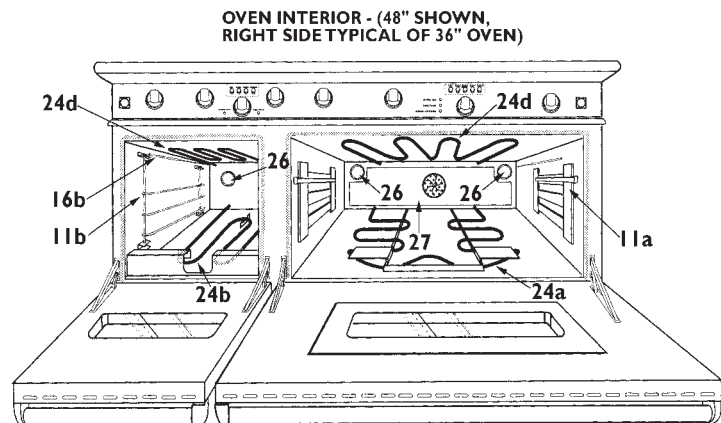
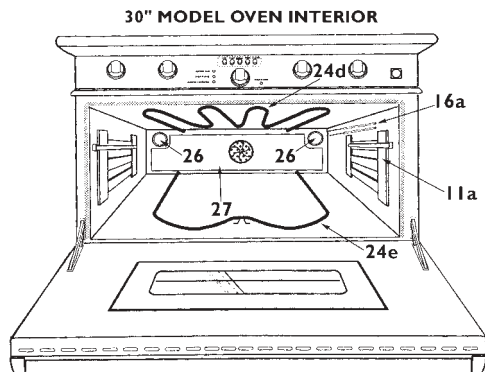

BEFORE USING YOUR APPLIANCE

1. Remove all packaging materials and labels from your appliance. If the installer has not set up your appliance, do it now. Check that you have the following items:

COOKTOP - (depending on model)

- Four or six burners, burner bowls, burner caps and grates
- Griddle
- Grill racks, 2 pieces
- Radiant tray, 6 removable rods - to hold briquettes and briquettes for grill
- One or two removable drip trays (griddle and grill models have drip tray liners, for catching the grease)
- Back splash or back trim

OVEN - (depending on model)

27" & 24" OVEN:

- Three Oven Racks
- Two removable Stainless Steel 3 position Rack Slide Assemblies
- One, Two-piece broil pan

12" OVEN:

- Two oven racks
- Two removable Rack Supports
- One, Two-piece broil pan

2. Place the oven racks in the proper position **before turning on the oven.**

For correct rack position check your recipe. The most frequently used position is number 2. The rack positions are numbered from the bottom as in the floors of a building.

To insert the oven racks:

- A. Hold the rack with the back safety rail in the up position and towards the rear of the oven. Slip it into the oven so the rack slides are between the rack and the rack guides.
- B. As you slide the rack into the oven tip the front of the rack up slightly, so that the safety stops on the back of the rack, clear the rack slides. The safety stops keep the rack from sliding out of the oven when pulled forward.

To remove or reposition the racks:

- A. Pull the rack forward.
- B. Lift the front of the rack up so the safety stops clear the rack slides.
- C. Pull the rack forward.

⚠ Do not use aluminum foil to cover the oven racks or to line the oven. Heat can be trapped beneath the foil, this can cause damage to the oven and the food may not cook correctly.

3. Before baking or broiling:

One at a time turn on the oven and broiler elements for 20 to 30 minutes each. This burns off the manufacturing oils used by the factory. Turn the oven element on to 450°F and the broiler element on to "Broil". Turn on the ventilator above your range while these burners are on, as there will be an odor.

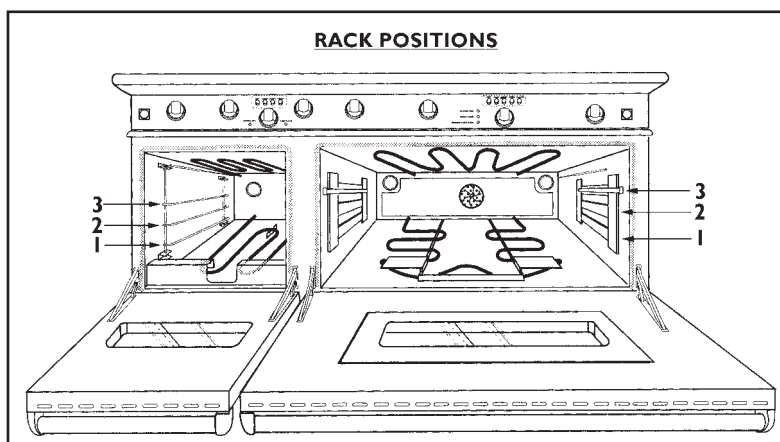

COOKTOP USE

BURNERS

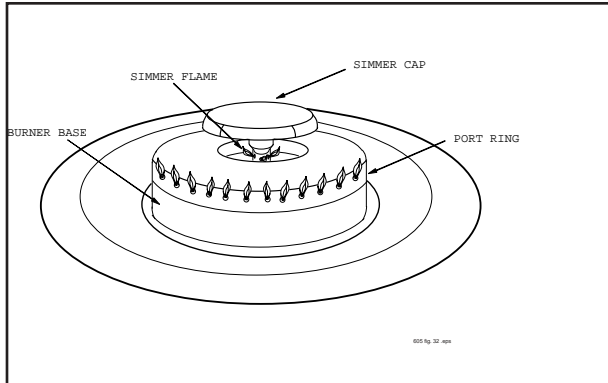

Your new professional gas range or cooktop is equipped with burners typical of those used in restaurants. These burners are designed in two pieces for maximum cleanability and controllability. The center, smaller cap covers and protects the simmer burner from boil overs, that could put the flame out. This cap also spreads the simmer burner heat out to avoid too much heat being concentrated on the center of the pan. The simmer burner is always on when the burner is in use. The burner should never be operated if the simmer cap is not in place.

All the cooktop burners have electronic spark ignition to eliminate continuously burning pilots, when the port ring is on and the flame is blown out, it will relight. This two piece burner has a (BTU) range at the highest of 15,000 with a variable simmer that has a range between 1250-500 (BTU'S).

After cleaning, it is important to make sure the locating pin on the top side of the burner base is properly aligned with the corresponding slot in the burner base. Incorrect alignment will produce a potentially dangerous flame and poor burner performance.

When standing in front of the range, the locating pin on the burner base and corresponding slot in the port ring is located at approximately the 3 o'clock position. *See the following illustration at top of next column.*

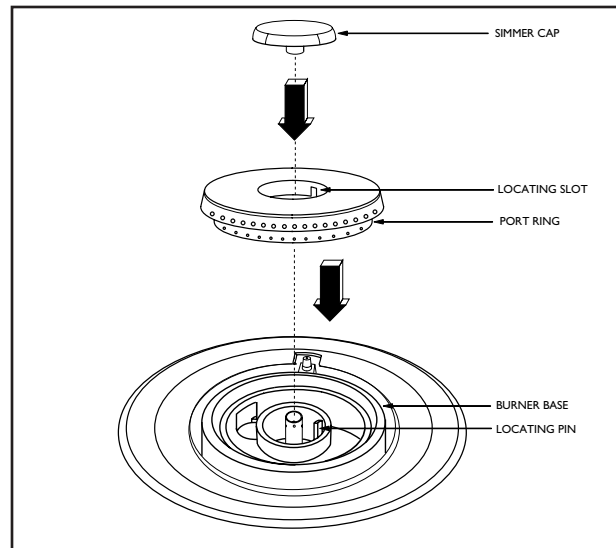

SIMMERING

Your new professional cooktop has exceptionally low simmering capabilities. The center simmer cap serves as a heat diffuser to spread out the heat to avoid having a center hotspot. Keep in mind that because of the high heat capacity of the outer burner, and the mass of the cast iron burner grates (they retain heat longer than lighter, conventional grates) some foods may continue to cook by retained heat after the burner has been turned off.

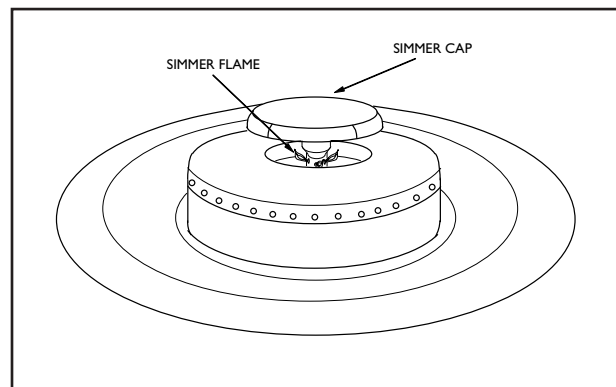

The simmer burner is lit from the outside burner flame. The flame travels over the port ring and crosses over onto the simmer burner located just beneath the simmer cap. When lighting only the simmer burner always light the main burner first. This will in turn provide the ignition source for the simmer burner. Look to ensure that the simmer ports are lit before turning the knob down to the simmer position. Should a strong draft or boil over extinguish the simmer

COOKTOP USE

flame it will not relight automatically as the outer burner would.

ELECTRONIC IGNITERS

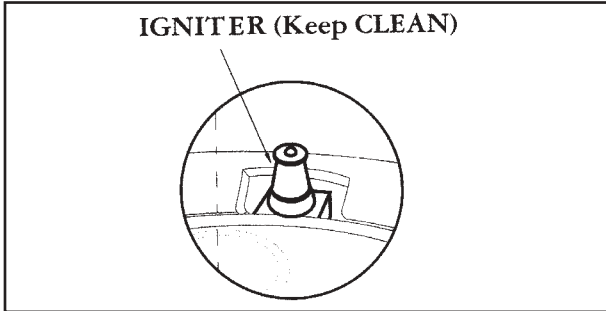

If a burner does not ignite, listen for the clicking sound. If the igniter is not clicking, **TURN OFF THE BURNER**. Check the circuit breaker for a blown fuse or a tripped circuit breaker. If the igniter still fails to operate, see page 28, "Before Calling For Service". To light the burner manually, see page 28, "Power Failure".

NOTE: If you are using propane gas, a slight pop or flash may occur at the burner ports a few seconds after the burner has been turned "off". This "extinction pop" is normal for propane gas.

BURNER EFFICIENCY and FLAME CHARACTERISTICS

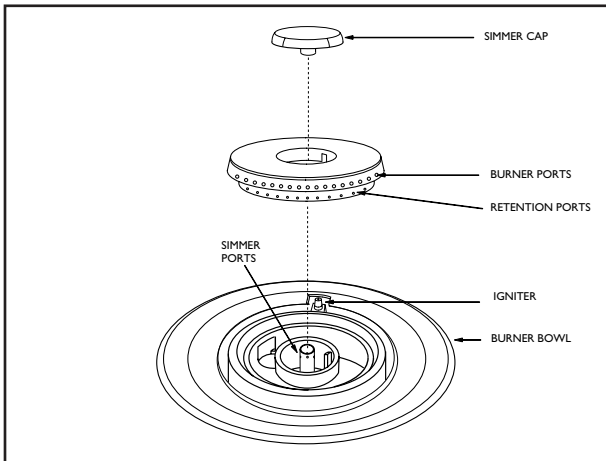

It is necessary to keep the burner ports and the igniters clean, for proper lighting and efficient performance of the cooktop burners.

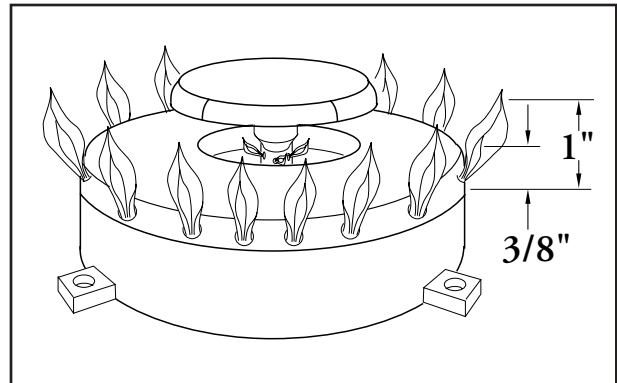

The burner flame should burn completely around and within the burner with no excessive noise or lifting. The flame should be blue in color and stable with no yellow tips.

An improper air-gas mixture may cause either a burner flutter or a yellow tipped flame. A technician should adjust the flame. During initial use, foreign particles in the gas line, or dust in or in the air around the appliance may cause an orange flame. This will disappear with use.

FLAME HEIGHT

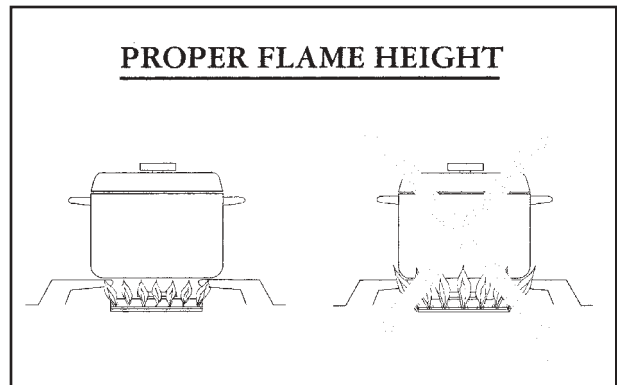

The correct height of the flame mainly depends on the size of the bottom of the cooking utensil, the material of the cooking utensil, the amount and type of food and the amount of liquid in the utensil. Following are some basic rules for selecting flame height.

COOKTOP USE

- For safety reasons the flame must never extend beyond the bottom of the cooking utensil. Never allow flames to curl up the side of the pan.
- Utensils which conduct heat slowly (such as glass-ceramic) should be used with medium to low flames. If you are cooking with a large amount of liquid a slightly larger flame can be used.

BURNER GRATES

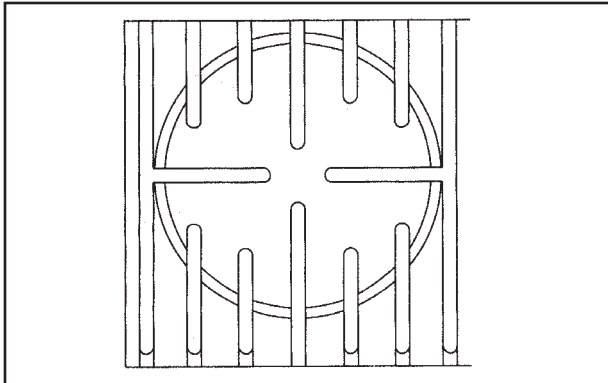

The burner grates are heavy cast iron coated on both sides with porcelain enamel. They were designed in sections to make them easier to remove and clean. Because they are coated on both sides, they can be placed in the dishwasher to clean. For additional cleaning tips see the porcelain enamel cleaning section on page 24. The grates also come equipped with leveling screws. See page 28.

DRIP TRAY and DRIP TRAY LINER

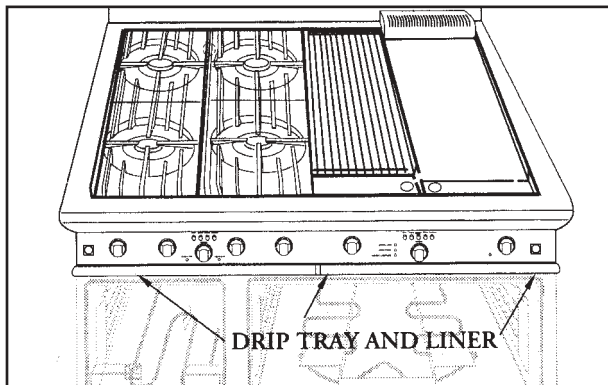

Located under the burners and/or the griddle and/or the grill is a stainless steel drip tray/s. On models with the griddle and/or grill there is also a drip tray liner. Pull the tray/s out for cleaning **after they are cool**.

- ❗ **DO NOT PULL THE DRIP TRAY OR THE LINERS OUT DURING OR IMMEDIATELY AFTER COOKING ON THE OVEN, THE GRILL OR THE GRIDDLE.**

HOT GREASE MAY BE RUNNING FROM THE GRILL OR THE GRIDDLE INTO THE DRIP TRAY LINERS.

COOKING UTENSILS

For best results we recommend using Professional Cookware. This type of utensil can be found at your finer department stores, specialty cooking shops, or Restaurant Supply Stores. If using regular cookware be very careful if the pans have plastic handles, as these large professional size burners can flame up on the outside of the pan and melt or bubble the handles.

CONTROL KNOBS

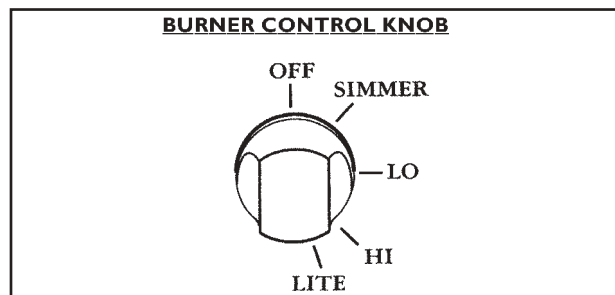

The control knobs are readily associated with the burners they control. The cooktop control knobs are in front of the burners, the grill and/or the griddle they control. The oven or griddle control/s are placed slightly lower than the control knobs. This is due to the physical size of the commercial type thermostats used on the product.

The cooktop burners have an infinite number of heat settings as there are no fixed positions between HI and LO. To turn ON a cooktop burner, push the control in, then turn it counterclockwise to the LITE position. You will hear the igniter click. When the gas is ignited all around the burner, turn the knob back to the desired setting. When using the simmer burner always ensure that the simmer burner lights from the main burner.

GRILL USE

GRILL

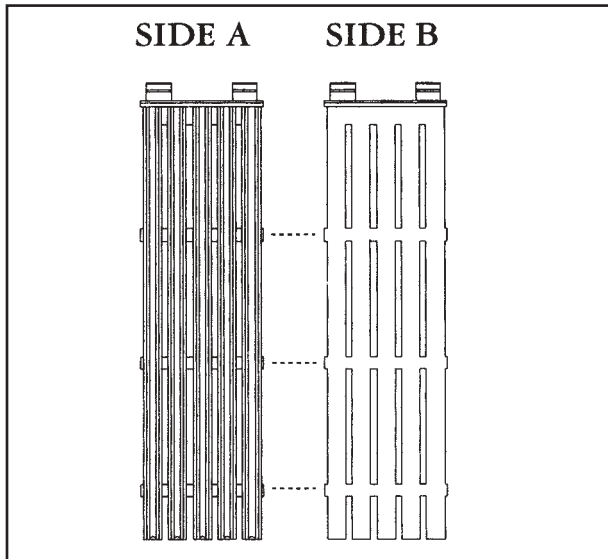

The two-piece grill rack is reversible. Place the side with the two grooved tabs towards the back of the cooktop. The grill rack is made of cast iron and has a black porcelain finish. One side of the grill is ridged and should be used for foods where you want the fat to run off, such as steak or hamburger patties. The ridges are sloped so the fat runs toward the front of the grill and can easily run down to the cooler area of the drip tray and away from the intense heat of the burner. The other side of the grill was designed for foods that need more support while cooking, such as fish.

Food cooked on this grill achieves the same flavor as food cooked on an outdoor grill. The intense radiant heat from the ceramic briquettes caramelizes the fats and juices that are brought to the surface of the food, giving it the barbecued flavor. This gas grill may cook slightly faster than you are used to.

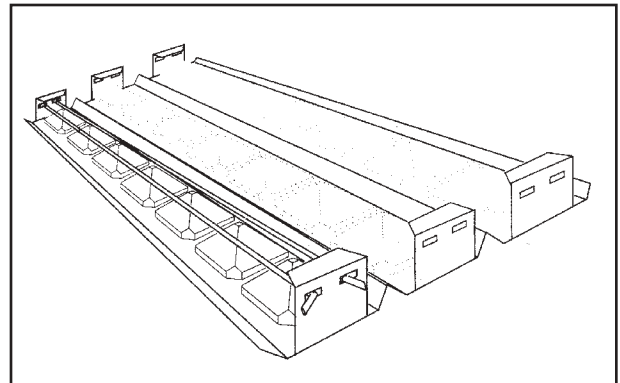

CERAMIC BRIQUETTES

The layer of ceramic briquettes, under the grill racks, will last for many years with proper care. They are shipped from the factory pre-assembled on the radiant tray, ready to be set in place into the fire box, under the grill racks. Be sure to remove any packaging material from the radiant tray and briquettes before using the grill. Burned food particles and ash can be emptied off the radiant tray when cool by shaking over a waste receptacle. Chipping or cracking of the briquettes may occur as they may get brittle with age, depending on frequency of use. This is normal and does not affect the cooking. Do not replace the radiant tray/briquettes with alternates. Contact DCS for genuine factory-direct replacement parts.

USE OF THE GRILL

For proper searing and browning the grill requires high heat. When cooking you will usually use the HI heat the entire cooking time. With large pieces of meat or poultry you may need to turn the heat to a lower setting after the food has been seared. This lower heat setting will allow the food to cook through without burning the outside. When using a sugary marinade or barbecue sauce it may be necessary to turn the heat setting down, near the end of the cooking time. Do not leave the grill unattended while it is turned on.

Before starting to cook on the grill, be sure the drip tray and liners are in place and that you have the grill racks turned to the side you want for cooking. Preheat the grill for 15 minutes with the control knob set on HI. When the grill is preheated, place the food on the grill. Cook it to the doneness desired. During cooking it may be necessary to adjust the heat setting. The control knob may be set to any position between HI and LO. When you are finished cooking allow the grill and the drip trays to cool before cleaning them.

GRILL USE

They should be cleaned each time they are used.

NOTE: The longer you preheat the grill, the darker the grill marks.

EXCESSIVE FLARE UPS and FLAMING

Occasionally grease drippings ignite. These drippings will create minor puffs of flame for a second or two. This is normal when cooking on a barbecue. You may find it handy to have a spray bottle filled with water to lightly spray the flare-up.

If the flame becomes excessive, remove the food from the grill. Lower the heat setting. Replace the food when the flare-up subsides. To prevent flare-ups from happening, trim the fat from around the edges of steaks and chops, use hamburger that is lean, remove the fat that is on poultry, etc.

When turning any kind of meat or poultry, the melted fat will drop onto the briquettes and it may create a flare-up. If this happens, use a long handled spatula to move the food to another area.

⚠ DO NOT leave the grill unattended while it is turned on.

GRILLING HINTS

The doneness of meat is affected by the thickness of the cut. It is impossible to cook a thin piece of meat to a rare doneness. A steak should be at least 1-inch thick to have it turn out rare and juicy. The cooking time is affected by the temperature of the meat when you start to cook it, the size and shape of the cut and the kind of meat you are cooking. The degree of doneness desired also affects the time.

When turning the meat over always use a spatula as it will not puncture the meat allowing the juices to run out. This will help to keep the meat juicy. Turn the meat only once, as juices are lost when the meat is repeatedly turned. Season or salt the meat after it has been cooked, these products have a tendency to dry the meat out.

Be sure to trim any excess fat from meat or poultry. To prevent steaks or chops from curling while they are being cooked, slit the fat around the edges at about 2-inch intervals. To test for doneness, make a small cut in the center of the meat.

USE THIS SPACE TO SAVE GRILLING NOTES AND YOUR FAVORITE RECIPES:

GRIDDLE USE

GRIDDLE

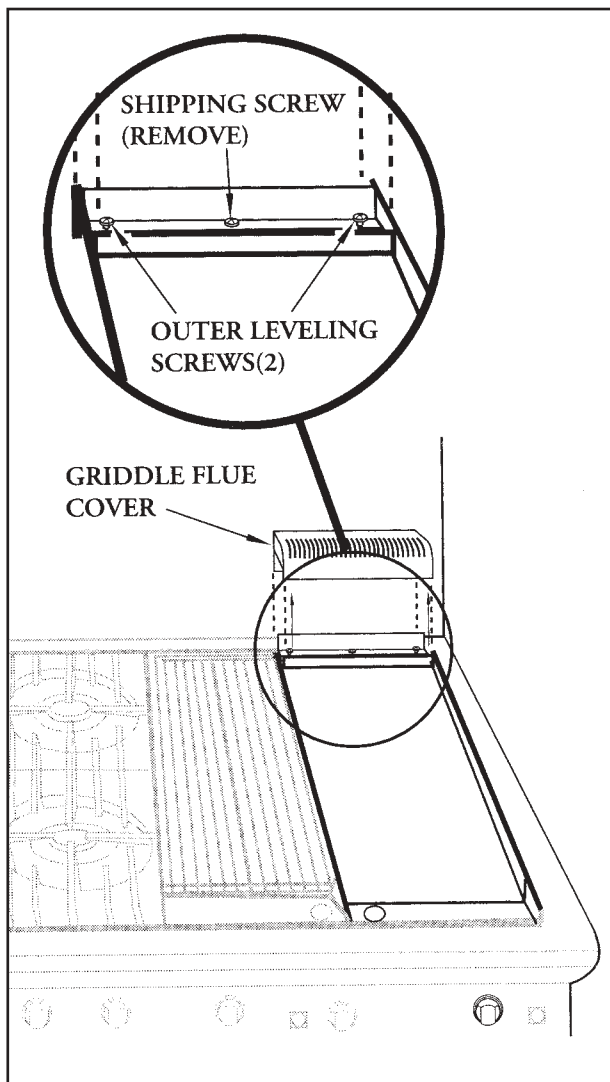

The built-in griddle on your cooktop is made from Type 304 stainless steel, highly polished to provide a smooth cooking surface. It is normal for it to darken with use as oils cook onto the surface to provide a stick resistant base or “seasoning”. Since the griddle is made from stainless steel the surface will not rust.

The griddle burner is thermostatically controlled and cycles on and off to maintain the set temperature. The “HEATING” light indicates that the burner is “on”.

The griddle assembly is not to be removed for cleaning and is held in place by two front screws and one rear screw. These are mainly there to keep the griddle from shifting in transit and positioning thus avoiding breakage of any igni-

tion components. Once the unit is in position the rear shipping screw can be removed. It is located beneath the griddle flue cover which is removed by lifting off (be careful not to scratch your backguard during removal of the cover). Remove the center shipping screw.

The two outer screws are leveling screws. They can be turned to level the griddle or to provide a forward slope to help grease and oils to drain away from the food being cooked. After using the griddle a few times you will be able to judge the slope best for the foods you are cooking and your personal preference.

BEFORE USING THE GRIDDLE FOR THE FIRST TIME or TO RESEASON

1. Clean the griddle thoroughly with hot, soapy water to remove any protective coating.
2. Rinse with a mixture of 1 quart water and /cup white vinegar. Dry thoroughly.
3. Pour 1 teaspoon vegetable oil into the center of the griddle (do not use corn oil as it gets sticky). Rub the oil over the entire surface of the griddle using a heavy cloth.
4. Turn the control knob to a Medium setting (350°F). Turn the heat Off when the oil begins to smoke. Allow the griddle to cool.
5. Repeat Step 3. Be sure to cover the entire surface with the oil.
6. Repeat Step 4. Allow the griddle to cool. Wipe the entire surface of the griddle using a heavy cloth. Apply a very thin layer of vegetable oil. The griddle is now ready to use.

If the griddle is not used for a period of time, reseason it occasionally.

NOTE: It is normal for the griddle to darken with use.

GRIDDLE USE

GRIDDLE COOKING CHART

FOOD	TEMPERATURE
Eggs	225°F to 250°F
Bacon, Ham, Pork Chops	300°F to 325°F
Sausage, Grilled Cheese Sandwiches	325°F to 350°F
Pancakes, French Toast	350°F to 375°F
Hash Brown Potatoes	400°F to 425°F

USE OF THE GRIDDLE

Before starting to cook on the griddle, be sure the drip tray and liners are in place. Preheat griddle for 15 minutes with the control knob set to the temperature suggested on the cooking chart. When the grill is preheated, the HEATING light will turn off. Place the food on the griddle and cook to desired doneness.

NOTE: When the griddle is properly seasoned it can be used without any additional shortening. However, it can be used for flavor. A light mist of non-stick vegetable spray, applied before cooking to a cool griddle, makes delicate foods easier to turn.

USE THIS SPACE TO SAVE GRIDDLE NOTES AND YOUR FAVORITE RECIPES:

OVEN USE

OVEN COOKING ELEMENTS

Your new professional Dual Fuel range is equipped with bake and broil cooking elements. The 27" oven bakes at 6,000 Watts while the 27" and 24" oven broils at 4,000 Watts. On the (RD 304 models) the 24" oven bakes at 3,000 watts. The 12" proofing oven (*RD 48 models only*) bakes at 3,700 Watts and broils at 3,600 Watts.

OVEN

Your 27" and 24" (*on RD304 Models*) new oven (single or right side) can be used in three cooking modes; convection bake, regular bake or broil. To help you decide which way to cook your food read this information first. Remember this is a new oven and the thermostat has been checked for accuracy. Your old oven may have had a thermostat that over the years got a little hot or a little cold. Check your recipes for the correct time and temperature. Use caution when using your old ovens time or temperature. You may have been compensating for your old oven being out of calibration.

Models DCS RD 484 GG, DCS RD 486 GL and DCS RD 486 GD have two ovens. The 27" oven on the right side can be used for standard baking, fan assisted convection baking, and broiling. It is also self-cleaning. The 12" oven on the left side, can be used for standard baking, broiling, and proofing baked goods. It is also ideal for baking small amounts of food when you don't want to heat the large oven.

CONVECTION BAKING

Convection Baking is baking using the fan at the back of the oven for circulating the hot air in a continuous pattern around the food. This circulating hot air heats and browns the surface of the food more effectively than in a standard oven. This allows most foods to be cooked at lower oven temperatures or in less time, if baked at the regular temperature. The air is recirculated and reheated. Uncovered, longer cooking foods such as large pieces of meat or other foods that can be cooked in low sided baking utensils or air leavened foods, are where you will see the most savings in cooking time. Using multiple racks (3) at the same time will achieve a good time saving, as you can cook more food at the same time. The number of recipes requiring preheating of the oven is reduced considerably because the heat reaches the food faster as the hot air circulates around the food.

Foods Suitable to Cook by Convection

Air Leavened Foods (Angel Food Cake, soufflés, cream puffs, meringue shells)
Appetizers
Breads
Main Dishes
Oven Meals (1 to 3 racks)
Cookies
Poultry
Roasts

REGULAR BAKING

Bake is baking with hot air; there is no fan. The air movement comes from natural convection - as the air heats, it moves to the top of the oven. This oven mode is the same as you have been using for baking on one or two racks.

Foods Suitable to Cook by Bake

Appetizers
Pies, Cakes
Breads
Desserts
Main Dishes
Oven Meals (1 to 2 racks)
Poultry
Roasts

BROIL

Broiling is cooking by intense infrared radiation supplied by the broil burner element located at the top of the oven. Since broiling is cooking by radiant heat it is not necessary to use the convection fan in the broil mode.

Foods Suitable to Cook by Broil

Appetizers
Meats, Poultry, Fish
Top Browning: Casseroles, Breads

OVEN USE

Converting Recipes to Convection Baking

Low sided baking utensils will give the best results as the hot air can reach all sides of the food easier. The oven temperature can be left the same as the recipe and the food cooked a shorter period of time. The temperature can be lowered 25°F to 50°F and the food will probably take the same length of time to cook as the recipe states. If you find that food is adequately browned on the outside, but not done in the center, lower the temperature another 25°F and add to the baking time. When reducing the temperature **always check the food for doneness, a minute to two before the minimum time** stated in the recipe, as time can always be added. Some recipes will cook faster than others. There is no way to predict exactly how long each recipe will take when you convert it to convection. Convection will be easier to use after you have used it a few times as you will begin to understand the way it bakes.

Selecting Utensils for Convection Baking

Cooking by convection does not require any specially designed baking utensils. You probably have many utensils in your kitchen that are suitable to use. When choosing a baking utensil, consider the material, the size and the shape as they all affect the baking time, the palatability and the appearance of the finished product.

Metal bakeware (aluminum, steel and cast iron) all result in the fastest cooking time and the best end product. Aluminum pans work well for all types of baked goods. For the best browning, use a pan with a dark or dull finish that absorbs heat, when baking pies and breads. A shiny finish works best for cakes and cookies, since it reflects some of the heat and provides a less intensive cooking surface. Cookie sheets with only one edge will give the best results, as the heated air can circulate all around the sides of the food. For roasting use the bottom of the broil pan and elevate the meat on a metal roasting rack. Glass-ceramic or glass utensils do not conduct heat as well as metal, but they can be used. Use them for foods that do not require a dark brown crust or crisping, such as soufflés.

Baked items cook more quickly and evenly if they are individually smaller in size, i.e. two or three small foods do better than one large piece. When single food items are baked, always center the food on the rack. If several foods are being baked, space them evenly on the rack or racks.

CONDENSATION

During any cooking process there is a certain amount of moisture that evaporates from the food. The amount of moisture that condenses on the oven depends on the moisture content of the food. The moisture will condense on any surface that is cooler than the inside of the oven. While baking with an extremely moist food product in the oven, condensation may collect on the control panel or the top of the door.

TO GET THE BEST RESULTS

Baking

- Follow the recipe amounts and ingredients, including the size and shape of the baking utensil recommended in the recipe.
- Do not open the oven door often, use the interior oven light and look through the window. All Dual Fuel ovens have been designed with large windows for easy bake checks.
- Do not use the oven for storage, especially when baking in the oven. Extra utensils, not being used for baking, can affect the food product, the baking time, the browning and end result.
- If you are using glass utensils, lower the temperature 25°F.
- Use a minute timer, set it for the minimum time suggested in the recipe.

Convection Baking

- Follow the first three recommendations above.
- Metal utensils give better results in convection, than glass baking utensils. If you use glass, it usually is not necessary to lower the temperature an additional 25°F.
- Use a minute timer, set it for less than the minimum time suggested in the recipe, the first time you use a recipe in the convection mode. Be sure to note the new baking time on your recipe, for future reference.
- Be sure to read the basic information on convection before using the oven for the first time.
- Keep in mind that convection baking results vary, depending on type of product. In many cases, standard bake yields superior results over convection.

OVEN USE

SETTING BAKE/CONVECTION BAKE FOR THE 27" & 24" MAIN & 12" PROOFING OVENS-

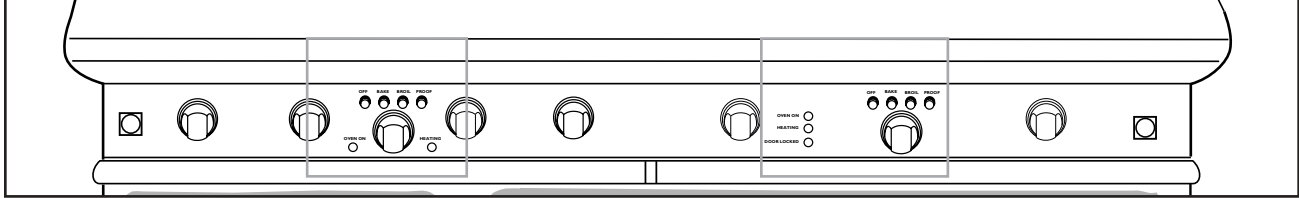

PREHEATING

Preheating takes about 10 to 15 minutes depending on the temperature set. Preheating is usually necessary for foods baked at high temperature for a short period of time, i.e. drop cookies. The oven heating light will turn off when the oven has reached temperature.

SETTING THE 12" OVEN FOR BAKING:

(48" Models Only)

To use the 12" Proofing Oven to bake (smaller oven on left side), simply push in the "BAKE" switch on the valve panel, above the Oven knob over the small oven and turn the control knob to the temperature used in the recipe.

12" PROOFING OVEN BAKE CONTROL

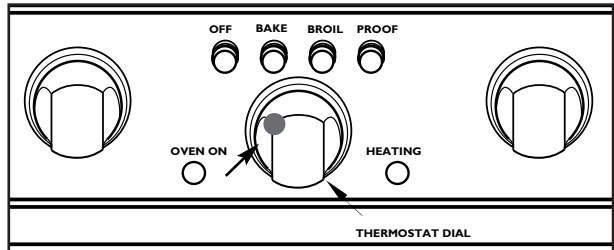

- 1) With the Thermostat Knob "OFF", Press **BAKE** Selector button (see fig. above)
 - The "OVEN ON" light turns on.
 - The "HEATING" light turns on.
 - Once the "HEATING" light cycles off the first time, the Oven is preheated.
 - The "OVEN ON" light remains on until the "OFF" Selector button has been pushed, or the Thermostat has been turned to the "OFF" position.
- 2) Set desired **Temperature** on Thermostat Dial.

SETTING THE 27" & 24" OVEN FOR BAKING:

Decide if you are going to use **BAKE** or **CONVECTION BAKE**. These cooking modes are for baking, roasting or warming using one, two or three racks. If you are going to use regular Bake simply push in the "BAKE" switch on the valve panel, above the Large Oven knob and turn the control knob to the temperature used in the recipe. To use Convection Bake push the Convection Switch (located on the Control Panel) and turn the control knob to the temperature desired.

27" & 24' OVEN BAKE/CONVECTION BAKE CONTROL

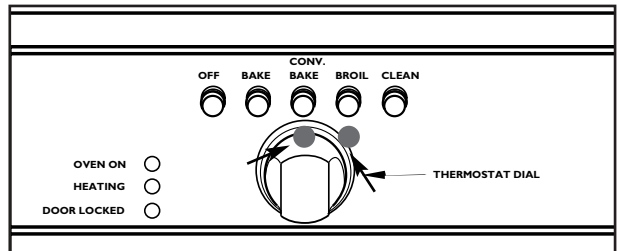

- 1) Press **BAKE** or **CONVECTION BAKE** Selector button (see fig. above)
 - The convection fan will turn on if "CONVECTION BAKE" is selected.
- 2) Set desired **Temperature** on Thermostat Dial.
 - Once the "HEATING" light cycles off the first time, the Oven is preheated.
 - The "OVEN ON" light remains lit until the "OFF" Selector button has been pushed, or the Thermostat has been turned to the "OFF" position.

OVEN USE

27" and 24" Oven Ranges:

The larger 27" self cleaning convection oven is located on the right side of a 48" Dual Fuel Range or is the only oven on a 36" and 30" Range. The oven comes standard with (3) oven racks and three position roller assisted rack supports. A porcelainized steel broiler pan is included with this oven.

A note about the roller assisted rack supports (27" and 24" oven only):

Specifically engineered from high temperature materials for in oven use, they will stand up to years of use. They are especially functional when the oven racks are supporting the heavy food products associated with this high capacity oven. They must be removed before the oven can be put into self clean. *See page 27 for care of the rack supports.* All three dual fuel ovens come with a 2-pc. broil pan.

12" Oven (48" Ranges Only):

The 12" oven comes equipped with (2) oven racks and three position rack supports. The rack supports are removable for cleaning. Also included is an aluminum broil pan and porcelainized steel bottom pan for easy cleaning.

CAUTION: Aluminum foil should never be used to cover the oven racks or to line the oven bottom. The trapped heat can damage the porcelain and the heated air cannot adequately reach the food being baked.

Baking

One or two racks can be used simultaneously during bake. Place the rack/s in the desired position before turning the oven on. Store any unused racks out of the oven.

Rack position 2 (second from bottom) will probably be used the most, for single rack baking.

If you are using two racks simultaneously, be sure to check the food on the bottom rack sooner than the minimum time. The food on the lower rack position may cook slightly faster than the food on the upper rack, particularly if you are using large baking utensils.

If you are using two racks simultaneously, be sure to stagger the baking utensils so that one is not directly above the other and the heated air can circulate freely around each pan. Allow at least 1" of space between the oven walls and the pans.

If using large or commercial size baking utensils, the food may take a few extra minutes as the air cannot circulate as freely as it does with a smaller pan. When using commercial size baking utensils, use only one rack as the heat does not have the room to circulate.

Convection Baking

One to three racks can be used simultaneously during convection baking. Place the racks in the desired position before turning the oven on. Store the unused racks out of the oven.

Rack position 2 (second from bottom) will probably be used the most, for single rack baking.

When baking on more than one rack you do not need to stagger the pans. However, allow at least 1-inch of space between the oven walls and the pans so the heated air can circulate.

HIGH ALTITUDE BAKING

Recipes and baking times vary if you are baking at a high altitude. For accurate information write to the Agriculture Extension Service, Colorado State University, Fort Collins, Colorado 80521. Specify the type of information and the baking mode (convection bake or bake) you need i.e. cakes, cookies, breads, etc. There may be a cost for the bulletins.

OVEN USE

BROIL

TO SET THE OVENS FOR BROILING

When the "Broil" selector button is pressed you will hear a cooling fan begin to operate and feel an air current above the oven door. This air current serves to keep the control area above the oven cooler during open door broiling. The cooling fan must be running for the broiler to operate. Never open door broil with children nearby. See "Safety Practices".

12" Proofing Oven:

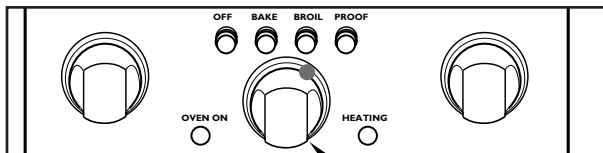

27" and 24" Main Oven:

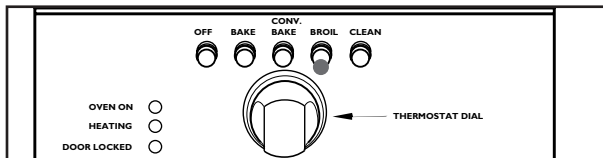

PREHEATING

The broiler does not need to be preheated for most broiling. However, fast cooking foods such as thin strips of meat or fish may require a short preheating period of 2 to 3 minutes to allow the food surface to brown in the same time the food takes to be cooked throughout.

TO GET THE BEST RESULTS

- Defrost the food before starting to cook.
- **Leave the door ajar at the broil stop**
(* NOTE- If the door is closed during broiling, the oven cavity may get hot enough to cycle the broil element on and off, producing food that tastes baked/roasted instead of broiled.)
- Set a minute timer for the minimum time to check the food.

Steaks should be at least one inch thick, if a rare doneness is desired. It is difficult to get rare with meat that is thinner, or to get a nice brown piece of meat.

- After half the total cooking time turn the food over only once. It is not necessary to turn over thin foods (fillet of fish, ham slices, etc.). Liver slices must be turned over.
- When top browning use metal or glass-ceramic bakeware. **DO NOT** use heat-proof glass or pottery as this type of glassware cannot withstand the intense heat of the broiler burner.

NOTE: You cannot use the broiler burner and the bake burner at the same time. When one is on, the other cannot be turned on.

USING A MEAT THERMOMETER TO BROIL

To accurately determine the doneness of a thick steak or chop (1½ inches thick or more), use a meat thermometer. Insert the point of the thermometer into the side of the meat to the center. Cook the first side to 90°F for rare meat. Cook the first side to 100°F for medium to well done. Cook the second side to the desired degree for the doneness you want, 135° F to 140°F for rare, and 150°F to 155°F for medium and 160°F to 165°F for well done. If you are cooking pork, cook to 170°F.

A large two-piece broil pan comes with your new range. When you are broiling, always use both pieces. Do not cover the grid with aluminum foil. This slotted grid allows the grease drippings to flow into the bottom of the pan keeping it away from the intense heat of the infra-red broiler burner. This helps to minimize the smoking and spattering of the grease.

NOTE: When the oven is used for an extended period of time at a high temperature, the cooling blower may turn on. This is normal. The cooling blower will also operate during Broil and the Self-Cleaning cycle. **If the blower is not running during these modes, do not use the oven.** Call a qualified appliance technician to repair the unit.

OVEN USE

OVEN RACK POSITION

The rack position depends on the type and thickness of the food. Thick pieces of meat or poultry would typically be broiled on rack position 2, steaks, chops and hamburger, would be broiled on rack position 1. If top browning casseroles or bread the thickness of the food would indicate the rack position. The casseroles would typically be browned on rack position 2 or 3 and the bread on rack position 1. (*see p.7 for Rack position illustration*)

TO USE THE OVEN FOR SLOW COOKING OR LOW TEMPERATURES

The oven can be used to keep hot food hot, to dehydrate food, to warm plates, for slow cooking (as in a crock pot), and to defrost foods.

You can keep hot, cooked food at serving temperature. Set the oven to the temperature suggested in the chart. Rare meat must be eaten when it is removed from the oven, as it continues cooking from its own heat.

To keep food moist, it must be covered with aluminum foil or a lid.

To dehydrate food, follow suggestions in a recipe.

To warm plates, check with the dishware manufacturer for the temperature for the recommended.

To use the oven as a slow cooker set the oven control knob to 225°F, place the food in the oven in a pan with a tight fitting lid. Follow recipes for this type of cooking.

To thaw uncooked frozen food, set the oven control knob for 150°F. Be sure the food is tightly wrapped in foil. Thaw the food just enough to handle it. Cook immediately. Do not refreeze.

To thaw frozen cooked food, set the oven control knob to 170°F. Loosen the freezer wrapping. Do not use plastic wrap or wax paper in the oven.

FOOD SAFETY

According to the United States Department of Agriculture you should not hold foods at temperatures between 40°F to 140°F for longer than 2 hours.

SUGGESTED TEMPERATURES TO KEEP FOOD HOT

Food	Oven Temperature
Beef	
Rare	150° - 155°F
Medium	155° - 170°F
Well Done	170° - 180°F
Bacon	200° - 225°F
Biscuits and Muffins (covered)	170° - 185°F
Casserole (covered)	170° - 200°F
Fish and Seafood	170° - 200°F
French Fried Foods	200° - 225°F
Gravy or Cream Sauces (covered)	170° - 180°F
Lamb and Veal Roasts	170° - 200°F
Pancakes and Waffles (covered)	200° - 225°F
Potatoes	
Baked	200°F
Mashed (covered)	170° - 185°F
Pies and Pastries	170°F
Pizza (covered)	225°F
Pork	170° - 200°F
Poultry (covered)	170° - 200°F
Vegetables (covered)	170° - 175°F

12" PROOFING / 27" & 24" SELF-CLEANING

12" OVEN PROOF MODE

This feature of the 12" Proofing Oven maintains a warm, non-drafty environment useful for proofing yeast leavened products.

SETTING THE 12" OVEN FOR PROOFING:

- 1) Place dough in dish in the small oven.
- 2) Press "PROOF" Selector button

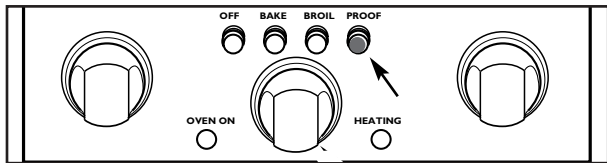

- The "OVEN ON" light and oven interior lights turn on.
 - The "HEATING" light will **not** turn on in the proofing mode. The thermostat dial setting does not effect the proof temp.
 - The ideal temperature for proofing will be maintained until the "OFF" button is depressed.
- 3) Set a Minute timer for the minimum proof time.

NOTES: A) Do Not Open the Oven Door unnecessarily as doing so will lower the oven temperature and lengthen proofing time.

B) Proofing time may be decreased when using the large oven at the same time you are proofing. Check bread product early to avoid over-proofing. If you are using the large oven for extended periods of time, we recommend, for optimum results, that you complete the proofing before turning the large oven on.

⚠ **DO NOT USE THE PROOFING OVEN FOR WARMING FOOD OR KEEPING FOOD HOT. THE PROOFING OVEN TEMPERATURE IS NOT HOT ENOUGH TO HOLD FOODS AT SAFE TEMPERATURES (above 140°F)**

12 " PROOFING OVEN CONTROL KNOB

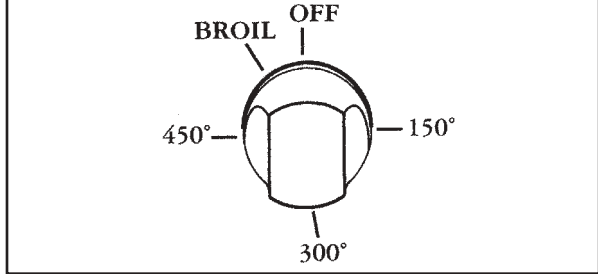

27" & 24" OVEN SELF-CLEANING

The self-cleaning oven of your new range features pyrolytic self-cleaning. When set in the CLEAN mode, the oven reaches a high temperature that burns off the food soil.

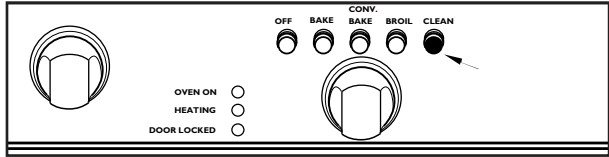

When the oven is set for CLEAN, only the cooktop burners (four or six) may be used. The 12" Electric Proofing Oven, the griddle and/or the grill cannot be used.

It is common to see smoke and/or flames during the CLEAN cycle, depending on the content and amount of soil remaining in the oven. If a flame persists, turn off the oven and allow it to cool before opening the door to wipe up the excessive food soil.

At the end of the clean cycle, some gray ash or burned residue may remain inside the oven. This is a mineral deposit that does not burn or melt. The amount of ash depends on how heavily soiled the oven was before the oven was cleaned. It is easily removed, once the oven has cooled, using a damp paper towel, sponge, or cloth.- Continue on next page...

27" & 24" OVEN SELF-CLEANING

Wipe off any smoke residue that remains on the front frame with Formula 409® and Fantastik®. If stain remains, use a mild liquid cleanser. The amount of smoke stain is directly related to the amount of food soil left in the oven at the time of self-cleaning. Clean the oven often.

OVEN DOOR LOCK DURING SELF-CLEAN

When the clean cycle starts, the lock light turns on, and the automatic door lock cycle begins. Do Not attempt to open the door when the lock light is on. You can stop the cycle by pushing the off button. The lock light will turn off only after the oven has cooled below 550°F, and the automatic door lock has completed its cycle to the open position.

BEFORE SELF-CLEANING THE OVEN:

- ✓ Remove all utensils.
- ✓ Clean the oven front frame and outer door edges. Wipe up large spillovers and grease. (see below)

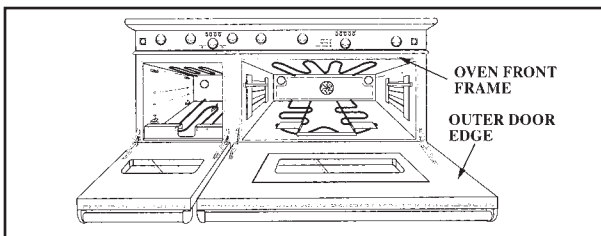

- ✓ Be sure the light bulbs and glass covers are in place. (see page 6- item #26)
- ✓ Turn on the ventilator hood above the range and leave it on until after the oven has completed the self-clean cycle.
- ✓ Remove Oven Racks and Rack Slide Assemblies

(NOTE: An *Interlock System* has been designed so that the Self-Clean Cycle will not engage until the Rack Slide Assemblies have been removed. *The roller assisted rack supports are designed to withstand the temperature range of the standard baking thermostat. They will not withstand the extreme temperatures of pyrolytic self cleaning.* To remove the Assemblies; A) For each side, Remove the retaining screw, B) Lift up slightly and pull the entire Assembly out. Set aside.)- Replace the assemblies and retaining screws after the Self-Clean cycle has finished. (see illustration below)

27" OVEN RACK SLIDE ASSEMBLY:

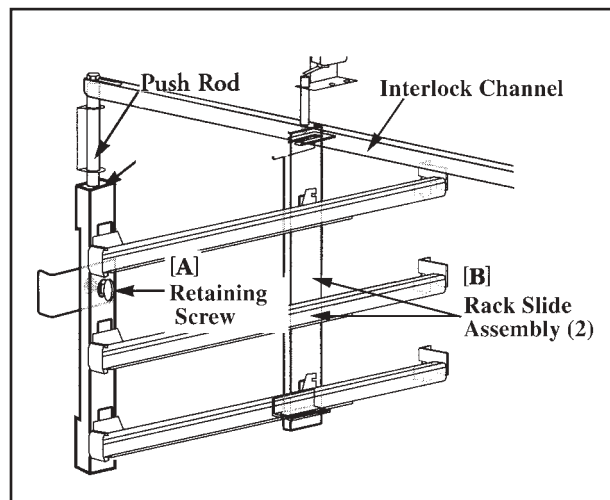

Wipe out puddles of grease and any loose soil that can be easily removed.

Remove any soil that is outside the door seal area. This appliance is designed to clean the oven interior and that portion of the door that is inside the oven. The outer edges of the door and the oven cavity are not in the cleaning zone. Wipe this area clean BEFORE SETTING THE OVEN TO SELF-CLEAN.

27" & 24" OVEN SELF-CLEANING



Turn on the ventilator hood above the range and leave it on until after the oven has completed the self-clean cycle.

SETTING THE 27" & 24" OVEN FOR SELF-CLEANING:

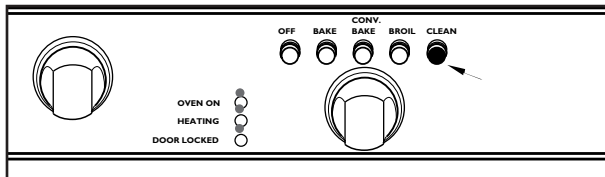

- 1) Push the "CLEAN" Selector Button.
- 2) Set Thermostat to "CLEAN".
 - *Cooling Blower turns on,*
 - *OVEN ON light and HEATING light turn on,*
 - *LOCK light turns on,*
 - The door closing process takes approximately 60 seconds to complete, at which time the door becomes locked.

AT THE END OF THE CLEAN CYCLE:

The Clean cycle takes 4 to 5 hours to complete. The blower and the OVEN ON light turn off once the cycle has finished.

- 1) Push the OFF Selector Button.

The door latch will open automatically after the oven temperature falls below 550°F and the automatic Door Lock completes its 60 sec. cycle to the OPEN position.

- 2) Turn the Thermostat to OFF

- 3) Replace the oven rack slide assemblies by A) Guiding the rear of the rack slide assembly into the bottom rear bracket of the oven side, B) Guide the top rear of the rack slide assembly into the top U-shaped bracket of the oven side, C) Lift up the Push Rod so that it rests on the "ledge" of the side support of the assembly, and D) Screw the assembly secure to the oven through the hole in the front middle section of the side support. Repeat for the other side of the oven.

(SEE ILLUSTRATION BELOW)

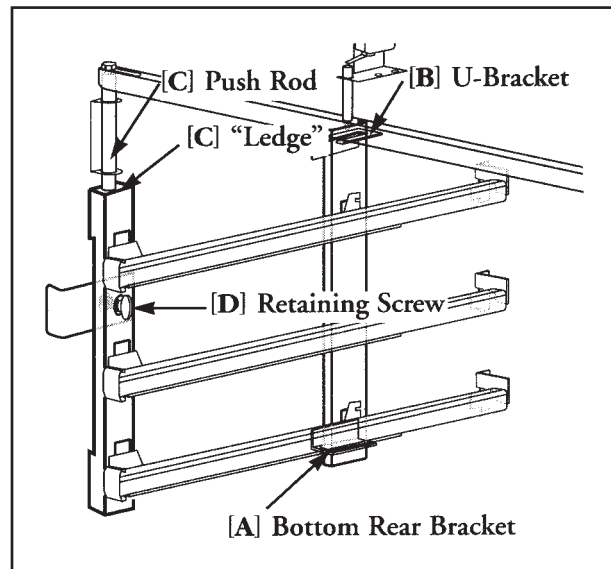

CAUTION: *The interior of the oven will still be at baking temperatures when the lock light turns off and the oven door can be opened. Use caution as the Oven may be hot enough to cause burns.*

CARE and MAINTENANCE

When cleaning this range:

Be careful cleaning any part of this appliance particularly the griddle or the grill while hot.

All parts of the appliance (except the stainless steel griddle) can be cleaned with hot soapy water, rinsed, dried and buffed to a shine with a soft, heavy pile cloth. Always try this first, as it is the mildest cleaning procedure.

1. Use the mildest cleaning procedure first. Some brands of cleaners of the same type are harsher than others, read their directions. A scent or a propellant can make a difference in the product, read the ingredients. Try on a small area first.
2. To avoid marring the surface always rub metal finishes in the direction of the polish lines. The cleaner will be more effective when used in the direction of the polish lines.
3. Use only clean sponges, soft cloths, paper towels, plastic non-metal or steel wool soap pads for cleaning or scouring (use only soap pads with soap still in them, an empty pad can scratch), as recommended in this section.
4. Be sure to rinse all parts thoroughly and to wipe dry to avoid water marks.

Brand Names

In this section on cleaning, the use of name brands is intended only to indicate a type of cleaner. This does not constitute an endorsement. The omission of any name brand cleaner does not imply its adequacy or inadequacy. Many products are regional in distribution and can be found in the local markets and department stores.

COOKTOP

Turn off all the burners and allow the grates to cool, before starting to clean the cooktop. Clean the griddle or the grill very carefully, while still hot, see directions. If you wipe off any part of the cooktop while it is hot do so carefully as using a wet sponge or cloth can result in steam burns.

BURNER GRATES

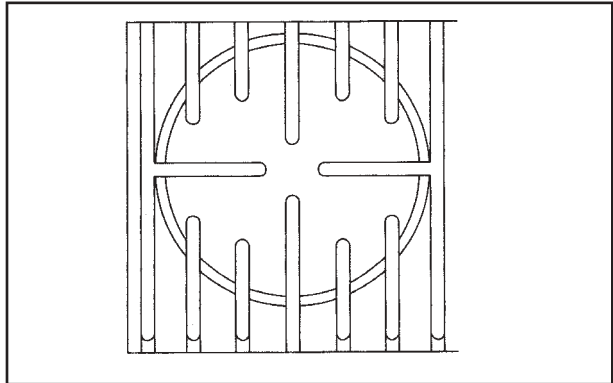

When lifting the grates be careful as they are heavy. Place them on a protected surface, so they won't scratch the surface they are laid on.

The burner grates are porcelain enamel over cast iron. When cool they may be placed in the dishwasher, or wiped clean while on the cooktop using hot soapy water, then rinsed and wiped dry.

The occasional use of mild abrasive cleansers such as Bon-Ami[®], Soft Scrub[®] or a soap-filled steel wool pad is okay. Abrasive cleansers, used vigorously or too often, can eventually harm the enamel. Apply with a damp sponge, rinse thoroughly and dry.

The porcelain may pop off the edge of the grates due to rapid temperature change when the burners are turned on. Do not be concerned as this does not result in the deterioration of the grates. The cast iron soon darkens to blend with the porcelain enamel. Be careful when wiping an area where the porcelain has popped off, as the edges may be sharp.

BURNERS

For proper lighting and performance keep the burners clean. It is necessary to clean the burners if they do not light even though the igniter clicks, if there has been a severe boil over or when the flame does not burn blue.

The burners have been designed in two pieces for ease in cleaning. When the burner grate and the burner are cool, remove the grate. The burner cap and the port ring can easily be lifted off. Wash these parts in hot soapy water, rinse and dry thoroughly. The port ring and the burner cap are porcelain enamel, follow the directions above.

CARE and MAINTENANCE

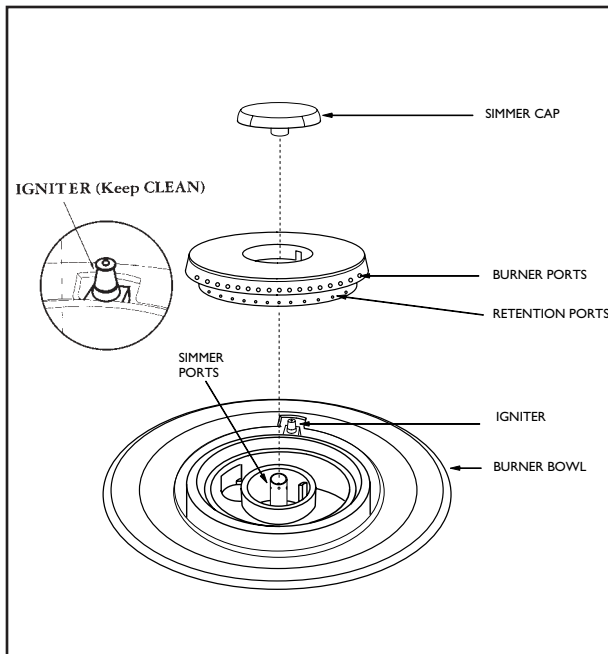

IGNITERS

Wipe with a water dampened cotton swab. Be careful not to damage the igniter. (See illustration above and page 9.

BURNER BOWLS

The burner bowls, around the burners, are easily lifted off when the burner grates are removed. They are porcelain enameled steel. Clean following directions for burner grates.

DRIP TRAYS, DRIP TRAY LINERS, DRAIN TUBES

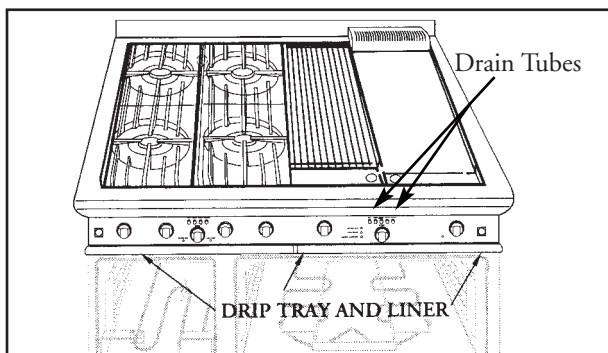

Located beneath the cooktop is one or two drip trays (depending on model). If you have a griddle or a grill there will also be a tray liner. The drip trays and liners are made

of stainless steel. The drip trays are on rollers so they are easy to remove and replace. To remove, pull the tray forward. If something has spilled into the trays it should be cleaned up as soon as possible to prevent “baked on” food soil.

Grease from the griddle or the grill drains through the drain tube into the tray and liner below. **Do not allow the grease to accumulate** in the tray or liner as it can be a fire hazard. Clean the tube, tray and liner as soon as they are cool. Clean with hot soapy water. For the tube use a soapy bottle brush. A mild abrasive cleaner such as Bon-Ami or Soft Scrub can be used. For stubborn stains use a soap filled steel wool pad, or a harsh abrasive such as: Comet[®] or Ajax[®], rubbing lightly. Rinse all parts thoroughly.

GRIDDLE

Thoroughly clean the griddle of grease and food particles, using a square edged spatula, while it is still hot. Once the griddle has cooled to a lukewarm temperature rub the surface lightly with vegetable oil (do not use corn oil, it gets sticky). Thoroughly wipe the griddle with a heavy coarse cloth or burlap to remove any remaining residue and food particles.

If you have a **grease build-up** use 1 tablespoon of vinegar in a 1/2 cup of water, clean with a scouring cloth such as a Chore Boy[®] Scouring Cloth. For **heat discoloration** use a stainless steel cleaner for heat stains such as Revere Ware[®] Stainless Steel Cleaner.

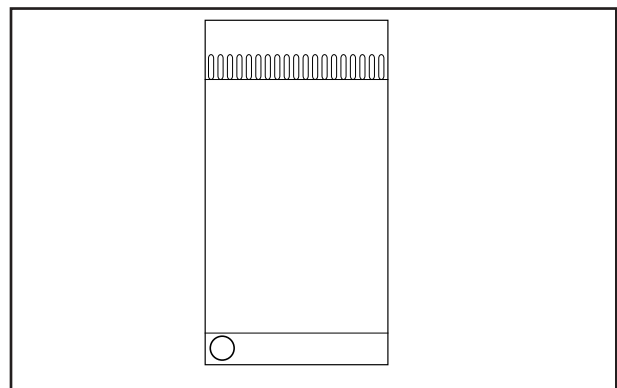

Wash with hot soapy water, rinse and dry. If **food soil or residue** is cooked onto the griddle, use a griddle stone (fine grained pumice), or a griddle pan and screen cleaner (these are both available at restaurant supply store), following the manufacturers’ directions. Wash with hot soapy water, rinse and dry.

CARE and MAINTENANCE

If hot soapy water, vinegar, scouring powder, steel wool or metal scouring pads are used to clean the griddle, it **must be reseasoned**. Follow the directions on page 14 to reseason the griddle.

⚠ **NEVER FLOOD THE HOT GRIDDLE WITH COLD WATER.** This could cause the griddle to crack or warp.

GRILL

Clean the grill immediately after cooking. Turn off the burner. To protect your hand from steam and heat, wear a barbecue mitt. Scrub the grill by dipping a brass bristle barbecue brush frequently into a bowl of water. The steam created softens the food particles and assists the cleaning process. The food particles will drop into the drip tray or into the radiant tray holding the briquettes. Be sure to clean the drain tube, drip tray and liner after they have cooled. Follow directions above.

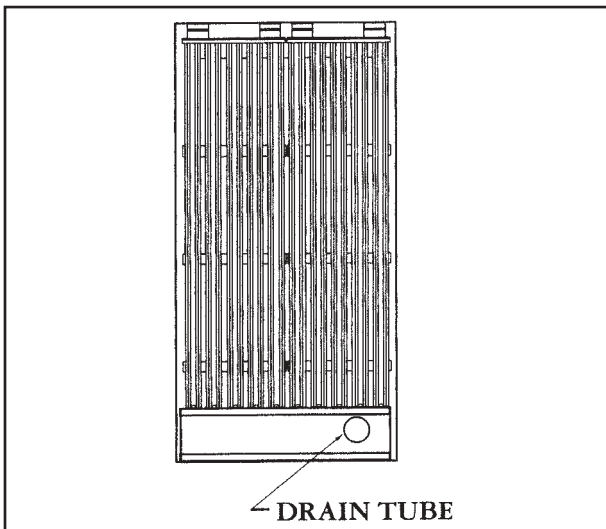

The Radiant Tray and briquettes, should be removed periodically (when cool) and shaken over a layer of newspaper, which can be thrown away.

CONTROL KNOBS - Cooktop, Griddle, Grill and Oven

Cooktop:

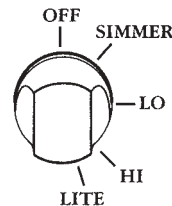

Large Oven:

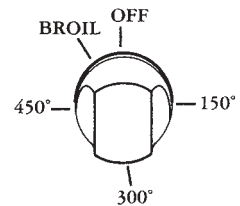

Grill:

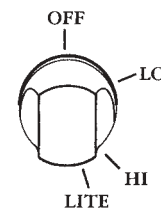

Griddle/ Sm. Oven

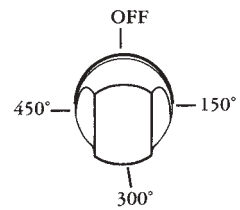

These are plastic and can be cleaned in hot, soapy water. To remove the knobs from the control panel, grasp the knob and pull straight back towards you and away from the grill. Wash, do not soak. Rinse and dry thoroughly. It is important to replace these knobs on the correct gas valve, on the control panel.

The cooktop and grill control knobs are similar, the cooktop knobs have a setting for "Simmer", the grill does not. The oven and griddle control knobs are similar, they both have temperatures on them, oven knob has a "Broil" setting, the griddle does not.

BACK PANEL and SHELF

This is made of stainless steel. Use the mildest cleaning procedure first. Hot soapy water, rinse and dry. If the panel has food soil remaining, try a general kitchen cleaner, such as Fantastik®, Simple Green® or Formula 409®. For hard to clean soil use a stainless steel cleaner such as, Bon-Ami, Cameo®, or Bar Keepers Friend. Apply cleaner with a damp sponge, rinse thoroughly and dry. Always scrub lightly in the direction of the grain. **Do not use a steel wool pad**, it will scratch the surface. To touch up noticeable scratches in the stainless steel, **sand very lightly** with dry 100 grit emery paper, rubbing **in the direction of the grain**. After cleaning use a stainless steel polish, such as Stainless Steel Magic®.

CARE and MAINTENANCE

If the rear top burners are used extensively on high it is possible for the vertical stainless steel panel of the low back or high shelf to discolor from the burner heat. This discoloration can be removed by using Revere Ware Stainless Steel Cleaner.

OVEN and DOOR INTERIOR

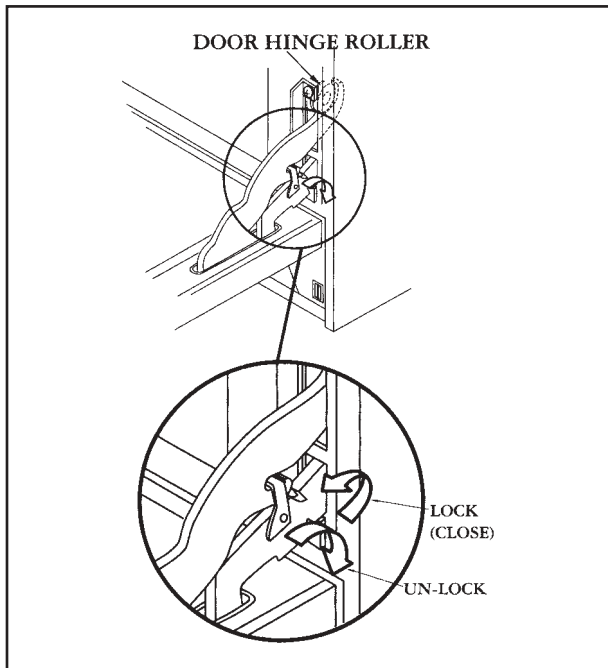

If in the event the oven door comes off track, or becomes misaligned, realignment can be achieved by following this simple procedure: Open the door and hold it all the way open. Close the hinge latches. (*see illustration*) Once both hinges are locked, gently lift the door up and partially out until the door is evenly aligned. Evenly slide the door back into place and check to assure the hinges rest in the center of each door hinge roller. With the oven door fully open, unlock hinge latches and the door is ready to close again.

Be sure the oven and door are cool before you start to clean them. They are porcelain enamel. It is acid resistant, but not acid proof. Therefore, acid foods, such as vinegar, rhubarb, alcohol, citric juices or milk, should be wiped and not allowed to bake on.

Try **mild cleaners**, such as: Bon-Ami, ammonia or ammonia and water or Soft Scrub. Apply the powders on a damp sponge or cloth. Rub lightly. Rinse thoroughly and dry. If

food has burned onto the oven and is difficult to remove, soak the spots with a cloth saturated with household ammonia. Allow it to soak for an hour or two, with the door closed. The food soil should be easy to remove with a damp soapy cloth or mild abrasive.

A solution of 3 tablespoons ammonia in a 1/2 cup of water may be placed in a warm (not hot) oven over night. This loosens the spills and hardened residue so they are easily wiped up with a clean damp sponge or cloth.

For **stubborn stains** a soap filled steel wool pad can be used. The **occasional use** of abrasive cleaners is okay, if used too often or vigorously they can eventually harm the enamel. Dampen the pad, rub the surface lightly, rinse thoroughly and dry.

Do Not use Oven Cleaners (such as Easy Off® or Dow®) on the oven interiors or rack slide assemblies / rack supports. Commercial oven cleaners are corrosive to the thermostat bulb and heating elements. Do not spray or wipe this type cleaner onto the oven thermostat bulb or heating elements. *If some cleaner gets onto the bulb or broiler burner, wipe it off immediately with a clean damp cloth.*

OVEN RACKS and RACK SLIDES

All of the oven racks and 12" rack supports are chrome plated steel. **The roller assisted rack supports in the main oven are stainless steel.* To remove the 12" Oven rack supports, first remove the oven racks, then grasp the rack supports and pull up and out. To replace the rack supports, put the top in first. **See page 22 for removal of the self cleaning Oven Roller Assisted Rack Support Assemblies.*

Do Not immerse the self cleaning Rack Slide Assemblies or wash in a dishwasher. Use a damp sponge, cloth, or steel wool with a mild detergent to clean.

Chrome cleaners, such as Soft Scrub, Cameo or Bar Keepers Friend can be applied with a damp sponge following package directions. Rinse and dry. **Powdered cleaners** such as Bon-Ami or Comet are applied with a damp sponge or cloth, rubbed lightly, rinsed and dried. For hard to remove food soil use a dampened soap filled steel wool pad, rinsed and dried. **Harsh Cleaners** which are commercial oven cleaners, such as Easy Off or Dow can be used on the racks, but are not recommended for use on the self cleaning oven rack slide assemblies or oven interiors. Additionally, some commercial oven

CARE and MAINTENANCE

cleaners cause darkening and discoloration. Test the cleaner on a small part of the rack and check for any discoloration before cleaning the entire rack. Apply a generous coating. Allow to stand for 15 to 20 minutes. Rinse thoroughly and dry. After being cleaned, if the racks do not slide easily, pour a small amount of cooking oil on a paper towel and rub it lightly over the side rails.

FRAME, SIDES, DOOR EXTERIOR, HEAT DEFLECTOR

These parts are made of stainless steel, follow the directions for the Back Panel and Shelf. Take care when cleaning the door top, and do not let water or cleaners run down the vents. If water or cleaners spill into the vents, they may streak the glass inside the door.

DOOR GASKET

Use a general kitchen spray cleaner, such as Formula 409® or Fantastik®. Spray it on and blot dry with a cloth. Do not rub. Do not remove or damage the mesh.

OVEN LIGHT BULB REPLACEMENT

For oven light bulb replacement use only a 40 watt, 120 volt appliance light bulb. These are available in supermarkets. **DO NOT** use a standard light bulb in any oven, the heat will break it.

To Replace the Light Bulb

1. Be sure the oven light bulb switch is in the off position. The bottom of the switch is pressed in. **Let the cover and the bulb cool completely.**
2. Remove the light cover. Turn the cover to the left (counterclockwise) to unscrew it.
3. Remove the burnt out bulb. Replace it with a 40 watt appliance light bulb only.
4. Replace cover. Turn circuit breaker back on, if turned off. (See Caution).

CAUTION: Be sure the Oven light switch is in the OFF position and the cover is cool. If the bulb comes loose from the base, turn off the power to the oven at the circuit breaker panel, before attempting to remove the bulb base from the socket.

POWER FAILURE

The broiler, oven, grill or griddle burners cannot be turned on during a power failure. To light the open top burners, turn the control knob to "LITE", hold a lighted match to the port ring. After the flame is burning all the way around the burner, adjust the flame. It is necessary to light each

burner separately, each time you want to use it.

LEVELING THE GRATES

Each individual burner grate comes equipped with (3) three leveling screws which can be adjusted for grate alignment. Alignment may be necessary to compensate for the appliances being out of level.

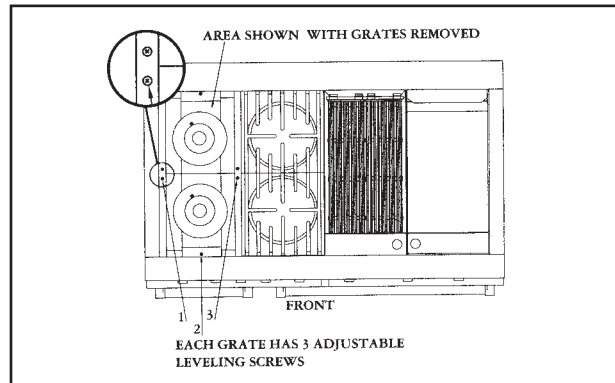

BEFORE YOU CALL FOR SERVICE

- Is the circuit breaker tripped or the fuse blown?
- Is there a power outage in the area?

IF THE COOKTOP BURNERS DO NOT LIGHT

- Is the two piece burner put together correctly?
- Is the port ring aligned correctly?
- Is the manual shut-off valve open? This is usually located where the gas comes out of the wall.

SERVICE INFORMATION

Copy the information below from the data rating plate. Keep your invoice for warranty validation.

Model Number

Serial Number

Date of Purchase

WARRANTY

***TO ENSURE WARRANTY SERVICE, FILL OUT AND SEND IN YOUR POSTAGE-PAID WARRANTY CARD**

This warranty covers the following and ranges. DCS RD 484 GG, DCS RD 486 GL, DCS RD 486 GD, DCS RD 364 GD, DCS RD 366, DCS RD 364 GL, DCS RD 304.

LENGTH OF WARRANTY

One (1) Year Full – Covers the entire product

Five (5) Years Limited – Surface burners, Griddle burners, Grill burner, Oven burner

Ten (10) Years Limited – Porcelain oven, Porcelain inner door panel

DCS WILL COVER:

All repair labor and replacement parts, for parts found to be defective due to materials or workmanship. Service must be provided by **Authorized Factory Agent** during normal working hours.

DCS WILL NOT COVER:

Installation or start-up

Normal adjustment to burners, gas regulators, etc.

Cleaning of igniters and/or general maintenance

Shipping damage

Service by an unauthorized agency. Damage or repairs due to service by an unauthorized agency or the use of unauthorized parts.

Overtime, weekends, holidays

Discoloration of the griddle plate

Improper installation, such as: **no regulator, improper hook-up, etc.**

Chipping of porcelain enamel grates

Service visits to:

- Correct the installation. (You are responsible for providing electrical wiring, gas installation and other connecting facilities.)
- Reset circuit breakers, replace home fuses, or establish gas supply.
- Damage caused from accident, abuse, alteration, misuse, incorrect installation or installation not in accordance with local codes.
- Repairs due to other than normal household use.
- Units installed in non-residential applications such as: **day care centers, bed and breakfast centers, churches, nursing homes, restaurants, hotels, schools, etc.**
- Supply the user with operational assistance covered in this manual.

This warranty applies to appliances used in residential applications; it does not cover their use in commercial situations.

This warranty is for products purchased and retained in the 50 states of the U.S.A., the District of Columbia and Canada. This warranty applies even if you should move during the warranty period. Should the appliance be sold by the original purchaser

during the warranty period, the new owner continues to be protected until the expiration date of the original purchaser's warranty period.

This warranty gives you specific legal rights. You may also have other rights which vary from state to state.

HOW TO OBTAIN SERVICE

For warranty service, contact your local DCS authorized service agency. Provide him with the **Model #, Serial #, gas type and date of installation, and a brief description of the problem.** If you need assistance in locating the authorized service agency in your area, contact your local dealer. He will have a listing of authorized DCS service agents in your area.

We want you to remain a satisfied customer. If a problem does come up that cannot be resolved to your satisfaction, please let us know. Write: **DCS, Customer Service Department, 5800 Skylab Road, Huntington Beach, CA 92467. Or call Customer Service/Parts (888) 281-5698 or fax us at (714) 372-7004.**

**Litho in USA 02-02
Part No. 10605 REV 3.**

**5800 Skylab Road, Huntington Beach, CA 92647
(714) 372-7000 Fax (714) 372-7001
Direct Parts/Customer Service (888) 281-5698**

As product improvement is an ongoing process at DCS, we reserve the right to change specifications or design without notice.



PERFECT HEAT.