

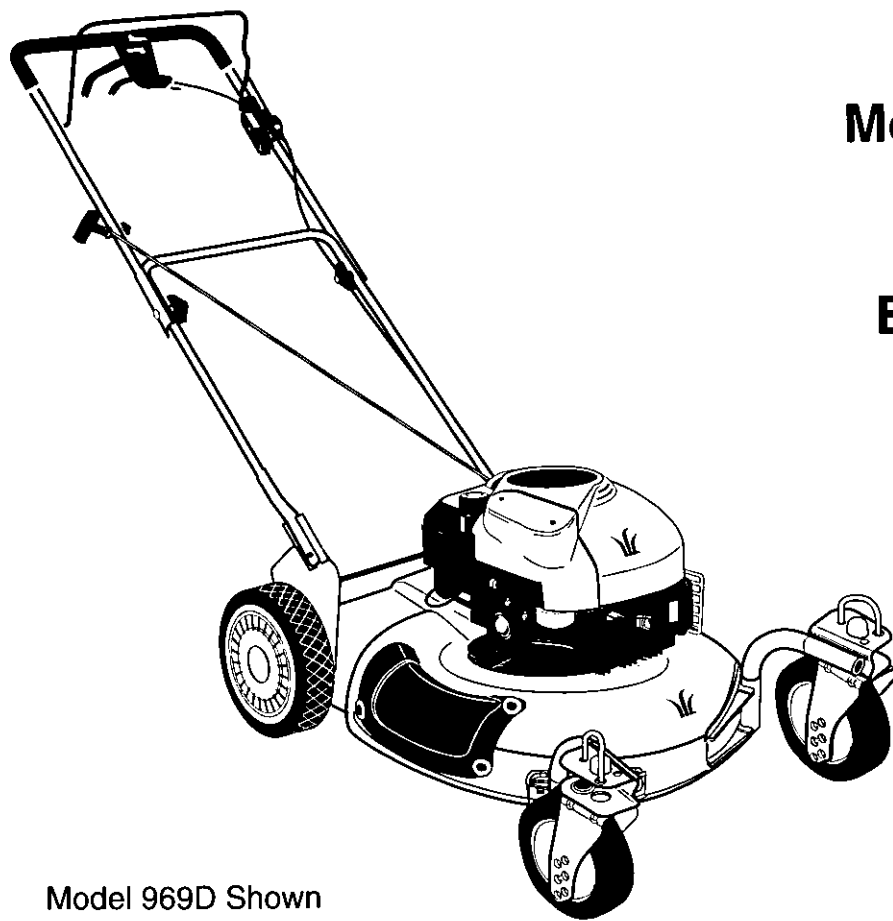

# OWNER'S GUIDE



Model 969D Shown

**Model Series**  
**950 - 959**  
**960-969**  
**E960-E969**



## **IMPORTANT: READ SAFETY RULES AND INSTRUCTIONS CAREFULLY**

**Warning:** This unit is equipped with an internal combustion engine and should not be used on or near any unimproved forest-covered, brush-covered or grass-covered land unless the engine's exhaust system is equipped with a spark arrester meeting applicable local or state laws (if any). If a spark arrester is used, it should be maintained in effective working order by the operator. In the State of California the above is required by law (Section 4442 of the California Public Resources Code). Other states may have similar laws. Federal laws apply on federal lands. A spark arrester for the muffler is available through your nearest engine authorized service dealer or contact the service department, P.O. Box 368022 Cleveland, Ohio 44136-9722.

**MTD PRODUCTS INC. P.O. BOX 368022 CLEVELAND, OHIO 44136-9722**

# SECTION 1: SLOPE GAUGE

USE THIS PAGE AS A GUIDE TO DETERMINE SLOPES WHERE YOU MAY NOT OPERATE SAFELY.

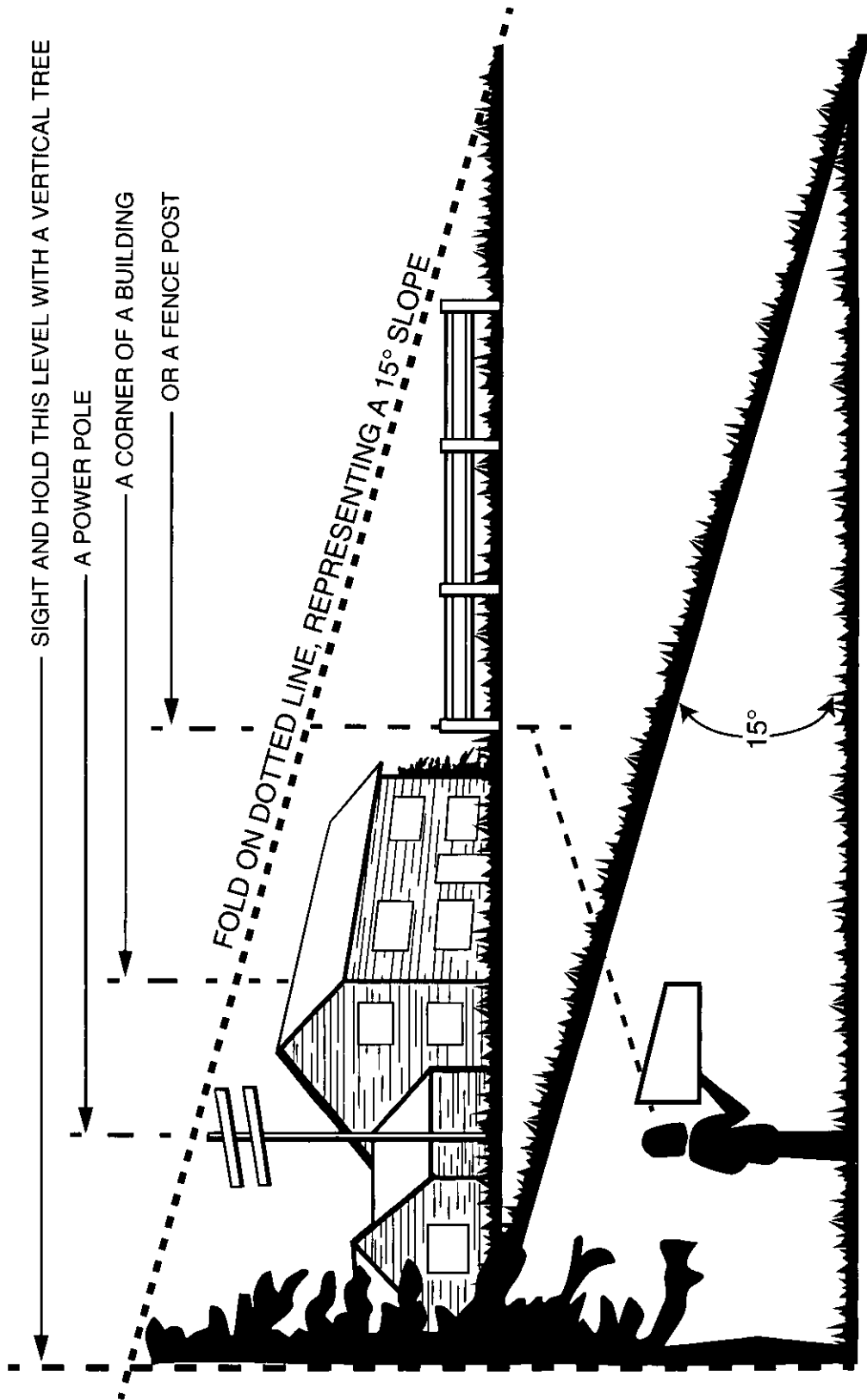

Do not mow on inclines with a slope in excess of 15 degrees (a rise of approximately 2-1/2 feet every 10 feet). A riding mower could overturn and cause serious injury. If operating a walk-behind mower on such a slope, it is extremely difficult to maintain your footing and you could slip, resulting in serious injury.

Operate RIDING mowers up and down slopes, never across the face of slopes.

Operate WALK-BEHIND mowers across the face of slopes, never up and down slopes.

## SECTION 2: IMPORTANT SAFE OPERATION PRACTICES



**WARNING:** THIS SYMBOL POINTS OUT IMPORTANT SAFETY INSTRUCTIONS WHICH, IF NOT FOLLOWED, COULD ENDANGER THE PERSONAL SAFETY AND/OR PROPERTY OF YOURSELF AND OTHERS. READ AND FOLLOW ALL INSTRUCTIONS IN THIS MANUAL BEFORE ATTEMPTING TO OPERATE YOUR LAWN MOWER. FAILURE TO COMPLY WITH THESE INSTRUCTIONS MAY RESULT IN PERSONAL INJURY. WHEN YOU SEE THIS SYMBOL, HEED ITS WARNING.



**DANGER:** Your lawn mower was built to be operated according to the rules for safe operation in this manual. As with any type of power equipment, carelessness or error on the part of the operator can result in serious injury. This lawn mower is capable of amputating hands and feet and throwing objects. Failure to observe the following safety instructions could result in serious injury or death.

### 1. GENERAL OPERATION

- Read this owner's guide carefully in its entirety before attempting to assemble this machine. Read, understand, and follow all instructions on the machine and in the manual(s) before operation. Be completely familiar with the controls and the proper use of this machine before operating it. Keep this manual in a safe place for future and regular reference and for ordering replacement parts.
- Your rotary mower is a precision piece of power equipment, not a plaything. Therefore, exercise extreme caution at all times. Your unit has been designed to perform one job: to mow grass. Do not use it for any other purpose.
- Never allow children under 14 years old to operate a power mower. Children 14 years old and over should only operate mower under close parental supervision. Only responsible individuals who are familiar with these rules of safe operation should be allowed to use your mower.
- Keep the area of operation clear of all persons, particularly small children and pets. Stop engine when they are in the vicinity of your mower to help prevent blade contact or thrown object injury. Although the area of operation should be completely cleared of foreign objects, an object may have been overlooked and could be accidentally thrown by the mower in any direction and cause serious personal injury to the operator or any others allowed in the area.
- Thoroughly inspect the area where the equipment is to be used. Remove all stones, sticks, wire, bones, toys and other foreign objects which could be picked up and thrown by the mower in any direction and cause serious personal injury to the operator or any others allowed in the area. Plan your mowing pattern to avoid discharge of material toward roads, sidewalks, bystanders and the like. To help avoid a thrown objects injury, keep children, bystanders and helpers at least 75 feet from the mower while it is in operation.
- Always wear safety glasses or safety goggles during operation or while performing an adjustment or repair, to protect eyes from foreign objects that may be thrown from the machine in any direction.
- Wear sturdy, rough-soled work shoes and close-fitting slacks and shirts. Shirts and pants that cover the arms and legs and steel-toed shoes are recommended. Do not wear loose fitting clothes or jewelry. They can be caught in moving parts. Never operate a unit in bare feet, sandals, slippery or light weight (e.g. canvas) shoes.
- Do not put hands or feet near or under rotating parts. Keep clear of discharge opening at all times as the rotating blade can cause injury.
- Many injuries occur as a result of the mower being pulled over the foot during a fall. Do not hang on to the mower if you are falling; release the handle immediately.
- Never pull the mower toward you while you are walking. If you must back the mower away from a wall or obstruction first look down and behind, and then follow these steps:
  - Step back from the mower to fully extend your arms.
  - Be sure you are well balanced with sure footing.
  - Pull the mower back slowly, no more than half way toward you.
  - Repeat these steps as needed.
- Do not operate the mower while under the influence of alcohol or drugs.
- Do not engage the self-propelled mechanism on units so equipped while starting engine.
- The blade control handle is a safety device. Never attempt to bypass its operation. Doing so makes the safety device inoperative and may result in personal injury through contact with the rotating blade. The blade control handle must operate easily in both directions and automatically return to the disengaged position when released.

- Never operate the mower in wet grass. Always be sure of your footing. A slip and fall can cause serious personal injury. Keep a firm hold on the handle and walk, never run. If you feel you are losing your footing, RELEASE THE BLADE CONTROL HANDLE IMMEDIATELY and the blade will stop rotating within three seconds.
- Mow only in daylight or good artificial light.
- Stop the blade when crossing gravel drives, walks or roads.
- If the equipment should start to vibrate abnormally, stop the engine and check immediately for the cause. Vibration is generally a warning of trouble.
- Shut the engine off and wait until the blade comes to a complete stop before removing the grass catcher or unclogging the chute. The cutting blade continues to rotate for a few seconds after the engine is shut off. Never place any part of the body in the blade area until you are sure the blade has stopped rotating.
- Never operate mower without proper guards, grass catcher, plates or other safety protective devices in place.
- Muffler and engine become hot and can cause a burn. Do not touch.
- Only use accessories approved for this machine by the manufacturer. Read, understand, and follow all instructions provided with the approved accessory.
- If situations occur which are not covered in this manual, use care and good judgment. Contact your dealer for assistance.

## 2. SLOPE OPERATION

For your safety, use the slope gauge included as part of this manual to measure slopes before operating this unit on a sloped or hilly area. If the slope is greater than 15 degrees as shown on the slope gauge, do not operate this unit on that area or serious injury could result.

### DO:

- Mow across the face of slopes; never up and down. Exercise extreme caution when changing direction on slopes.
- Watch for holes, ruts, hidden objects, or bumps. Tall grass can hide obstacles.
- Always be sure of your footing. A slip and fall can cause serious personal injury. If you feel you are losing your balance release the blade control handle immediately and the blade will stop in less than 3 seconds.
- ON MODELS WITH CASTER WHEELS: Lock both front wheels so they do not pivot while mowing on the face of slopes. To turn the mower, depress the handle and raise the front wheels slightly.

### DO NOT:

- Do not mow near drop-offs, ditches or embankments. The operator could lose footing or balance.
- Do not mow slopes greater than 15 degrees as shown on the slope gauge.
- Do not mow on wet grass. Reduced footing could cause slipping.
- ON MOWERS WITH CASTER WHEELS: Mow on slopes with casters unlocked since the mower has a tendency to drift down hill.

## 3. CHILDREN

Tragic accidents can occur if the operator is not alert to the presence of children. Children are often attracted to the mower and the mowing activity. Never assume that children will remain where you last saw them.

- Keep children out of the mowing area and under the watchful care of a responsible adult other than the operator.
- Be alert and turn mower off if a child enters the area.
- Before and while moving backwards, look behind and down for small children or other objects.
- Never allow children under age 14 to operate the mower. Children 14 years of age and above should read and understand the operation instructions and safety rules in this manual.
- Use extreme care when approaching blind corners, shrubs, trees, or other objects that may obscure your vision of a child or hazard.

## 4. SERVICE

- Use extreme care in handling gasoline and other fuels. They are extremely flammable and the vapors are explosive.
- Use only an approved gasoline container.
- Never remove gas cap or add fuel while the engine is running. Allow engine to cool at least two minutes before refueling.
- Replace gasoline cap securely and wipe off any spilled gasoline before starting the engine as it may cause a fire or explosion.
- Extinguish all cigarettes, cigars, pipes and other sources of ignition.
- Never refuel machine indoors because flammable vapors will accumulate in the area.
- Never store the machine or fuel container inside where there is an open flame or spark such as a gas water heater, space heater, or furnace.
- Never run an engine inside a closed area.
- To reduce fire hazard, keep mower free of grass, leaves, or other debris build-up. Clean up oil or fuel spillage. Allow mower to cool at least 5 minutes before storing.
- Before cleaning, repairing, or inspecting, make certain the blade and all moving parts have stopped.

Disconnect the spark plug wire, and keep the wire away from the spark plug to prevent accidental starting.

- Check the blade and engine mounting bolts at frequent intervals for proper tightness. Also, visually inspect blade for damage (e.g., bent, cracked or worn). Replace with blade which meets original equipment specifications listed in this manual.
- Keep all nuts, bolts, and screws tight to be sure the equipment is in safe working condition.
- Never tamper with safety devices. Check their proper operation regularly.
- After striking a foreign object, stop the engine, remove the wire from the spark plug, and thoroughly inspect the mower for any damage. Repair the damage before starting and operating the mower.

- Never attempt to make a wheel or cutting height adjustment while the engine is running.
- Grass catcher components are subject to wear, damage and deterioration, which could expose moving parts or allow objects to be thrown. For safety protection, frequently check components and replace with manufacturer's recommended parts, when necessary.
- Mower blades are sharp and can cut. Wrap the blade(s) or wear gloves, and use extra caution when servicing them.
- Do not change the engine governor setting or overspeed the engine. Excessive engine speeds are dangerous.



**WARNING - YOUR RESPONSIBILITY:** Restrict the use of this power machine to persons who read, understand and follow the warnings and instructions in this manual and on the machine.



Figure 1: Safety Labels Found On Lawn Mower

### SECTION 3: FINDING YOUR MODEL NUMBER

This Owner's Guide is an important part of your new lawn mower. It will help you assemble, prepare and maintain your mower. Please read and understand what it says.

Before you start to prepare your mower for its first use, please locate the model plate and copy the information from it in this Owner's Guide. The information on the model plate is very important if you need help from your dealer or the MTD customer support department.

- Every mower has a model plate. You can locate it by standing behind the unit in the operating position and looking down at the cutting deck.

- The model plate will look like Figure 2.

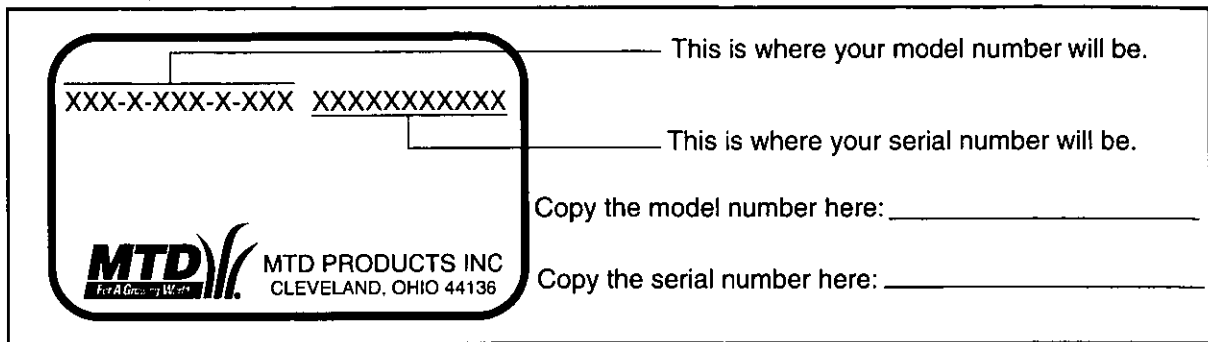

Figure 2

## SECTION 4: UNPACKING INSTRUCTIONS

### REMOVE UNIT FROM CARTON

- See Figure 3.
- Remove staples, break glue on top flaps, or cut tape at carton end and peel along top flap to open carton.
- Remove loose parts if included with unit (i.e., owner's manual, etc.).
- Cut along dotted lines and lay carton down flat.
- Remove packing material.
- Roll or slide unit out of carton. Check carton thoroughly for loose parts.

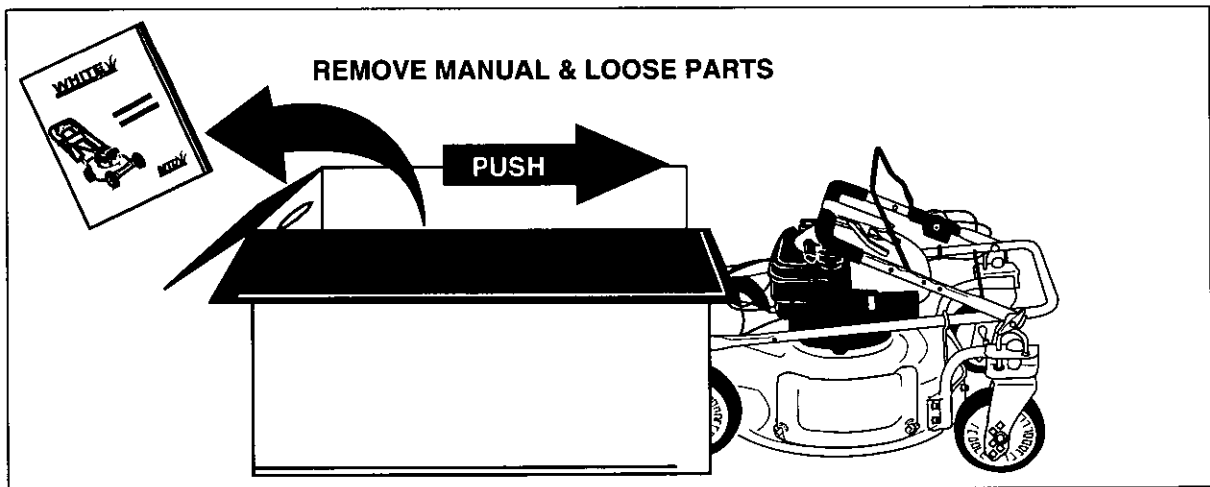

Figure 3

### DISCONNECT SPARK PLUG WIRE

Before setting up your lawn mower, disconnect the spark plug wire from the spark plug, and ground it against the

engine by attaching rubber boot to a bolt or metal clip to the grounding post on the engine. See Figure 4.

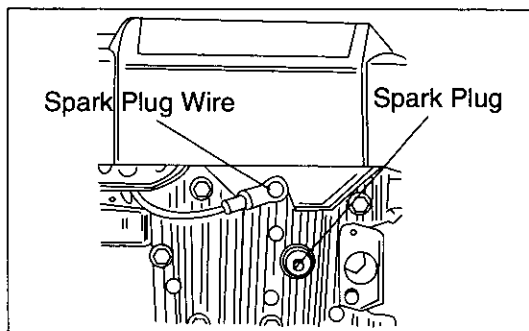

Figure 4

## SECTION 5: SET-UP INSTRUCTIONS

This guide covers two model series. 950 - 959 have fixed front wheels. 960 - 969 have caster front wheels. All models are six speed, self propelled mowers. Much of this guide pertains to both models. However, there are some areas where only one model is covered. Use only the information that is appropriate for your model.

### ITEMS REQUIRED FOR ASSEMBLY

- Pair of Pliers (Not necessary, but helpful)
- Motor Oil
- Fresh Gasoline

**IMPORTANT:** This unit is shipped WITHOUT GASOLINE in the fuel tank or OIL in the engine. Be certain to service engine with gasoline and oil as instructed in the separate engine manual before operating your mower.

**NOTE:** Reference to right or left hand side of the mower is observed from the operating position.

### SET-UP YOUR LAWN MOWER

Follow steps 1 through 10 to set up your lawn mower.

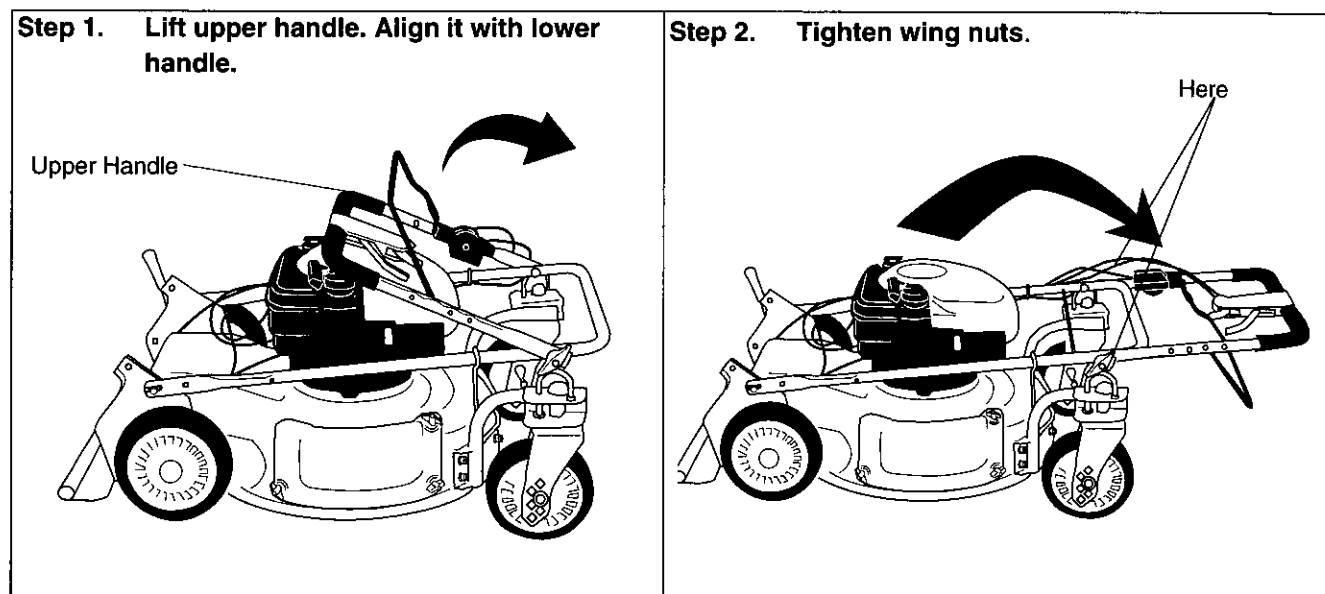

**Step 3.** Raise complete handle assembly until it clicks into place. Make sure not to kink the control cables.

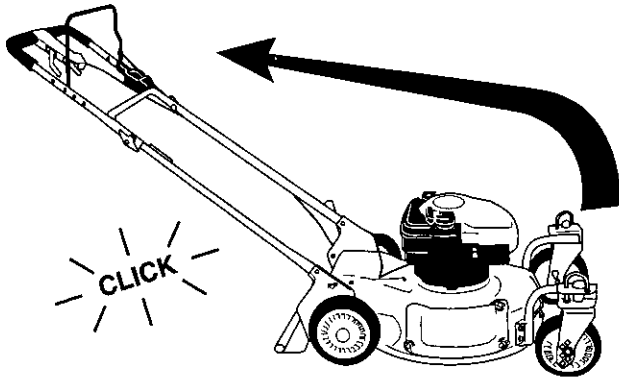

**Step 4.** Pinch lower handle against mounting bracket with pliers.

**Step 5.** Move hairpin clip from outer to inner hole on handle mounting bracket.

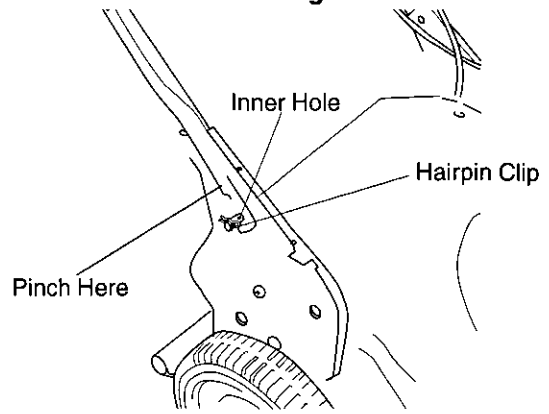

**Step 6.** Attach control cables to handle with pull ties found on the handle.

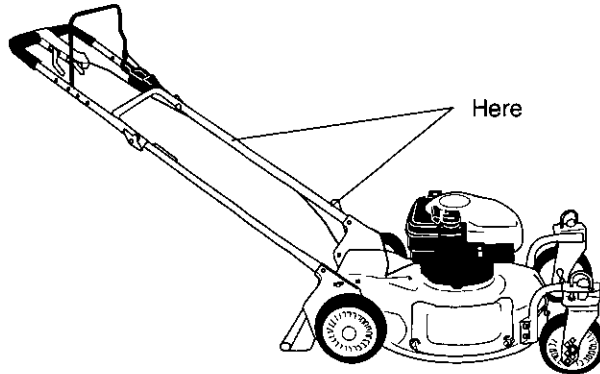

**Step 7.** Loosen the wing nut holding the rope guide to the upper handle.

**Step 8.** Squeeze the blade control handle against the upper handle and pull out starter rope, slowly!

**Step 9.** Thread starter rope into rope guide.

**Step 10.** Tighten wing nut.

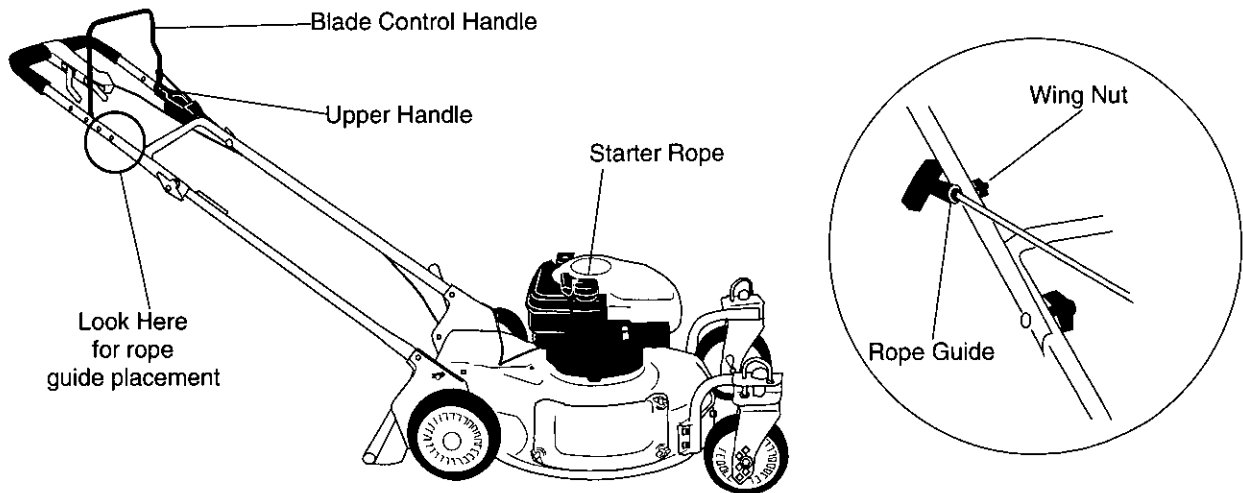

- Your mower has been shipped in the lowest possible cutting position for shipping purposes. Please see the "cutting height adjustment lever" section on page 10 of this owner's guide to adjust cutting height.



## SECTION 6: CONTROLS

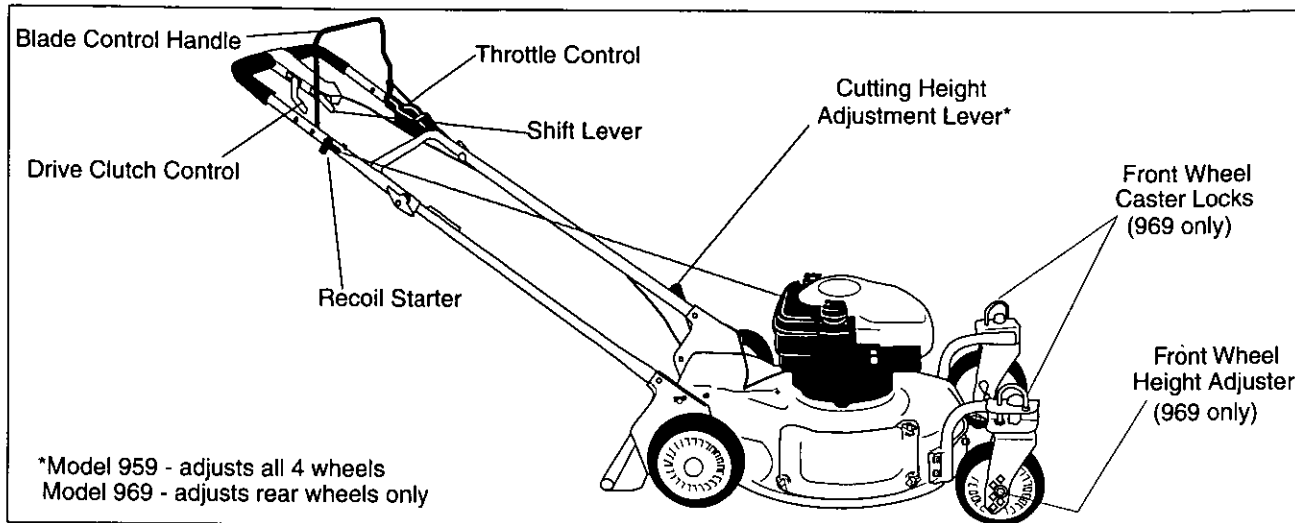

Figure 5

### BLADE CONTROL HANDLE

The blade control handle is located on the upper handle of the mower. See Figure 5. The blade control handle must be depressed in order to start and operate the unit. Release the blade control handle to stop the engine and blade.



**WARNING:** The blade control handle is a safety device. Never attempt to bypass its operations. The blade will be rotating whenever the engine is running.

### THROTTLE CONTROL

The throttle control is located on the left side of the upper handle. It is used to regulate the engine speed. See Figure 5

- Push the throttle lever forward for fast.
- Pull the throttle lever back for slow.



**WARNING:** The throttle control cannot be used to stop the engine.

### IGNITION SWITCH (Electric Start Unit Only)

The ignition switch is located on the left side of the handle panel. It is used for starting only. See Figure 6

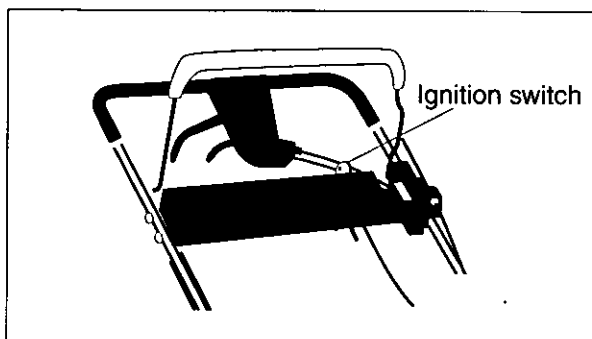

Figure 6 Electric Start Unit Only

## RECOIL STARTER

The recoil starter handle is attached to the upper handle. See Figure 5. Stand behind the unit in the operating position to start the unit.

## DRIVE CLUTCH CONTROL

Squeezing the drive clutch control engages the drive system. Releasing the clutch control disengages the drive system. Release the clutch control to slow down when negotiating an obstacle, making a turn or stopping.

## SHIFT LEVER

The shift lever is located on the drive clutch control housing on the upper handle. See Figure 5. This lever is used to select the forward speed of the mower. When changing your speed selection, release the drive clutch control.

**NOTE:** Only move the shift lever when the engine is running. Changing the shift lever setting with the engine off can cause damage to the mower.

## CUTTING HEIGHT ADJUSTMENT LEVER (Model 950-959)

The cutting height adjustment lever is located above the left rear wheel. To adjust the cutting height, pull the lever out and away from the mower. Then move it forward or back to the desired cutting height. See Figure 5

## CUTTING HEIGHT ADJUSTMENT LEVER (Model 960-969)

The **rear wheel** cutting height adjustment lever is located above the left rear wheel. To adjust the cutting height, pull the lever out and away from the mower. Move it forward or back to the desired cutting height. See Figure 5

The **front wheel** cutting height is determined by the selection of one of six positions in each caster assembly.

To adjust, remove the wing nut from the axle bolt. Slide the axle bolt and spring washer from the assembly and select a cutting height. With the spring washer on the axle bolt reinsert in the square hole desired, through the wheel assembly and secure with the wing nut previously removed. Remember, the higher the position, the lower the cut.

**IMPORTANT:** All wheels must be placed in the same relative position. For rough or uneven lawns, raise the cutting height of your mower.

**NOTE:** For rough or uneven lawns, move the height adjustment lever to a higher position. This will help stop scalping.

## CASTER LOCK



**Warning:** When operating mower on hills, front wheels should be locked in the straight ahead position.

The casters can be locked in a straight ahead position or can be left to swivel freely. Lift and place the lock pins in the larger holes for locked, straight ahead operation, place pins in smaller holes to allow casters to rotate freely.

## ENGINE CONTROLS

See the engine manual for the location and function of the controls located on the engine.

---

## SECTION 7: OPERATION



**WARNING:** Keep hands and feet away from the chute area on cutting deck. See Figure 1:. The operation of any lawn mower can result in foreign objects being thrown into the eyes, which can result in severe eye damage. Always wear safety glasses or eye shields.

**NOTE:** For best results raise the cutting position until it is determined which height is best for your lawn. See CUTTING HEIGHT ADJUSTMENT LEVER in the CONTROLS section.

## GAS AND OIL FILL-UP

Service the engine with gasoline and oil as instructed in the separate engine manual. Read all instructions carefully.



**WARNING:** Never fill fuel tank indoors, with engine running or until the engine has been allowed to cool for at least two minutes after running.

## EACH TIME BEFORE YOU START YOUR MOWER ELECTRIC START UNITS ONLY:



**Warning:** The battery contains corrosive fluid and toxic material-HANDLE WITH CARE. Keep away from children. Do not puncture disassemble, mutilate or incinerate. Explosive gasses could be vented during charging or discharging. Use in a well ventilated area, away from sources of ignition.

## Charging Instructions

Charge battery for 16 hours before initial use. **DO NOT CHARGE LONGER THAN 20 HOURS.**

**IMPORTANT:** Use only the battery charger supplied with this mower.

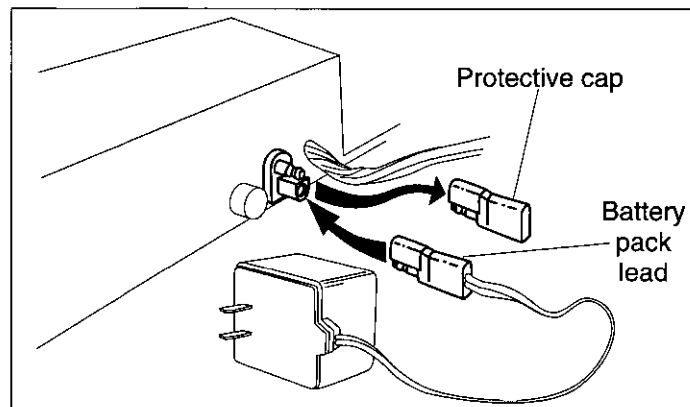

Figure 7

To charge the battery, first remove the protective cap from the end of the battery pack lead. Always plug charger lead into battery pack lead before inserting battery charger plug into 120 volt standard household outlet. See Figure 7

After charging, disconnect battery charger plug from household outlet first, than disconnect charger lead from battery pack lead.



**Warning:** Do not remove the battery pack from the handle panel for any reason other than replacement. When replacing the battery pack, refer to the instructions in the maintenance section.

## All Units:

- Attach spark plug wire to spark plug. Make certain the metal cap on the end of the spark plug wire is fastened securely over the metal tip on the spark plug.
- Check for proper drive clutch operation using the NEUTRAL ADJUSTMENT TEST.

## NEUTRAL ADJUSTMENT TEST

To perform the NEUTRAL ADJUSTMENT TEST answer the following questions.

- With the drive clutch control released, push mower forward and pull it backward. Does it move freely?
- Squeeze the drive clutch control and pull the mower backward. Do the rear wheels lock (not turn)?
- Is the drive clutch control cable free of kinks or sharp bends?

If you answered “**yes**” to all three questions, your mower passed the test and you can start your mower. If you answered “**no**” to any of the three questions, you need to go through the DRIVE CLUTCH CONTROL ADJUSTMENT found in the ADJUSTMENTS section.

## TO START ENGINE AND ENGAGE BLADE

- Move the throttle control lever all the way forward.
- Prime or choke engine as instructed in the separate engine manual.
- Stand behind the unit, squeeze and hold the blade control handle against the upper handle.
- **Electric Start unit:** Turn the ignition key to the right to start the engine. Release the key after the engine starts.
- **Recoil Start:** Grasp starter handle and pull rope out slowly until engine reaches start of compression cycle (rope will pull slightly harder at this point). Let the rope rewind slowly. Pull rope with a rapid, continuous, full arm stroke. Keep a firm grip on starter handle. Return it slowly to the rope guide.
- After engine starts, move throttle control to desired engine speed. (The mower is designed to be operated at full throttle.)

**NOTE:** If any problems are encountered, refer to the TROUBLE SHOOTING Section of this manual.

## TO STOP ENGINE AND BLADE

- Release the blade control handle to stop the engine and blade.



**WARNING:** The blade continues to rotate for a few seconds after the engine is shut off.

## USING YOUR ROTARY MOWER

Be sure that lawn is clear of stones, sticks, wire, or other objects which could damage the lawn mower or engine. Such objects could be accidentally thrown by the mower in any direction and cause serious personal injury to the operator and others.

For the best results, do not cut wet grass because it tends to stick to the underside of the mower, preventing proper discharge of grass clippings, and could cause you to slip and fall. New grass, thick grass or wet grass may require a narrower cut.

For a healthier lawn, never cut off more than one-third of the total length of the grass. Your lawn should be cut in the fall as long as there is growth.

This mower is designed to be operated at full throttle to give you the best cut and do the most effective job of mowing or mulching.



**WARNING:** If you strike a foreign object, stop the engine. Remove wire from spark plug, thoroughly inspect the mower for any damage, and repair the damage before restarting and operating the mower. Extensive vibration of the mower during operation is an indication of damage. The unit should be promptly inspected and repaired.

## SIDE DISCHARGE GRASS CLIPPINGS

This mower can side discharge grass clippings. Follow steps 1 and 2 to ready this mower for side discharge operation

**Step 1.** Remove three plastic wing nuts and mulching cover.

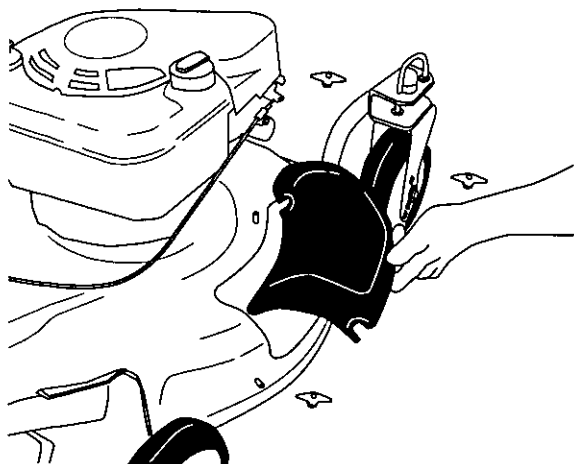

**Step 2.** Replace with side discharge chute and three plastic wing nuts.

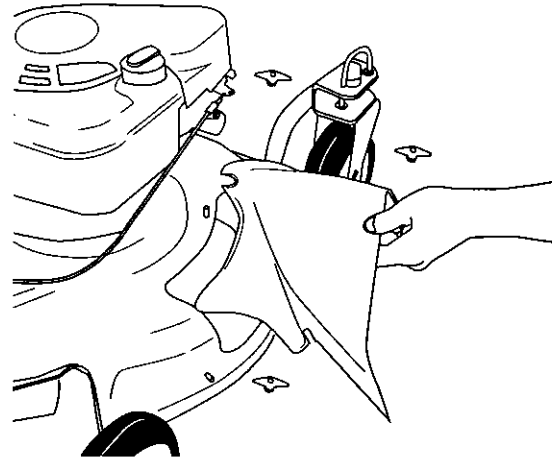

## SECTION 8: ADJUSTMENTS



**WARNING:** Do not at any time make any adjustment to lawn mower without first stopping engine and disconnecting spark plug wire.

### HANDLE HEIGHT ADJUSTMENT

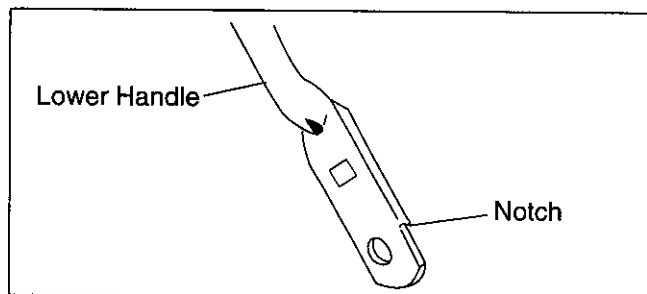

Figure 8

Your mower is shipped with the handle in the higher height position. To lower the handle height, proceed as follows.

- Remove the starter rope from the rope guide.
- Remove the upper handle by removing the hand knobs and carriage bolts. Lay the upper handle out of the way, being careful not to bend or kink the cables.
- Remove the hairpin clips from the weld pins on the handle brackets. Press out on the legs of the lower handle. Remove lower handle from the mower.
- Turn the lower handle around so the notch on the bottom of the lower handle is facing forward as shown in Figure 8. Reassemble, placing the bottom holes in the handle over the weld pins in the handle mounting bracket.
- Reassemble the upper handle to the lower handle.
- Place the hairpin clips in the inner holes in the weld pins and attach the starter rope as instructed in the Set-Up Instructions.

## THROTTLE CONTROL ADJUSTMENT

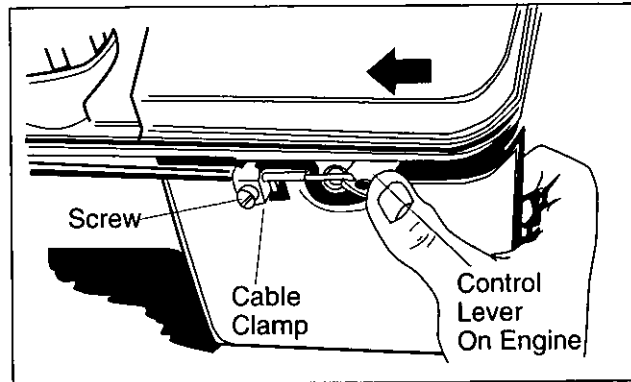

Figure 9

If the throttle control requires adjustment or if it has been replaced, adjust the throttle control as follows.

- Remove the screw shown in Figure 9. Remove the cable clamp from the cable.
- Push the throttle control lever on the handle all the way forward as far as it will go, then back it off one "click". Make certain the throttle control lever remains in this position.
- Push the control lever on the engine as far toward the rear of the engine as it will go. Secure the cable in this position with the cable clamp and screw.

## DRIVE CLUTCH CONTROL ADJUSTMENT

The drive clutch control adjustment wheel is located in the drive clutch control handle housing and is used to tighten or loosen the drive belt. You will have to adjust the drive clutch control if any of the following happens:

- The mower does not propel itself with the drive clutch engaged.
- The mower's drive wheels hesitate with the drive clutch engaged.

To resolve the above problems, rotate the adjustment wheel with your fingers. Clockwise to tighten the cable and counter-clockwise to loosen the cable. See Figure 10

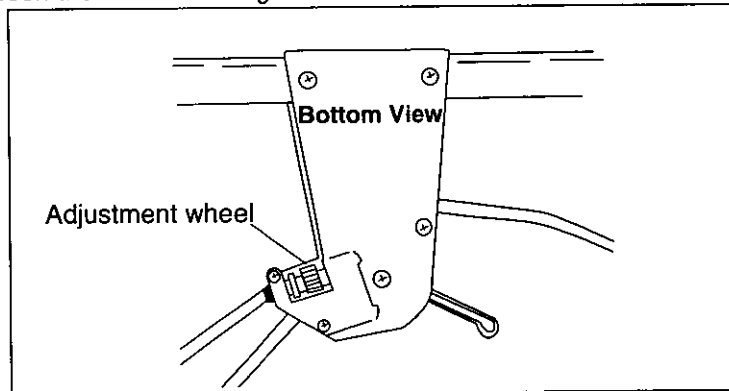

Figure 10

**Note:** For some people the drive clutch handle may not be in a comfortable position. You can adjust the handle out by tightening the adjustment wheel.

---

## SECTION 9: LUBRICATION



**WARNING:** Always stop engine and disconnect spark plug wire before cleaning, lubricating or doing any kind of work on the lawn mower.

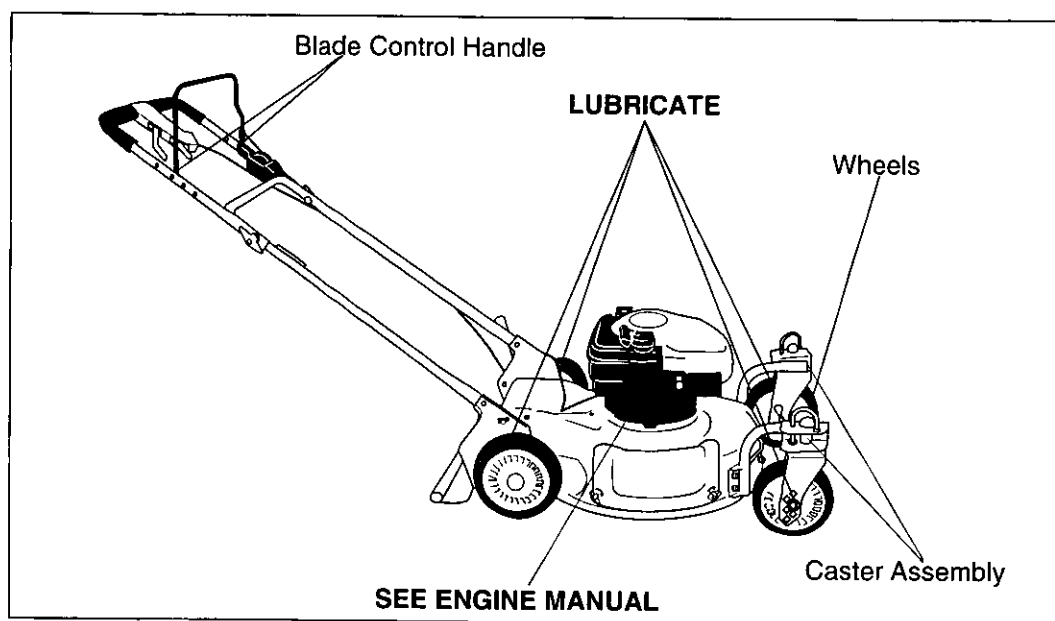

Figure 11

**Blade Control:** Lubricate the pivot points on the blade control handle and the brake cable at least once a season with light oil. See Figure 11. The blade control must operate freely in both directions.

**Wheels:** Lubricate the wheel at least once a season with light oil (or engine oil). Also, if the wheels are removed for any reason, lubricate the surface of the axle bolt and the inner surface of the wheel with light oil. See Figure 11.

**Caster Assembly (960-969 only):** Grease fittings are provided for easy lubrication of the swivel pins located on the front caster assembly.

**Engine:** Follow engine manual for lubrication instructions.

## SECTION 10: MAINTENANCE



**WARNING:** Be sure to disconnect and ground the spark plug wire before performing any repairs or maintenance.

**NOTE:** When tipping the unit, empty the fuel tank and keep engine, spark plug side up. Never tip the mower more than 90 degrees and do not leave the mower tipped for any length of time. Oil can drain into the upper part of the engine causing a starting problem.

### ENGINE

Refer to the separate engine manual for all engine maintenance instructions.

- Maintain engine oil as instructed in the separate engine manual packed with your unit. Read and follow instructions carefully.
- Service air cleaner every 25 hours under normal conditions. Clean every few hours under extremely dusty conditions. Poor engine performance and flooding usually indicates that the air cleaner should be serviced. To service the air cleaner, refer to the separate engine manual packed with your unit.

- The spark plug should be cleaned and the gap reset once a season. Spark plug replacement is recommended at the start of each mowing season; check engine manual for correct plug type and gap specifications.
- Clean the engine regularly with a cloth or brush. Keep the cooling system (blower housing area) clean to permit proper air circulation which is essential to engine performance and life. Be certain to remove all grass, dirt and combustible debris from muffler area.

## DECK

The underside of the mower deck should be cleaned after each use to prevent a buildup of grass clippings, leaves, dirt or other matter. If this debris is allowed to accumulate, it will invite rust and corrosion, and may prevent proper mulching, discharge or bagging.

The deck may be cleaned by tilting the mower and scraping clean with a suitable tool (make certain the spark plug wire is disconnected).

## ELECTRIC START UNITS ONLY:

### BATTERY PACK REPLACEMENT

Remove the battery pack from the handle panel for replacement only. Do not separate the batteries for any reason. Dispose of batteries properly.



**WARNING:** Batteries contain sulfuric acid which may cause burns. Do not short circuit or mutilate in any way. Do not put batteries in fire. They may burst or release toxic materials.

When replacing battery pack in handle panel, battery pack must be positioned with the positive terminal to the right hand side and the negative terminal to the left hand side of panel. Replacing the battery pack incorrectly will cause serious damage.

The positive lead on the wire harness has the smaller connector. Connect the positive lead to the positive side of the battery pack, then connect the negative side.

### IN-LINE FUSE

The unit is equipped with an in-line fuse. If unit fails to start, check the fuse inside the battery cover by turning the end of the fuse holder and removing from the battery cover. Replace with standard automotive 7-1/2 amp fuse.

## STORAGE OF THE BATTERY

The battery must be stored with a full charge. A discharged battery will freeze.

**IMPORTANT:** All batteries discharge during storage. Recharge battery every two months and before returning to service. Refer to charging instructions in Operation section.

## CUTTING BLADE REMOVAL, REPLACEMENT AND SHARPENING

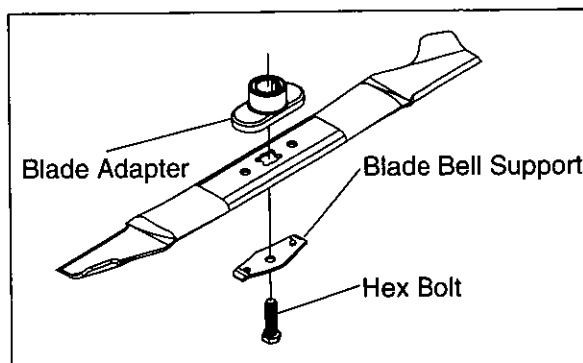

Figure 12



- When removing the cutting blade for sharpening or replacement, protect hands by using heavy gloves or a rag before grabbing the blade.
- Remove the bolt and blade bell support which hold the blade and adapter to the engine crankshaft.
- Remove the blade and adapter from the crankshaft.



**WARNING:** Periodically inspect the blade adapter for cracks, especially if you strike a foreign object. Replace when necessary.

When sharpening the blade, follow the original angle of grind as a guide. It is extremely important that each cutting edge receives an equal amount of grinding to prevent an unbalanced blade. An unbalanced blade will cause excessive vibration when rotating at high speeds. It may cause damage to the mower, and it could break causing personal injury.

The blade can be tested by balancing it on a round shaft screwdriver. Remove metal from the heavy side until it balances evenly. It is recommended that the blade always be removed from the adapter when testing for balance. Before reinstalling the blade and the blade adapter to the unit, lubricate the engine crankshaft and the inner surface of the blade adapter with light oil.

- Be sure to install the blade with the side of the blade marked "Bottom" (or with part number) facing the ground when the mower is in the operating position. See Figure 12
- Slide blade adapter onto engine crankshaft.
- Place blade on adapter. Be certain the blade is aligned with and seated onto the blade adapter flanges.
- Place blade bell support on blade. Make sure the notches on the blade bell support are aligned with the small hole in the blade.
- Replace hex bolt.
- Tighten hex bolt to torque: 450 in. lbs. min., 600 in. lbs. max.

**NOTE:** To ensure safe operation of your unit, the blade bolt must be checked periodically for correct torque.

## TROUBLE SHOOTING

Refer to the trouble shooting section of this manual for helpful information.

## SHIFT LEVER CABLE ADJUSTMENT

Periodic adjustment of the six speed shift cable may be required due to normal wear on the cable. Adjustment is needed if all six speeds do not work.

The adjustable cable bracket is located on the left side of the mower, beside the engine. Follow steps 1 through 7 to adjust the shift lever.

- Step 1. Start engine.**
- Step 2. Place speed control in the sixth speed position.**
- Step 3. Stop engine.**
- Step 4. Disconnect the spark plug wire and ground it.**

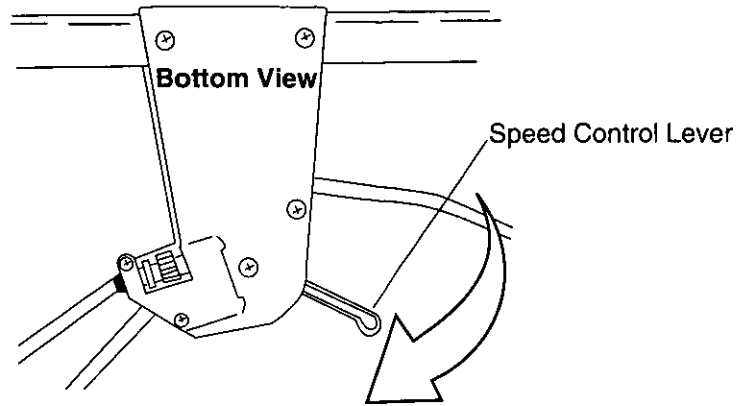

- Step 5. Loosen hex nut (A) which secures the adjustable cable bracket.**
- Step 6. Push back on the adjustable cable bracket.**
- Step 7. Tighten hex nut (A).**

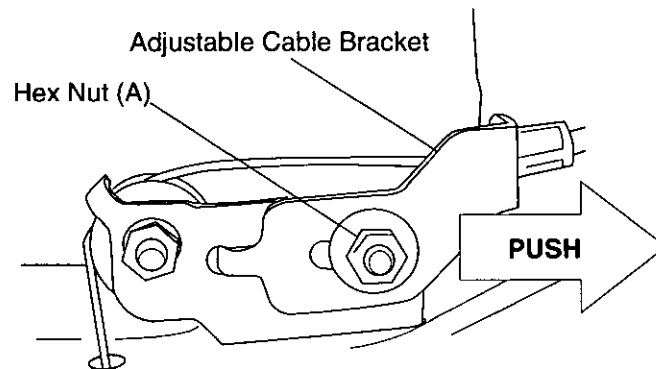

## DRIVE BELT REMOVAL AND REPLACEMENT

If you need to replace a worn or broken drive belt, follow steps 1 through 16.

- Step 1. Disconnect the spark plug and ground it.
- Step 2. Drain the fuel tank.
- Step 3. Remove rear hub caps and wheels.
- Step 4. Tip mower back on its handle and block securely.
- Step 5. Remove blade and blade adapter.
- Step 6. Remove three hex head and two phillips head screws holding the baffle in place.
- Step 7. Remove baffle.

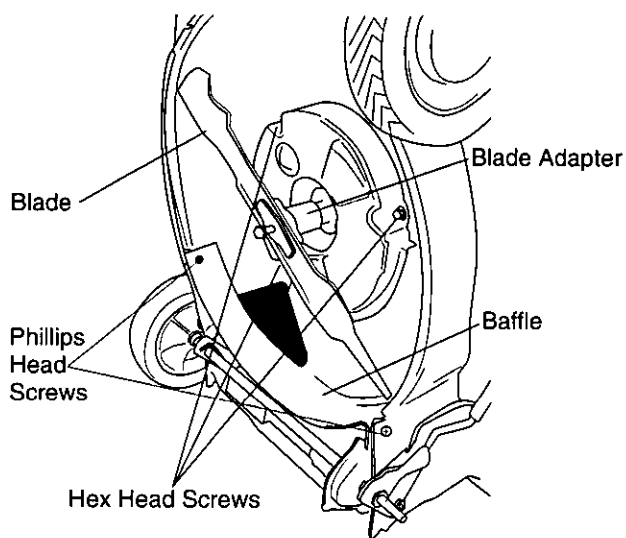

- Step 8. Loosen hex lock nut holding idler bearing.
- Step 9. Push back and rotate belt keeper.
- Step 10. Remove and replace belt.
- Step 11. Replace belt keeper to its original position. Tighten the hex lock nut.

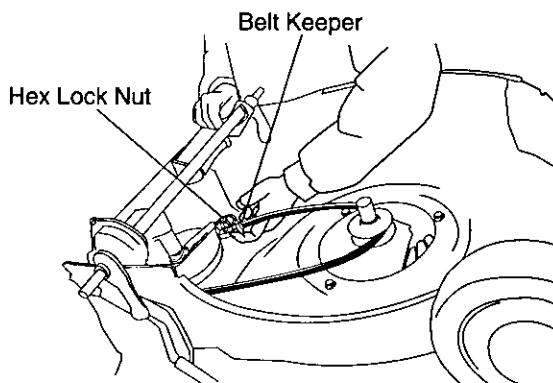

Mower shown tipped on engine for clarity. Remember, only tip mower back on its handle with the spark plug facing up.

**Step 12.** Replace baffle and secure with 3 hex head and 2 phillips screws.

**Step 13.** Replace blade adapter and blade. See the Blade Removal, Sharpening and Replacement Section for proper assembly.

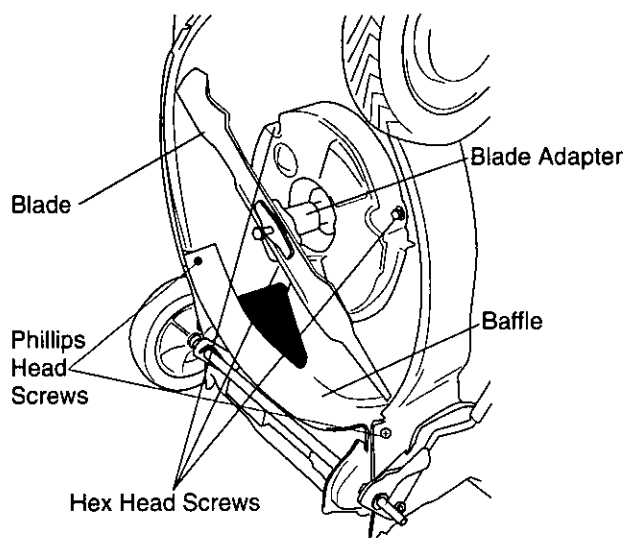

**Step 14.** Replace the rear wheels, rear wheel gears and hub caps. The gears need to be put on in the right way for the self propelled mechanism to work. Check the installation of the gear by spinning the wheel. It should spin freely in one direction but not the other. If the wheel spins freely in both directions, flip the gear over.

**Step 15.** Tip mower back onto its wheels

**Step 16.** Go through the neutral adjustment test in the operation section.

## SECTION 11: OFF-SEASON STORAGE

The following steps should be taken to prepare lawn mower for storage.

- Clean and lubricate mower thoroughly as described in the lubrication instructions.
- Refer to engine manual for correct engine storage instructions.
- Coat mower's cutting blade with chassis grease to prevent rusting.
- Follow battery storage instructions on page 16 (Electric Start Units Only).
- Store mower in a dry, clean area. Do not store next to corrosive materials, such as fertilizer.

**NOTE:** When storing any type of power equipment in an unventilated or metal storage shed, care should be taken to rust-proof the equipment. Using a light oil or silicone, coat the equipment, especially cables and all moving parts.

## SECTION 12: TROUBLE SHOOTING GUIDE

Trouble	Possible Cause(s)	Corrective Action
Engine fails to start	Blade control handle disengaged. Spark plug wire disconnected. Throttle control lever not in correct starting position. Fuel tank empty, or stale fuel. Blocked fuel line. Faulty spark plug. Engine flooded.	Engage blade control handle. Connect wire to spark plug. Move throttle lever to FAST or START position. Fill tank with clean, fresh gasoline. Clean fuel line. Clean, adjust gap or replace. Crank engine with throttle in FAST position.
Engine runs erratic	Unit running in START position. Spark plug wire loose. Blocked fuel line or stale fuel.  Vent in gas cap plugged. Water or dirt in fuel system. Dirty air cleaner. Carburetor out of adjustment.	Move throttle lever to FAST position. Connect and tighten spark plug wire. Clean fuel line; fill tank with clean, fresh gasoline. Clear vent. Drain fuel tank. Refill with fresh fuel. Clean air cleaner. Adjust carburetor.
Engine overheats	Engine oil level low. Air flow restricted. Carburetor not adjusted properly.	Fill crankcase with proper oil. Remove blower housing and clean. Adjust carburetor.
Occasional skip (hesitates) at high speed	Spark plug gap too close.	Adjust gap to .030".
Idles poorly	Spark plug fouled, faulty or gap too wide. Carburetor improperly adjusted. Dirty air cleaner.	Reset gap to .030" or replace spark plug. Adjust carburetor. Clean air cleaner.
Excessive vibration	Cutting blade loose or unbalanced. Bent cutting blade.	Tighten blade and adapter. Balance blade. Replace blade.
Mower will not mulch grass	Engine speed too low. Wet grass.  Excessively high grass.  Dull blade.	Set throttle between 3/4 and full throttle. Do not mow when grass is wet; wait until later to cut. Mow once at a high cutting height, then mow again at desired height or make a narrower cutting swath (1/2 width). Sharpen or replace blade.
Uneven cut	Wheels not positioned correctly.  Dull blade.	Place all four wheels in same height position. Sharpen or replace blade.

Refer to separate engine manual packed with your mower for more engine related information.

**NOTE:** For repairs beyond the minor adjustments listed above, contact your nearest authorized service dealer or call 1-800-94WHITE.

# MODEL 959

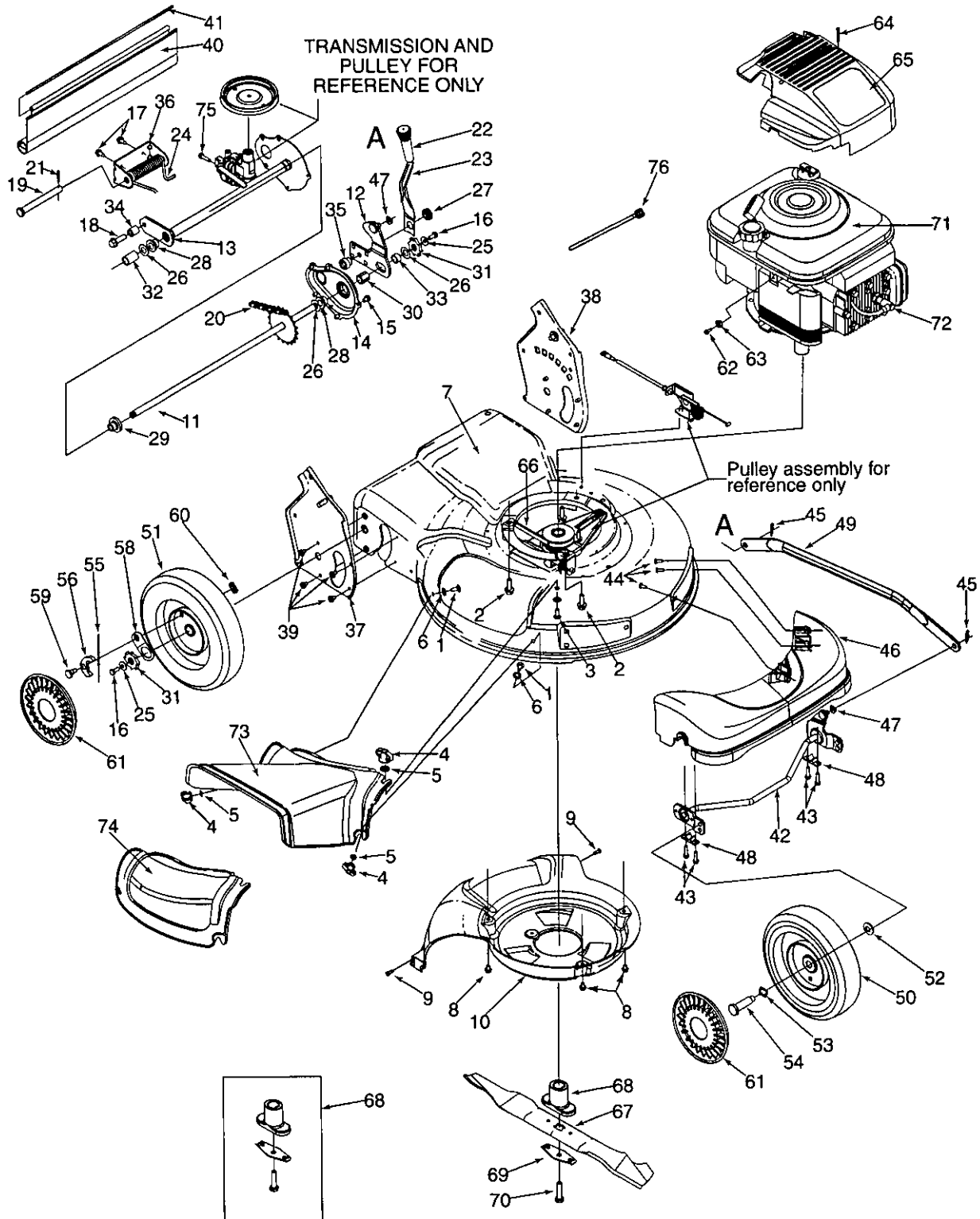

# MODEL 959

Ref. No.	Part No.	Description	Ref. No.	Part No.	Description
1	710-0134	Scr. Carr. 1/4-20 x .62	38	682-3053-0662 N	Handle Brkt. Ass'y. L.H.
2	710-0654A	Scr. TT:3/8-18:1.00	39	710-1348	Scr. AB 1/4-14 x .500
3	710-0703	Scr. 1/4-20 x .750	40	731-1901	N Trail Shield
4	712-0397	Wing Nut 1/4-20	41	732-0842	N Trail Shield Wire
5	723-0233	Nut, Push .25 I.D. x .50 O.D.	42	611-0064-0662 N	Fr. Axle Ass'y.
6	736-0204	Wash. Fl. .334 I.D.x .62 x.03	43	710-1241	Hx Scr. Wash Hd. Hi.-Lo.
7	782-0046-0662 N	Deck - 21"	44	710-1242	Scr. Torx, Truss Hi.-Lo.
8	710-0653	Scr. TT. 1/4-20 x .375	45	714-0104	Cotter Pin .072 x 1.12 Lg.
9	710-1220	Scr. HL. 1/2-14 x .750	46	731-1834	N Fr. Axle Cover
10	731-1828	N Baffle	47	736-0286	Bowed Washer
11	638-0012	N Rear Axle Ass'y	48	741-0492A	Bush. Block .505 Dia. x .62
12	682-0531	N Pivot Arm Ass'y	49	782-0565-0665 N	Control Arm
13	682-7526	N Trans. Axle Ass'y	50	734-1819	N Wheel 8 x 2 Link Gray
14	682-7528	N Chain Cover Ass'y	51	734-1837	N Wheel 9 x 2 Link Gray, Sleeve
15	710-0653	Scr. TT 1/4-20 x .375	52	736-0105	Spr. Wash. .401 x .870 x .063
16	710-0751	Cap Screw HH 1/4-20 x .620	53	736-0504	Wave Wash .510 x .750 x .017
17	710-0896	Scr. AB 1/4-14 x .825	54	738-0102	Shldr Scr .498 x 1.445 x3/8-16
18	710-1315	Scr. 3/8 116 x .25	55	10622B	Spring, Ratchet, Plastic
19	711-0835	Clevis Pin .50 Dia. x 4.82 Lg.	56	748-0381	Pawl - R.H.
20	713-0453	N Chain-Endls. #48 .500P x 24L	57	748-0188B	Pawl - L.H. (Not Illustrated)
21	714-0474	Cotter Pin .125O.D. x .75	58	16855	Ratchet Pawl Plate
22	720-0223	Grip	59	738-0137A	Hubcap - Gray
23	732-0803	N Spring Lever	60	712-0414	Top Lock Tab Weld Nut 1/4-20
24	732-0832	N Torsion Spring	61	731-0981A	Hubcap - Gray
25	736-0270	Bell Wash. .285 x .75 x .082	62	710-1237	Screw .620 Hx. Sit. Wsh.
26	736-0369	Fl. Wash..508 I.D. 1.000 x.020	63	751B213146	Casing Clamp, Throttle
27	738-0529	Nut Shld. .825 Dia. x .165 Lg.	64	710-1256	Scr. Hi-Lo #10 x 1.25
28	741-0324	Hx.Flg. Brg..506 I.D. x .590 L.	65	751B281451	Shroud - Gray
29	741-0522	Hx.Flg. Brg. .506 I.D. x.715 L.	66	754-0460	N Belt
30	741-0978	Hx. Slv. Brg..504 I.D. x .830 L.	67	742-0741	21" Mulching Blade
31	748-0318	Wheel Ratchet	68	753-0609	Blade Adapter Kit
32	750-0151	Spa. .550 I.D. x /750 O.D.	69	736-0524A	Blade Bell Suport
33	750-0515	Spa. .51 .D. x .70 O.D. x 38 L.	70	710-1257	Hex Bolt 3/8-24x2.5"Lg.
34	750-0807	Spa. .385 x .624 x .700	71		Engine
35	750-1056	Shld. Spa. .385 I.D. X .715 Lg.	72	735-0639	Spark Plug Insulator
36	782-0568	Brkt. - Ht. Adj. Spring	73	731-1832	N Side Discharge Chute
37	682-3052-0662 N	Handle Brkt. Ass'y. R.H.	74	731-1833	N Mulch Cover

# MODELS 969/E969

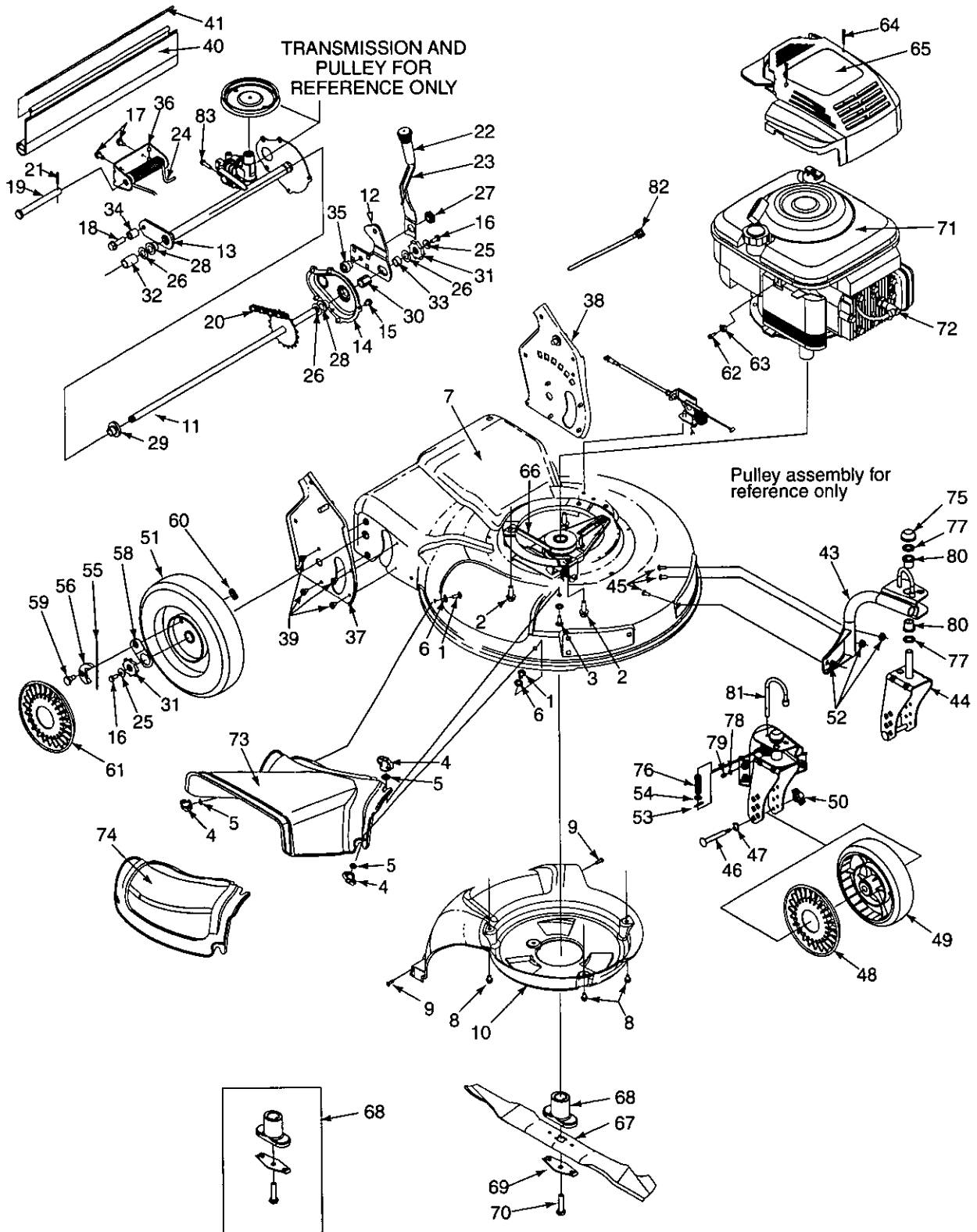



## MODELS 969/E969

Ref. No.	Part No.	Description	Ref. No.	Part No.	Description
1	710-0134	Scr. Carr. 1/4-20 x .62	42	682-9020-0662 N	Caster Ass'y R.H (Not Shown)
2	710-0654A	Scr. TT:3/8-18:1.00	43	682-9021-0662 N	Caster Ass'y L.H.
3	710-0703	Scr. 1/4-20 x .750	44	682-9024-0662 N	Brkt. Ass'y, Wheel Caster
4	712-0397	Wing Nut 1/4-20	45	710-0280	Carr. Bolt 5/16-18 x .62
5	723-0233	Nut, Push .25 I.D. x .50 O.D.	46	711-1146	N Caster Axle .374 Dia. x 2.50"
6	736-0204	Wash. Fl. .334 I.D.x .62 x .03	47	736-0232	Wave Wash.
7	782-0046-0662 N	Deck - 21"	48	731-1887	N Hub Cap Whole Gray
8	710-0653	Scr. TT. 1/4-20 x .375	49	734-1832	N Wheel 7 x 2, Caster Gray BB
9	710-1220	Scr. HL. 1/2-14 x .750	50	712-0397	Wing Nut 1/4-20 Thd.
10	731-1828	N Baffle	51	734-1837	N Wheel 9 x 2 Link Gray, Sleeve
11	638-0012	N Rear Axle Ass'y	52	712-3004A	Lock Nut 5/16-18
12	782-0566	N Pivot Arm Ass'y	53	714-0104	Pin, Cotter .072 x 1.12
13	682-7526	N Trans. Axle Ass'y	54	736-0284	Fl. Wash. .330 x .830 x .06
14	682-7528	N Chain Cover Ass'y	55	10622B	Spring, Ratchet, Plastic
15	710-0653	Scr. TT 1/4-20 x .375	56	748-0381	Pawl - R.H.
16	710-0751	Cap Screw HH 1/4-20 x .620	57	748-0188B	Pawl - L.H. (Not Illustrated)
17	710-0896	Scr. AB 1/4-14 x .825	58	16855	Ratchet Pawl Plate
18	710-1315	Scr. 3/8 116 x .25	59	738-0137A	Shld. Scr. .340 x .285
19	711-0835	Clevis Pin .50 Dia. x 4.82 Lg.	60	712-0414	Top Lock Tab Weld Nut 1/4-20
20	713-0453	N Chain-Endls. #48 .500P x 24L	61	731-0981A	Hubcap - Gray
21	714-0474	Cotter Pin .125O.D. x .75	62	710-1237	Screw .620 Hx. Slit. Wsh.
22	720-0223	Grip	63	751B213146	Casing Clamp, Throttle
23	732-0803	N Spring Lever	64	710-1256	Scr. Hi-Lo #10 x 1.25
24	732-0832	N Torsion Spring	65	751B281451	Shroud - Gray
25	736-0270	Bell Wash. .285 x .75 x .082	66	754-0460	N Belt
26	736-0369	Fl. Wash..508 I.D. 1.000 x .020	67	742-0741	21" Mulching Blade
27	738-0529	Nut Shld. .825 Dia. x .165 Lg.	68	753-0609	Blade Adapter Kit
28	741-0324	Hx.Flg. Brg..506 I.D. x .590 L.	69	736-0524A	Blade Bell Suport
29	741-0522	Hx.Flg. Brg. .506 I.D. x .715 L.	70	710-1257	Hex Bolt 3/8-24x2.5"Lg.
30	741-0978	Hx. Slv. Brg..504 I.D. x .830 L.	71		Engine
31	748-0318	Wheel Ratchet	72	735-0639	Spark Plug Insulator
32	750-0151	Spa. .550 I.D. x /750 O.D.	73	731-1832	N Side Discharge Chute
33	750-0515	Spa. .51 .D. x .70 O.D. x 38 L.	74	731-1833	N Mulch Cover
34	750-0807	Spa. .385 x .624 x .700	75	726-0214	Push Cap
35	750-1056	Shld. Spa. .385 I.D. X .715 Lg.	76	732-0306	Compression Spring
36	782-0568	N Brkt. - Ht. Adj. Spring	77	736-0366	Fl. Wash. 5/8 O.D. x 1" O.D.
37	682-3052-0662 N	Handle Brkt. Ass'y. R.H.	78	736-0931	Fl. Wash. .203 I.D. x .403 O.D.
38	682-3053-0662 N	Handle Brkt. Ass'y. L.H.	79	737-3000	Fitting - Lube
39	710-1348	Scr. AB 1/4-14 x .500	80	741-0685	N Flange Bearing
40	731-1901	N Trail Shield	81	747-0924	Lock Pin
41	732-0842	N Trail Shield Wire	82	725-0157	Cable Tie
			83	710-0604	Hex Scr. 5/16-18

# MODEL E969

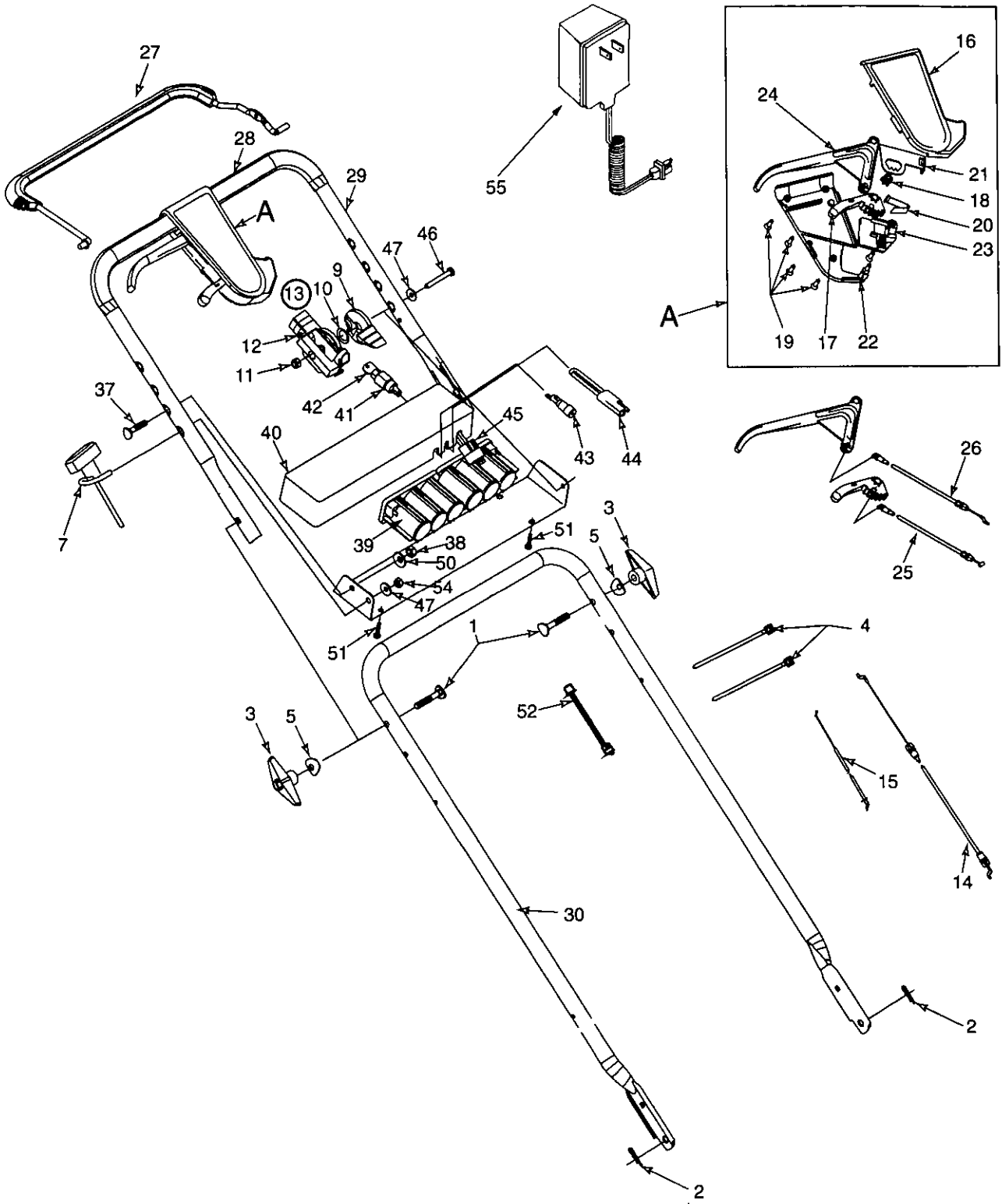

## MODEL E969

Ref. No.	Part No.	Description	Ref. No.	Part No.	Description
1	710-1174	Bolt Cur. Carr. 5/16-18 x 2.0	28	720-0294	Foam Grip (2 Reqd.)
2	714-0104	Cotter Pin .072 x 1.12 Lg.	29	749-0439B	Upper Handle
3	720-0241	Knob Ass'y Wingnut 5/16-18	30	749-0907	Lower Handle
4	726-0240	Strap 4.3 Lg.	31	731-1827	N Grassbag Cover
5	736-0451	Wash. Sad. .320 ID x.830 OD	32	747-0939	N Pivot Rod
7	710-1205	Eyebolt	33	728-0106	Cap Nut
9	746-0876	Throttle Lever	34	747-0937	N Frame - Grassbag
10	736-0501	Spring Wash.Curved	35	747-0940	N Rod, Support
11	712-0324	Nut 1/4-20 Top locknut Insert	36	664-0074	N Grassbag
12	646-0875	Housing, Throttle	37	710-1250	Cur. Carr. Bolt 5/16-18 x 1" Lg.
13	811-00303	Throttle Control - (Includes 9,10,11 & 12)	38	712-0267	Hex Nut 5/16-18 Thd.
14	746-0557	Control Cable 47" Lg.	39	725-1276	Battery Pack - 12 Volt
15	746-0841	Cable Throttle 60" Lg.	40	731-0891A	Battery Tray
16	731-0904	Upper Control Housing	41	725-0873	Ignition Switch
17	731-0924	6 Speed Shift Lever	42	725-0201	Ignition Key
18	713-0397	Gear Insert	43	425-1428	Fuse Holder
				725-0298	Fuse 7-1/2 Amp (Not Ill.)
19	710-0841	C Sunk Tap Screw #10 x .75 L	44	725-1206	Plug
20	732-0627	Shift Lever Spring	45	725-1442	Wire Harness
21	16864	6 Spd. Rack Cable Brkt.	46	710-0501	Hex Bolt 1/4-20 x 2" Lg.
22	731-0905	Lower Control Housing	47	736-0270	Bell Wash 1/4" I.D.
23	731-0906	Cable Mounting Cap	49	782-9012	Lower Battery Tray
24	731-0620	Control Lever	50	736-0242	Bell Wash. 5/16" I.D.
25	746-0939	6 Spd. Cable	51	710-0969	Truss Mch. Tap Scr. 1" Lg.
26	746-0710A	S.P. Cable	52	725-1538	Harness Ext.
27	747-0824	Control Handle	54	712-0287	Hex Nut 1/4-20
			55	725-0727	Battery Charger

## LABELS

Ref. No.	Part No.	Description	Ref. No.	Part No.	Description
N/I	777-1595C	N Danger - Rt. Rear	N/I	777-4725	N White LC 215E Logo ‡
N/I	777-0870	N Danger - Top of Deck	N/I	777-8627	N Drive Lever on Handle
N/I	777-1584	N Danger - On side Discharge Chute	N/I	777-4852	N Wheel Cover Label
N/I	777-5270	N Warning - On Deck above Opening	N/I	777-5645	N Ht. Adj. Label
N/I	777-0148	N Throttle	N/I	777-3541	N Trans. Drive Label
N/I	777-4862	N White LC 210 Logo †	N/I	777-5242	N Caster Wheel Lock ††,‡
N/I	777-4724	N White LC 215 Logo ††	N/I	777-5902	N Electric Start Instructions ‡
			N/I	777-4857	N White - On Battery Pack ‡

† Model 959 only  
 †† Model 969 only  
 ‡ Model E969 only

## MODELS 959/969

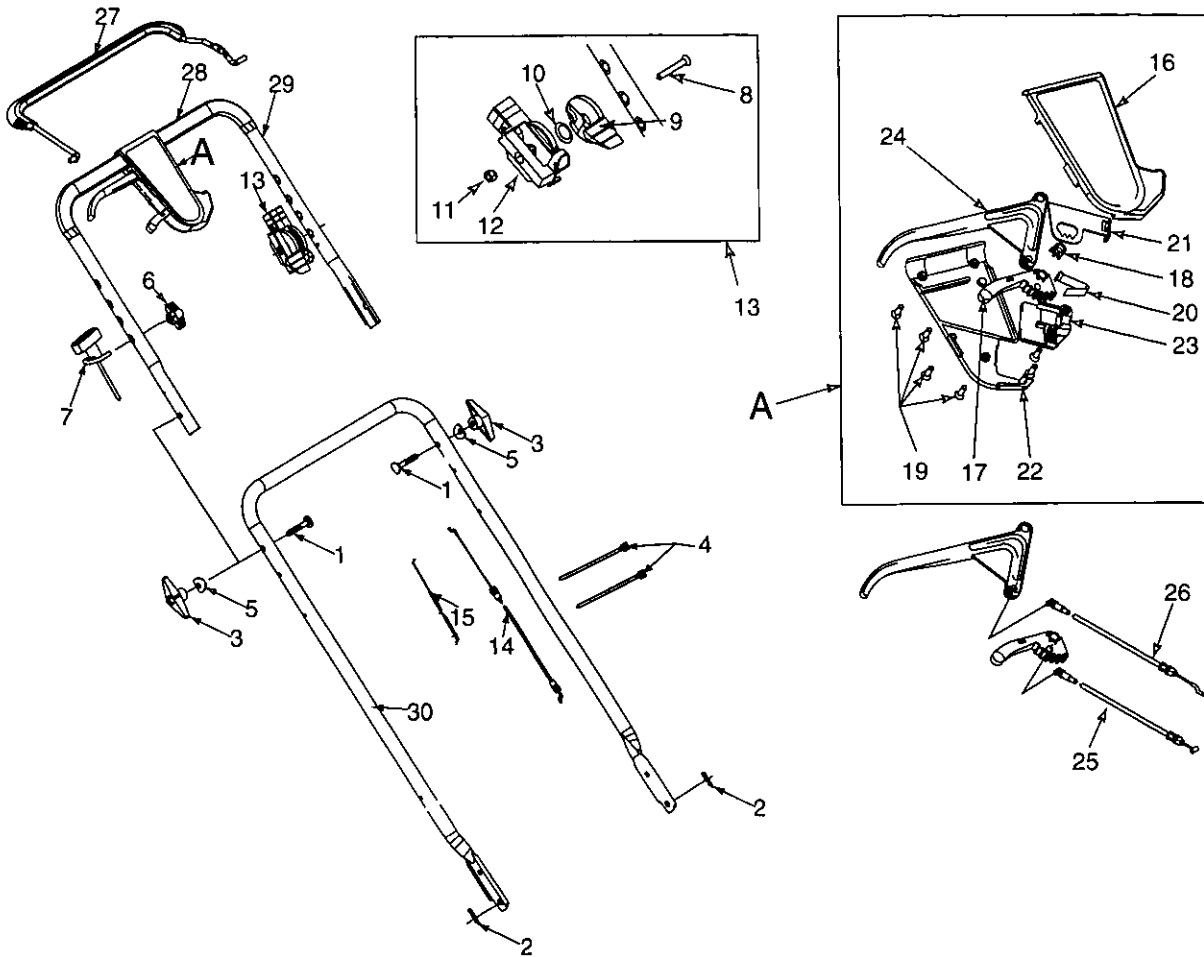

## MODELS 959/969

Ref. No.	Part No.	Description	Ref. No.	Part No.	Description
1	710-1174	Bolt Curv. Carr. 5/16-18 x 2.0	16	731-0904	Upper Control Housing
2	714-0104	Cotter Pin .072 x 1.12 Lg.	17	731-0924	6 Speed Shift Lever
3	720-0241	Knob Ass'y Wingnut 5/16 -18	18	713-0397	Gear Insert
4	726-0240	Strap 4.3 Lg.	19	710-0841	CSunk Tap Scr #10 x .75 L
5	736-0451	Wash. Sad. .320 ID x.830 OD	20	732-0627	Shift Lever Spring
6	720-0279	Knob Handle ERS - 1/4-20	21	16864	6 Spd. Rack Cable Brkt.
7	710-1205	Rope Guide Eyebolt	22	731-0905	Lower Control Housing
8	710-0605	Screw 1/4-20 x 1.81	23	731-0906	Cable Mounting Cap
9	746-0876	Throttle Lever	24	731-0620	Control Lever
10	736-0501	Spring Wash. Curved	25	746-0939	N 6 Spd. Cable
11	712-0324	Nut 1/4-20 Top locknut Insert	26	746-0710A	S.P. Cable
12	646-0875	Housing, Throttle	27	647-0004	Control Handle
13	811-00303	Throttle Control - (Includes 8,9 ,10,11 & 12)	28	720-0294	Foam Grip (2 Reqd.)
14	746-0557	Control Cable 47" Lg.	29	749-0438B	Upper Handle
15	746-0841	Cable Throttle 60" Lg.	30	749-0907	Lower Handle

# MODELS 959/969/E969

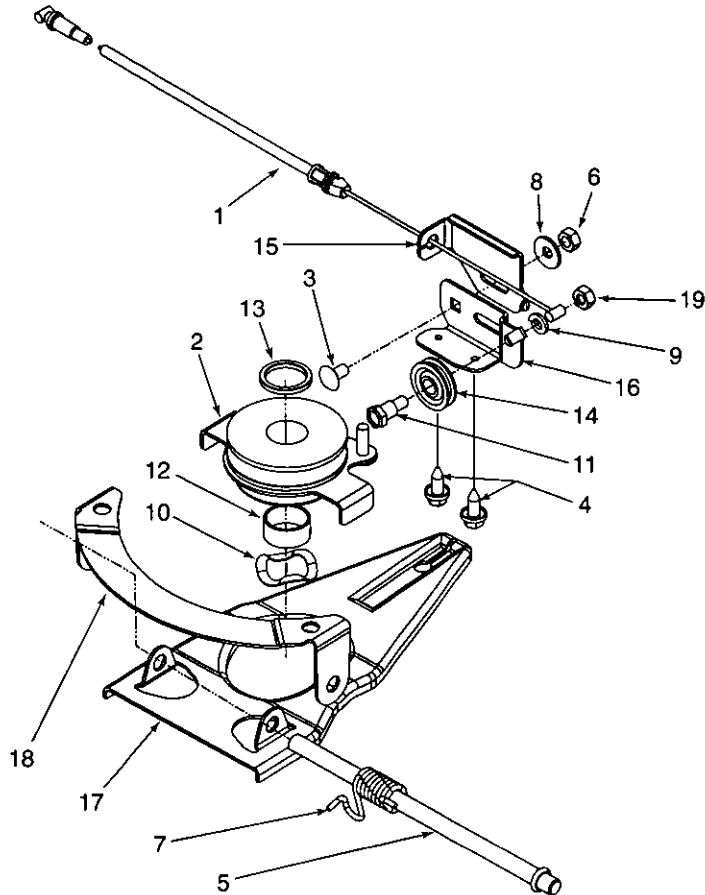

Ref. No.	Part No.		Description
1	746-0939	N	6 Spd. Cable
2	656-0613	N	Pulley Ass'y Mult - Spd.
3	710-0167		Scr. 1/4-20 x .50 Carr.
4	710-0896		Scr. AB 1/4-14 x .625 Hxinwsh
5	711-1114	N	Pivot Shaft
6	712-0287		Nut 1/4-20
7	732-0807	N	Torsion Spring LH
8	736-0270		Bell Wash. .265 X .75 X .062
9	736-0329		Lock Wash. 1/4 Reg Duty
10	736-0526		Wave Wash. 1.38 x .88 x .029
11	738-00924		Shld.Scr. .375 x 1/4 -14AB
12	750-1070		Slev Spcr. .88 ID 1.00 OD x.48
13	750-1071		Slev Spcr .88 ID x 1.13 ID x .12
14	756-0625		Roller Cable
15	782-7574-0662	N	6 Spd. Cable Adj. Bracket
16	782-7575-0662	N	6 Spd. Cable Mt. Bracket
17	782-7596	N	6 Sp. Control Arm
18	782-7597	N	6 Sp. Pivot Bracket
19	712-0138		Hex Nut 1/4-28

# MODELS 959/969/E969

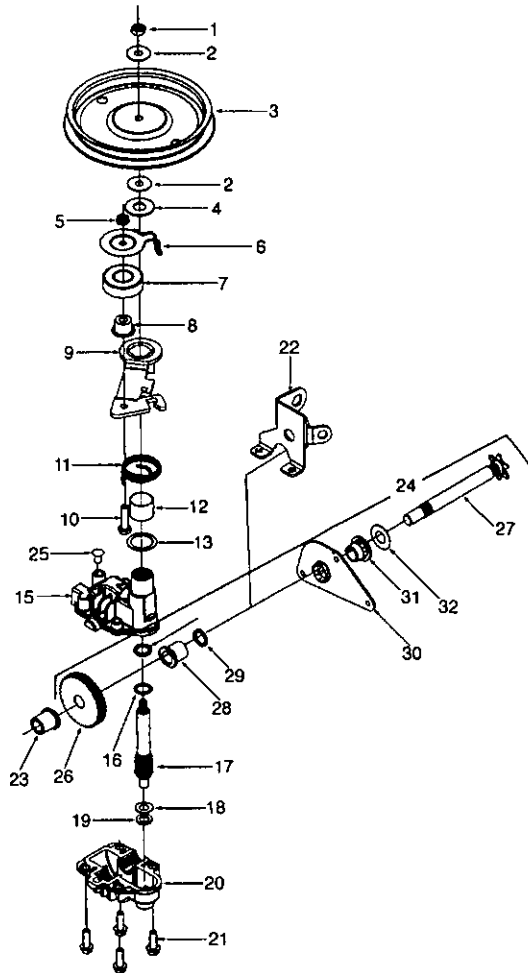

Ref. No.	Part No.	Description	Ref. No.	Part No.	Description
1	712-3025	Hx. Jam Nut 5/16-24	17	717-1468	N Pinion Shaft 10 T.
2	736-0425	Bell Wash. .325 x .930 x .045	18	736-0314	Thr. Wash. 3/8 x .70 x .030
3	756-0656	N Pulley	19	736-0569	N Thr. Wash. .388 x .625 x .062
4	736-3084	Fl. Wash. .510 x 1.120 x .060	20	618-0252	N Lower Housing Ass'y.
5	712-0896	Hx. Jam Nut 1/4-28	21	710-0642	Hx. Scr. 1/2-20 x .75
6	782-7598	N Belt Keeper	22	782-7601	N Cable Bracket
7	741-0600	Bearing	23	741-0674	N Bearing
8	750-1050	N Flange Spacer	24	611-0066	N Shaft Ass'y.
9	682-0027	N Idler Bracket Ass'y.	25	721-0325	Plug
10	710-0299	Hx. Cap Scr. 1/4-28 x 1.00 Gr. 5	26	717-1469	N Gear 34 T.
11	732-0811	N Torsion Spring	27	711-1168	N Output Shaft 6 T.
12	741-0682	N Bearing Sleeve	28	741-0673	N Flange Bearing
13	736-0570	N Fl. Wash. .885 x 1.145 x .030	29	721-0329	Oil Seal
14	721-0329	Oil Seal	30	782-7595	N Pivot Bracket
15	618-0253	N Upper Housing Ass'y.	31	741-0324	Flange Bearing
16	736-0520	N Fl. Wash. .504 x .700 x .030	32	736-0369	Wash. Fl. .508 I.D. x 1.00 O.D. x .020

## MANUFACTURER'S LIMITED WARRANTY FOR:



For TWO YEARS from the date of retail purchase within the United States of America, its possessions and territories, MTD Products will, at its option, repair or replace, for the original purchaser, free of charge, any part or parts found to be defective in material or workmanship. This warranty covers units which have been operated and maintained in accordance with the owner's instructions furnished with the unit, and which have not been subject to misuse, abuse, commercial use, neglect, accident, improper maintenance or alteration.

Normal wear parts or components thereof are subject to separate terms as noted below in the "No Fault Ninety Day Consumer Warranty" clause.

All normal wear part failures will be covered on this product for a period of 90 days regardless of cause. After 90 days, but within the two year period, normal wear parts failures will be covered ONLY IF caused by defects in material or workmanship of OTHER component parts. Normal wear parts are defined as batteries\*, belts, blades, blade adapters, grass bags, rider deck wheels, seats, snow thrower skid shoes, shave plates and tires.

**How to obtain service:** Warranty service is available, with proof of purchase, through your local authorized service dealer. To locate the dealer in your area, please check the yellow pages or contact the Customer Service Department of MTD Products, P O Box 368022, Cleveland, Ohio 44136-9722. Phone 1 (800) 94WHITE. The return of a complete unit will not be accepted by the factory unless prior written permission has been extended by the Customer Service Department of MTD Products.

**Transportation charges:** Transportation charges for the movement of any power equipment unit or attachment are the responsibility of the purchaser.

**Units exported out of the United States:** MTD Products does not extend any warranty for products

sold or exported outside of the United States of America, its possessions and territories, except those sold through MTD Products' authorized channels of export distribution.

### Other Warranties:

1. The engine or component parts thereof carry separate warranties from their manufacturers. Please refer to the applicable manufacturer's warranty on these items.
2. \*Batteries are covered by a 90-day replacement warranty.
3. Log splitter pumps, valves and cylinders or component parts thereof are covered by a one year warranty.
4. All other warranties, express or implied, including any implied warranty of merchantability or fitness for a particular purpose, are hereby expressly disclaimed in their entirety.
5. The provisions as set forth in this warranty provide the sole and exclusive remedy of MTD Products' obligations arising from the sales of its products. MTD Products will not be liable for incidental or consequential loss or damage.

**How state law relates to this warranty:** This limited warranty gives you specific legal rights, and you may also have other rights which vary from state to state. Certain disclaimers are not allowed in some states and therefore they may not apply to you under all circumstances.

**NOTE:** This warranty does not cover routine maintenance items such as lubricants, filters, blade sharpening and tune-ups, or adjustments such as brake adjustments, clutch adjustments or deck adjustments. Nor does this warranty cover normal deterioration of the exterior finish due to use or exposure.



**FOR THE DEALER NEAREST YOU  
CALL  
1-800-9-4-WHITE.**

The only way to ensure the performance of your product is to use original equipment your product is to use original equipment your product is to use original equipment parts and accessories. MTD Products parts and accessories. MTD Products designs and engineers quality parts to exacting specifications. When you substitute, you take a chance on quality, reliability, safety and performance. Use MTD products original equipment parts-See your local White Outdoor dealer!



**WARNING: The Engine Exhaust from this product contains chemicals known to the State of California to cause cancer, birth defects or other reproductive harm.**