

Gas Range

Use and Care Guide

ROPER®

Home Appliances

FGP210V
FLP210V
FGP215V

Thank you for choosing a Roper appliance.

This Use and Care Guide will help you operate and maintain your new, quality-built Roper range. Keep this Use and Care Guide in a safe place for future reference.

Complete and mail the Product Registration Card.

This card enters your warranty into our warranty system that insures efficient claim processing, can be used as a proof of purchase for insurance claims and helps Roper to contact you immediately in the unlikely event of a product-safety recall.

You are responsible for

It is your responsibility to be sure that your range:

- Has been properly installed where it is protected from the elements, and on a floor strong enough to support its weight. (See the Installation Instructions.)
- Is not used by anyone unable to operate it properly.
- Is properly maintained.
- Is used only for jobs expected of a home range.
- Is secured by properly installed anti-tip bracket, with rear of base leg positioned under bracket.

NOTE: Because this Use and Care Guide covers several models, not all illustrations shown or features discussed will apply to your specific model

Contents

	Page
Important Safety Instructions	2
Parts And Features	3
Using Your Range	4
Using the surface burners	4
Lighting standing pilots	5
Using the oven controls	5
The oven vent	6
Caring For Your Range	7
The surface burner grates	7
The removable cooktop	7
The surface burners	7
The removable oven door	8
The standard-cleaning oven	8
The broiler carriage	8
Cleaning chart	9

	Page
Before You Call For Service	11
Warranty	12
How to get service or assistance	12

6/92

Important Safety Instructions

Gas ranges have been thoroughly tested for safe and efficient operation. However, as with any appliance, there are specific installation and safety precautions which must be followed to ensure safe and satisfactory operation.

⚠️ WARNING

To reduce the risk of fire, electrical shock, injury to persons, or damage when using the range, follow basic precautions, including the following:

WARNING: If the information in this manual is not followed exactly, a fire or explosion may result causing property damage, personal injury or death.

DO NOT STORE OR USE GASOLINE OR OTHER FLAMMABLE VAPORS AND LIQUIDS IN THE VICINITY OF THIS OR ANY OTHER APPLIANCE. THE FUMES CAN CREATE A FIRE.

WHAT TO DO IF YOU SMELL GAS:

- **DO NOT TRY TO LIGHT ANY APPLIANCE.**
- **DO NOT TOUCH ANY ELECTRICAL SWITCH; DO NOT USE ANY PHONE IN YOUR BUILDING.**
- **IMMEDIATELY CALL YOUR GAS SUPPLIER FROM A NEIGHBOR'S PHONE. FOLLOW THE GAS SUPPLIER'S INSTRUCTIONS.**
- **IF YOU CANNOT REACH YOUR GAS SUPPLIER, CALL THE FIRE DEPARTMENT. INSTALLATION AND SERVICE MUST BE PERFORMED BY A QUALIFIED INSTALLER, SERVICE AGENCY OR THE GAS SUPPLIER.**

1. Install or locate the range only in accordance with the provided Installation Instructions. The range must be installed by a qualified installer. The range must be properly connected to the proper gas supply and checked for leaks. The range must also be properly connected to electrical supply and grounded.
2. Gas fuels and their use in appliances can cause minor exposures to benzene, formaldehyde, carbon monoxide and soot, primarily from incomplete combustion. Significant exposure to these substances can cause reproductive harm. Properly adjusted burners with a blue, rather than a yellow, flame will minimize incomplete combustion. Venting with a hood or an open window will further minimize exposure.

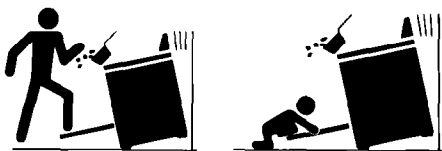

3. **WARNING:** To reduce the risk of tipping of the appliance, the appliance must be secured by properly installed anti-tip bracket. To check if the bracket is installed properly, shine a flashlight under range toward rear corners and verify that the anti-tip bracket is engaged. See Installation Instructions for further details.

4. Do not operate the range if it is damaged or not working properly.
5. **DO NOT** use the range for warming or heating the room. Persons could be burned or injured, or a fire could start.
6. Use the range only for its intended use as described in this manual.
7. **DO NOT** wear loose or hanging garments when using the range. They could ignite if they touch a surface burner and you could be burned.
8. **DO NOT TOUCH SURFACE BURNERS, AREAS NEAR SURFACE BURNERS OR INTERIOR SURFACES OF OVEN.** Areas near surface burners and interior surfaces of an oven become hot enough to cause burns. During and after use, do not touch, or let clothing or other flammable materials contact surface burners, areas near surface burners or interior surfaces of oven until they have had sufficient time to cool. Other surfaces of the range may become hot enough to cause burns; such as, the oven vent opening, the surface near the vent opening, the cooktop and the oven door.
9. Make sure the utensils you use are large enough to contain food and avoid boilovers and spillovers. Heavy splattering or spillovers left on a range can ignite and burn you. Pan size is especially important in deep fat frying.
10. Turn pan handles inward, but not over other surface burners. This will help reduce the chance of burns, igniting of flammable materials, and spills due to bumping of the pan.

11. Use only dry potholders. Moist or damp potholders on surface burners may result in burns from steam. Do not let potholder touch surface burners. Do not use a towel or bulky cloth for a potholder. It could catch on fire.
12. Check to be sure glass cooking utensils are safe for use on the range. Only certain types of glass, glass-ceramic, ceramic, earthenware or other glazed utensils are suitable for cooktops without breaking due to the sudden change in temperature.
13. **DO NOT** use decorative covers or trivets over the surface burners.
14. **DO NOT** heat unopened containers. They could explode. The hot contents could cause burns and container particles could cause injury.
15. **Grease is flammable. DO NOT allow grease to collect around cooktop or in vents.** Wipe spillovers immediately.
16. **DO NOT** use water on grease fires. Never pick up a flaming pan. Smother flaming pan on range by covering with a well-fitted lid, cookie sheet or flat tray. Flaming grease outside of pan can be extinguished with baking soda or, if available, a multipurpose dry chemical or foam-type extinguisher.
17. Never leave surface burners unattended at high heat settings. A boilover could result and cause smoking and greasy spillovers that may ignite.

18. Make sure surface burners are off when you are finished, and when you are not watching.
19. Use care when opening oven door. Let hot air or steam escape before removing or replacing food.
20. Always position oven rack(s) in desired location while oven is cool.
21. DO NOT store flammable materials on or near the range. The fumes can create an explosion and/or fire hazard.
22. DO NOT store things children might want above the range. Children could be burned or injured while climbing on it.
23. Do not use the oven for storage.
24. DO NOT leave children alone or unattended in area where the range is in use. They should never be allowed to sit or stand on any part of the range. They could be burned or injured.
25. **NEVER** use a match or other flame to look for a gas leak. Explosion and injury could result.
26. Know where your main gas shut off valve is located.
27. DO NOT attempt to light the oven burner on electric ignition models during a power failure. Personal injury could result. Reset oven controls to the off position in the event of a power failure.
28. Keep range vents unobstructed.
29. Clean your range regularly. See care and cleaning instructions in this manual.
30. Be sure all range parts are cool before cleaning.
31. DO NOT clean door seal. It is essential for a good seal. Care should be taken not to rub, damage or move the seal. Clean only parts recommended in this Use and Care Guide.
32. DO NOT repair or replace any part of the range unless specifically recommended in this manual. All other servicing should be referred to a qualified technician.
33. Disconnect the electrical supply before servicing the range.

▪ **SAVE THESE INSTRUCTIONS** ▪

Parts & Features

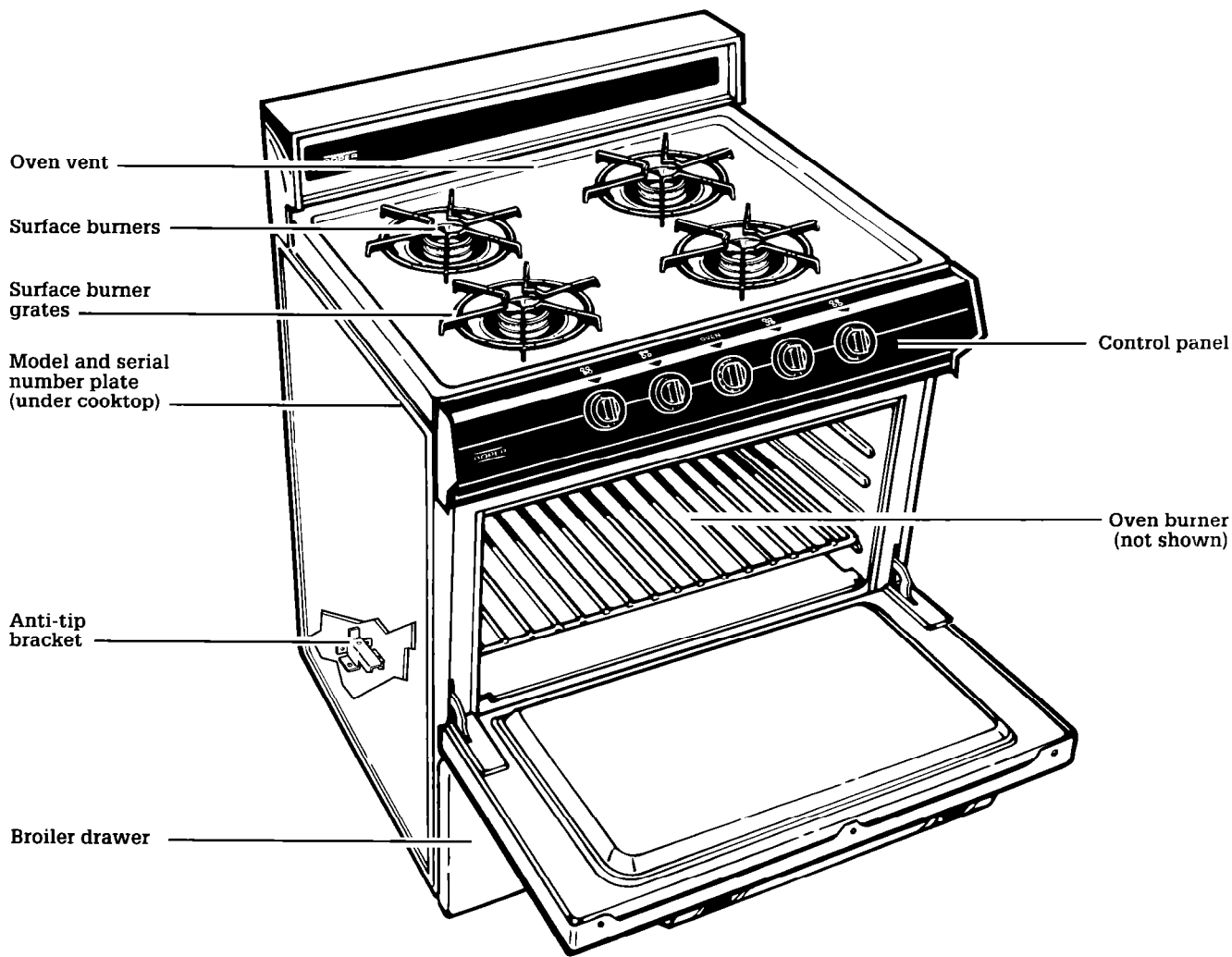

Using Your Range

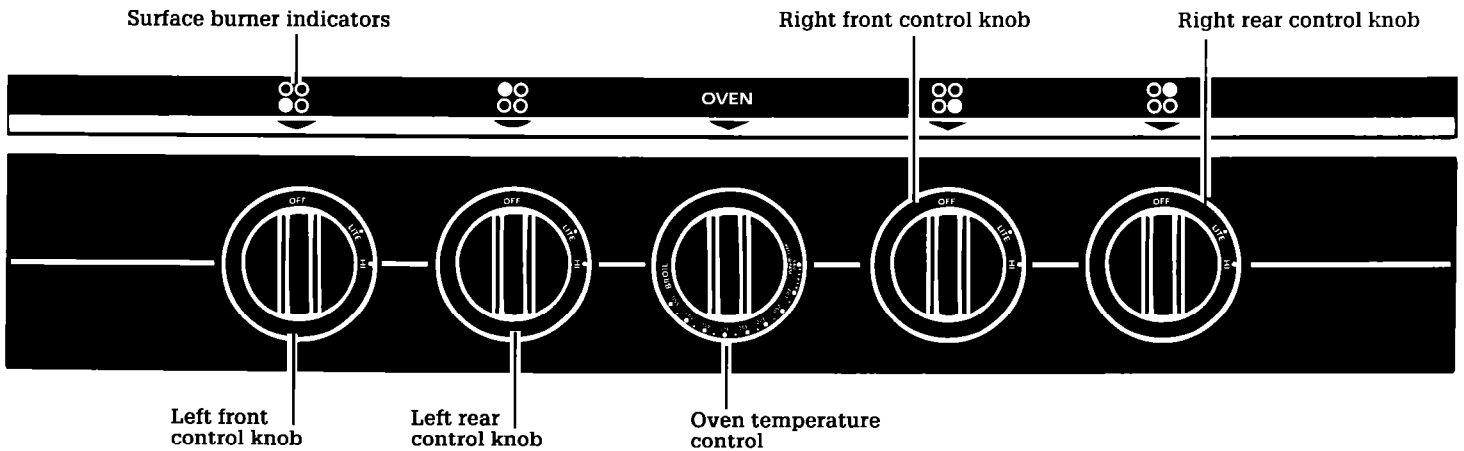

Using the surface burners

Your range is equipped with either standing pilots or electric ignitors. Standing pilots must be lit initially with a match following the directions on page 5. The pilot light will remain lit when the burners are turned off. To turn a burner on again, just push in and turn the control knob to LITE and the burner will light. Electric ignitors automatically light the burners each time the control knob is turned to LITE.

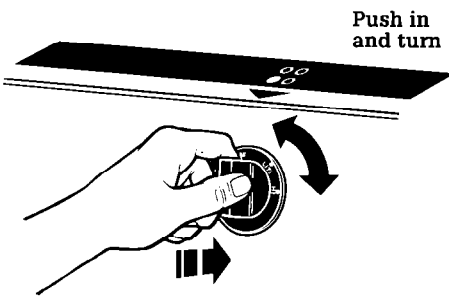

Control knobs must be pushed in and turned to the LITE position. On electric ignitor models, the clicking sound is the ignitor sparking.

After the burner lights, turn the control knob back to a desired setting. The control knob can be set anywhere between HI and low setting. Do not cook with the control in the LITE position.

Surface burner indicators

The solid dot in the surface burner indicator shows which surface burner is turned on by that knob.

Burner heat settings

Use correct heat settings (see below). If the heat setting is too high, it can:

- Char bacon and cause curling.
- Make eggs tough and crisp at the edges.
- Toughen liver, fish and seafood.
- Scorch delicate sauces and custards.
- Cause a boilover.

Until you get used to the settings, use the following as a guide. For best results, start cooking at the high settings, then turn the control knob down to continue cooking.

Use LITE to light the burner. After the burner lights, turn control back to a desired setting.

Use a high setting to start food cooking; to bring liquids to a boil.

Use a medium setting to continue cooking or to fry chicken or pancakes; for gravy, puddings and icing; to cook large amounts of vegetables.

Use a low setting to keep food warm until ready to serve.

NOTE: Do not cook with the control in the LITE position.

In case of a prolonged power failure

Surface burners with electric ignitors can be manually lit. Hold a lit match near a burner and slowly turn the control knob on until the burner lights. After the burner lights, turn the control knob to the desired setting. Power failures will not affect standing pilots.

WARNING

Burn, Fire And Explosion Hazard

- **Burner flame should not extend beyond the edge of the cooking utensil.** The flame can burn you and cause poor cooking results.
- **Be sure all control knobs are turned to OFF when you are not cooking.** Someone could be burned or a fire could start if a burner is accidentally left ON.
- **If the flame should go out while cooking, or if there is a strong gas odor, turn the burners OFF. Wait five minutes for the gas odor to disappear, before relighting burner.** If gas odor is still present, see safety note on page 2. Failure to follow these precautions could result in explosion or fire.

Lighting standing pilots (Model FGP210V)

To light range pilots:

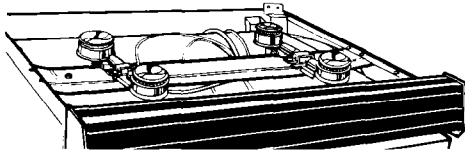

1. Make sure all controls are OFF.
2. Remove the surface burner grates from the cooktop. Remove the cooktop. (See "The removable cooktop" on page 7.)

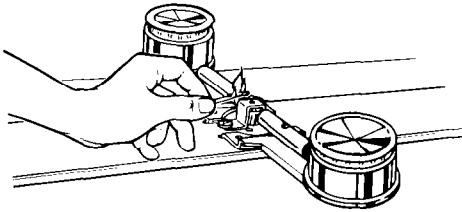

3. **To light**, hold a lit match over the pilot light located between the front and back burners. The pilot flame should be $\frac{1}{4}$ to $\frac{3}{8}$ in. (.6 - 1 cm) high.

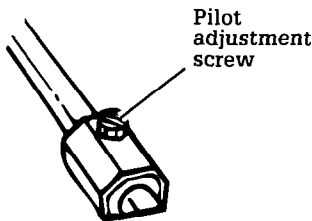

4. If the pilot flame needs adjustment, turn the pilot adjustment screw behind the Oven Temperature Control, under the control panel.
5. Lower the cooktop and replace the grates before using the surface burners.

To light oven burner pilot:

1. Make sure the Oven Temperature Control is OFF.
2. Pull broiler drawer open. Broiler door will tilt down when opened.
3. Remove broiler pan and grid.

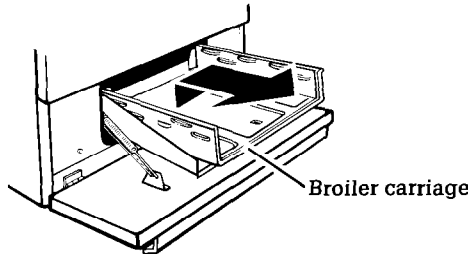

4. Slightly lift broiler carriage and pull all the way out.

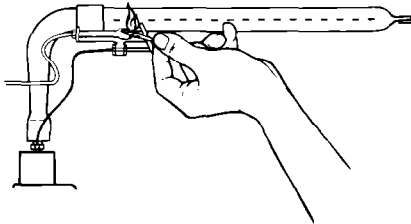

5. Hold a lit match over the oven burner pilot located at the rear of the burner.
6. After the oven burner pilot is burning steadily, check burner lighting by pushing in and turning the Oven Temperature Control to a temperature above 140°F (60°C). The burner will take 50-60 seconds to light.
7. Replace broiler carriage by pushing it in until carriage is locked under placement tab in rear of broiler carriage body. Make sure spring clip at front of carriage snaps into slot in broiler carriage body. **Carriage must be snapped into body whenever you are baking.**
8. Replace broiler pan and grid.
9. Close broiler drawer all the way.

Using the oven controls

Baking/roasting

1. Position the rack(s) properly **before** turning on the oven. **To change rack position**, pull rack out to stop, raise front edge and lift out.

For baking/roasting with one rack, the rack should be placed so the top of the food will be centered in the oven. Always leave at least $1\frac{1}{2}$ to 2 inches (4-5 cm) between the sides of the pan and the oven walls and other pans.

2. Push in and turn the Oven Temperature Control to the baking/roasting temperature you want. The oven burner will automatically light in 50-60 seconds.

3. When baking, preheat the oven for 10 minutes. Put food in the oven.

NOTE: Do not preheat when roasting or cooking items such as casseroles.

Do not place food directly on the oven bottom.

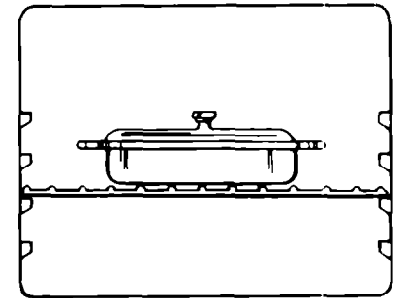

4. During baking/roasting, the oven burner will turn on and off to maintain the temperature setting.
5. When baking/roasting is done, turn the Oven Temperature Control to OFF.

Adjusting the oven temperature control

Does your oven seem hotter or colder than your old oven? The temperature of your old oven may have shifted gradually without you noticing the change. Your new oven is properly adjusted to provide accurate temperatures. But, when compared to your old oven, the new design may give you different results.

If, after using the oven for a period of time, you are not satisfied with the temperature settings, they can be adjusted by following these steps:

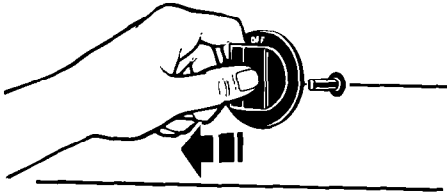

1. Push in and turn the Oven Temperature Control to the off position. Pull knob straight off.

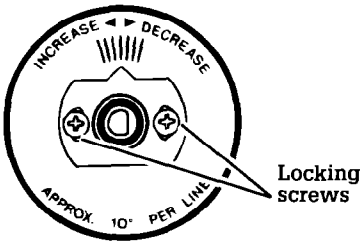

2. Loosen the locking screws. Note the position of the indicator.

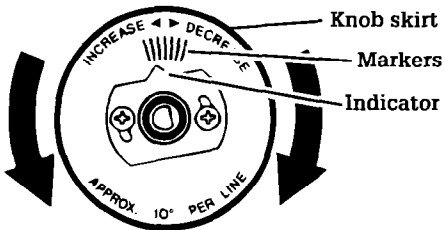

To raise

To lower

3. To lower the temperature, turn knob skirt clockwise to move the indicator one marker line to the left. Each line equals about 10°F (5°C).
4. To raise the temperature, turn knob skirt counterclockwise to move the indicator one marker line to the right. Each line equals about 10°F (5°C).

Tighten the locking screws and replace the control knob.

Broiling

The Broiler Drawer is located below the oven door. **Always broil with the oven door closed.**

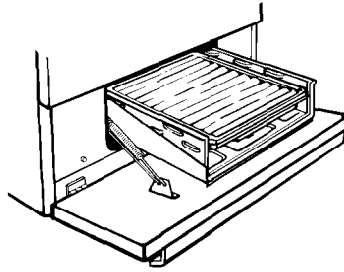

1. Pull the broiler drawer open. Broiler door will tilt down when opened.

CAUTION

Product Damage Hazard
Do not step on or apply excess weight to broiler drawer when open. Doing so can damage the door.

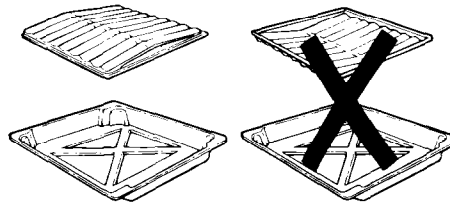

2. Place broiler pan grid so grease can drain down sides into lower part of broiler pan. See picture.
3. Before broiler is turned on, place food on broiler pan and position the broiler pan at one of the three levels. Refer to a broiling chart in a reliable cookbook.
4. Push in and turn the Oven Temperature Control to BROIL. The broiler will automatically light in 50-60 seconds.
5. When broiling is done, turn the Oven Temperature Control to OFF.

NOTE: Do not preheat the broiler before using. Completely close the broiler drawer during broiling.

The oven vent

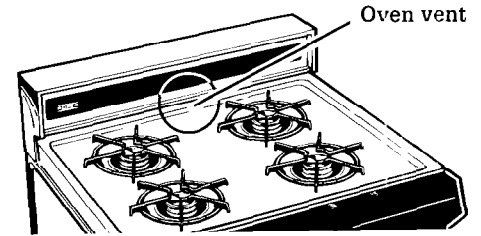

Hot air and moisture escape from the oven through a vent located under the backguard. The vent is needed for air circulation. **Do not block the vent.** Poor baking/roasting will result.

NOTE: Never store plastics, paper or other items that could melt or burn near the oven vent, or any of the surface burners.

WARNING

Burn Hazard

When the oven is ON, pans and pan handles left near the oven vent can become hot enough to burn the user and to melt plastics. Use potholders to move pans.

Caring For Your Range

⚠️ WARNING

Burn, Electrical Shock, Fire And Explosion Hazard

- Make sure all controls are OFF and the range is cool before cleaning.
 - Do not obstruct the flow of combustion and ventilation air.
- Failure to follow these guidelines could result in burns, electrical shock, fire or explosion.

The surface burner grates

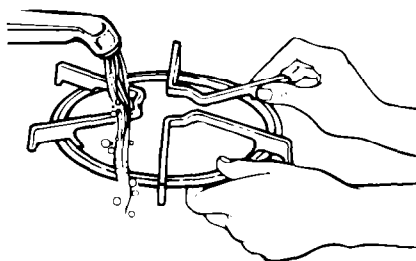

1. Make sure all surface burners are off and the surrounding parts are cool.
2. Lift off the surface burner grates.
3. Wash the grates with warm, soapy water or in a dishwasher. Use a nonabrasive, plastic scrubbing pad for cooked-on foods. Rinse and dry well.
4. Replace burners grates.

The removable cooktop

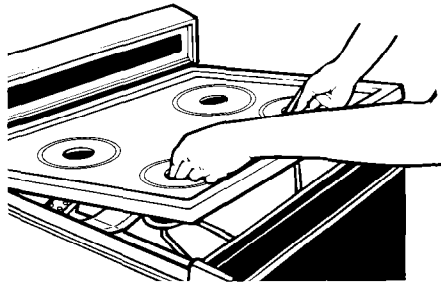

1. Remove surface burner grates.
2. Lift front of cooktop enough to clear front of range. Grasp cool burner openings. Lift and pull forward.
3. Wipe surface under cooktop with sponge and warm, soapy water. Use a soap-filled plastic scrubbing pad on heavily soiled areas.
4. To replace cooktop, lower front of cooktop while placing into rear support brackets. Avoid hitting the control panel.

⚠️ WARNING

Personal Injury And Product Damage Hazard

- Do not try to clean under the cooktop without removing the cooktop first. The cooktop could accidentally fall and injure you.
- Do not drop the cooktop. Damage can result to the finish and the cooktop frame.

The surface burners

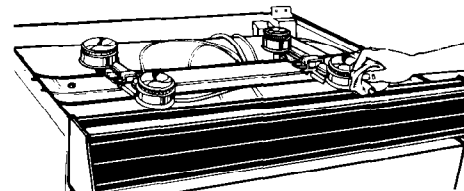

1. Remove the cooktop, following the instructions above.
2. Wipe off surface burners with warm, soapy water and a sponge after each use. To remove cooked-on food, soak the burners in a vinegar and water solution for 20-30 minutes. Scrub with a plastic scrubbing pad.
3. If ports are clogged, clean with a straight pin. **DO NOT enlarge or distort the ports. DO NOT use a toothpick to clean the ports.**

Typical surface burner flame

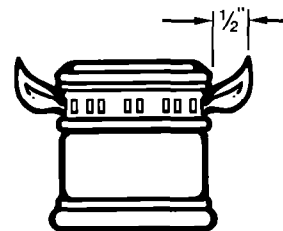

4. Occasionally check the burner flames for proper size and shape as shown above. If flames lift off ports, are yellow, or are noisy when turned off, you may need to clean the burners (see above), or call a qualified technician for adjustment.
5. Replace cooktop.

The removable oven door

Removing the oven door will help make it easier to clean the oven.

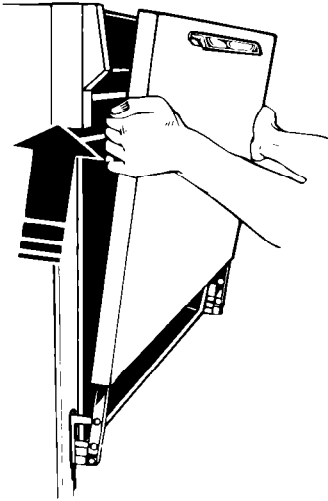

⚠ WARNING

Burn And Electrical Shock Hazard
Make sure all controls are OFF and the oven is cool before removing oven door. Failure to do so can result in burns or electrical shock.

1. Open the door to the first stop position.
2. Hold the door at both sides and lift it at the same angle it is in.
3. **To replace**, fit the bottom corners of the door over the ends of the hinges.

Push the door down evenly. The door will close only when it is on the hinges correctly.

The standard-cleaning oven

The standard-cleaning oven has to be hand-cleaned. Use warm soapy water, soapy steel-wool pads or a commercial oven cleaner. See "Cleaning Chart" on page 10 for further instructions.

⚠ CAUTION

Product Damage Hazard
Do not allow commercial oven cleaner to contact the heat seal, thermostat or exterior surfaces of the oven. Damage will occur.

Using foil

To catch sugar or starchy spills from pies and casseroles, use a piece of heavy-duty aluminum foil or a shallow pan on rack under food container. This may, however, result in poor baking/roasting.

⚠ WARNING

Burn, Electrical Shock And Product Damage Hazard

- Make sure all controls are OFF and the oven is cool before using foil. Failure to do so can result in burns or electrical shock.
- Do not use foil to cover oven floor or to completely cover a rack. Good air circulation is needed for the oven to operate properly. Poor cooking results and damage to the oven could occur.

1. Turn off all controls.
2. **Position foil or pan under the cooking container.** Make sure the foil is centered and large enough to catch any spillovers.

The broiler carriage

The broiler carriage can be removed for ease of cleaning.

To remove:

1. Pull broiler drawer open. Broiler door will tilt down when opened.

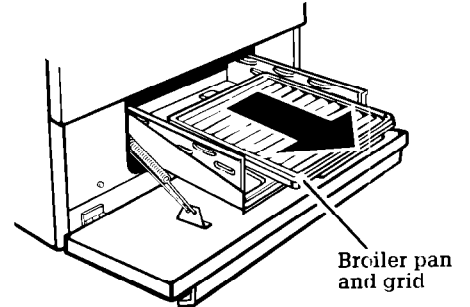

2. Remove broiler pan and grid.

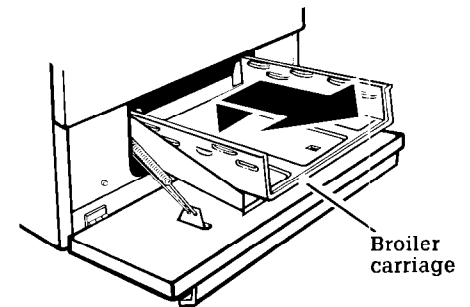

3. Slightly lift broiler carriage and pull all the way out.

To replace:

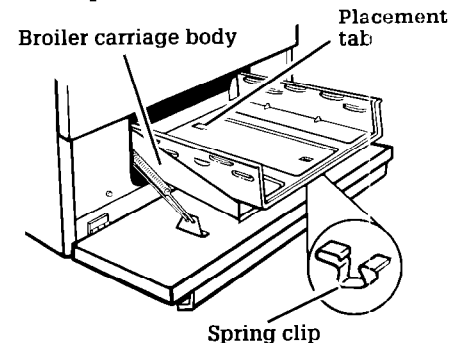

1. Push broiler carriage in until it is locked under placement tab in rear of broiler carriage body. Make sure spring clip at front of carriage snaps into slot in broiler carriage body. **Carriage must be snapped into body whenever you are baking.**
2. Replace broiler pan and grid.
3. Close broiler drawer all the way.

Cleaning chart

WARNING

Burn And Electrical Shock Hazard

Make sure all controls are OFF and the range is cool before cleaning. Failure to do so can result in burns or electrical shock.

PART	WHAT TO USE	HOW TO CLEAN
Control knobs	Sponge and warm, soapy water	<ul style="list-style-type: none"> ▪ Push in and turn knobs to OFF and pull straight away from control panel. ▪ Wash, rinse and dry thoroughly. Do not soak. ▪ Replace knobs. Make sure all knobs point to OFF. <p>DO NOT USE steel wool or abrasive cleaners. They may damage the finish of the knobs.</p>
Control panel	Sponge and warm, soapy water OR Paper towel and spray glass cleaner	<ul style="list-style-type: none"> ▪ Wash, rinse and dry thoroughly. <p>DO NOT USE steel wool or abrasive cleaners. They may damage the finish.</p>
Exterior surfaces (other than control panel)	Sponge and warm, soapy water	<ul style="list-style-type: none"> ▪ Wash, rinse and dry thoroughly. <p>USE nonabrasive, plastic scrubbing pad on heavily soiled areas.</p> <ul style="list-style-type: none"> ▪ Do not use abrasive or harsh cleaners. <p>NOTE: Do not allow foods containing acids (such as vinegar, tomato or lemon juice) to remain on surface. Acids may remove the glossy finish. Also, wipe up milk or egg spills when cooktop is cool.</p>
Surface burner grates	Warm, soapy water and a nonabrasive, plastic scrubbing pad OR Dishwasher	<ul style="list-style-type: none"> ▪ In dishwasher, wash with other cooking utensils. ▪ Dry completely. ▪ Do not use abrasive or harsh cleaners.
Surface burners	Sponge and warm, soapy water Warm, soapy water and a nonabrasive, plastic scrubbing pad OR Vinegar and water solution	<ul style="list-style-type: none"> ▪ Remove the cooktop. (See page 7.) ▪ Wipe off spills immediately after burner has cooled. <p>For cooked-on foods:</p> <ul style="list-style-type: none"> ▪ Remove burner from manifold with Phillips screwdriver. ▪ Wash with warm, soapy water and a plastic scrubbing pad or soak in vinegar and water solution. ▪ Rinse and dry thoroughly. ▪ If ports are clogged, clean with a straight pin. Do not enlarge or distort ports. Do not use a wooden toothpick. ▪ Do not clean surface burner in dishwasher.
Broiler drawer, pan and grid (clean after each use)	Steel-wool pad and warm, soapy water	<ul style="list-style-type: none"> ▪ Clean after each use. ▪ Wash, rinse and dry thoroughly. ▪ After broiler is cool, wipe interior with warm, damp sponge. For heavily soiled areas, use a soapy steel-wool pad.
Oven racks	Steel-wool pad and warm, soapy water	<ul style="list-style-type: none"> ▪ Wash, rinse and dry thoroughly.

Continued on next page

PART	WHAT TO USE	HOW TO CLEAN
Oven cavity	<p>Sponge and warm, soapy water</p> <p>Soapy steel-wool pad for heavily soiled areas OR Commercial oven cleaner for heavily soiled areas</p>	<ul style="list-style-type: none"> ▪ Make sure oven is cool. ▪ Remove door for easier access. (See page 8.) ▪ Wash, rinse and dry thoroughly. ▪ Remove door for easier access. ▪ Rinse thoroughly with water. ▪ Remove door for easier access. ▪ Place newspaper on floor to protect floor surface. ▪ Follow directions provided with the oven cleaner. ▪ Rinse thoroughly with clear water. ▪ Use in a well-ventilated room. ▪ Do not allow commercial oven cleaners to contact the heat seal, thermostat or exterior surfaces of the range. Damage will occur.

Before You Call For Service

If you are having an operating problem, check the chart to see what the cause might be before you call for assistance.

OPERATING PROBLEM	CHECK IF	WHAT TO DO
Nothing operates.	<ul style="list-style-type: none"> ▪ The power cord is plugged into a live circuit with proper voltage. ▪ Range is properly connected to gas supply. ▪ Household fuse has blown or circuit breaker has tripped. ▪ Control knob is set in the correct position. ▪ The flow of combustion and/or ventilation air to the range is blocked. 	<ul style="list-style-type: none"> ▪ Plug the power cord into a live circuit with proper voltage. (See Installation Instructions.) ▪ Contact an authorized Roper service technician to reconnect range to gas supply. (See Installation Instructions.) ▪ Replace fuse or reset circuit breaker. ▪ Set control knob correctly, if needed. ▪ Remove blockage to airflow to and around range.
Oven will not operate.	<ul style="list-style-type: none"> ▪ Oven Temperature Control is turned to a temperature setting. ▪ Pilot is extinguished on standing pilot model. 	<ul style="list-style-type: none"> ▪ Push in and turn Oven Temperature Control to the desired temperature setting, if needed. ▪ Light pilot. (See "Lighting standing pilots" on page 5.)
Burner fails to light.	<ul style="list-style-type: none"> ▪ The power cord is plugged into a live circuit with proper voltage. ▪ Household fuse has blown or circuit breaker has tripped. ▪ Burner ports are clogged. ▪ Pilot is extinguished on standing pilot model. 	<ul style="list-style-type: none"> ▪ Plug the power cord into a live circuit with proper voltage. (See Installation Instructions.) ▪ Replace fuse or reset circuit breaker. ▪ Clean with a straight pin (see pages 7 and 9). ▪ Light pilot. (See "Lighting standing pilots" on page 5.)
Burner flames are uneven.	<ul style="list-style-type: none"> ▪ Burner ports are clogged. 	<ul style="list-style-type: none"> ▪ Clean with a straight pin (see pages 7 and 9). If this fails, call an authorized Roper service technician for service.
Burner flames lift off ports, are yellow, or are noisy when turned off.		<ul style="list-style-type: none"> ▪ Contact an authorized Roper service technician to check air/gas mixture.
Burner makes popping noise when on.	<ul style="list-style-type: none"> ▪ Burner is wet from washing. 	<ul style="list-style-type: none"> ▪ Let dry.
Control knob(s) will not turn.	<ul style="list-style-type: none"> ▪ You pushed in knob(s) before trying to turn. 	<ul style="list-style-type: none"> ▪ Push in knob(s) before turning to a setting.
Cooking results are not what you expected.	<ul style="list-style-type: none"> ▪ The range is level. ▪ The oven temperature seems too high or too low. ▪ The oven was preheated as the recipe calls for. ▪ You are following a tested recipe from a reliable source. ▪ Pans are the type and size called for in the recipe. ▪ When baking, there is proper air circulation around pans. ▪ Flame size fits the cooking utensil being used. ▪ When broiling, you have completely closed the broiler drawer. 	<ul style="list-style-type: none"> ▪ Level range. (See Installation Instructions.) ▪ Adjust the Oven Temperature Control. (See "Adjusting the oven temperature control" on page 6.) ▪ Preheat the oven if called for in the recipe. ▪ Use only tested recipes from a reliable source. ▪ Refer to a reliable cookbook for recommended pan types and sizes. ▪ Allow 1½ to 2 inches (4-5 cm) on all sides of the pans for air circulation. ▪ Adjust flame size to fit cooking utensil. ▪ Completely close broiler drawer.

LIMITED WARRANTY



Home Appliances

LENGTH OF WARRANTY (From date of purchase)	PRODUCTS COVERED	WHAT WE WILL PAY FOR
FULL ONE YEAR WARRANTY	All Roper Appliances	Replacement parts and repair labor to correct defects in materials or workmanship.
FULL FIVE YEAR WARRANTY	Refrigerators Freezers Air Conditioners Dehumidifiers	Replacement parts and repair labor for the sealed refrigeration system (compressor, evaporator, condenser, drier or connecting tubing) which we find to be defective in materials or workmanship.
LIMITED 2ND-5TH YEAR WARRANTY	Microwave Ovens	Repair or replacement of magnetron tube which we find to be defective in materials or workmanship.
LIMITED 2ND-5TH YEAR WARRANTY	Automatic Washers	Repair or replacement of any part of the gear case assembly which we find to be defective in materials or workmanship.

WHAT WE WILL NOT PAY FOR

A. SERVICE CALLS TO:

1. Correct the installation of your appliance.
2. Instruct you how to use your appliance.
3. Replace house fuses or correct house wiring or plumbing.
4. Replace owner accessible light bulbs.

B. Repairs when appliance is used in other than normal, single-family household use.

C. Pickup and delivery. Your appliance is designed to be repaired in the home.

D. Damage to appliance caused by accident, misuse, fire, flood, acts of God, or use of product not approved by us.

E. Any labor costs during the limited warranties.

F. Repairs to parts or systems caused by unauthorized modifications made to the appliance.

This Roper appliance is warranted by Whirlpool Corporation. Under no circumstances shall it be liable under this warranty for incidental or consequential damages and all implied warranties are limited to the same time periods stated in the express warranties for Roper Brand Appliances. Some states do not allow the exclusion or limitation of incidental or consequential damages or limitations of how long an implied warranty may last, so the above limitations or exclusions may not apply to you.

This warranty gives you specific legal rights, and you may also have other rights which vary from state to state.

Outside the United States, a different warranty may apply. For details, please contact your franchised Roper distributor or military exchange.

HOW TO GET SERVICE OR ASSISTANCE

If you need service, first see the "Before You Call For Service" section of this book. If you still need service after checking this section, additional help can be found if you:

- Contact your selling dealer for the authorized servicer in your area*

OR

- Phone **1-800-44-ROPER** (1-800-447-6737) between 8:00 a.m. and 4:30 p.m. Eastern Time, Monday through Friday*

OR

- For further information, write to: Consumer Relations Dept., Roper Brand Appliances, 2000 M-63 North, Benton Harbor, MI 49022*

*When requesting assistance, please provide the model and serial numbers, date of purchase, and a complete description of the problem. The model and serial numbers are located beneath the removable cooktop (see illustration on page 3).

If you are not satisfied with the service received, contact the Major Appliance Consumer Action Panel (MACAP). MACAP is a group of independent consumer experts that voices consumer views at the highest levels of the major appliance industry.

Contact MACAP only when the dealer, authorized servicer and Roper Brand Appliance warrantor have failed to resolve your problem:

Major Appliance Consumer Action Panel
20 North Wacker Drive
Chicago, IL 60606

MACAP will in turn inform us of your action.