

SABER™ **GLIDE**

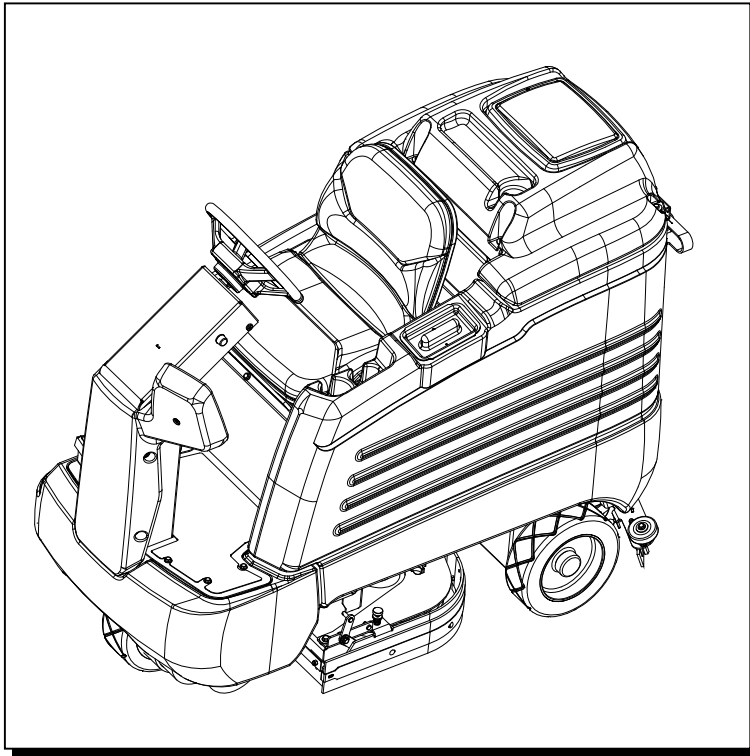

SCRUBBER



Operating Instructions

MODELS: SGJ32
10052530
AFTER SN: 1000136404

QUEST® ... for Continuous Improvement.
Windsor's Quality Management System is Certified ISO 9001.

Read these instructions before using the machine



MACHINE DATA LOG/OVERVIEW

MODEL _____

DATE OF PURCHASE _____

SERIAL NUMBER _____

SALES REPRESENTATIVE # _____

DEALER NAME _____

OPERATIONS GUIDE NUMBER _____

PUBLISHED _____

YOUR DEALER

Name: _____

Address: _____

Phone Number: _____

OVERVIEW

The Saber Glide is a battery powered, ride-on, hard floor scrubber intended for commercial use. The appliance applies a cleaning solution onto a hard floor, scrubs the floor with brushes or pads, and then vacuums the soiled water back into the recovery tank.

TABLE OF CONTENTS

Machine Data Log/Overview.....	2
Table of Contents.....	3

HOW TO USE THIS MANUAL

How to use this Manual.....	1-1
-----------------------------	-----

SAFETY

Important Safety Instructions	2-1
Hazard Intensity Level.....	2-2
Safety Label Location.....	2-3

OPERATIONS

Technical Specifications.....	3-1
How the Machine Works.....	3-3
Components.....	3-4
Controls.....	3-5
Machine Operation.....	3-14
Pre-Run Machine Inspection	3-14
Starting Machine.....	3-14
Filling the Solution Tank.....	3-14
Scrubbing.....	3-14
Emergency Stop Procedures.....	3-15
Emptying & Cleaning Tanks.....	3-16

MAINTENANCE

Maintenance.....	4-1
Batteries.....	4-2
Battery Maintenance.....	4-2
Checking Battery Specific Gravity.....	4-2
Charging the Batteries.....	4-3
Changing Batteries.....	4-4
Battery Connections.....	4-4
Squeegee.....	4-5
Adjusting Pitch	4-5
Replace/Rotate Rear Squeegee Blade.....	4-6
Removing Squeegee Assembly.....	4-6
Replace/Rotate Front Squeegee Blade	4-6
Side Squeegee.....	4-7
Replace/Rotate Side Squeegee Blades.....	4-7
Adjusting the Side Squeegee Deflection.....	4-7
Scrub Brush Replacement.....	4-8
Brake.....	4-9
Steering Chain Tensioner	4-9
Vacuum Motor.....	4-10
Brush Motor.....	4-11
Traction Motor.....	4-12
Fuse	4-12
Circuit Breakers.....	4-12
Squeegee Actuator	4-13
Scrub Deck Actuator	4-14
Transporting Machine	4-15
Jacking Machine	4-16

Service Schedule.....	4-17
Machine Troubleshooting.....	4-18

GROUP PARTS LIST

Brake.....	5-1
Circuit Breaker.....	5-3
Control Panel.....	5-5
Decal.....	5-7
Front Bumper & Floor.....	5-9
Fwd/Rev Pedal.....	5-11
Scrub Brush/Driver	5-13
Scrub Deck Lift-32 in.....	5-15
Scrub Deck-32 in.....	5-17
Scrub Deck Side Squeegee-32 in.....	5-19
Seat & Side Cover.....	5-21
Solution Delivery	5-23
Squeegee -32 in	5-25
Squeegee Lift	5-27
Steering-Upper.....	5-29
Steering-Lower.....	5-31
Tank	5-33
Tank Cover.....	5-35
Vacuum	5-37
Wheel & Frame	5-39
Wiring-Battery.....	5-41
Wiring-Main Harness.....	5-43
Wiring-Main Harness Connection	5-45
Wiring-Control Panel Group	5-47
Wiring-Drive Motor	5-49
Wiring Diagram.....	5-51
Suggested Spare Parts	5-52
Serial Numbers.....	5-53

HOW TO USE THIS MANUAL

This manual contains the following sections:

- HOW TO USE THIS MANUAL
- SAFETY
- OPERATIONS
- MAINTENANCE
- PARTS LIST

The HOW TO USE THIS MANUAL section will tell you how to find important information for ordering correct repair parts.

Parts may be ordered from authorized Windsor dealers. When placing an order for parts, the machine model and machine serial number are important. Refer to the MACHINE DATA box which is filled out during the installation of your machine. The MACHINE DATA box is located on the inside of the front cover of this manual.

MODEL _____
DATE OF PURCHASE _____
SERIAL NUMBER _____
SALES REPRESENTATIVE # _____
DEALER NAME _____
OPERATIONS GUIDE NUMBER _____
PUBLISHED _____

Copyright 2002 Windsor Industries, Printed in USA

The model and serial number of your machine are located to the front of the battery compartment for the machine.

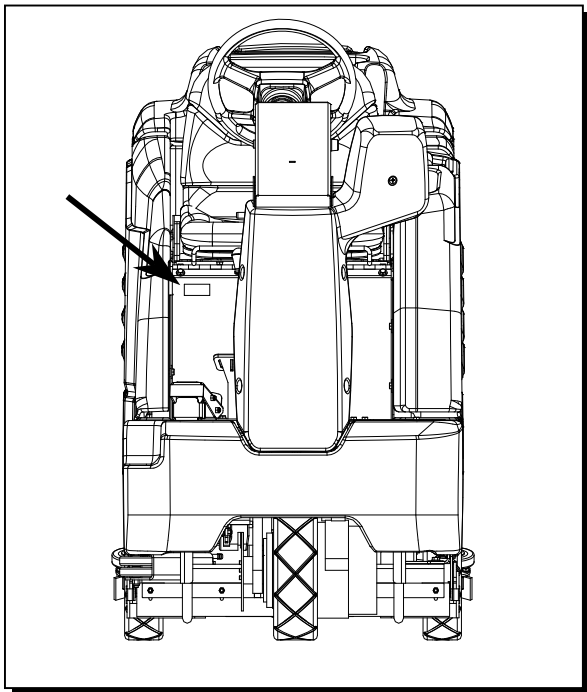

The SAFETY section contains important information regarding hazard or unsafe practices of the machine. Levels of hazards are identified that could result in product or personal injury, or severe injury resulting in death.

The OPERATIONS section is to familiarize the operator with the operation and function of the machine.

The MAINTENANCE section contains preventive maintenance to keep the machine and its components in good working condition. They are listed in this general order:

- Batteries
- Scrub Brushes
- Adjusting Squeegee
- Service Schedule
- Machine Troubleshooting

The PARTS LIST section contains assembled parts illustrations and corresponding parts list. The parts lists include a number of columns of information:

- **REF** – column refers to the reference number on the parts illustration.
- **PART NO.** – column lists the part number for the part.
- **PRV NO.** – reference number
- **QTY** – column lists the quantity of the part used in that area of the machine.
- **DESCRIPTION** – column is a brief description of the part.
- **SERIAL NO. FROM** – If this column has an (*) and a Reference number, see the SERIAL NUMBERS page in the back of your manual. If column has two asterisk (**), call manufacturer for serial number. The serial number indicates the first machine the part number is applicable to. The main illustration shows the most current design of the machine. When a boxed illustration is shown, it displays the older design.
- **NOTES** – column for information not noted by the other columns.

NOTE: If a service or option kit is installed on your machine, be sure to keep the KIT INSTRUCTIONS which came with the kit. It contains replacement parts numbers needed for ordering future parts.

NOTE: The number on the lower left corner of the front cover is the part number for this manual.

IMPORTANT SAFETY INSTRUCTIONS

When using an battery powered appliance, basic precaution must always be followed, including the following:

READ ALL INSTRUCTIONS BEFORE USING THIS MACHINE.



WARNING:

To reduce the risk of fire, electric shock, or injury:

Use only indoors. Do not use outdoors or expose to rain.

Use only as described in this manual. Use only manufacturer's recommended components and attachments.

If the machine is **not working properly**, has been dropped, damaged, left outdoors, or dropped into water, return it to an authorized service center.

Do not operate the machine with any openings blocked. Keep openings free of debris that may reduce airflow.

This machine **is not** suitable for picking up hazardous dust.

Machine can cause a fire when operating near flammable vapors or materials. Do not operate this machine near flammable fluids, dust or vapors.

This machine is suitable for commercial use, for example in hotels, schools, hospitals, factories, shops and offices for more than normal housekeeping purposes.

Maintenance and repairs **must be done** by qualified personnel.

If foam or liquid comes out of machine, **switch off immediately**.

Disconnect battery before cleaning or servicing.

Before the machine is discarded, the batteries **must be removed** and properly disposed of.

Make sure all warning and caution labels **are legible and properly attached** to the machine.

During operation, attention shall be paid to other persons, especially children.

Before use all covers and doors shall be put in the positions specified in the instructions.

When leaving unattended, secure against unintentional movement.

The machine shall only be operated by instructed and authorized persons.

When leaving unattended, switch off or lock the main power switch to prevent unauthorized use.

Only chemicals recommended by the manufacturer shall be used.

This appliance has been designed for use with the brushes specified by the manufacturer. The fitting of other brushes may affect its safety.

SAVE THESE INSTRUCTIONS

HAZARD INTENSITY LEVEL

The following symbols are used throughout this guide as indicated in their descriptions:

HAZARD INTENSITY LEVEL

There are three levels of hazard intensity identified by signal words -**WARNING** and **CAUTION** and **FOR SAFETY**. The level of hazard intensity is determined by the following definitions:

⚠ WARNING

WARNING - Hazards or unsafe practices which COULD result in severe personal injury or death.

⚠ CAUTION

CAUTION - Hazards or unsafe practices which could result in minor personal injury or product or property damage.

FOR SAFETY: To identify actions which must be followed for safe operation of equipment.

Report machine damage or faulty operation immediately. Do not use the machine if it is not in proper operating condition. Following is information that signals some potentially dangerous conditions to the operator or the equipment. Read this information carefully. Know when these conditions can exist. Locate all safety devices on the machine. Please take the necessary steps to train the machine operating personnel.

FOR SAFETY:

DO NOT OPERATE MACHINE:

Unless Trained and Authorized.

Unless Operation Guide is Read and understood.

In Flammable or Explosive areas.

In areas with possible falling objects.

WHEN SERVICING MACHINE:

Avoid moving parts. Do not wear loose clothing; jackets, shirts, or sleeves when working on the machine. Use Windsor approved replacement parts.

⚠ WARNING

Batteries emit hydrogen gas. Explosion or fire can result. Keep sparks and open flame away. Keep solution tank in raised position when charging. Keep sparks and flames away from the batteries. Do not smoke around batteries.

⚠ WARNING

Disconnect batteries before working on machine. Only qualified personnel should work inside machine. Always wear eye protection and protective clothing when working on or near batteries. Avoid skin contact with the acid contained in the batteries.

⚠ WARNING

Never allow metal to lie across battery tops.

SAFETY LABEL LOCATION

NOTE: These drawings indicate the location of safety labels on the machine. If at any time the labels become illegible, promptly replace them.



SAFETY DECAL
86242480
PRV NO. 500111



BRUSH CAUTION
86242510
PRV NO. 500115

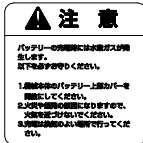
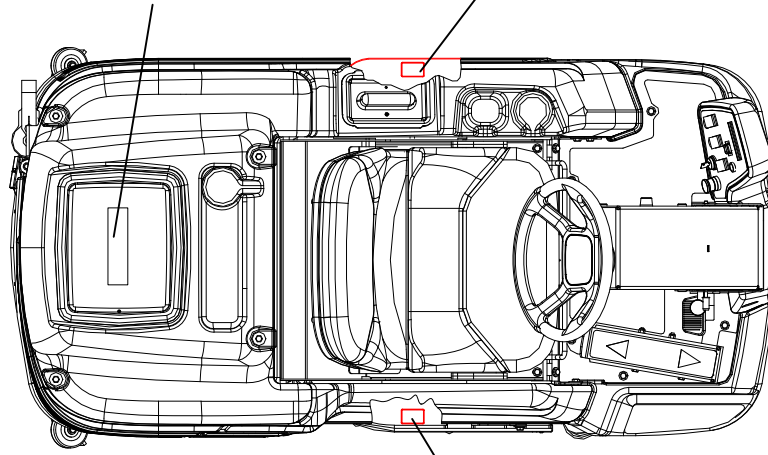

BATTERY CAUTION
86248210
PRV NO. 500109

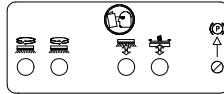

CIRCUIT BREAKER
86244130
PRV NO. 500859



BRUSH CAUTION
86242510
PRV NO. 500115

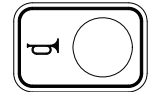

HORN DECAL
86248210
PRV NO. 81349

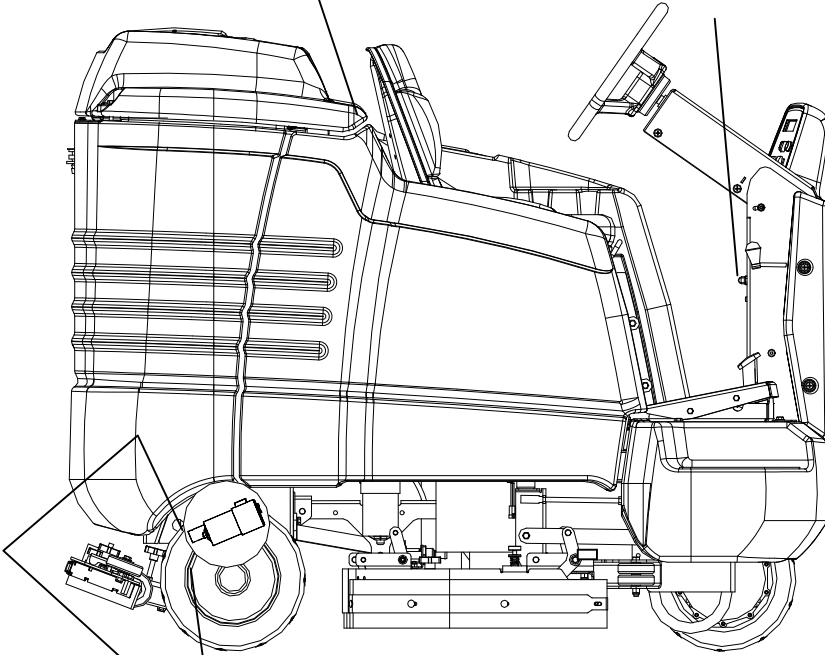

PINCH POINT WARNING
86243830
PRV NO. 500663 (2)

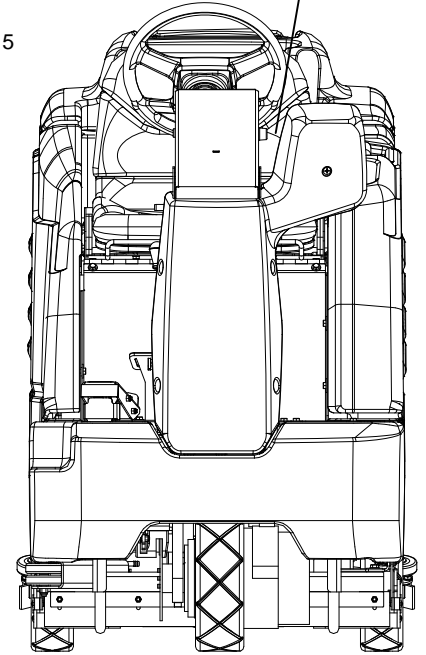

TECHNICAL SPECIFICATIONS

ITEM	DIMENSION/CAPACITY
Nominal power	2.9 kW
Rated Voltage	36 Volts DC
Rated Amperage	80 amps
Batteries	6 x 6 Volt 250-335 AH @20 hr. rate
Scrub Brush Motors	2 x 1.0 HP (746 W)
Vacuum Motor(s)	1 x .75 HP (560 W) Standard, second motor optional
Propelling Motor	1.3 HP (932 W)
Mass (GVW)	1810 lbs (820 kg)
Weight empty without batteries	790 lbs (360 kg)
Solution Control	Gravity feed, fully variable with automatic shut off in neutral
Solution tank capacity	30 gal (115 L)
Recovery tank capacity	30 gal (115 L)
Scrub brush diameter for 32 in. (81 cm) disk scrub head	16 inch (40.6 cm)
Scrub brush pressure	0-225 lbs (0-1000N)
Scrub brush speed	300 rpm
Tires	12 in. (30.5 cm) Solid Scrubber Compound
Foundation Pressure	108 lbs./in ² (745 kPa)
Maximum Speed	4.1 miles/hour (6.5 Km/hour)
Coverage with 32 in. (81 cm) scrub head	48,840 ft ² /hr @ 3.7 mph with 2 in. overlap
Frame Construction	Powder coated steel
Brakes	Self centering mechanical 7 in. (17.7 cm) disc with hand lock parking brake
Minimum aisle u-turn width 32 in. (81 cm) disk scrub head	66 inches (168 cm)
Maximum rated climb and descent angle	7.5 degrees

TECHNICAL SPECIFICATIONS

ITEM	MEASURE
Height 1	51 inches (130 cm)
Height 2	56.6 inches (144 cm)
Length	63.5 inches (161 cm)
Width without squeegee and scrub head	31 inches (79 cm)
Width of squeegee	33 inches (84 cm)
Width of scrub path for 32 in. (81 cm)	32 inches (81 cm)

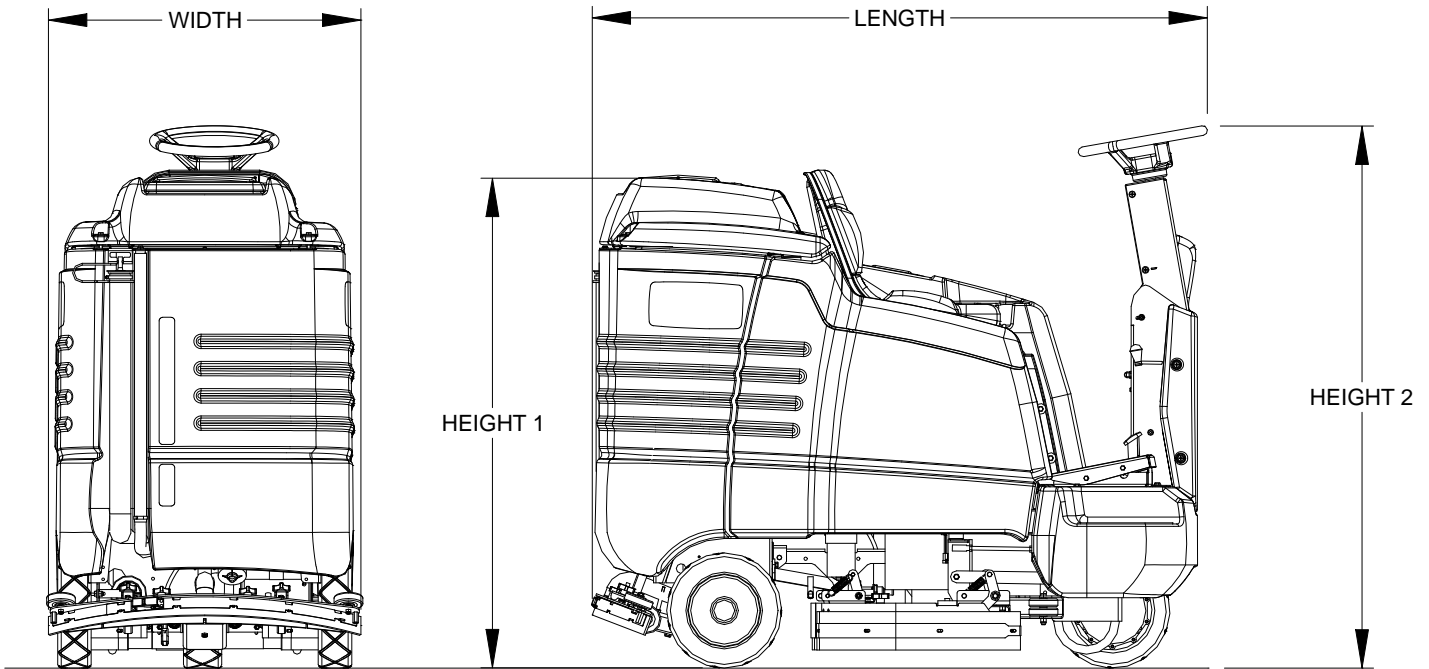

SPECIAL NOTES:

The sound pressure level at the operator's ear was measured to be 72.3 dBA. This was a nearfield, broad-band measurement taken in a typical industrial environment on a tile floor. This appliance contains no possible source of impact noise. The instantaneous sound pressure level is below 63 Pa.

The weighted root mean square acceleration at the operator's arms was measured to be below 2.5m/s^2 . This was a tri-axial, third-octave-band measurement made during normal operation on a composite tile floor. The measurement and related calculations were made in accordance with ANSI S3.34-1986.

HOW THE MACHINE WORKS

The Saber Glide is a battery powered, self-propelled, hard floor scrubber intended for commercial use. The appliance applies a cleaning solution onto a hard floor, scrubs the floor with brushes, and then vacuums the soiled water back into the recovery tank.

The machine's primary systems are the solution system, scrub system, recovery system, and operator control system.

The function of the solution system is to store cleaning solution and deliver it to the scrub system. The solution system consists of the solution tank, strainer, valve and controls. The solution tank stores cleaning solution (water and detergent) until it is delivered to the scrub system. The strainer protects the valve from debris. The valve is a solenoid type valve, which controls the delivery of cleaning solution to the scrub system. The valve automatically prevents solution flow unless the scrub brushes are turned on and the machine is being propelled. The solution control switch controls the amount of cleaning solution delivered to the scrub system by controlling the amount of time the valve is open.

The function of the scrub system is to scrub the floor.

The disk scrub systems consists of two rotary type disk scrub brushes, motors, scrub deck skirt, lift actuator and controls. The brushes scrub the floor as the motors drive the brushes. The brush drive hubs allow the scrub brushes to follow irregularities and changes in the floor without losing contact with the floor. The scrub deck skirts and side squeegees control the cleaning solution on the floor so that the squeegee can pick it up. The one touch switch controls the motors and lift actuator to turn the motors on and lower the deck, or turn the motors off and raise the deck. The brush pressure switch controls the down pressure on the scrub deck.

The function of the recovery system is to vacuum the soiled water back into the recovery tank. The recovery system consists of the squeegee, vacuum motor, filter, recovery tank and controls. The squeegee wipes the dirty solution off the floor as the machine moves forward. The vacuum motor provides suction to draw the dirty solution off the floor and into the recovery tank. The filter protects the vacuum fan from debris and foam. The recovery tank stores the dirty solution.

The float switch in the tank activates the recovery tank full indicator, shuts off the scrub motors and solution flow, raises the scrub deck then squeegee, and shuts off vacuum motor.

The function of the operator control system is to control the direction and speed of the machine. The directional control system consists of the direction/speed control pedal, steering wheel, brake pedal, propel controller, and drive wheel. The direction/speed pedal signals forward or reverse direction and speed. The controller interprets signals from the direction/speed pedal to command the drive wheel to propel or slow the machine. The steering wheel points the drive wheel in the direction desired by the operator. The brake can be used to hold the machine on slopes.

COMPONENTS

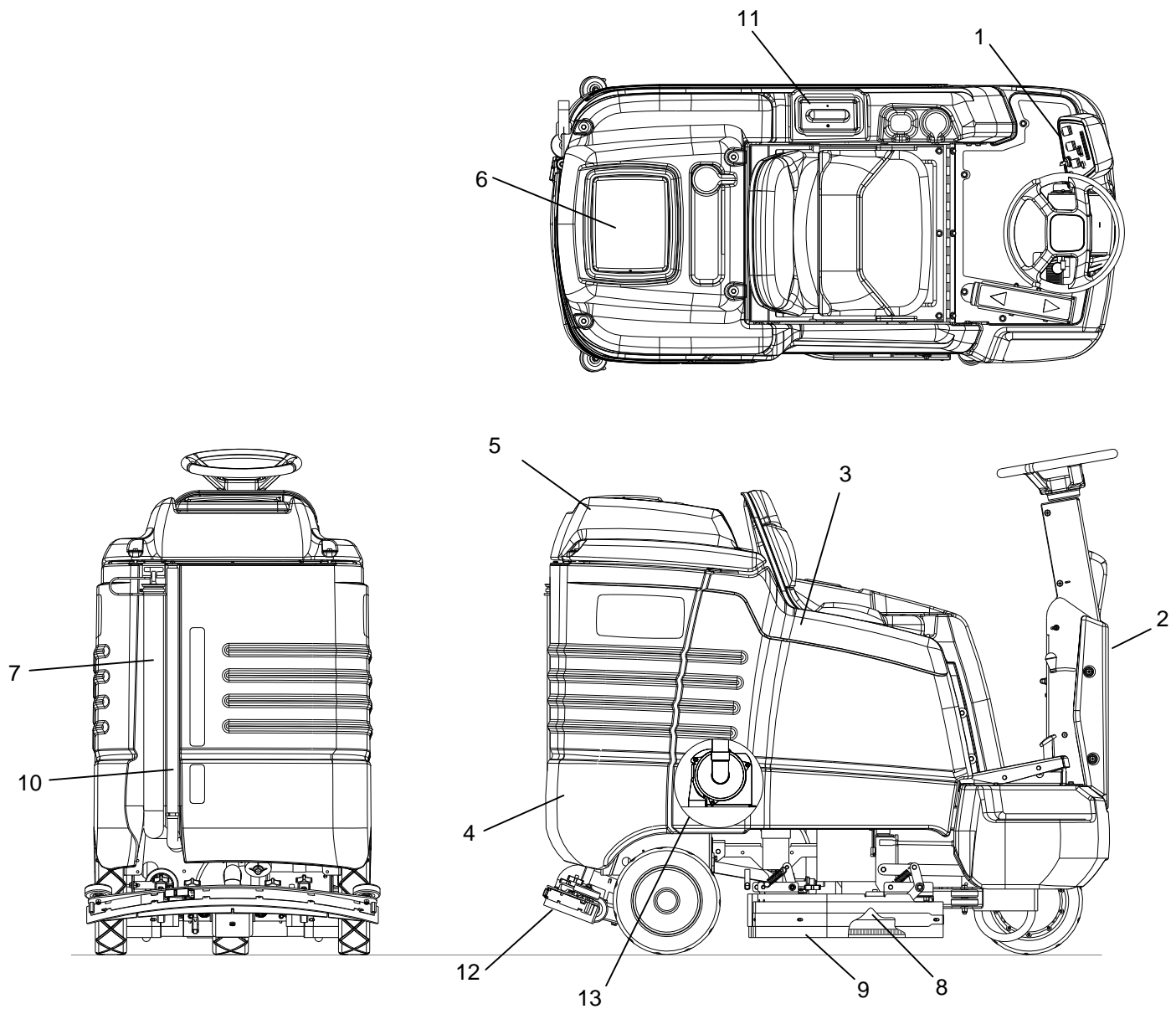

- 1. Control panel
- 2. Front cover
- 3. Side cover
- 4. Tank
- 5. Recovery tank cover
- 6. Recovery tank dome
- 7. Recovery tank drain hose

- 8. Scrub head
- 9. Scrub head side squeegee
- 10. Solution tank drain hose
- 11. Solution tank cover
- 12. Squeegee
- 13. Vacuum motor

CONTROLS

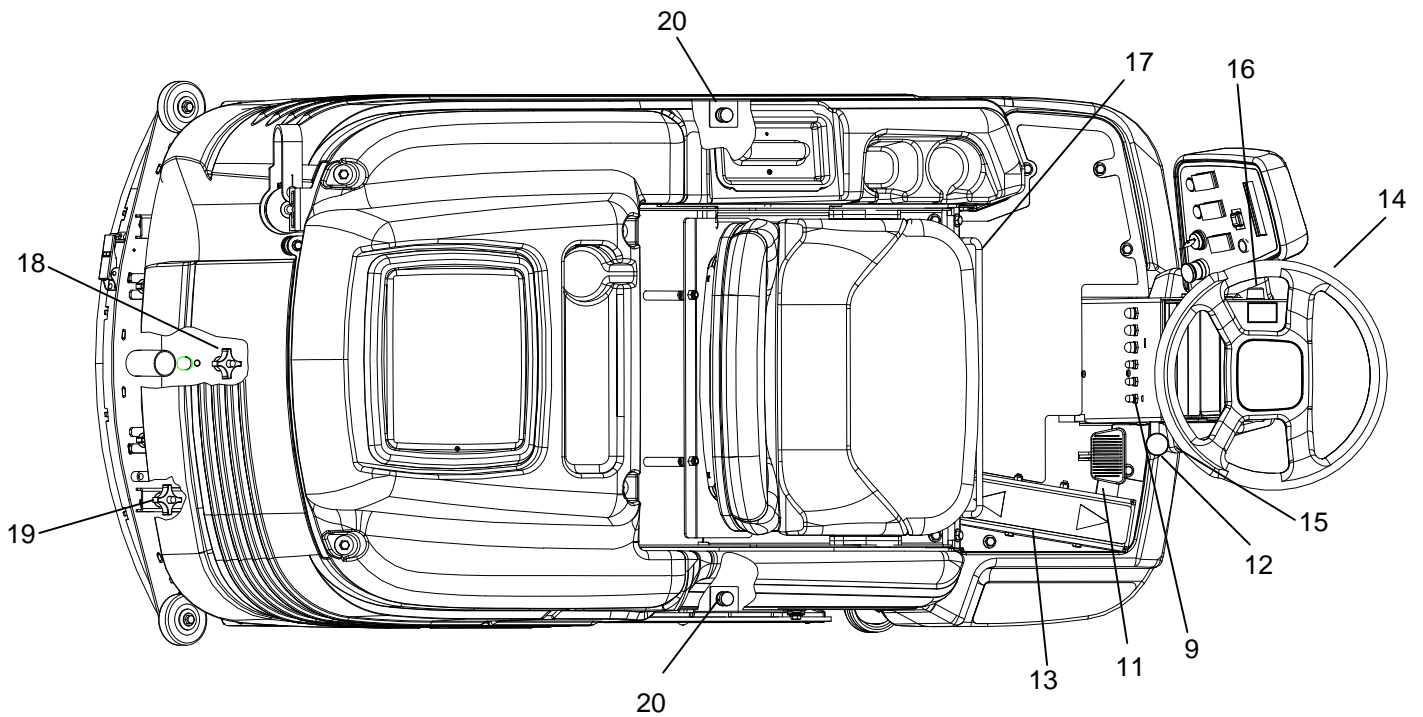
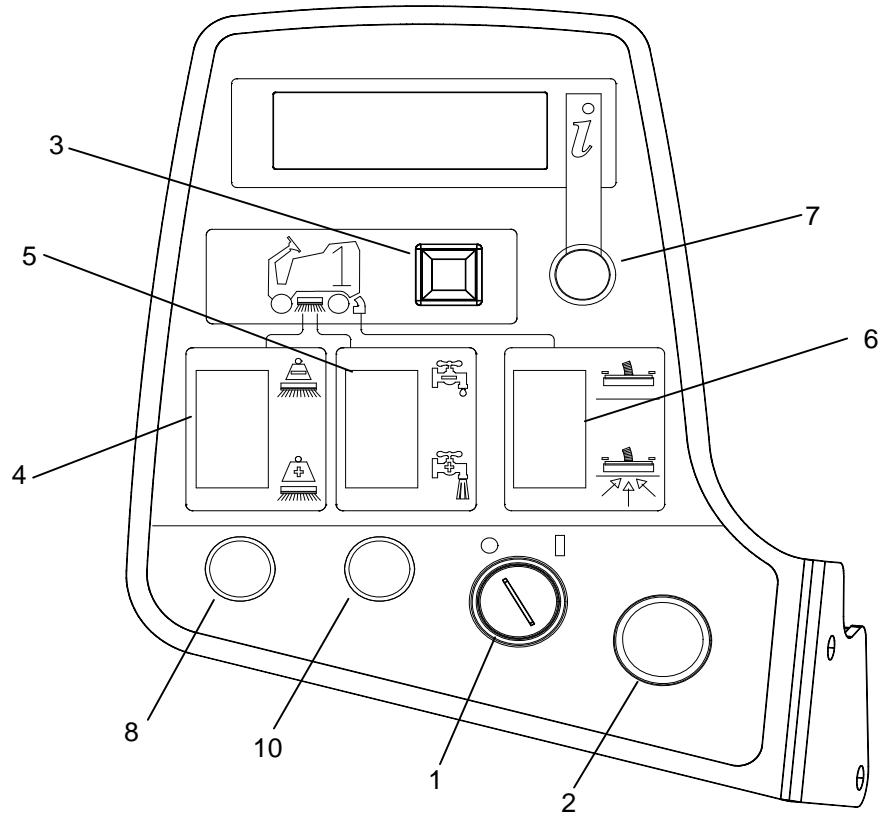

1. Key switch
2. Emergency stop button
3. One touch switch
4. Brush pressure switch
5. Solution control switch
6. Vacuum/squeegee switch
7. Display toggle switch
 - Information Screen 1
 - Information Screen 2
 - Hour meter
 - Fault codes and special icons
 - Battery meter
8. Recycle switch (optional)
9. Recycle indicator light (optional)
10. Headlight switch (optional)
11. Brake pedal
12. Parking brake lever
13. Directional control pedal and speed reduction feature.
14. Steering wheel
15. Steering tilt lever
16. Horn button
17. Seat adjustment grab bar
18. Squeegee camber adjustment knob
19. Squeegee deflection adjustment knob
20. Side squeegee deflection adjustment knob

1. KEY SWITCH

Controls the power for the machine functions. To turn the machine power on, rotate key clockwise. When the key is turned on the battery symbol will flash for 12 seconds while the system runs self-diagnostics and returns scrub deck and squeegee to raised position, if necessary. The controller will not respond to other commands until this routine is complete. To turn the machine power off, rotate key counterclockwise.

INFORMATION DISPLAY

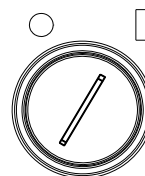

2. EMERGENCY STOP BUTTON

This safety feature is designed to cut all power to the machine at any time. To shut the machine power off, push the Emergency Stop switch. To reset the machine, rotate the switch clockwise.

INFORMATION DISPLAY

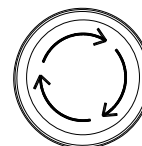

CONTROLS

3. ONE TOUCH SWITCH

This switch controls the scrub brushes and vacuum all in one touch. To start scrubbing, press the one touch switch. The brush drive motors will turn on, the scrub deck will lower to the "light scrub" position, the solution will flow at "two bars" rate, the squeegee will lower and the vacuum will turn on. The information display window will show which functions are operating. If the direction control pedal is in the neutral position for more than two seconds the brushes and solution flow will stop. If the one touch switch is activated without brushes installed, the brush motors will stop, the scrub deck will rise, and the brush pressure indicator will display error code 9000. To stop scrubbing, press the one touch switch. The brush drive motors will turn off, the scrub deck will raise the solution flow will stop, the squeegee will raise after a 15 second delay, and the vacuum motor will turn off. This delay is to clear the vacuum hose of recovered solution.

INFORMATION DISPLAY

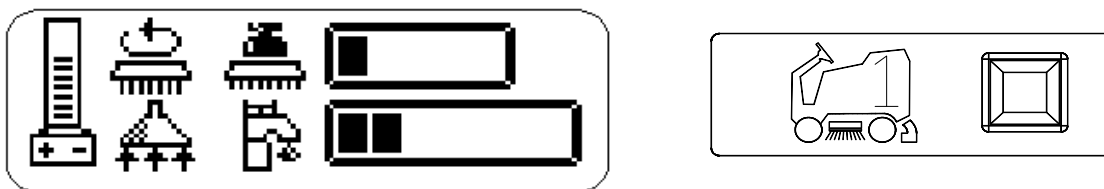

4. BRUSH PRESSURE SWITCH

This switch controls the amount of brush pressure to the floor. There are 5 different pressure settings. To decrease the amount of down pressure, press the top of the brush pressure switch (-). To increase the amount of down pressure, press the bottom of the brush pressure switch (+). The information display screen will show the amount of pressure.

NOTE: Press switch and hold momentarily each time to change brush pressure.

INFORMATION DISPLAY

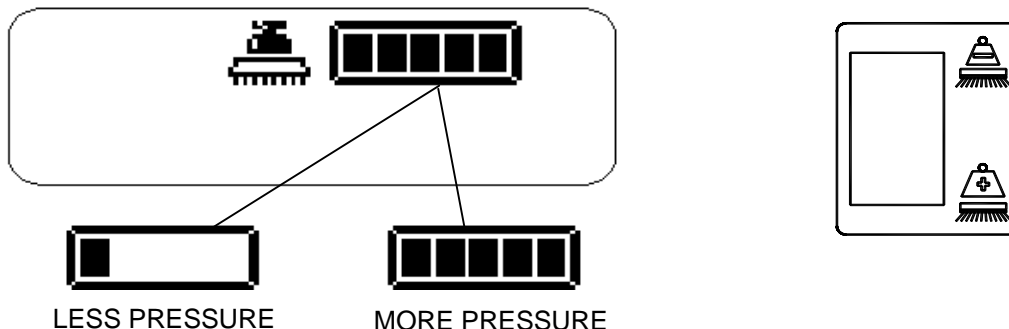

5. SOLUTION CONTROL SWITCH

This switch controls the amount of solution flow to the scrub deck. There are 7 different flow settings. To increase the solution flow, press the solution control switch (+). To decrease solution flow, press the top of the switch (-). If the brush motors are turned off or the direction control pedal is in neutral, the flow is automatically interrupted until the motors are turned on again, or the drive pedal is moved forward or reverse. This feature prevents unintentional draining of the solution tank and allows the operator to adjust the solution flow to the scrub deck without resetting each time the scrubbing operation is interrupted. If recycling option is installed, this switch controls the amount of solution flow to the scrub deck by controlling the speed of the pump.

NOTE: Press switch and hold momentarily each time to change solution flow.

INFORMATION DISPLAY

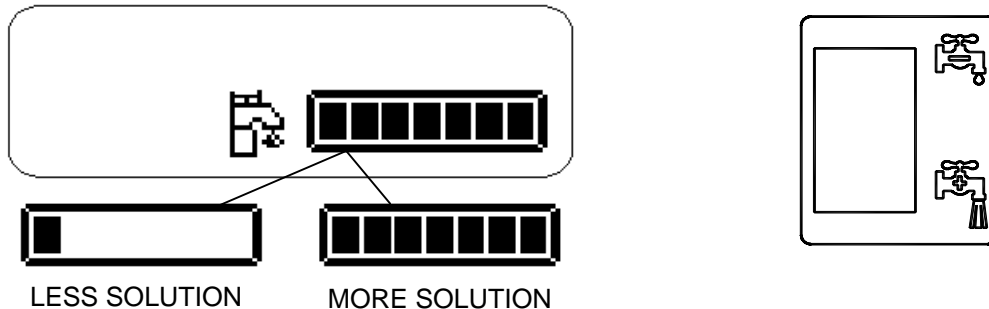

6. VACUUM/SQUEEGEE SWITCH

This switch independently controls the vacuum motor and squeegee position. To start the vacuum motor and lower the squeegee to the floor, press the bottom of the switch. To raise the squeegee and turn off the vacuum motor, press the top of the switch. The squeegee will raise after a 15 second delay, and the vacuum motor will turn off 15 seconds later, in order to clear vacuum hose of recovered solution.

INFORMATION DISPLAY

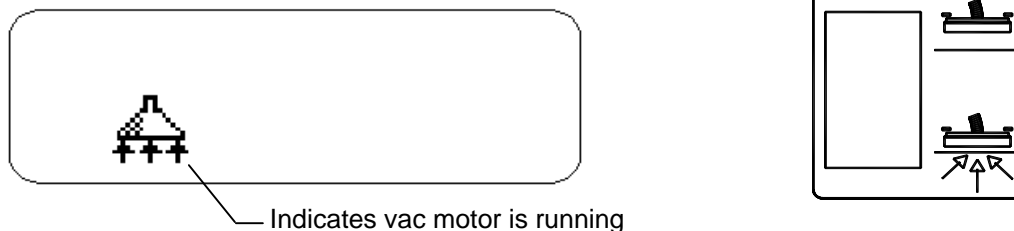

CONTROLS

7. DISPLAY TOGGLE SWITCH

The display toggle switch allows you to change the information display screen. Two screens are available.

- INFORMATION DISPLAY –SCREEN 1

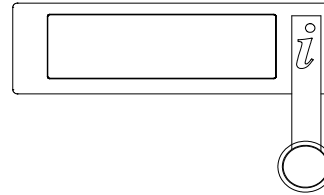
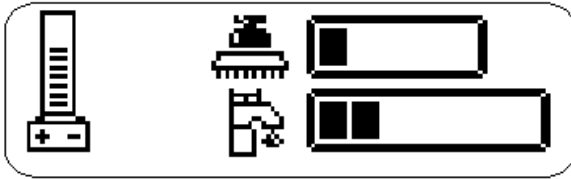

- INFORMATION DISPLAY –SCREEN 2
- The hour meter is viewed on screen 2 of the information display. Hours are displayed for key ON time, brush run time, and traction motor time.

Key ON Hours:
Records the entire time that the key is on.

Brush Run Time:
Records the time spent with the brushes running and gives true brush motor time.

Traction Motor Time:
Records the time spent propelling the machine and gives true traction motor time.

- Fault codes/icon will appear on either display screen when the controller detects a problem within the electrical system. The codes/icons are used to assist users as well as service technicians in identifying and correcting problems. See troubleshooting section for more information on fault codes.

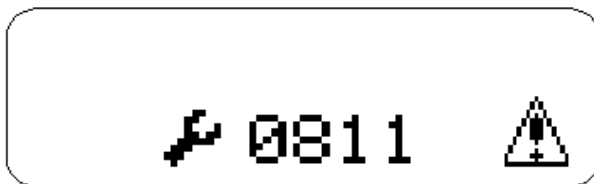

- Icon appears if throttle is depressed when the key is turned on. To correct, lift foot off of throttle. If this does not clear the icon, the throttle may be damaged and should be checked by a qualified service technician.



CONTROLS

- The float switch is located inside the recovery tank. The purpose of the float switch is to notify the user that the recovery tank is full. When the float switch is activated, the scrub brush motors and solution flow will stop, the scrub deck will raise, the squeegee will rise after 60 seconds, and the vacuum motor will turn off 10 seconds later.



- The battery meter can be viewed at the left side of either information screen 1 or information screen 2. The level of battery charge is indicated by the horizontal bars in the battery meter box. When the batteries require charging, the icon will flash and a battery inhibit icon will appear on the right side of either information screen. Scrub and solution functions that are running when the battery inhibit icon appears will be automatically shut off. It is not possible to restart scrub functions while the battery inhibit is displayed. The controller reserves enough battery charge to allow pick-up of residual water and transport back to a charging station.



CONTROLS

8. RECYCLE SWITCH (OPTIONAL)

This switch controls the solution recycle pump. To start recycle pump, press the switch. A green light above the circuit breakers will indicate that pump is on. The solution control switch will control the speed of the pump and therefore the amount of solution flow to the scrub deck. Make sure there is an adequate amount of water in recovery tank before starting recycle pump, and turn off recycle pump when water level reaches filter. To stop the solution recycle pump, press the switch. The pump will stop and the green indicator light will turn off, and the solenoid valve will resume control of solution flow to the scrub deck.



9. RECYCLE INDICATOR LIGHT (OPTIONAL)

This light will turn on when the recycle pump is on, and turn off when the recycle pump is off.



10. HEADLIGHT SWITCH (OPTIONAL)

Turns on optional headlight for improved visibility in low light areas.



11. BRAKE PEDAL

The brake pedal is located on the floor to the right side of the steering column pedestal. The pedal operates the disc brake on the drive wheel. To slow or stop the vehicle, apply pressure to the brake pedal.

12. PARKING BRAKE LEVER

The black knob located on the right side of the steering column pedestal is used to set the parking brake. To set the parking brake, fully depress the brake pedal and push the parking brake knob. To release the parking brake, fully depress the brake pedal. Then release pressure on the brake pedal. The parking brake knob will return it to its' released position.

FOR SAFETY: Before leaving or servicing machine; stop on level surface, set parking brake, turn off machine and remove key.



13. DIRECTIONAL CONTROL PEDAL AND SPEED REDUCTION FEATURE

This pedal controls the direction of travel and the speed of the vehicle. Slowly pressing the front of the pedal causes the machine to travel forward. Pressing the rear of the pedal causes the vehicle to travel in reverse. The vehicle speed can be controlled by varying the pressure on the front or rear of the pedal.

FOR SAFETY: The vehicle can coast for a short distance after releasing the directional pedal. Remove the foot from pedal and use brakes to slow or stop the machine.

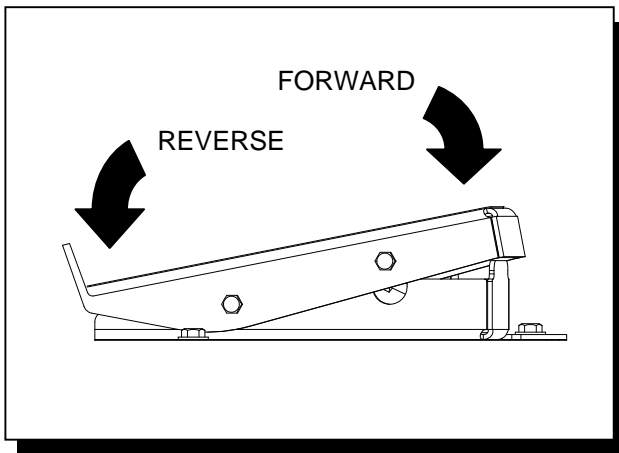

SPEED REDUCTION FEATURE

Maximum speed of machine can be decreased to 80% of maximum by disconnecting wire 3 white from wire 16 white, located between controller and LCD display. Machine is set at 100% speed setting at factory.

CONTROLS

14. STEERING WHEEL

The steering wheel turns the front wheel causing the machine to change direction.

15. STEERING TILT LEVER

The steering tilt lever is located on the right side of the steering wheel. To engage the tilt adjustment, pull on the lever and adjust the steering column to desired position. Release lever and allow it to lock into desired position.

16. HORN BUTTON

The horn button is located on left side of the steering column. The horn is activated by pressing the horn button.

17. SEAT ADJUSTMENT GRAB BAR

The seat adjustment grab bar is located in front of seat at the bottom. While in a standing position, grasp the back of the seat and the seat adjustment grab bar and lift seat into the adjustment slot and lower into one of the locking positions. Adjust the seat to the desired position.

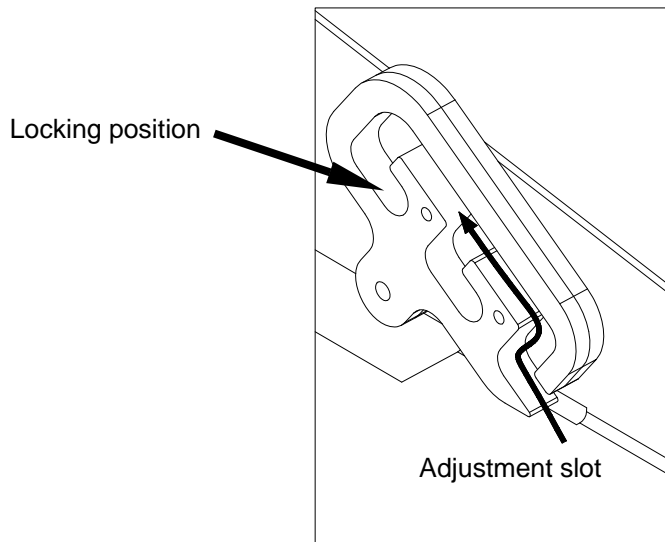

18. SQUEEGEE CAMBER ADJUSTMENT KNOB

The squeegee camber adjustment knob is located at the center of the squeegee at the rear of the machine. (See maintenance section for adjustment).

19. SQUEEGEE DEFLECTION ADJUSTMENT KNOB

The squeegee deflection knob is located at the rear of the machine, on the right side of the squeegee assembly. (See maintenance section for adjustment).

20. SIDE SQUEEGEE DEFLECTION ADJUSTMENT KNOB

Side squeegee adjustment knobs are located above the scrub deck. (See maintenance section for adjustment).

PRE-RUN MACHINE INSPECTION

1. Do a pre-run inspection to find possible problems that could cause poor performance or lost time from breakdown. Follow the same procedure each time to avoid missing steps. Visually check for exterior damage, leaks, damaged or worn tires.
2. Check brushes or pads and drivers for proper installation and wear. Weekly check scrub deck skirts for proper contact with floor. See BRUSHES in MAINTENANCE SECTION.
3. Check squeegee for wear and proper adjustment. See SQUEEGEE ADJUSTMENT in MAINTENANCE SECTION.
4. Check for securely attached drain hose, plug, and caps.
5. Check battery condition, recharge if necessary. See BATTERIES in maintenance section.
6. Check the brakes and steering for proper operation. See BRAKES and STEERING in MAINTENANCE SECTION.

STARTING MACHINE

NOTE: Perform pre-run machine check before operating machine.

FOR SAFETY: Before starting machine, make sure that all safety devices are in place and operating properly.

1. The operator should be in the seat with the right foot on the brake pedal or with the parking brake on. The directional pedal must be in the neutral position to avoid unintentional movement.

NOTE: The Operator must be in position on the seat to activate machine in desired direction.

2. Turn the key switch clockwise to the "ON" position.
3. Release the brake, then press lightly on the directional pedal in the desired direction and drive to the filling area.

FILLING THE MACHINE

FOR SAFETY: Before leaving or servicing machine; stop on level surface, set parking brake, turn off machine and remove key.

1. Set squeegee and scrub deck to up position, set parking brake, and turn off key switch.
2. Remove solution tank cover.



WARNING

Flammable materials can cause an explosion or fire.

Do not use flammable materials in the tanks.

3. The solution tank can be filled to the FULL marking of the fill inlet. Leave room for detergent. The solution tank capacity is 30 gallons (114 liters). The water must not be hotter than 140° (60°C) to prevent damage to the tank. Measure the required amount of chemical into the solution tank after filling with water. Dry chemicals should be thoroughly mixed before being added into solution tank. Commercially available, high alkaline floor cleaners are suitable for use in the solution system.
4. Inspect solution tank cover vent for obstructions. Replace solution tank cover.

SCRUBBING

Plan the scrubbing pattern in advance. The longest track is around the perimeter of the area to be cleaned. For efficient operation, the runs should be the longest possible without turning, stopping, or raising or lowering scrub deck/squeegee.

In order to achieve the best possible results, the area which is to be cleaned should be swept before scrubbing. Large debris, strings and wire must be removed to prevent being caught in brushes or squeegee.

The machine will automatically raise the squeegee slightly when reverse travel is selected. If the machine is allowed to stand in neutral with the scrub deck down for more than 2 seconds, the solutions flow stops and brush motors stop. If either forward or reverse travel is selected, the solution flow will continue in the same setting and the scrub brush motors will continue in their same setting once movement of machine begins. Overlap the brush path and avoid transporting over previously cleaned areas.

INEFFICIENT SCRUBBING PATH

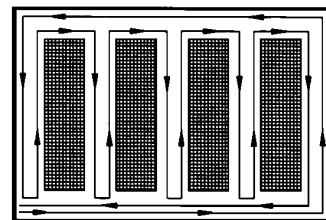

RECOMMENDED SCRUBBING PATH

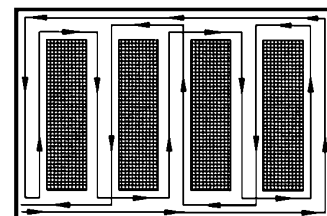

MACHINE OPERATION

TO BEGIN SCRUBBING

⚠ CAUTION When operating the machine around people, pay close attention for unexpected movement. Use extra caution around children.

1. Place right foot on brake pedal or check to make sure parking brake has been set.
2. With directional pedal in neutral turn key switch to "ON".
3. Release brake.
4. Press the directional pedal to travel in the desired direction and steer to the start of the scrub pattern.
5. Press the one-touch switch (#1) on the control panel. The brush motors will start, the scrub deck will lower to the light scrub position, the solution will begin to flow, the squeegee will lower to the floor and the vacuum motors will start.
6. Adjust the speed of the machine, solution flow and scrub brush pressure as necessary.

NOTE: Once solution flow rate is set it is not necessary to shut off solution when stopping scrubbing. Solution flow is automatically shut off when brush motors stop. When brush motors are activated, flow automatically resumes.

⚠ WARNING Flammable liquids and/or reactive metals can cause explosions or fire! Do not pick up.

TO STOP SCRUBBING

1. Press the one-touch switch (#1) on the control panel. The brush motors will stop and the scrub deck will raise to the park position. After 15 seconds, the squeegee will raise, and 15 seconds later the vacuum motor will turn off. This delay is to clear the vacuum hose of recovered solution.
2. Allow directional pedal to return to neutral.
3. Apply brake to stop machine.
4. Turn key switch off.
5. Set parking brake.

FOR SAFETY: Before leaving or servicing machine; stop on level surface, set parking brake, turn off machine and remove key.

EMERGENCY STOP PROCEDURE

1. Turn key switch to off position. If an electrical problem is suspected push in emergency stop button.
2. Release pressure on directional pedal.
3. Apply brakes.

NOTE: Turning the key switch off during normal running operation will stop all motors and actuators. When the key is turned back on the system will automatically return scrub deck and squeegee to raised position.

DOUBLE SCRUB

Floors which are heavily soiled or have thick accumulation of floor finish may not clean sufficiently with one pass. In these cases it will be necessary to double scrub.

To double scrub, make the first pass over the surface being cleaned with the squeegee up, the solution on, and brushes down. This allows the solution to stay in contact with the soil while loosening the surface accumulation with the brushes. Allow time for the first application to stay in contact with floor. Length of time between the first and second pass depends on amount of accumulation and the type of chemical being used. A second scrubbing with the squeegee down and again the solution and brushes on will further loosen soil. The additional application of solution will further assist the difficult cleaning job. Caution should be used when double scrubbing, maintain safe driving speed on wet floors.

EMPTYING AND CLEANING TANKS

RECOVERY TANK

1. Touch the one-touch switch (#1) on the control panel to raise the scrub deck, stop the motors, and solution flow, raise the squeegee and turn off vacuum motors.
2. Park the machine next to a floor drain. Drain hose is on left rear corner of machine.
3. Turn off the key switch and set the machine's parking brake.
4. Unhook the drain hose from retainer. Unscrew T-handle on plug enough to loosen plug and lower hose in direction of drain. Stand behind end of hose. Recovered solution will come out with force. Slowly remove plug from drain hose.
5. Remove recovery tank dome.
6. Flush the recovery tank out with clean water. Repeat until clean water comes out of drain hose. Do not use water hotter than 140° (60°C) to clean the tank. Damage to tank may occur.
7. Replace plug and secure drain hose in bracket.
8. If machine is to be stored, leave recovery tank dome open and drain hose plug off.

SOLUTION TANK

1. Park the machine next to a floor drain. Drain hose is on left rear adjacent to recovery tank drain hose.
 2. Turn off the key switch and set the machine's parking brake.
 3. Unhook the small drain hose from the retainer. Lower hose in direction of the drain.
 4. Remove the solution tank cover.
 5. Flush the solution tank out with clean water and run several gallons of clean water through systems. Do not use water hotter than 140° F (60° C) to clean tank. Damage may occur.
- NOTE:** Never allow solution to remain in tank. Damage to tank, seals and valves could occur.
6. Secure drain hose in bracket.

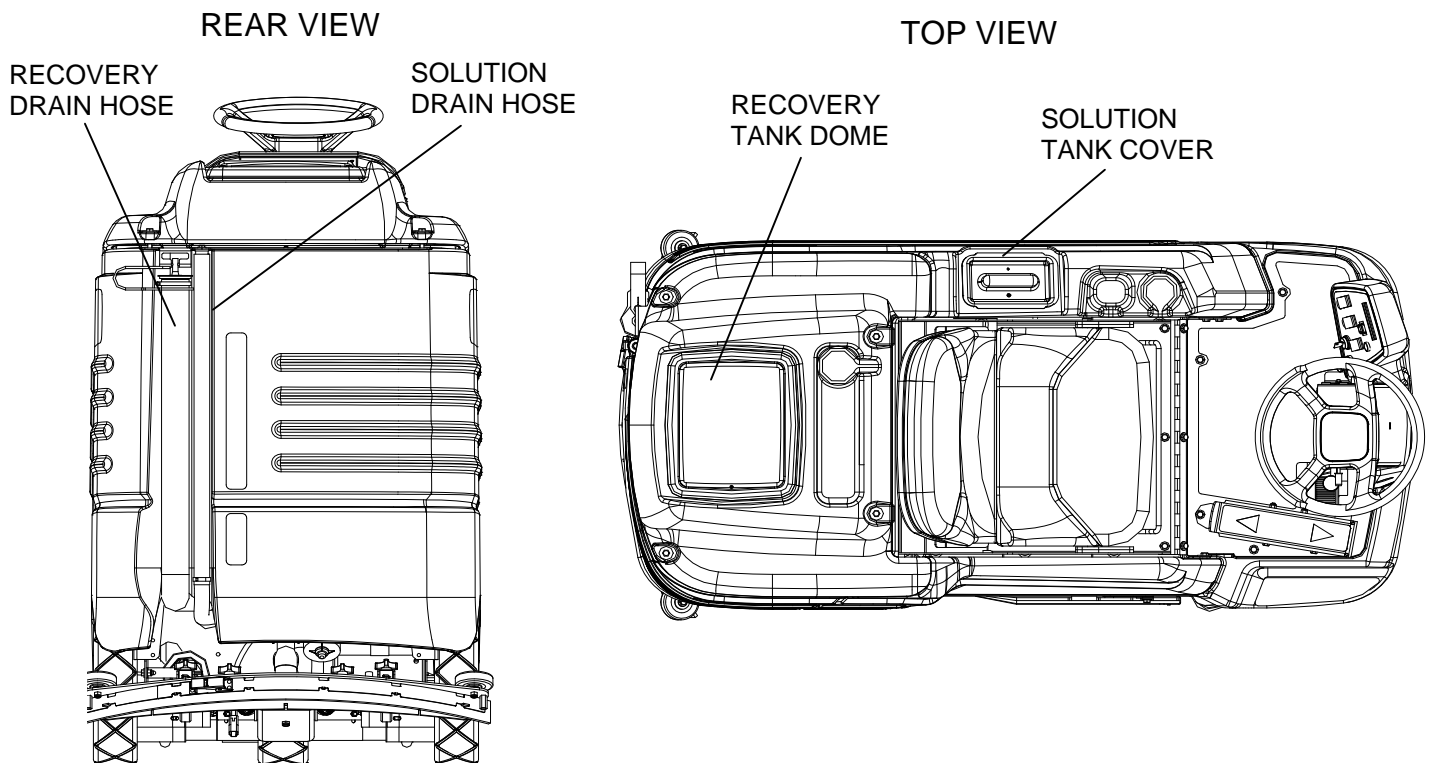

MAINTENANCE

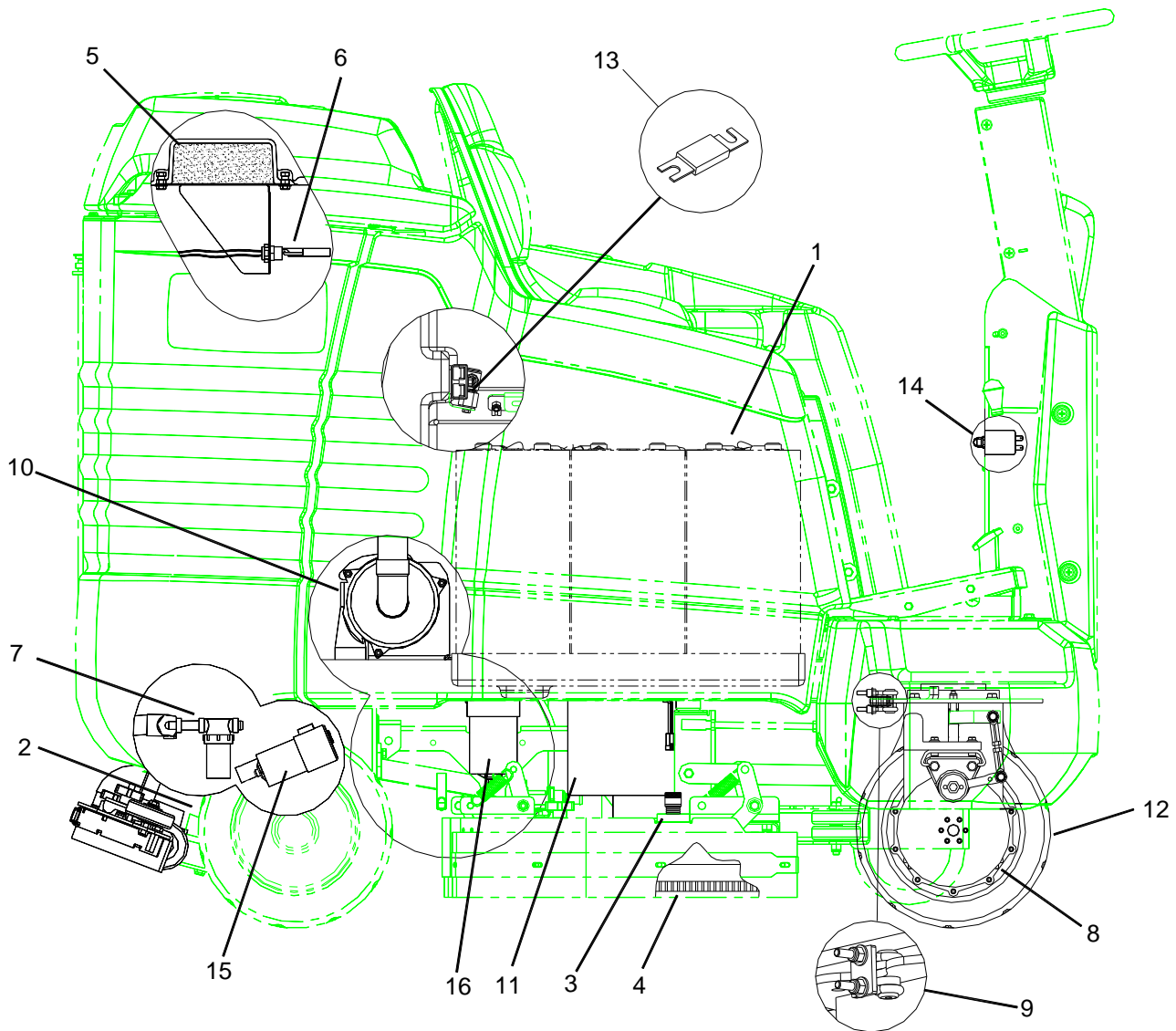

- | | |
|-----------------------------|-----------------------------|
| 1. Batteries | 9. Steering Chain Tensioner |
| 2. Squeegee Adjustment | 10. Vacuum Motor |
| 3. Side Squeegee Adjustment | 11. Brush Motor |
| 4. Scrub Brushes | 12. Traction Motor |
| 5. Vacuum Filter | 13. Fuse |
| 6. Float Switch | 14. Circuit Breaker |
| 7. Solution Strainer | 15. Squeegee Lift Actuator |
| 8. Brake | 16. Scrub Lift Actuator |

1. BATTERIES

The batteries provide the power to operate the machine. The batteries require regular maintenance to keep them operating at peak efficiency.

To get the greatest life from the batteries charge them when their charge level reaches 25% of a full charge. Use a hydrometer to check the charge level.

Do not allow the batteries to remain in a discharged condition for any length of time. Never expose a discharged battery to temperatures below freezing.

Discharged batteries will freeze causing cracked case. Do not operate the machine if the batteries are in poor condition or if they have a charge level below 25%, specific gravity below 1.177.

Keep all metallic objects off the top of the batteries, as they may cause a short circuit. Replace worn or damaged cables and terminals.

Check the electrolyte level in each battery cell before and after charging the batteries. Never add acid to the batteries, use water. Do not allow water level to fall below the battery plates. Portions of plates exposed to air will be destroyed. Do not overfill. Keep plugs firmly in place at all times.

⚠ WARNING When servicing machine, avoid contact with acid.

⚠ WARNING Batteries emit hydrogen gas. Explosion or fire can result. Keep sparks and open flame away. Keep covers open when charging.

⚠ WARNING Wear eye protection and protective clothing when working with batteries.

⚠ WARNING Charge batteries in a well ventilated area.

BATTERY MAINTENANCE

1. When cleaning the batteries, use a solution of baking soda and water. Do not allow the cleaning fluid to enter the battery cells. Electrolyte will be neutralized.
2. Maintain the proper electrolyte level in each battery cell. If a cell should accidentally overflow, clean immediately.
3. Do not add water until the battery is fully charged.
4. Wipe off the top of the batteries at least once a week.
5. Test battery condition with a hydrometer at least once a week.

6. Ensure that all connections are tight and all corrosion removed.
7. Every 4 to 6 months, remove the batteries from the machine and clean the battery cases and battery compartment.

NOTE: Do not take readings immediately after adding water. If the water and acid are not thoroughly mixed, the reading may not be accurate.

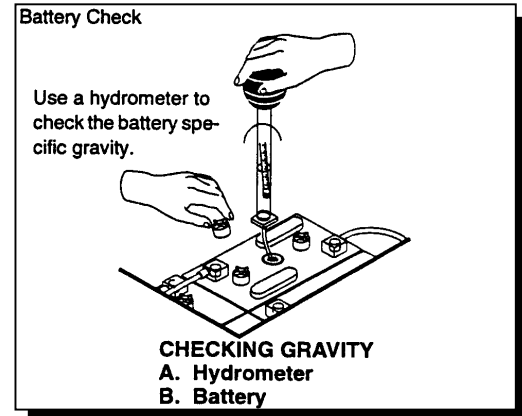

To find the correct specific gravity reading when the temperature of the battery electrolyte is other than 80° F (27° C).

SPECIFIC GRAVITY	BATTERY CONDITION
1.265	100% CHARGED
1.225	75% CHARGED
1.190	50% CHARGED
1.155	25% CHARGED
1.120	DISCHARGED

Add (+) to the specific gravity reading 0.004 (4 points), for each 10° F (6° C) above 80° F (27° C) Subtract (-) from the specific gravity reading 0.004 (4 points), for each 10° F (6° C) below 80° F (27° C).

MAINTENANCE

TO CHARGE BATTERIES

When servicing machine, avoid contact with acid.



WARNING

Batteries emit hydrogen gas. Explosion or fire can result. Keep sparks and open flame away.



WARNING

Keep covers open when charging.

Wear eye protection and protective clothing when working with batteries.



WARNING

Charge batteries in a well ventilated area.



WARNING

1. Stop the machine in a clean, well ventilated area next to the charger.
2. Turn the machine off and set parking brake.

FOR SAFETY: Before leaving or servicing machine, stop on level surface, apply parking brake, turn off machine and remove key.

3. Raise the seat and raise the support arm to lock in place.

Batteries emit hydrogen gas. Explosion or fire can result. Keep sparks and open flame away.



WARNING

Keep covers open when charging.

4. Check the electrolyte level in each battery cell. Before charging, add just enough water to cover up the plates. After recharging has completed, add just enough water to bring up the level to the indicator ring. If water level is too high before charging, normal expansion of the electrolytes may cause overflow, resulting in loss of battery acid balance and damage to the machine.
5. Replace battery caps, and leave them in place while charging.
6. Unplug the battery connector from the machine. Unplug the battery charger from power outlet.

FOR SAFETY: When charging, connect the charger to the batteries before connecting the charger to the AC wall outlet. Never connect the charger to the AC first. Hazardous sparks may result.

7. Use a 36 volt DC charger which will automatically shut off when the batteries are fully charged to charge the six battery pack.

8. Plug the charger into the battery connector. Plug battery charger into power outlet. The charger gauge should indicate that the batteries are charging. If the charger does not automatically start up, verify that charger is plugged into batteries.
9. When the batteries are fully charged, disconnect the charger from the batteries.
10. Connect the batteries to the machine connector.
11. Check the electrolyte level. It should be up to the indicator ring. If necessary, add distilled water.
12. Lower the seat.

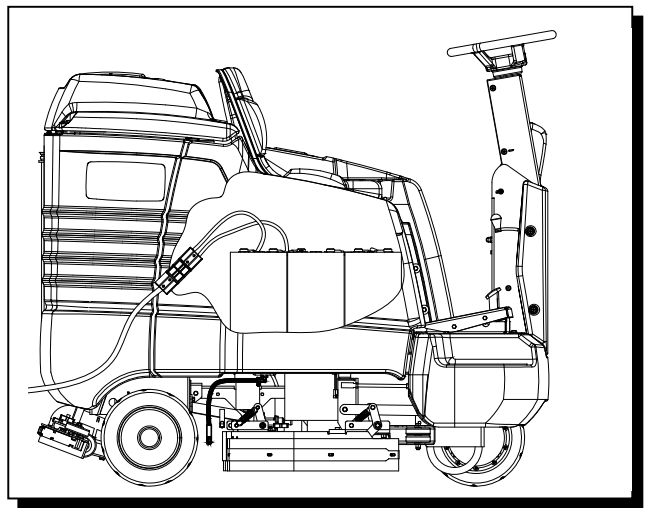

LOW BATTERY SHUT-DOWN

The electronic system is equipped with battery voltage sensors. When the batteries are exhausted to a preset level, the scrubbing system will shut down to protect the batteries from damage, and the battery lockout icon will appear on the display.



TO REMOVE BATTERIES

1. Stop the machine in a clean area next to the charger.
2. Turn off machine and set parking brake.

FOR SAFETY: Before leaving or servicing machine, stop on level surface, apply parking brake, turn off machine and remove key.

3. Raise the seat plate.
4. Remove side cover.
5. Disconnect battery pack from the machine.
6. Use the proper size open end wrench to disconnect main ground wire first and secure cable terminal away from batteries.
7. Disconnect main positive lead and secure cable terminal away from battery/batteries.
8. Loosen both terminals on each jumper cable and remove one at a time.
9. Prepare a suitable battery site to place batteries.
10. Attach suitable battery lifting device and lift batteries from the machine.

CAUTION

Batteries are a potential environmental hazard. Consult your battery supplier for safe disposal methods.

TO REPLACE BATTERIES

1. Refer to diagram. Place batteries in battery compartment.
2. Connect all jumper cables positive to negative to the six batteries.
3. Connect the positive cable to battery in the position shown.
4. Connect negative cable to battery in the position shown.

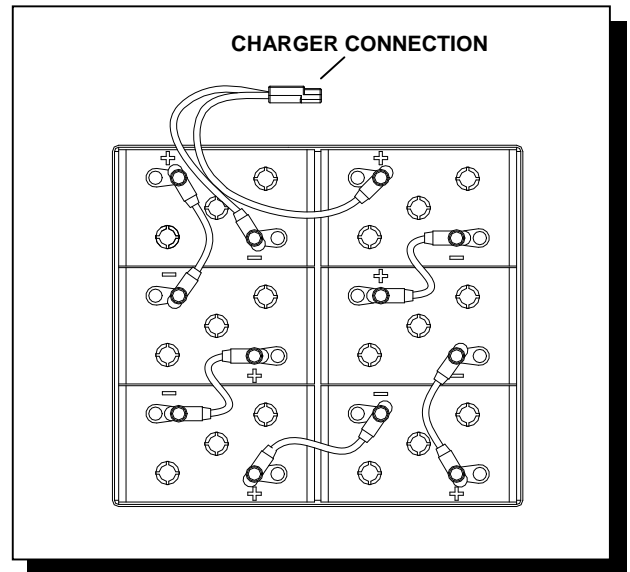

MAINTENANCE

2. SQUEEGEE ADJUSTMENT

Adjusting the squeegee is a two-part process. First, the squeegee tool must have correct pitch in order for the squeegee blade to have the same deflection at each tip as well as the center. The pitch adjustment is facilitated by the use of a spirit level mounted on the squeegee tool. The second adjustment is the amount of deflection or down pressure on the squeegee.

TO ADJUST SQUEEGEE PITCH

1. Choose a smooth, level surface. Turn on the key switch, release the machine parking brake, lower the squeegee and drive forward at least 2 feet (60 cm).
2. With the squeegee down, stop the machine and set the parking brake. Do not allow the machine to roll back.

FOR SAFETY: Before leaving or servicing machine; stop on level surface, turn off machine and remove key.

3. Determine the differences, if any, in deflection of the squeegee blade between each end and the middle. Proper adjustment is obtained when deflection is equal all the way across tool. This should correspond to the bubble being in the middle position of the spirit level.
4. To decrease the deflection of the squeegee blade at the ends, turn knob on squeegee trailing arm clockwise. To increase the deflection at the ends of the squeegee assembly, turn knob counter clockwise.
5. Again check the deflection of the squeegee blades. Repeat steps 1 through 4 until the deflection is equal across the entire rear squeegee blade.

TO ADJUST SQUEEGEE DEFLECTION

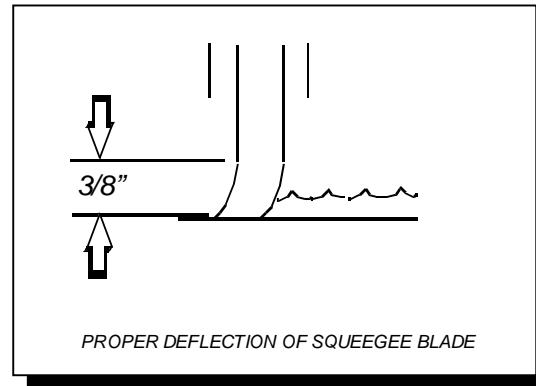

1. Choose a smooth, level surface. Lower the squeegee and drive forward at least 2 feet.
2. With the squeegee down, stop the machine and set the parking brake. Do not allow the machine to roll back.

FOR SAFETY: Before leaving or servicing machine; stop on level surface, turn off machine and remove key.

3. Observe the amount of squeegee deflection. It should deflect 3/8in (9.5 mm) across the entire width of the squeegee.
4. To adjust the squeegee deflection, loosen knob on the squeegee slide bar.
5. Sliding bar to left increases deflection. Sliding bar to right decreases deflection.
6. Tighten knob on squeegee slide bar.
7. Turn on the key switch, release the machine parking brake. Raise, then lower squeegee assembly by pressing the vacuum switch. Drive forward at least 2 feet.
8. Repeat steps 2 through 7 until deflection of 3/8 in. (9.5 mm) is reached.

TO REPLACE OR ROTATE REAR SQUEEGEE BLADES

1. With the squeegee in the up position, turn off the key switch and set the parking brake.

FOR SAFETY: Before leaving or servicing machine; stop on level surface, turn off machine and remove key.

2. Unlock and pull open latch on rear of squeegee tool.
3. Remove blade retainer straps from squeegee tool.
4. Remove squeegee blade from locating pins on squeegee tool and rotate to new position or replace as required.
5. Install blade on locating pins of squeegee tool.
6. Install squeegee retainer straps.
7. Fasten and lock latch. Latch is adjustable. Adjust latch only tight enough to take up slack in retaining strap.

NOTE: Changing of squeegee blades does not always necessitate a readjustment. Refer to section on adjusting squeegee.

TO REMOVE SQUEEGEE ASSEMBLY

1. With the squeegee in the up position, turn off the key switch and set the parking brake.

FOR SAFETY: Before leaving or servicing machine; stop on level surface, turn off machine and remove key.

2. Disconnect vacuum hose and loosen the two squeegee retaining knobs.
3. Pull squeegee assembly rearward from the lifting carrier.
4. With squeegee assembly on bench inspect or repair as necessary.
5. To reinstall, align squeegee assembly to lift carrier. Push forward until squeegee is fully engaged.
6. Tighten knobs.
7. Attach vacuum hose.

TO REPLACE OR ROTATE FRONT SQUEEGEE BLADES

1. With squeegee assembly on bench, loosen retaining bolt and locking nut on the left side of the retaining strap.
2. Remove front retainer strap.
3. Remove squeegee blade from locating pins on squeegee tool and rotate to new position or replace as required.
4. Install blade on locating pins of squeegee tool.
5. Replace front retainer strap.
6. Secure strap by tightening retaining bolt and locking nut on retainer strap.

NOTE: Changing of squeegee blades does not always necessitate a readjustment. Refer to section on adjusting squeegee.

MAINTENANCE

3. SIDE SQUEEGEE ADJUSTMENT TO REPLACE OR ROTATE SIDE SQUEEGEE BLADES

1. Loosen the locking knob and pivot the side squeegee out as if to expose the brush.
2. Loosen and remove the three nuts and bolts securing squeegee blades.
3. Remove the retaining strap and squeegee blade and rotate or replace squeegee blade.
4. Install blade and retaining strap on locating pin and reinstall three bolts and nuts.
5. Tighten nuts. Do not over tighten nuts as this will damage the retaining strap and deform the squeegee blade.
6. Pivot the side squeegee back into place and tighten the locking knob.

ADJUSTING THE SIDE SQUEEGEE DEFLECTION

Side squeegee should deflect approximately 3/8 in. when in use. If the blade is under curled it will skip low spots and leave puddles. If the blade is over curled or worn it will smear water and leave stripes and streaks.

1. Choose a smooth level surface. Lower the scrub deck to the floor and drive forward slowly while observing the curl and squeegee performance.
2. To increase the curl, turn the deflection adjustment knob counter clockwise.
3. To decrease the curl, turn the deflection adjustment knob clockwise.

4. SCRUB BRUSHES

There are five different types of brushes available to cover applications from cleaning heavily soiled floors to polishing. A pad driver is also available to take advantage of the many cleaning pads on the market and further add to the flexibility of the machine.

Please refer to the following to assist in selecting the proper brush or pad for the work at hand.

UNCOATED FLOORS

Aggressive Grit is a nylon fiber impregnated with silicone carbide grit. It grinds away stain, soil, and removes surface material.

Mild Grit is a less aggressive silicone carbide grit suitable for cleaning medium soil conditions. Advantages are faster ground speed than nylon bristles on light solid applications.

Nylon is a general-purpose scrub brush with stiff bristles.

Polypropylene works well for maintaining concrete, wood and tile floors.

FINISHED FLOORS

Nylon bristles are used in a variety of applications on coated or uncoated surfaces.

Polypropylene bristles work on a variety of floor surfaces. Does not soften in water

White Pads (Polishing) are used for dry polishing to achieve a high-gloss appearance, or surface washing on highly polished or burnished floors.

Red Pads (Buffing) are used for light-duty scrubbing. When used with a mild detergent they will provide surface cleaning without removing the finish.

Blue Pads (Scrubbing) are used for heavy-duty scrubbing and light stripping. The blue pads remove less finish than brown stripping pads, yet will remove black marks, stains and dirt.

Brown Pads (Stripping) are used for easy and complete removal of old floor waxes/finishes. They will quickly remove ground in dirt, black heel marks, and spills. When used with the proper stripper, this pad leaves the floor clean and ready for finishing.

REPLACING OR INSTALLING SCRUB BRUSHES

The scrub brushes should be checked before each days work for wire, string, wear, or damage. The scrub brushes should be replaced if brush bristles are missing or if shorter than 5/8 inch.

NOTE: For uniform scrubbing, scrub brushes must be replaced as a set.

1. With the scrub deck up, turn off the machine and set the parking brake.
2. Loosen side squeegee locking knob, and pivot side squeegee away from scrub deck.
3. Locate release lever on top of brush or pad driver. With finger rotate release lever against spring pressure counter clockwise. Brush/pad driver will release and drop down.
4. To reinstall, center the cut out of the release lever plate on brush/pad driver to be installed under the brush drive hub.
5. Raise brush/pad drive up until assembly contacts brush hub. Rotate slightly until drive engages release lever plate.
6. While holding upward pressure, rotate brush/pad driver assembly clockwise. When fully engaged, release lever plate will rotate under spring pressure to lock assembly.

NOTE: Check that release plate is completely closed and pad/brush is securely attached. Damage to driver or brush could occur.

7. Repeat the procedure for the opposite side of the machine.

MAINTENANCE

5. VACUUM FILTER

The vacuum filter is located inside the recovery tank. The vacuum filter prevents debris from entering the vacuum motor. Daily remove and clean filter of any debris for maximum airflow.

6. FLOAT SWITCH

The float switch is located inside the recovery tank. The purpose of the float switch is to notify the user that the recovery tank is full. When the float switch is activated, the scrub brush motors and solution flow will stop, the scrub deck will raise, the squeegee will rise after 60 seconds, and the vacuum motor will turn off 10 seconds later.



Icon appears on information screen 1 when float switch is activated.

7. SOLUTION STRAINER

The solution strainer is located behind the right rear wheel of the Glide. The solution strainer protects the solenoid valve from debris. If there is little or no solution flow to the ground, check the strainer for debris. Drain the solution tank and clean the solution strainer. To remove the strainer, turn the bottom part of the strainer counterclockwise until the bottom is separated. Clean out the debris from the wire mesh and re-assemble. Make sure the O-ring gasket is in place when re-assembled.

8. BRAKE

(Refer to Brake Group in the Parts section of the manual).

The brake pedal and parking brake operate the self-centering front wheel disc brake. The disc and caliper should be inspected every 200 hours of operation for cracks and disc wear. The brake should be adjusted so that the disc pads are as close to the disc as possible, without causing brakes to drag.

BRAKE ADJUSTMENT

FOR SAFETY: Before leaving or servicing machine, stop on a level surface, turn off machine and remove key.

1. Disconnect batteries from machine.
2. Turn the steering wheel fully to the left.
3. Locate the brake adjustment screw on the brake caliper.
4. Loosen the lock nut.
5. Turn adjustment screw in until finger tight, then back off 1/8 turn.
6. Hold adjustment screw and tighten lock nut.

9. STEERING CHAIN TENSIONER

(Refer to Steering Group in parts section of manual).

The steering chain transfers power from the steering shaft to the drive wheel, controlling steering response. Check the chain condition and tension every 200 hours of operation. Proper chain tension is important to maintain steering response. The chain should deflect 1/16 in. Use a light spray lube if needed.

STEERING CHAIN TENSIONER ADJUSTMENT

1. Locate chain tensioner bolts.
2. To increase tension, tighten lock nuts retaining chain tension plate.
3. To decrease tension, loosen lock nuts retaining chain tension plate.

10. VACUUM MOTOR

(Refer to the Vacuum Group in the parts section of manual)

⚠ WARNING

Do not use a pressure washer to clean around the vacuum motors. Use tap pressure only. Care must be taken so that water is not directed into vacuum motor air intakes.

CHANGING VACUUM MOTOR

1. Remove side cover.
2. Disconnect electrical connector to the vacuum motor.
3. Loosen clamp and disconnect hose from vacuum intake.
4. Loosen clamp and disconnect vacuum muffler from vacuum outlet.
5. Remove vacuum motor mounting bracket bolts, which are located under frame.
6. Remove vacuum motor from mounting bracket assembly.
7. Reverse steps to install.

Vacuum Motor Carbon Brushes Replacement (Windsor)

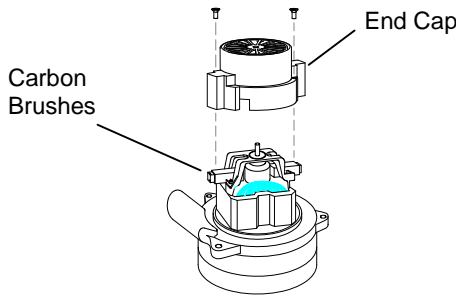

If armature commutator is grooved, extremely pitted or not concentric, the motor will need to be replaced or sent to a qualified service center.

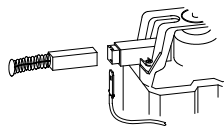

Important:

These brushes wear quicker as the length shortens due to increased heat. Spring inside brush housing will damage motor if brushes are allowed to wear away completely.

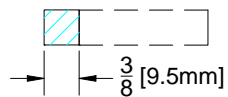

Periodically check the length of the carbon brushes. Replace both carbon brushes when either is less than 3/8" (9.5mm) long.

Vacuum Motor Carbon Brushes Replacement (Ametek)

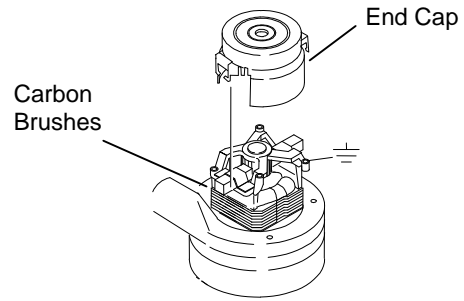

If armature commutator is grooved, extremely pitted or not concentric, the motor will need to be replaced or sent to a qualified service center.

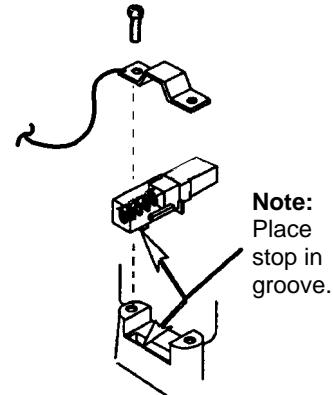

Important:

These brushes wear quicker as the length shortens due to increased heat. Spring inside brush housing will damage motor if brushes are allowed to wear away completely.

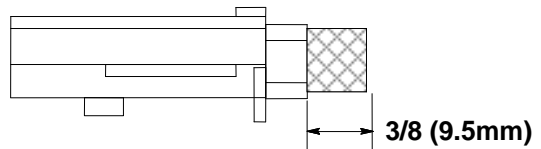

Periodically check the length of the carbon brushes. Replace both carbon brushes when either is less than 3/8" (9.5mm) long.

MAINTENANCE

11. BRUSH MOTOR

(Refer to Brush Motor Group in parts section of manual).

WARNING

Do not use a pressure washer to clean around the brush motors. Use tap pressure only.

CHANGING BRUSH MOTORS

1. With the scrub deck in the stored position, disconnect brush motor wiring connector from harness.
2. Loosen side squeegee locking knob, and pivot side squeegee away from scrub deck to access and remove scrub brushes or pad drivers.
3. Remove retaining bolt, lock washer, flat washer and star drive from brush motor shaft.
4. Remove 4 brush motor mounting bolts located under scrub deck.
5. Remove brush motor. If needed, lower scrub deck for more clearance.
6. Reverse steps to install.

BRUSH MOTOR CARBON BRUSH REPLACEMENT

1. Scribe alignment marks on motor barrel to motor cap and motor barrel to motor frame.
2. Remove end cap from motor.
NOTE: Motors contain two wave washers in cap. Do not lose these.
3. Release brush from spring tension. Remove screw connecting brush wire lead to brush holder. Clean brush holder to insure free movement.
4. Install new brush and reinstall connecting screw and lead.
5. When all new brushes are installed. Place all in retracted position, held into brush holder by spring tension.
6. Carefully place end cap onto bearing on motor shaft.
NOTE: On motors use care to assure wave washer alignment.
7. With end cap in partially installed position, release all brushes to contact position with motor commutator.
NOTE: Failure to insure all brushes are released will result in motor failure.
8. Reset end cap and realign with scribe marks on motor barrel.
9. Maintain alignment between motor barrel base and cap, and between motor barrel and motor frame. Reinstall the two attach bolts from cap into base

12. TRACTION MOTOR

⚠ WARNING Do not use a pressure washer to clean around the brush motors. Use tap pressure only.

TRACTION MOTOR CARBON BRUSH REPLACEMENT

FOR SAFETY: Before leaving or servicing machine, stop on a level surface, turn off machine and remove key.

1. Disconnect batteries from machine.
2. Turn the steering wheel fully to the right.
3. Disconnect the electrical connection to the traction motor (keeping note of which wire is positive and negative). Use a wrench to hold locking nuts while loosening connector nut to prevent threaded stud from turning.
4. Scribe alignment mark on motor barrel to motor cap.
5. Remove end cap from motor.
NOTE: Motors contain two wave washers in cap. Do not lose these.
6. Release brush from spring tension. Remove screw connecting brush wire lead to brush holder. Clean brush holder to insure free movement.
7. Install new brush and reinstall connecting screw and lead.
8. When all new brushes are installed. Place all in retracted position, held into brush holder by spring tension.
9. Carefully place end cap onto bearing on motor shaft.
NOTE: On motors use care to assure wave washer alignment.
10. With cap end in partially installed position, release all brushes to contact position with motor commutator.
NOTE: Failure to insure all brushes are released will result in motor failure).
11. Maintain alignment between motor barrel base and cap. Reinstall the two attach bolts from cap into base.

13. FUSE

The fuse is a one-time circuit protection device designed to stop the flow of electrical current in the event of an electrical overload. If fuse is blown, it must be replaced.

The fuse is located inside the battery compartment.

14. CIRCUIT BREAKERS

Interrupt the flow of power in the event of an electrical overload. When a circuit breaker is tripped, reset it by pressing the exposed button. If a circuit breaker continues to trip, the cause of the electrical overload should be found and corrected.

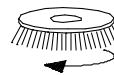

25 Amp. Protects the left scrub brush motor.

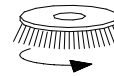

25 Amp. Protects the right scrub brush motor.

MAINTENANCE

15. SQUEEGEE ACTUATOR REMOVAL/REPLACEMENT

FOR SAFETY: Before leaving or servicing machine, stop on a level surface, turn off machine and set parking brake.

1. Remove squeegee to gain access to lift system.
2. Lower squeegee lift linkage, if possible, by pressing bottom of vacuum/squeegee switch and turn key to the off position.
3. Remove lower clevis pin by removing rue ring and washer from clevis pin, then pull pin out from squeegee lift bracket and actuator.
4. Remove upper clevis pin (ball detent type) by pulling on it's ring (located on left side), then pull it out from the frame and actuator. Pull actuator down to remove from the machine, make sure not to allow actuator barrel position to move.
5. Disconnect actuator from wire harness.
6. Reverse steps to install.

SQUEEGEE ACTUATOR ADJUSTMENT

The actuator will need to be adjusted when replaced. The actuator needs to be set such that it does not bind against itself in the raised/retracted position, and does not bind against the axle in the lowered/extended position.

To adjust the actuator:

1. While holding actuator barrel to prevent it from spinning, apply power to the actuator such that it is fully extended. Positive power to white wire, and negative/ground to black. Limit switch within actuator will stop it.
2. Turn barrel out one or more full turns to assure that when it is retracted it will not bind against itself.
3. While holding actuator barrel to prevent it from spinning, apply power to the actuator such that it is fully retracted. Positive power to black wire, and negative/ground to white wire. Limit switch within actuator will stop it.
4. With actuator fully retracted, turn barrel in until it touches the base of the threaded shaft.
5. At the bottomed out position, turn the barrel out **1 full turn**, then enough to allow connection to lift linkage.
6. Connect actuator to lift linkage and check that in the raised/retracted position it does not bind against itself, and in the lowered/extended position does not bind against the axle
7. If further adjustment is needed, disconnect the actuator from squeegee lift linkage and turn the barrel one half-turn at a time in to eliminate binding against axle, or out to eliminate binding against itself.

16. SCRUB DECK ACTUATOR REMOVAL/REPLACEMENT

FOR SAFETY: Before leaving or servicing machine, stop on a level surface, turn off machine and set parking brake.

1. Lower scrub deck, if possible, by pressing one-touch switch and turn key to off position.
2. Remove lower clevis pin by removing rue ring from clevis pin, then pull pin out from scrub deck lift bracket and actuator.
3. Remove upper clevis pin (ball detent type) by pulling on it's ring (located on left side), then pull it out from the frame and actuator. Remove from the machine, make sure not to allow actuator barrel position to move.
4. Disconnect actuator from wire harness.
5. Reverse steps to install.

SCRUB DECK ACTUATOR ADJUSTMENT

The actuator will need to be adjusted when replaced. The actuator needs to be set such that the scrub deck stops barely touch the rubber bumpers on the frame in the raised/retracted position.

To adjust the actuator:

1. While holding actuator barrel to prevent it from spinning, apply power to the actuator such that it is fully extended. Positive power to white wire, and negative/ground to black. Limit switch within actuator will stop it.
2. Turn barrel out one or more full turns to assure that when it is retracted it will not bind against itself.
3. While holding actuator barrel to prevent it from spinning, apply power to the actuator such that it is fully retracted. Positive power to black wire, and negative/ground to white wire. Limit switch within actuator will stop it.
4. With actuator fully retracted, turn barrel in until it touches the base of the threaded shaft.
5. At the bottomed out position, turn the barrel out **3 full turns**, then enough to allow connection to lift linkage.
6. Connect actuator to lift linkage and check that in the raised/retracted position the stops on the scrub deck barely touch the rubber bumpers on the frame.

NOTE: If further adjustment is needed, disconnect the actuator from scrub deck lift linkage and turn the barrel one half-turn at a time in to make scrub deck stops closer to bumpers, or out to eliminate excessive pressure against bumpers.

TRANSPORTING MACHINE

TOWING OR PUSHING MACHINE

The machine may be towed for short distances at speeds not to exceed 5 mph. Be careful to avoid damaging machine. Attach towing device at tie down point. The machine may be pushed by hand from the rear.

NOTE: To avoid damage caused by regenerative voltage, disconnect traction motor before towing or pushing machine.

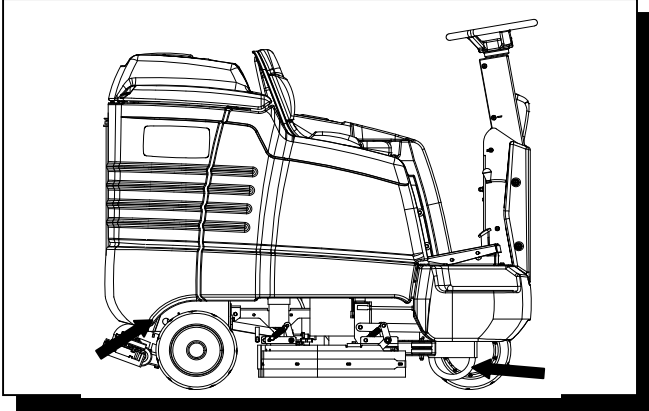

MACHINE TIE-DOWNS

There are two tie points located at the rear, side of the machine frame and two at the front corners. Tie-down devices must be of the proper type and strength. The combined strength of all tie-downs must be strong enough to lift two times the weight of the machine. Tie-downs must be positioned to prevent the machine from moving forward, backward, or either side to side. Use all four corners of the machine with the tie-downs running out opposite directions. Tie-downs must be attached to the transporting vehicle securely.

PREPARATION FOR TRANSPORTING

Remove squeegee tool to eliminate interference with tie-downs.

Scrub head must be in the up position before loading.

NOTE: When transporting the machine on a trailer or in a truck, in addition to using tie-downs, be sure to set the parking brake, and block the tires to prevent the machine from rolling.

MACHINE JACKING

The machine may be jacked up for service or inspection by using the specified jack locations. Always block the tires when jacking up the machine.

FOR SAFETY: Before leaving or servicing machine; Stop on level surface, set parking brake, turn off machine and remove key.

The rear jack points are the frame just behind the rear wheels. Remove the squeegee tool before jacking.

NOTE: See Squeegee Tool Removal in Maintenance Section.

The front jacking point is the front bumper.

TO JACK UP MACHINE

1. Empty the recovery and solution tank.
2. Turn the key switch off and set the parking brake.

FOR SAFETY: Before leaving or servicing machine; Stop on level surface, set parking brake, turn off machine and remove key.

3. Block the tires that are not being raised to prevent the machine from rolling.

FOR SAFETY: When servicing machine, block machine tires before raising machine.

4. Using a jack of adequate capacity. Raise the machine using the designated jack points.

FOR SAFETY: When servicing machine, use hoist or jack of adequate capacity, jack machine at designated jack locations only. Block machine with jack stands when raised.

5. When machine is raised, use jack stands at the designated jack locations. Support the front of the machine by placing jack stands or solid wood blocks under the U-shaped stabilizer bars.

FOR SAFETY: Block machine at designated jack locations with jack stands when raised.

6. Slowly lower the machine onto the jack stands.
7. Be sure that the machine is secure.
8. Service or inspect the machine as required.
9. When finished working on the machine, raise the machine off the jack stands.
10. Remove the jack stands.
11. Lower the machine to the floor. Block wheels as they are lowered.
12. Remove wheel block after machine has been completely lowered.

MACHINE STORAGE

If the machine is to be stored for extended periods of time, the following steps must be taken to minimize the chance of corrosion or deposits forming.

1. Drain both solution and recovery tanks. Clean soil and chemical build up from tank. Flush with clean water including the solution delivery system. Leave solution tank lid and recovery tank dome open.
2. Raise the rear squeegee assembly and the scrub deck.
3. Remove brushes and rinse with clean water. Dry thoroughly.
4. Wash squeegee blades with clean water.
5. Park the machine in a cool, dry area.
6. Check the charge level of the batteries monthly. Recharge when batteries drop below 25% charge. If suitable space exists to store batteries from machine, remove from machine.
7. Perform next lubrication interval.



MAINTENANCE

SERVICE SCHEDULE





MAINTENANCE	BEFORE EACH WORK PERIOD	AFTER EACH WORK PERIOD	50 HRS	100 HRS	200 HRS
Check water level of batteries after charging; add distilled water if necessary	*				
Check that recovery tank cover seals tightly	*				
Visually check for damaged or worn tires	*				
Check brushes or pads for proper installation	*				
Check vacuum hose connections	*				
Check that squeegee is securely attached and properly adjusted	*				
Check that side squeegees are properly adjusted	*				
Check for securely attached drain hose, plug and caps	*				
Check brakes and steering for proper operation	*				
Inspect vacuum filter for debris		*			
Clean out solution tank and filter, check flow		*			
Run vacuum motors to dry		*			
Clean brushes or pads and check wear		*			
Clean main and side squeegee blades and check wear		*			
Clean out recovery tank and vacuum filter		*			
Clean and inspect float shutoff		*			
Clean outside of tanks, check for damage		*			
Store with covers off tanks		*			
Charge batteries		*			
Check side squeegee for wear			*		
Clean off top of batteries			*		
Check battery cells with hydrometer			*		
Inspect scrub deck skirts			*		
Clean solution strainers			*		
Check battery connections are tight			*		
Clean battery cases and battery compartment				*	
Check parking brake adjustment					*
Check brakes discs and calipers for damage or wear					*
Clean pivot points on squeegee and scrub deck					*
Check all motors for carbon brush wear					*
Check motor commutators					*
Check steering chain tensioner					*

NOTE: Traction drive, wheels and batteries should be serviced based on traction drive hour meter. The scrub brush hour meter should be used for all other service schedule items.

MACHINE TROUBLESHOOTING

PROBLEM	CAUSE	ERROR CODE	SOLUTION
No power to machine	Battery disconnected		Check connections of all battery cable connections
	Emergency shut-off activated		Reset
	Battery cables corroded		Clean connections
	Main fuse blown		Replace fuse
	Faulty key switch		Replace switch
Little or no propel	Low battery charge		Charge batteries
	Machine turned on with pedal not in neutral position		Allow pedal to return to neutral Restart.
	Wheels spin		Decrease brush pressure
	Controller overheated	7802/7801	Allow cool down period
	Loose motor connection	7800	Check wires and connections from controller to motor
	Loose throttle connections or faulty throttle potentiometer	0814	Check wires and connections from throttle to LCD and potentiometer resistance
	Loose brake switch connection or faulty brake switch		Check connections and switch continuity
	Loose seat switch connection or faulty seat switch		Check connections and switch continuity
Forward speed only	Faulty throttle		Check throttle
Reverse speed only	Faulty throttle		Check throttle
Poor or no water pick-up	Squeegee out of adjustment		Adjust squeegee
	Debris caught on squeegee		Remove debris
	Worn squeegee blades		Rotate or replace squeegee blades
	Vacuum hose clogged		Clear obstruction from hose
	Vacuum hose disconnected from squeegee or recovery tank		Reconnect vacuum hose
	Vacuum hose damaged		Replace hose
	Vacuum motor inlet filter dirty		Clean or replace inlet filter
	Recovery tank not sealed		Replace damaged seals
	Foam filling recovery tank		Empty recovery tank use less or different detergent Use defoamer
Squeegee will not go up/down	Faulty actuator		Repair/replace actuator
	Loose connection		Check wires and connections from controller to actuator

MACHINE TROUBLESHOOTING

PROBLEM	CAUSE	ERROR CODE	SOLUTION
Vacuum motor does not run, or runs slowly	Recovery tank full		Drain recovery tank
	Recovery tank float switch dirty		Clean float switch
	Loose motor connection	7700	Check motor wires and connections
	Worn vacuum motor brushes		Replace brushes, check commutator
Poor scrubbing performance	Debris caught in scrub brushes		Remove debris
	Worn brushes or pads		Replace brushes or pads
	Improper detergent, brush or pad used		Contact equipment or application specialists
	Low scrub brush down pressure		Increase brush pressure
	Low battery charge		Charge batteries
Little or no solution flow to the floor	Solution tank empty		Fill solution tank
	Solution flow turned off or set too low		Turn on or increase flow setting
	Solution strainer plugged		Clean solution strainer
	Solution system plumbing obstructed		Clear obstruction from plumbing
	Solution solenoid valve obstructed or stuck		Clean or replace valve
	Vent hole in solution tank lid obstructed		Clear obstruction from vent hole
	Faulty solenoid valve connection		Check wiring to solution valve
Brush motors do not run, or run slowly	Circuit breaker(s) tripped	7600	Reset circuit breaker(s)
	Low battery charge		Charge battery
	Loose connection	7600	Check motor wires and connection
	Worn brush motor brushes		Replace brushes, check commutator
Scrub deck will not go down/up	Faulty actuator	9000	Repair/replace actuator
	Loose connection	9000	Check motor wires and connections
Scrub deck goes down, then raises	No brushes or pad drivers on machine	9000	Install brushes or pad drivers
Error code not listed is displayed	Controller detects electrical problem		Contact service technician