

LUMEX[®]

AQ1000 / AQ2000

ALTERNATING PRESSURE BUBBLE PAD AND PUMP SYSTEM



USER MANUAL

**Important: Do not operate the Mattress System
without first reading and understanding this manual!
Save this manual for future use.**

**The latest version of this manual can be found online
at www.grahamfield.com.**

CONTENTS

INTRODUCTION	3
INTENDED USE OF THIS DEVICE	3
CONTRAINDICTION	3
DANGER	4
WARNING	4
NOTICE	5
EQUIPMENT SYMBOLS	6
PRODUCT DESCRIPTION	7
BUBBLE PAD AND PUMP SYSTEM	7
PUMP	7
FRONT PANEL	8
AQ1000	8
AQ2000	8
INSTALLATION	9
UNPACKING	9
PUMP AND BUBBLE PAD INSTALLATION	9
OPERATION	11
AQ2000 ONLY: PRESSURE ADJUSTMENT	11
QUICK DISCONNECT	11
CPR FUNCTION	11
MAINTENANCE	12
CLEANING	12
PUMP	12
BUBBLE PAD	12
GENERAL MAINTENANCE	12
FUSE REPLACEMENT (220V SYSTEM ONLY)	13
STORAGE	13
SPECIFICATIONS	14
WARRANTY	15

GF Health Products, Inc. is not responsible for typographical errors. All illustrations, specifications, packaging and warranties contained in this document are based on the latest product information available at the time of printing. The most current product information, including the most current revision of this manual, can be found online at www.grahamfield.com. **Graham-Field** and **Lumex** are registered trademarks of GF Health Products, Inc.

INTRODUCTION

Use this manual for setup and operation of the Lumex AQ1000 / AQ2000 Alternating Pressure Pad and Pump System. Read all instructions before using the pad and pump system. Save this manual for future reference.

INTENDED USE OF THIS DEVICE

The intended use of the Alternating Pressure Pad and Pump System, in either a homecare or long-term care setting, is the treatment of pressure ulcers while optimizing user comfort, and pain management as prescribed by a physician.

Contraindication

⚠ WARNING: DO NOT use this product in the presence of flammable anesthesia. There is a possible fire hazard when this product is used with certain oxygen delivery equipment.

Use nasal cannula, face mask, or 1/2 length oxygen tent to deliver oxygen in the presence of this product.

DO NOT use a full length oxygen tent that extends past the top surface of the mattress with this product.

IMPORTANT SAFETY PRECAUTIONS

The safety statements presented in this chapter refer to the basic safety information that should be observed by those using the Alternating Pressure Pad and Pump System. There are additional safety statements in other chapters or sections, which may be the same as or similar to the following, or specific to the operations.

⚠ DANGER: Indicates an imminent hazard situation that, if not avoided, will result in death or serious injury.

⚠ WARNING: Indicates a potential hazard situation or unsafe practice that, if not avoided, could result in death or serious injury.

⚠ **CAUTION:** Indicates a potential hazard or unsafe practice that, if not avoided, could result in minor or moderate personal injury.

▲ **NOTICE:** Indicates a potential hazard or unsafe practice that, if not avoided, could result in product or property damage.

Info: Provides application recommendations or other useful information to ensure that you get the most from your product.

DANGER

To reduce the risk of electrocution:

⚠ **DANGER:** Always unplug this product immediately after using.

⚠ **DANGER:** Do not use this product while bathing.

⚠ **DANGER:** Do not place or store this product where it can fall or be pulled into a tub or sink.

⚠ **DANGER:** Do not place this product in or drop into water or other liquid.

⚠ **DANGER:** Do not reach for a product that has fallen into water. Unplug it *immediately*.

WARNING

To reduce the risk of burns, electrocution, fire, or personal injury:

⚠ **WARNING:** Do not leave this product unattended when plugged in.

⚠ **WARNING:** Always use close supervision when this product is used by, on, or near children or those who require close supervision.

⚠ **WARNING:** Use this product only as intended and described in this manual. Do not use attachments or accessories not recommended by GF Health Products, Inc..

⚠ WARNING: Never operate this product if

- a) it has a damaged cord or plug.
- b) it is not working properly.
- c) it has been dropped or damaged.
- d) it has been dropped into water.

Return the product to your Graham-Field authorized distributor.

⚠ WARNING: Keep the cord away from heated surfaces.

⚠ WARNING: Never block the air openings of this product or place it on a soft surface, such as a bed or couch, where the openings may be blocked. Keep the air opening free of lint, hair, and other similar particles.

⚠ WARNING: Never drop or insert any object into any opening or hose.

⚠ WARNING: Connect this product *only* to a properly grounded power outlet.





⚠ WARNING: Maximum patient weight capacity for this product is 275 lb (125 kg), **EVENLY DISTRIBUTED.**

⚠ WARNING: Notice for California Customers- California Proposition 65 **WARNING: This product contains a chemical known to the State of California to cause cancer and reproductive or developmental harm.**

NOTICE

▲ NOTICE: The pump can be used only with the accompanying bubble pad. Do not use it for any other purpose.

EQUIPMENT SYMBOLS

	Attention! Consult accompanying documents (this manual)
	“BF”symbol: Indicates that this product is in accordance with the degree of protection against electric shock for type BF equipment
	Grounding terminal
	Class II (for UL only)
	Disposal of Electrical & Electronic Equipment (WEEE): Do not treat this product as household waste. For more detailed information with regard to returning and recycling this product, please consult your local city office, household waste disposal service, or Graham-Field authorized distributor.

The system has been tested and successfully approved with the following standards:

U.S.	UL 1431	
Europe		EN 60601-1, EN 60601-1-2, EN 55011 Class B, EN 61000-3-2, EN 61000-3-3, IEC 801-2, IEC 801-3, IEC 801-4, IEC 801-5

PRODUCT DESCRIPTION

BUBBLE PAD AND PUMP SYSTEM

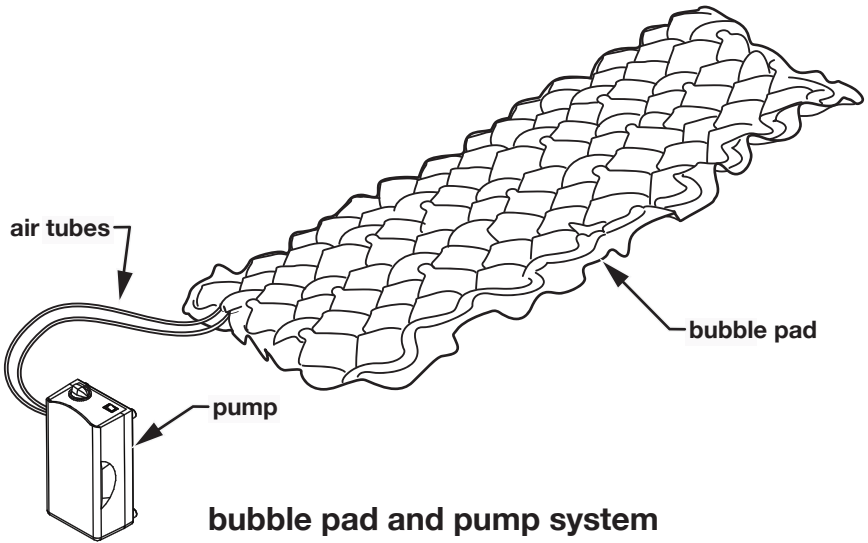

PUMP

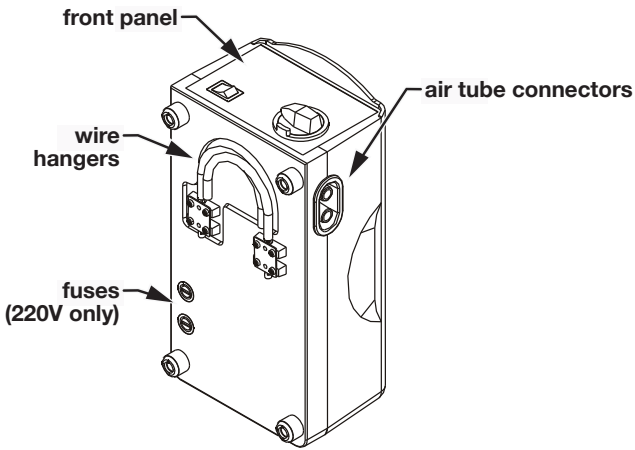

pump (AQ2000 shown)

FRONT PANEL

AQ1000

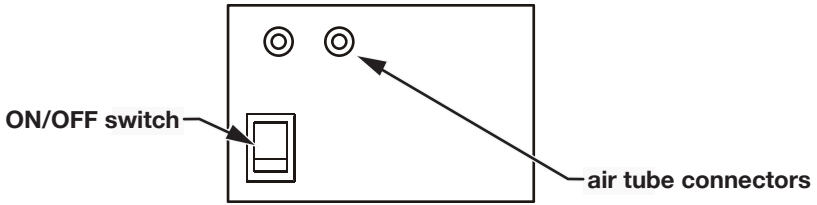

AQ1000 pump front panel

AQ2000

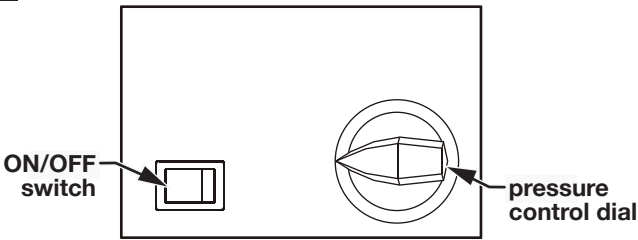

AQ2000 pump front panel

Front panel pressure control dial (AQ2000 only): The pressure control dial controls the air pressure output. To increase pressure, turn the dial clockwise. To decrease pressure, turn the dial counter-clockwise.

INSTALLATION

UNPACKING

1. Before unpacking, check for obvious damage to the carton or its contents. If damage is evident, please notify the carrier and your Graham-Field authorized distributor.
2. Remove all loose packing from the carton.
3. Carefully remove all components from the carton.
4. Inspect all components. If damage is evident, please notify the carrier and your Graham-Field authorized distributor.

PUMP AND BUBBLE PAD INSTALLATION

1. Remove all sheets, blankets, and pillows from the bed.
2. Place the bubble pad on the bed mattress with the tubing at the patient's feet.

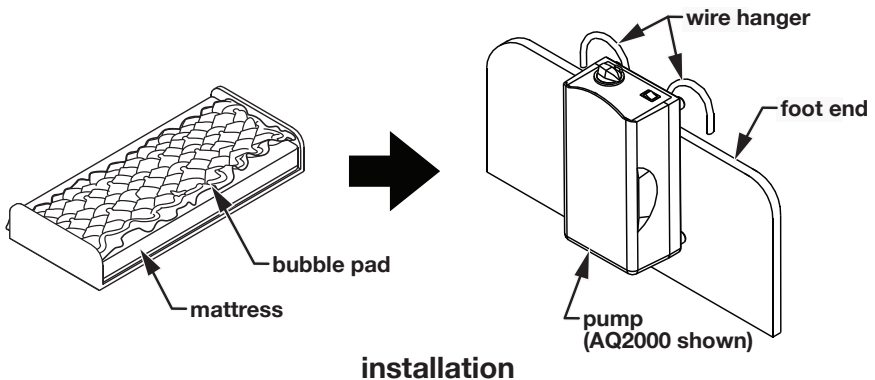

3. Fold open the wire hangers on the back of the pump as shown above.
4. Use the hangers to hang the pump on the bed's foot end, as shown above; adjust the hangers to place the pump in the most upright position (or place the pump on a flat surface easily accessible to the caregiver and/or doctor).

▲ NOTICE: Place the device in a position where the caregiver and/or doctor can access it easily.

5. Connect one end of the air tubes to the bubble pad: slide the ends of the air tubes over the connectors on the top of the foot end of the bubble pad.
6. Connect the other end of the air tubes to the pump connectors; ensure that the ends of the air tubes are firmly fitted over the bubble pad and pump connectors before continuing.
 - ▲ **NOTICE:** Ensure that the air tubes are not kinked or tucked under the bubble pad or mattress.
 - ⚠ **WARNING:** Locate all cords so that they will not be stepped on, tripped over, or otherwise subjected to damage or stress.
 - ⚠ **WARNING:** Do not use a household extension cord if the electrical cord does not reach the power outlet. Use of an improper extension cord could result in fire and electric shock. If an extension cord must be used, use a three conductor cord with ground, properly wired, in good electrical condition, and keep it as short as possible.
 - ⚠ **WARNING:** This device—which **MUST** be grounded—is equipped with a cord that has a grounding wire with a grounding plug. The plug must be plugged into an outlet that is properly installed and grounded.
 - ⚠ **WARNING:** Ensure that the local power voltage is appropriate for the pump unit.
7. Plug the power cord into a properly grounded electrical outlet.

OPERATION

1. Turn the ON/OFF switch to the ON position. The pump will begin to deliver air into the bubble pad.
2. Replace all sheets, blankets, and pillows on the bed.

Info: if the pressure level seems low, check for any leakage in the air tubes or bubble pad. Replace any damaged tubes. If necessary, contact your Graham-Field authorized distributor for repair or replacement.

AQ2000 ONLY: PRESSURE ADJUSTMENT

Adjust the pressure control dial for comfort.

Info: For maximum effectiveness, patient should sink into bubble pad to reduce pressure points. Ensure that patient does not bottom out.

QUICK DISCONNECT

Pull the power plug from the wall connector to disconnect the device quickly.

CPR FUNCTION

If CPR must be performed on the patient while the bubble pad is in use, to immediately deflate the bubble pad, pull the air tubes off the bubble pad or pump connectors.

MAINTENANCE

CLEANING

Perform the following cleaning procedures before use and as necessary thereafter.

Pump

Wipe the pump with a clean, damp cloth and mild detergent, and keep it away from dust. Air dry.

▲ **NOTICE: Do not use phenolic products or corrosive or powdered cleansers to clean the pump.**

▲ **NOTICE: Do not immerse or soak the pump.**

Bubble pad

Wipe the bubble pad with a clean, damp cloth and mild detergent. The bubble pad may also be cleaned using a 10% solution of sodium hypochlorite (bleach) diluted in water. Air dry all parts thoroughly before use.

▲ **NOTICE: Do not use phenolic products to clean the bubble pad.**

▲ **NOTICE: After cleaning, air dry the bubble pad without direct exposure to sunlight.**

GENERAL MAINTENANCE

1. Check main power cord for abrasion or excessive wear.
2. Check bubble pad for signs of wear or damage. Ensure air tubes are firmly secured to bubble pad and pump connectors.
3. Check the air tubes for kinks or breaks. For replacement, please contact your Graham-Field authorized distributor.

Fuse replacement (220V system only)

tool needed: small screwdriver

1. If you suspect a blown fuse, disconnect the plug from the wall outlet immediately.

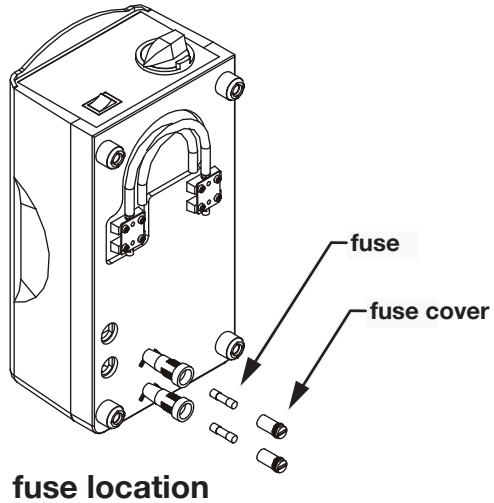

2. Use a small screwdriver to remove the cover of the fuse holder (fuse locations are shown in picture above).
3. Insert a new fuse of the correct rating (T1A/250V).
4. Replace the fuse holder cover. Ensure that fuse holder cover is securely installed.

STORAGE

1. Fold the bubble pad loosely.
2. Store bubble pad and pump in a dust-free environment with no exposure to direct sunlight.

SPECIFICATIONS

Model	AQ1000 (Standard)	AQ2000 (Deluxe)
Power Supply	120V: 120V AC, 60 Hz, 1A	
	220V: 230VAC, 50 Hz, 7W	
Fuse Rating	120V: N/A	
	220V: T1A, 250V	
Pressure	1.9 psi (13.10 kPa)	1.0 - 2.0 psi (6.89-13.79 kPa)
Air Output	120V: 4.5 LPM	120V: 4-5 LPM
	220V: 5.0 LPM	220V: 5-6 LPM
Cycle Time	120V: 5 min.	
	220V: 6 min.	
Power Cord Length	10 ft. (304.8 cm)	
Pump Unit Size	8.5 x 4.25 x 3.62 in. (21.59 x 10.80 x 9.19 cm)	9.75 x 5.12 x 3.88 in. (24.77 x 13.00 x 9.86 cm)
Pump Unit Weight	2.9 lb. (6.38 kg)	3.5 lb. (7.7 kg)
Bubble pad Size, Inflated	78 x 34 x 2.5 in. (198.12 x 86.36 x 6.35 cm)	76 x 34 x 2.5 in. (193.04 x 86.36 x 6.35 cm)
Weight Capacity	275 lb. (125 kg), EVENLY DISTRIBUTED	
Bubble pad Material	14 GA anti-bacterial, flame-retardant vinyl	
Tubing	2 each: 5 ft. (152.4 cm) long clear PVC	
Replacement Parts	Contact your Graham-Field dealer or visit Graham Field's website, www.grahamfield.com	

Info: Specifications are subject to change without notice.

WARRANTY

GF Health Products, Inc. warrants the Lumex AQ1000 / AQ2000 Alternating Pressure Pad and Pump System for defects in workmanship and materials for the terms listed below.

Pump: one year

Pad: 90 days

If a product is deemed to be under warranty, GF Health Products, Inc. shall provide, at its option, (1) replacement of any defective part or product or (2) a credit of the original selling price made to GF Health Products, Inc.'s initial customer. The warranty does not include any labor charges incurred in replacement part(s) installation or any associated freight or shipping charges to GF Health Products, Inc.

The warranties contained herein contain all the representations and warranties with respect to the subject matter of this document, and supersede all prior negotiations, agreements and understandings with respect thereto. The recipient of this document hereby acknowledges and represents that it has not relied on any representation, assertion, guarantee, warranty, collateral contract or other assurance, except those set out in this document.

**GF Health Products, Inc.
2935 Northeast Parkway
Atlanta, Georgia 30360**

tel: 770-368-4700

fax: 770-368-2386



GRAHAM-FIELD®

www.grahamfield.com

© 2008 GF Health Products, Inc.