

# Panasonic

## Quick Reference Guide

Colour Laser Multi-Function Printer  
Model No. **KX-MC6020CX**

**Do NOT connect the unit to a computer with the USB cable until prompted by the Multi-Function Station (CD-ROM).**

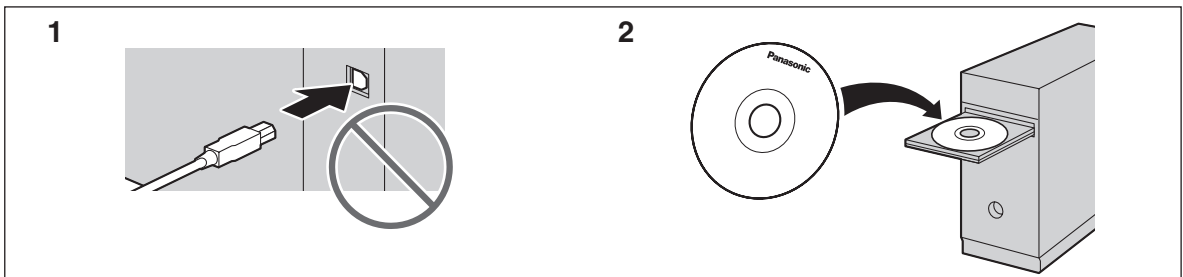

This Quick Reference Guide provides safety instructions and a basic description of the unit's functions. An illustrated leaflet provides instructions for easy installation. Please read before using the unit and save for future reference.

The supplied Setup CD-ROM provides the Operating Instructions in PDF format with a detailed description on how to use the unit. Adobe® Reader® is required to view them.

**Be sure to use the USB cable supplied with this unit.**

- **This unit is compatible with Caller ID. You must subscribe to the appropriate service offered by your service provider/telephone company.**
- **Be sure to use the telephone line cord supplied with this unit.**

### Location selection:

**Designed to be used in Middle East, Malaysia, Asia, Australia, New Zealand, Africa and Latin America according to the location setting feature.**

The default setting is Middle East. To change the location setting, see following:

1. **[Menu] → [#][1][1][4]**
2. Press **[1]** to **[7]** to select the desired location. → **[Set] → [Menu]**

**[1]** "MIDDLE EAST" (default): To use in Middle East.

**[2]** "MALAYSIA": To use in Malaysia.

**[3]** "ASIA": To use in Asia.

**[4]** "AUSTRALIA": To use in Australia.

**[5]** "NEW ZEALAND": To use in New Zealand.

**[6]** "AFRICA": To use in Africa.

**[7]** "LAT . AMERICA": To use in Latin America.

**Thank you for purchasing a Panasonic Multi-Function Printer.**

**User record (for your future reference)**

Date of purchase

Serial number (found on the rear of the unit)

Dealer's name and address

Dealer's telephone number

**Attach your sales receipt here.**

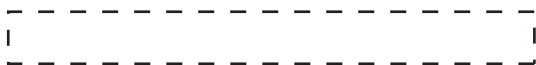

**You can select English or Spanish for the language.**

The display and reports will be in the selected language. The default setting is English. If you want to change the setting, see following:

1. **[Menu]** → **[#][1][1][0]**
2. Press **[1]** or **[2]** to select the desired language. → **[Set]** → **[Menu]**  
**[1]** "ENGLISH" (default): English is used.  
**[2]** "SPANISH": Spanish is used.

**This model is designed to be used in Middle East, Malaysia, Asia, Australia, New Zealand, Africa and Latin America according to the location setting feature.**

The default setting is Middle East. To change the location setting, see page 1 (feature #114).

**Notice for product disposal, transfer, or return:**

- This product can store your private/confidential information. To protect your privacy/confidentiality, we recommend that you erase the information such as phonebook (or caller information) from the memory before you dispose of, transfer or return the product.

**Environment:**

- Panasonic's strategic direction incorporates concern for the environment into all aspects of the product life cycle, from product development to energy saving designs; from greater product reusability to waste-conscious packaging practices.

**Trademarks:**

- Windows and Windows Vista are either registered trademarks or trademarks of Microsoft Corporation in the United States and/or other countries.
- Adobe and Reader are either registered trademarks or trademarks of Adobe Systems Incorporated in the United States and/or other countries.
- All other trademarks identified herein are the property of their respective owners.

**Copyright:**

- This material is copyrighted by Panasonic Communications Co., Ltd., and may be reproduced for internal use only. All other reproduction, in whole or in part, is prohibited without the written consent of Panasonic Communications Co., Ltd.

© 2008 Panasonic Communications Co., Ltd. All Rights Reserved.

## For Australian users

### Warning:

- Please ensure that a separate telephone, not dependent on local power, is available for emergency use.
- This equipment will be inoperable when mains power fails.
- When a failure occurs which results in the internal parts becoming accessible, disconnect the power supply cord immediately and return this unit to an authorised service centre.
- Disconnect the telephone connection before disconnecting power connection prior to relocating the equipment, and reconnect the power first.
- To minimize the possibility of lightning damage, when you know that a thunderstorm is coming, we recommend that you:
  - A. Unplug the telephone line cord from the phone jack.
  - B. Unplug the power supply cord from the AC power outlet.
- No "000" or other calls can be made from this device during a mains power failure.
- The earcap on the handset is magnetised and may retain metallic objects.

## For New Zealand users

### Warning:

- WHEN A FAILURE OCCURS WHICH RESULTS IN THE INTERNAL PARTS BECOMING ACCESSIBLE, DISCONNECT THE POWER SUPPLY CORD IMMEDIATELY AND RETURN THIS UNIT TO AN AUTHORISED SERVICE CENTRE.
- DISCONNECT THE TELECOM CONNECTION BEFORE DISCONNECTING THE POWER CONNECTION PRIOR TO RELOCATING THE EQUIPMENT, AND RECONNECT THE POWER FIRST.
- NO "111" OR OTHER CALLS CAN BE MADE FROM THIS DEVICE DURING A MAINS POWER FAILURE.

### IMPORTANT NOTICE

Under power failure conditions, this telephone may not operate. Please ensure that a separate telephone, not dependent on local power, is available for emergency use.

### Notice:

- The grant of a Telepermit for any item of terminal equipment indicates only that Telecom has accepted that the item complies with minimum conditions for connection to its network. It indicates no endorsement of the product by Telecom, nor does it provide any sort of warranty. Above all, it provides no assurance that any item will work correctly in all respects with another item of Telepermitted equipment of a different make or model, nor does it imply that any product is compatible with all of Telecom's network services.
- This equipment shall not be set to make automatic calls to the Telecom "111" Emergency Service.
- This equipment should not be used under any circumstances which may constitute a nuisance to other Telecom customers.
- Not all telephones will respond to incoming ringing when connected to the extension socket.
- Different characteristics of the equipment at the other end of the call, and/or variations in line conditions, may mean that it will not always be possible to communicate at the higher speeds for which this machine has been designed. Neither Telecom or Panasonic New Zealand can accept responsibility should this situation arise.

# Important information (for Australian users)

## Instructions to customer

### Installation

Attached to this apparatus is an approval label. This label is evidence that it is a "Permitted Attachment" which has been authorised to be connected to your telephone service.

Conditions relating to connection and operation of this Permitted Attachment are contained in Telecommunications General By-Law 220 (5).

You are authorised to install this Permitted Attachment yourself by plugging it into the line socket of any regular telephone. You may connect it in place of your existing telephone or to any spare telephone socket installed in your premises.

To disconnect your existing telephone you must first remove its plug from the line socket. You can then insert the plug of your Permitted Attachment into the socket and use your equipment.

If the plug of your existing telephone cannot be readily removed, you will have to remove the screw securing it. To do this proceed as follows:

1. Loosen screw "A" sufficiently to remove the socket cover. (See Fig. 1.)
2. Remove screw "B" and withdraw the plug. (See Fig. 2.)
3. Replace screw "B". (See Fig. 3.) Ensure that it screws completely into the socket recess. (If the screw is too long, increase the hole depth or replace the screw with one 5 mm shorter.)
4. Replace socket cover and tighten screw "A". (See Fig. 4.)

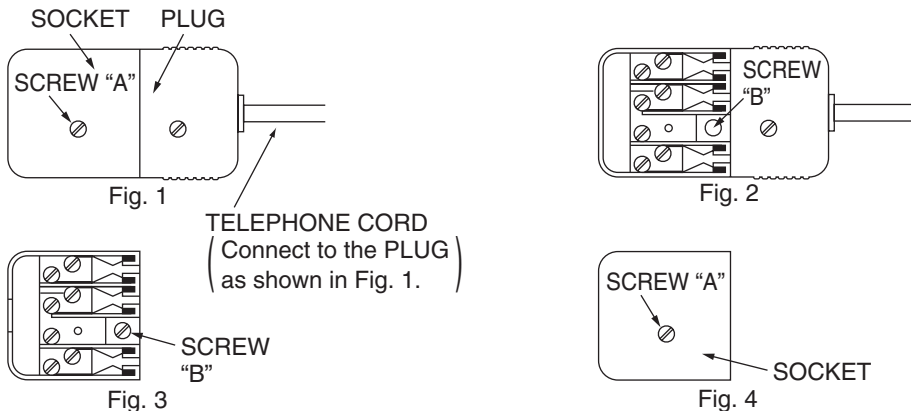

If you are satisfied with the operation of your telephone service after plugging in your Permitted Attachment, your installation is completed.

You will be unable to connect this Permitted Attachment if your telephone service consists only of a wall phone or an old style telephone which is not connected by means of a modern plug and socket. In such cases a new socket will need to be installed.

Should the Permitted Attachment not operate when plugged into a socket, it is either faulty or unsuitable for operation with your telephone service. It should be returned to the store where purchased.

### Service difficulties

If at any time a fault occurs on your telephone service carry out the following checks before you call for service:

- Disconnect the Permitted Attachment and try using the service with the normal telephone.
- If the telephone service then operates satisfactorily, the fault is in your Permitted Attachment. Leave the Permitted Attachment disconnected and report the fault to its supplier or agent to arrange for repair.
- If when using the telephone the service is still faulty, report the fault to "Service Difficulties and Faults" for attention.

You are required to keep this Permitted Attachment in good working order while it is connected to your telephone service. Its construction or internal circuit must not be modified in any way without permission.

## For your safety

To prevent severe injury and loss of life/property, read this section carefully before using the unit to ensure proper and safe operation of your unit.

- The following symbols are used to classify and describe the level of hazard and injury caused when the denotation is disregarded and improper use is performed.

### **WARNING**

Denotes a potential hazard that could result in serious injury or death.

### **CAUTION**

Denotes hazards that could result in minor injury or damage to the unit.

- The following symbols are used to classify and describe the type of instructions to be observed.



This type of symbol is used to alert users to a specific operating procedure that must be performed carefully.



This type of symbol is used to alert users to a specific operating procedure that must not be performed.



This type of symbol is used to alert users to a specific operating procedure that must be emphasized in order to operate the unit safely.



## WARNING

### Power and ground connection



Use only the power source marked on the unit. If you are not sure of the type of power supplied to your home, consult your dealer or local power company.



For safety purposes this unit is equipped with a grounded plug. If you do not have this type of outlet, please have one installed. Do not defeat this safety feature by tampering with the plug.



Do not place objects on the power cord. Install the unit where no one can step or trip on the cord.



Do not overload power outlets and extension cords. This can result in the risk of fire or electric shock.



Completely insert the AC adaptor/power plug into the power outlet. Failure to do so may cause electric shock and/or excessive heat resulting in a fire.



Regularly remove any dust, etc. from the AC adaptor/power plug by pulling it from the power outlet, then wiping with a dry cloth. Accumulated dust may cause an insulation defect from moisture, etc. resulting in a fire.



Unplug this unit from power outlets if it emits smoke, an abnormal smell or makes unusual noise. These conditions can cause fire or electric shock. Confirm that smoke has stopped and contact an authorised service centre.



Never touch the plug with wet hands. There is a danger of electric shock.

### Installation



Place the unit securely on a stable, level surface. Serious damage and/or injury may result if the unit falls.



To prevent the risk of fire or electrical shock, do not expose this product to rain or any type of moisture.

## Important Information



Make sure that the unit is installed in a well ventilated room so as not to increase density of ozone in the air. Since ozone is heavier than air, it is recommended that air at floor level be ventilated.

### Operating safeguards



Turn the power switch OFF before cleaning. Do not use liquid or aerosol cleaners.



Do not cover slots and openings on the unit. They are provided for ventilation and protection against overheating. Never place the unit near radiators, or in a place where proper ventilation is not provided.



Never push any objects through slots in this unit. This may result in the risk of fire or electric shock. Never spill any liquid on the unit.



To reduce the risk of electric shock, do not disassemble this unit. Take the unit to an authorised service centre when service is required. Opening or removing covers may expose you to dangerous voltage or other risks. Incorrect reassembly can cause electric shock when the unit is subsequently used.



Follow all warnings and instructions marked on this unit.



Do not spill liquids (detergents, cleansers, etc.) onto the telephone line cord plug, or allow it to become wet at all. This may cause a fire. If the telephone line cord plug becomes wet, immediately pull it from the telephone wall jack, and do not use.



Unplug this unit from power outlets and refer servicing to an authorised service centre when any of the following conditions occur:

- If the power cord is damaged or frayed.
- If liquid has been spilled into the unit.
- If the unit has been exposed to rain or water.
- If the unit does not work normally by following the operating instructions. Adjust only controls covered by the operating instructions. Improper adjustment may require extensive work by an authorised service centre.
- If the unit has been dropped or physically damaged.
- If the unit exhibits a distinct change in performance.



## CAUTION

### Installation and relocation

After moving the unit from cold areas to warmer areas, wait approximately 30 minutes before turning on the power switch to allow the unit to adjust to the ambient temperature. If the power switch is turned on too soon after a sudden climate change, condensation may form inside the unit, causing malfunction.



Never turn the unit upside down or sideways when moving it.



Never install telephone wiring during a lightning storm.



Never install telephone jacks in wet locations unless the jack is specifically designed for wet locations.



Never touch uninsulated telephone wires or terminals unless the telephone line has been disconnected at the network interface.



Use caution when installing or modifying telephone lines.



Do not position the unit in a location where it is unstable or subject to vibrations.

**Laser radiation**

CLASS 1 LASER PRODUCT



The printer of this unit utilises a laser. Use of controls or adjustments or performance of procedures other than those specified herein may result in hazardous radiation exposure.

See the operating instructions for the Laser diodes properties.

**Fuser unit**



During or immediately after printing, the fuser unit gets hot. This is normal. Do not touch the fuser unit.

**Note:**

- The area near the recording paper exit also gets warm. This is normal.

**Toner cartridge**

Be careful of the following when you handle the toner cartridge:



If you ingest any toner, drink several glasses of water to dilute your stomach contents, and seek immediate medical treatment.



If any toner comes into contact with your eyes, flush them thoroughly with water, and seek medical treatment.



If any toner comes into contact with your skin or clothing, wash the area thoroughly with cold water, then air dry. Do not use hot water or hair dryer. If there is skin irritation, seek immediate medical treatment.



If you inhale any toner, move to an area with fresh air and consult local medical personnel.

**USB cable**



Use only shielded USB cable (Example: Hi-Speed USB 2.0 certified cable).

**Important safety instructions**

When using this unit, basic safety precautions should always be followed to reduce the risk of fire, electric shock, or personal injury.

1. Do not use this unit near water, for example near a bathtub, wash bowl, kitchen sink, etc.
2. **For users other than Australia:**  
During thunderstorms, avoid using telephones except cordless types. There may be a remote risk of an electric shock from lightning.  
**For Australian users:**  
During thunderstorms, avoid using telephones including cordless phones. There is a risk of an electric shock from lightning.
3. Do not use this unit to report a gas leak, when in the vicinity of the leak.

**SAVE THESE INSTRUCTIONS**

### For best performance

#### Moving the unit

The unit weighs approximately 30 kg. It is highly recommended that two people handle this unit. When moving the unit, hold both of the side grips (①).

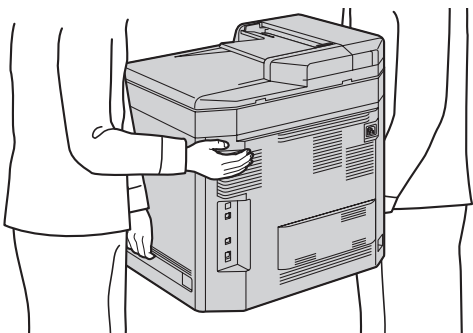
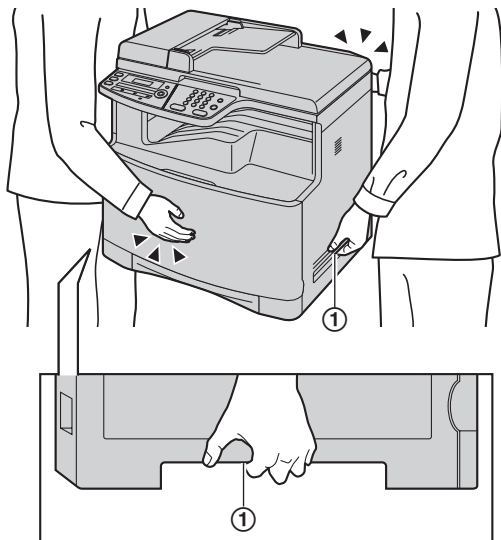

**Approx. 30 kg**

### Illegal copies

- It is unlawful to make copies of certain documents.

Copying certain documents may be illegal in your country. Penalties of fines and/or imprisonment may be imposed on those found guilty. The following are examples of items that may be illegal to copy in your country.

- Currency

- Bank notes and checks
- Bank and government bonds and securities
- Passports and identification cards
- Copyright material or trademarks without the consent of the owner
- Postage stamps and other negotiable instruments

**This list is not inclusive and no liability is assumed for either its completeness or accuracy. In case of doubt, contact your legal counsel.**

#### Notice:

- Install your machine near a supervised area to prevent illegal copies from being made.



---

---

## Operating instructions in the CD-ROM

The operating instructions on the CD-ROM consist of the following contents. Adobe Reader is required to view them.

- To view or install the operating instructions on the CD-ROM, see page 15.

### 1. Introduction and Installation

- Information prior to using the unit, for example how to install the toner cartridge and drum cartridge, and other accessories.

### 2. Preparation

- Main settings prior to activating the unit, such as Multi-function software information.

### 3. Printer

- More ways to use the printer, such as printing on special media.

### 4. Scanner

- More ways to use the scanner, such as saving as a file or sending as an e-mail attachment.

### 5. Copier

- More ways to use the copier, such as enlargement/reduction, and ways to reduce paper use.

### 6. Fax

- Convenient ways to send faxes such as using one-touch dial feature and navigator directory, and broadcast transmission.
- More ways to receive faxes, and preventing fax reception from undesired callers.

### 7. Caller ID

### 8. Distinctive Ring

### 9. Programmable Features

### 10. Useful Information

### 11. Help

- Troubleshooting

### 12. Paper Jams

### 13. Cleaning

### 14. General Information

- Specifications

---

---

## Table of Contents (Quick Reference Guide)

### 1. Introduction and Installation

#### Accessories

- 1.1 Supplied accessories ..... 11
- 1.2 Accessory information ..... 12

#### Connections and Setup

- 1.3 Connections ..... 12
- 1.4 Turning the power switch ON..... 13
- 1.5 Dialling mode..... 13
- 1.6 Selecting the operation mode (Scan/Copy/Fax) ..... 13

#### Document Requirements

- 1.7 Setting the original..... 13

#### Help

- 1.8 Help function ..... 14

#### Volume

- 1.9 Adjusting the volume ..... 14

#### Initial Programming

- 1.10 Date and time ..... 14
- 1.11 Your logo..... 14
- 1.12 Your fax number ..... 14
- 1.13 Configuring the unit to access the LAN ..... 15
- 1.14 Installing Multi-Function Station ..... 15

### 2. How to Use

#### Printer

- 2.1 Printing from Windows applications ..... 17

#### Scanner

- 2.2 Scanning from the unit (Push Scan)..... 17
- 2.3 Scanning from a computer (Pull Scan)..... 17

#### Copy

- 2.4 Making a copy ..... 17

#### Sending Faxes

- 2.5 Sending a fax manually ..... 17

#### Receiving Faxes

- 2.6 Receiving a fax automatically – Auto answer ON ..... 18

#### Useful Information

- 2.7 Cancelling the operations..... 18
- 2.8 Maintenance (Cleaning the drum cartridge) 18

### 3. Help

#### Error Messages

- 3.1 Error messages – Display ..... 19

## 1.1 Supplied accessories

- ① Toner cartridge (starter)  
(Cyan/Magenta/Yellow/Black)\*1

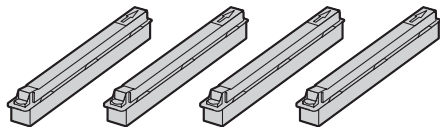

- ② Colour drum cartridge    ③ Monochrome drum cartridge

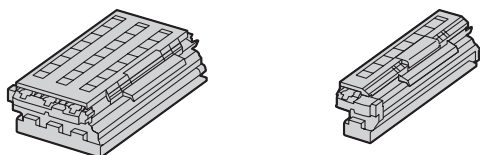

- ④ Waste toner cartridge (pre-installed inside the unit)    ⑤ CD-ROM

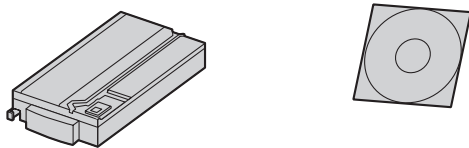

- ⑥ Quick reference guide    ⑦ Quick installation guide

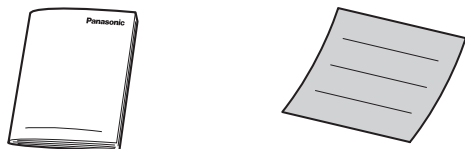

- ⑧ Power cord  
(Use the appropriate power cord for where you use the unit.)

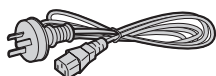

- ⑨ Telephone line cord  
(Use the appropriate telephone line cord for where you use the unit.)



- ⑩ USB cable

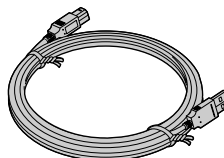

\*1 Prints about 1,000 A4-size pages with a 5 % coverage.

**Note:**

- Save the original carton and packing materials for future shipping and transportation of the unit.
- After unpacking the product, take care of the power plug cap and/or packing materials appropriately.
- Do not remove the drum cartridges and toner cartridges from the unit when repacking the unit for shipping and transportation.

## 1.2 Accessory information

To ensure that the unit operates properly, we recommend the use of Panasonic toner cartridge and drum cartridge.

### ■ Replacement accessory

#### – Toner cartridge

Colour	Model No. (Part No.)
Cyan	KX-FATC501A/KX-FATC501E
Magenta	KX-FATM502A/KX-FATM502E
Yellow	KX-FATY503A/KX-FATY503E
Black	KX-FATK504A/KX-FATK504E

- Prints about 2,000 sheets of A4-size pages with a 5 % coverage using KX-FATC501A/KX-FATC501E/KX-FATM502A/KX-FATM502E/KX-FATY503A/KX-FATY503E and about 2,500 sheets using KX-FATK504A/KX-FATK504E.

#### – Toner cartridge (high capacity)

Colour	Model No. (Part No.)
Cyan	KX-FATC506A/KX-FATC506E
Magenta	KX-FATM507A/KX-FATM507E
Yellow	KX-FATY508A/KX-FATY508E
Black	KX-FATK509A/KX-FATK509E

- Prints about 4,000 sheets of A4-size pages with a 5 % coverage.

#### – Colour drum cartridge

- Model No. (Part No.): KX-FADC510A/KX-FADC510E

#### – Monochrome drum cartridge

- Model No. (Part No.): KX-FADK511A/KX-FADK511E

#### – Waste toner cartridge

- Model No. (Part No.): KX-FAW505A/KX-FAW505E

### ■ Optional accessory

#### – Optional lower input tray

- Model No. (Part No.): KX-FAP317A/KX-FAP317E

#### – Automatic duplex unit

- Model No. (Part No.): KX-FAB318A/KX-FAB318E

## 1.3 Connections

### Caution:

- When you operate this product, the power outlet should be near the product and easily accessible.
- Be sure to use the telephone line cord supplied with this unit.

- Do not extend the telephone line cord.

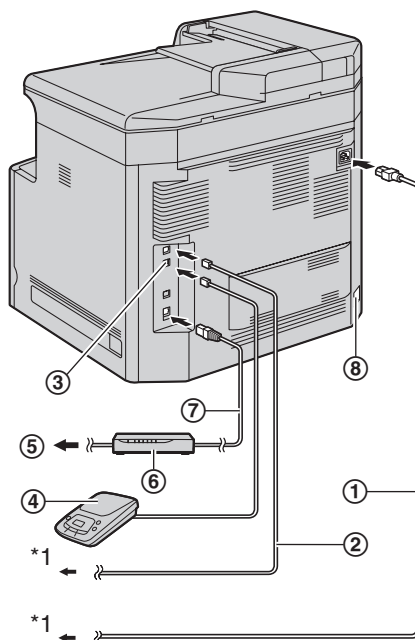

- ① Power cord
    - Connect to a power outlet (220–240 V, 50/60 Hz).
  - ② Telephone line cord
    - Connect to a single telephone line jack.
  - ③ [EXT] jack
    - You can connect an answering machine or an extension telephone. Remove the stopper if attached.
  - ④ Answering machine (not supplied)
  - ⑤ To the internet
  - ⑥ Network router/Network hub (not supplied)
    - Also connect networked computers.
  - ⑦ LAN cable (not supplied)
    - To assure continued emission limit compliance, use only shielded LAN cable (category 5 straight cable).
  - ⑧ Automatic duplex unit (optional) connector
- \*1 The power cord or telephone line cord may differ slightly. Use the appropriate power cord or telephone line cord for where you use the unit.

### IMPORTANT NOTICE FOR THE USB CONNECTION

- DO NOT CONNECT THE UNIT TO A COMPUTER WITH THE USB CABLE UNTIL PROMPTED BY THE MULTI-FUNCTION STATION (page 15).

### Note:

- If any other device is connected to the same telephone line, this unit may disturb the network condition of the device.

- A telephone handset cannot be connected directly to this unit. To talk to the other party, please connect an extension telephone.

**Designed to be used in Middle East, Malaysia, Asia, Australia, New Zealand, Africa and Latin America according to the location setting feature.** The default setting is Middle East. To change the location setting, see page 1 (feature #114).

#### Using network router/network hub

- We recommend using network routers/network hubs (⑥) under secure network environments. Consult your network administrator for firewall settings, etc.
- The warranty does not cover damage due to security problems or any disadvantages relating to it.

## 1.4 Turning the power switch ON

Turn the power switch to the ON position (①).

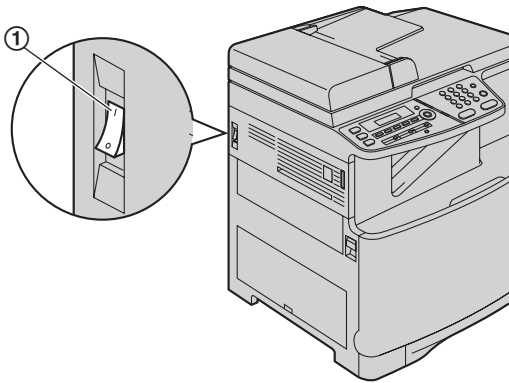

## 1.5 Dialling mode

#### Important:

- **Not available when "AUSTRALIA" or "NEW ZEALAND" is selected in feature #114.**

If you cannot dial, change this setting according to your telephone line service.

- 1 **[Menu]**
- 2 Press **[#][1][2][0]** to display "DIALLING MODE".
- 3 Press **[1]** or **[2]** to select the desired setting.  
**[1]** "PULSE": For rotary/pulse dial service.  
**[2]** "TONE" (default): For tone dial service.
- 4 **[Set]**
- 5 Press **[Menu]** to exit.

## 1.6 Selecting the operation mode (Scan/Copy/Fax)

You can select the desired mode by pressing one of the following buttons.

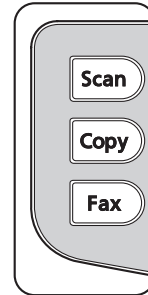

- **[Scan]**: Select this mode when using the unit as a scanner.
- **[Copy]**: Select this mode when using the unit as a copier.
- **[Fax]**: Select this mode when using the unit as a fax machine.

## 1.7 Setting the original

### 1.7.1 Using the scanner glass

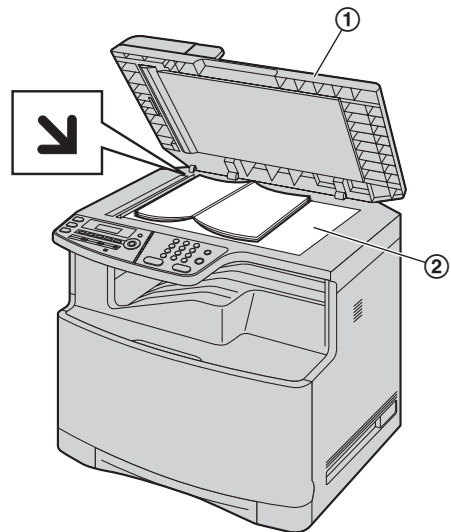

- 1 Open the document cover (①).
- 2 Place the document **FACE DOWN** on the scanner glass (②), aligning the top left of the document with the corner to which the  mark points.
- 3 Close the document cover.

### 1.7.2 Using the automatic document feeder

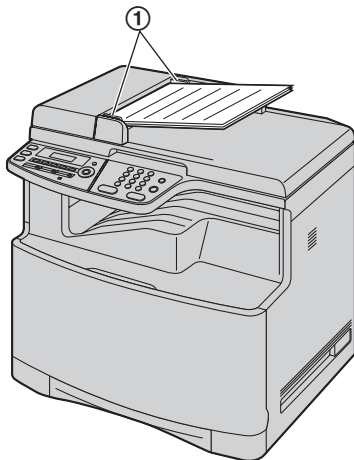

- 1 Insert the document (up to 50 pages) FACE UP into the feeder until a single beep is heard.
- 2 Adjust the width of the document guides (①) to fit the actual size of the document.

### 1.8 Help function

The unit contains helpful information, which can be printed for reference.

- "BASIC SETTINGS"
- "FEATURE LIST"
- "DIRECTORY"
- "FAX RECEIVING"
- "COPIER"
- "REPORTS"
- "CALLER ID"

- 1 Press **[Menu]** repeatedly to display "HELP".
- 2 Press **[◀]** or **[▶]** repeatedly to display the desired item. → **[Set]**
- 3 Press **[Menu]** to exit.

### 1.9 Adjusting the volume

**Important:**

- Before adjusting the volume, set the operation mode to fax mode. If the **[Fax]** light is OFF, turn it ON by pressing **[Fax]**.

**Ringer volume**

While the unit is idle, press **[▼]** or **[▲]**.

- The ringer volume can only be adjusted if there are no documents in the document entrance.

**To turn the ringer OFF**

Press **[▼]** repeatedly to display "RINGER OFF= OK?". → **[Set]**

- The unit will not ring.

- To turn the ringer back ON, press **[▲]**.

**Monitor volume**

While using the monitor, press **[▼]** or **[▲]**.

### 1.10 Date and time

- 1 **[Menu]** → **[#][1][0][1]** → **[Set]**

D: 01/M: 01/Y: 08  
TIME: 00:00

- 2 Enter the current date/month/year/hour/minute by selecting 2 digits for each. Press **[\*]** repeatedly to select "AM" or "PM", or 24-hour time entry.

**Example: 10 August, 2008 10:15 PM (12 hour clock format)**

1. Press **[1][0][0][8][0][8][1][0][1][5]**.

D: 10/M: 08/Y: 08  
TIME: 10:15

2. Press **[\*]** repeatedly to select "PM".

- 3 **[Set]**

- 4 Press **[Menu]** to exit.

### 1.11 Your logo

You can program your logo (name, company name, etc.) so that it appears on the top of each page sent.

- 1 **[Menu]** → **[#][1][0][2]** → **[Set]**

LOGO=

- 2 Enter your logo, up to 30 characters using the dial keypad. → **[Set]**

- 3 Press **[Menu]** to exit.

### 1.12 Your fax number

You can program your fax number so that it appears on the top of each page sent.

- 1 **[Menu]** → **[#][1][0][3]** → **[Set]**

NO. =

- 2 Enter your fax number, up to 20 digits.

- To enter a "+", press **[\*]**.
- To enter a space, press **[#]**.
- To enter a hyphen, press **[Flash]**.
- To erase a number, press **[Stop]**.

- 3 **[Set]**

- 4 Press **[Menu]** to exit.

## 1.13 Configuring the unit to access the LAN

You can print documents, scan documents, receive faxes or send faxes using a computer on the LAN. To enable these features, you need to set the IP address, subnet mask, and default gateway for the unit.

### Important:

- Consult your network administrator when setting the IP address, subnet mask, and default gateway.

### 1.13.1 Setting up automatically with a DHCP server

#### Your situation:

- When only one unit is connected to the LAN.

If your network administrator manages the network with a DHCP (Dynamic Host Configuration Protocol) server, it will automatically assign an IP (Internet Protocol) address, subnet mask, and default gateway to the unit.

- 1 After connecting the LAN cable to the unit and the computer, turn the power switch ON.
  - The IP address, subnet mask, and default gateway will be set automatically.
- 2 Install Multi-Function Station on the computer that you want to use it with.

## 1.14 Installing Multi-Function Station

- Install Multi-Function Station (CD-ROM) before connecting the unit to a computer with the USB cable. If the unit is connected to a computer with the USB cable before installing Multi-Function Station, the [Found New Hardware Wizard] dialogue box will appear. Click [Cancel] to close it.
- Software features and appearance are subject to change without notice.

### Warning:

- To assure continued emission limit compliance;
    - use only shielded USB cable (Example: Hi-Speed USB 2.0 certified cable).
    - use only shielded LAN cable (category 5 straight cable).
  - To protect the unit, use only shielded USB cable in areas where thunderstorms occur.
- 1 Start Windows® and exit all other applications.
    - For Windows 2000, Windows XP and Windows Vista® users, you must be logged in as an administrator in order to install Multi-Function Station.
  - 2 Insert the supplied CD-ROM into your CD-ROM drive.

### 3 [Easy Installation]

- The installation will start automatically.

- 4 When the setup program starts, follow the on-screen instructions.

- 5 The [Connect Type] dialogue box appears.

#### For USB connection:

1. [Connect directly with a USB cable.] → [Next]
  - The [Connect Device] dialogue box will appear.
2. Connect the unit to a computer with the USB cable (①), then click [Next].

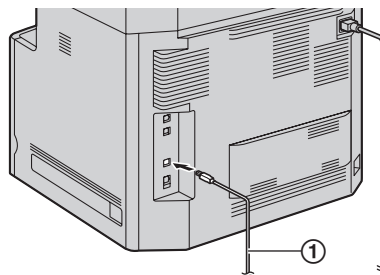

3. Click [Install], then follow the on-screen instructions.
  - The files will be copied to your computer.

#### For LAN connection:

1. [Connect via the Network.] → [Next]
  - The [Select a Network Device] dialogue box will appear.
2. Check [Select in the searched list] and select the unit from the list.
3. [Next]
4. Click [Install], then follow the on-screen instructions.
  - The files will be copied to your computer.

#### Important notice

If you use Windows XP or Windows Vista, a message may appear after connecting the unit with the USB cable. This is normal and the software will not cause any difficulties with your operating system. You can continue the installation with no problem. This kind of message is displayed:

##### • For Windows XP users

“The software you are installing for this hardware has not passed Windows Logo testing to verify its compatibility with Windows XP.”

##### • For Windows Vista users

“Would you like to install this device software?”

#### To view or install the operating instructions data

1. Start Windows and insert the supplied CD-ROM into your CD-ROM drive.

## 1. Introduction and Installation

---

2. Click [**Operating Instructions**], then follow the on-screen instructions to view or install the operating instructions in PDF format.
  - Adobe Reader is required to view the operating instructions.

**Note:**

- If you install the operating instructions, you can view it anytime by clicking [ ? ] on the Multi-Function Station launcher.



## 2.1 Printing from Windows applications

You can print a file created in a Windows application. For example, to print from WordPad, proceed as follows.

- 1 Open the document you want to print.
- 2 Select **[Print...]** from the **[File]** menu.
- 3 Select the unit's name as the active printer.
- 4 Click **[Print]** or **[OK]**.
  - The unit will start printing.

## 2.2 Scanning from the unit (Push Scan)

You can easily scan the document by using the operation panel on the unit.

### 2.2.1 Scan to Multi-Function Viewer

- 1 Set the original (page 13).
- 2 **[Scan]**
- 3 Press **[▼]** or **[▲]** repeatedly to select "VIEWER". → **[Set]**
- 4 **For USB connection:**  
Press **[▼]** or **[▲]** repeatedly to select "USB HOST". → **[Set]**  
**For LAN connection:**  
Press **[▼]** or **[▲]** repeatedly to select the computer to which you want to send the scanned image. → **[Set]**
- 5 If necessary, change the scanning settings. Press **[▶]**, press **[▼]** or **[▲]** repeatedly to select the desired setting. → **[Set]** → **[Black]/[Colour]**

## 2.3 Scanning from a computer (Pull Scan)

### 2.3.1 Using Multi-Function scan application

By clicking an application icon, the selected application starts automatically after scanning.

- 1 Set the original (page 13).
- 2 Start Multi-Function Station. → **[Scan]**
- 3 Click the desired application icon.

## 2.4 Making a copy

### 2.4.1 Using the scanner glass

- 1 If the **[Copy]** light is OFF, turn it ON by pressing **[Copy]**.
- 2 Set the original (page 13).
- 3 If necessary, change the resolution and contrast according to the type of document.
- 4 If necessary, enter the number of copies (up to 99).
- 5 **[Black]/[Colour]**
  - The unit will start copying.
- 6 After you finish copying, press **[Stop]** to reset the settings you set in step 3 and 4.

### 2.4.2 Using the automatic document feeder

- 1 If the **[Copy]** light is OFF, turn it ON by pressing **[Copy]**.
- 2 Set the original (page 14).
- 3 If necessary, change the resolution and contrast according to the type of document.
- 4 If necessary, enter the number of copies (up to 99).
- 5 **[Black]/[Colour]**
  - The unit will start copying.
- 6 After you finish copying, press **[Stop]** to reset the settings you set in step 3 and 4.

## 2.5 Sending a fax manually

**Important:**

- You can only send faxes in monochrome.

### 2.5.1 Using the scanner glass

- 1 If the **[Fax]** light is OFF, turn it ON by pressing **[Fax]**.
- 2 Set the original (page 13).
- 3 If necessary, change the resolution and contrast according to the type of document.
- 4 Dial the fax number.
  - To send a single page, skip to step 7.
  - To send multiple pages, go to the next step.
- 5 Press **[Quick Scan]** to scan the document into memory.
- 6 Place the next page on the scanner glass. → **[Set]**
  - To send more pages, repeat this step.
- 7 **[Black]**

## 2. How to Use

### 2.5.2 Using the automatic document feeder

- 1 If the **[Fax]** light is OFF, turn it ON by pressing **[Fax]**.
- 2 Set the original (page 14).
- 3 If necessary, change the resolution and contrast according to the type of document.
- 4 **[Monitor]**
- 5 Dial the fax number. → **[Black]**

## 2.6 Receiving a fax automatically – Auto answer ON

### Important:

- You can only receive faxes in monochrome.

### 2.6.1 Activating FAX ONLY mode

Press **[Fax Auto Answer]** repeatedly to display “**FAX ONLY MODE**”.

### How faxes are received

When receiving calls, the unit will automatically answer all calls and only receive fax documents.

## 2.7 Cancelling the operations

You can cancel the current operation from the unit. You can also select the desired operation to cancel.

- 1 **[Stop]**
  - “**USER STOPPED**” is displayed.
  - When “**USER STOPPED**” is not displayed, go to step 2.
- 2 **To cancel printing:**

Press **[Stop]** repeatedly to display “**STOP PRINTING?**”.

**To cancel scanning:**

Press **[Stop]** repeatedly to display “**STOP SCANNING?**”.

**To cancel copying:**

Press **[Stop]** repeatedly to display “**STOP COPYING?**”.

**To cancel sending or receiving faxes:**

Press **[Stop]** repeatedly to display “**STOP FAX?**”.

**To cancel broadcast transmission:**

Press **[Stop]** repeatedly to display “**BROAD CANCELLED?**”.

**To cancel fax redialling:**

Press **[Stop]** repeatedly to display “**SEND CANCELLED?**”.
- 3 **[Set]**

## 2.8 Maintenance (Cleaning the drum cartridge)

If vertical, white lines appear on the printed documents, print the colour test, then clean (or change) the drum cartridge.

- 1 Press **[Menu]** repeatedly to display “**PRINT REPORT**”.
- 2 Press **[◀]** or **[▶]** repeatedly to display “**COLOUR TEST**”.
- 3 Press **[Set]** to start printing. → **[Menu]**

### Colour test

The unit will print a colour test page consisting of black, cyan, magenta and yellow lines so you can specify which drum cartridge has the problem.

If vertical, white lines appear on the colour test page, try the following to solve the problem.

### Solution 1: Cleaning the drum cartridge

#### Important:

- This solution uses at least 3 pages of recording paper. Make sure there is enough recording paper installed in the standard input tray beforehand.

1. **[Menu]** → **[#][4][8][0]**
2. Select the colour which has vertical, white lines in the colour test page.
  - [1]** “**BLACK**” (default)
  - [2]** “**CYAN**”
  - [3]** “**MAGENTA**”
  - [4]** “**YELLOW**”
3. **[Set]**
  - The drum cartridge will be cleaned automatically by printing out 3 pages of the selected colour.
  - Repeat steps 1 to 3 for all lines with vertical, white lines.
  - Print the colour test again. If the vertical, white lines remain, try the next solution.

### Solution 2: Changing the drum cartridge

- If the black test page has vertical, white lines, change the monochrome drum cartridge.
- If the cyan, magenta or yellow test page has vertical, white lines, change the colour drum cartridge.
- Print the colour test again. If the vertical, white lines remain, contact our service personnel.

## 3.1 Error messages – Display

If the unit detects a problem, one or more of the following messages will appear on the display.

Display	Cause & Solution
“BLACK TONER EMPTY” “CYAN TONER EMPTY” “MAGENTA TONER EMPTY” “YELLOW TONER EMPTY” ↓ “CHANGE SUPPLIES”	<ul style="list-style-type: none"> <li>● The toner cartridge life is finished. Replace the toner cartridge immediately.</li> </ul>
“BLACK TONER LOW” “CYAN TONER LOW” “MAGENTA TONER LOW” “YELLOW TONER LOW” ↓ “CHANGE SUPPLIES”	<ul style="list-style-type: none"> <li>● The toner cartridge life is near its end. Replace the toner cartridge as soon as possible.</li> </ul>
“CALL SERVICE”	<ul style="list-style-type: none"> <li>● There is something wrong with the unit. Contact our service personnel.</li> </ul>
“CHECK DOCUMENT”	<ul style="list-style-type: none"> <li>● The document was not fed into the unit properly. Remove the document, then press <b>[Stop]</b> to clear the message. Re-insert the document. If misfeeding occurs frequently, clean the document feeder rollers and try again.</li> </ul>
“CHECK INSTALL INPUT TRAY #1”	<ul style="list-style-type: none"> <li>● The paper input tray is not installed correctly. Pull out the paper input tray and re-insert it.</li> </ul> <p><b>Note:</b></p> <ul style="list-style-type: none"> <li>● “#1”: Standard input tray</li> <li>● “#2”: Optional input tray</li> <li>● “#1+#2”: Standard input tray and optional input tray</li> </ul>
“CHECK PAPER”	<ul style="list-style-type: none"> <li>● You are printing on envelopes. Check the standard input tray to be sure that envelopes are installed, then press <b>[Black]/[Colour]</b>.</li> <li>● The recording paper size is not the same as the size selected for copy. Change the recording paper size setting (feature #380 or feature #382), and install the appropriate recording paper.</li> <li>● The recording paper size is not the same as the size selected when printing from the PC. Change the recording paper size setting (feature #380 or feature #382), and install the appropriate recording paper.</li> <li>● The recording paper size is not the same as the size selected for receiving a fax. Change the recording paper size setting (feature #380 or feature #382), and install the appropriate recording paper.</li> </ul>
“CHECK PICK UP INPUT TRAY #1”	<ul style="list-style-type: none"> <li>● Recording paper was not fed into the unit properly. Re-insert the recording paper.</li> </ul> <p><b>Note:</b></p> <ul style="list-style-type: none"> <li>● “#1”: Standard input tray</li> <li>● “#2”: Optional input tray</li> </ul>
“COLOUR DRUM REPLACE” “MONOCHROME DRUM REPLACE” ↓ “CHANGE SUPPLIES”	<ul style="list-style-type: none"> <li>● The drum cartridge life is finished. Replace the drum cartridge immediately.</li> </ul> <p><b>Note:</b></p> <ul style="list-style-type: none"> <li>● The continuous use of an old drum cartridge may cause malfunction. To prevent this, when the drum life is finished, the unit will stop printing after a while, and printing will not be possible until a new drum cartridge is installed.</li> </ul>

### 3. Help

Display	Cause & Solution
"COLOUR DRUM LIFE LOW" "MONOCHROME DRUM LIFE LOW" ↓ "CHANGE SUPPLIES"	<ul style="list-style-type: none"> <li>The drum cartridge life is near its end. Replace the drum cartridge as soon as possible.</li> </ul>
"COOL DOWN FUSER"	<ul style="list-style-type: none"> <li>The unit is cooling down the fuser unit. Wait for a while.</li> </ul>
"DIRECTORY FULL"	<ul style="list-style-type: none"> <li>There is no space to store new items in navigator directory. Erase unnecessary items.</li> </ul>
"DRUM NOT INSTALLED"	<ul style="list-style-type: none"> <li>The colour drum cartridge or the monochrome drum cartridge is not installed. Install it.</li> </ul>
"E-MAIL SIZE OVER"	<ul style="list-style-type: none"> <li>When performing scan to e-mail server, the total file size of scanned data exceeded the file size limitation. Divide the document into sections.</li> </ul>
"FAX IN MEMORY"	<ul style="list-style-type: none"> <li>The unit has a document in memory. See the other displayed message instructions to print out the document.</li> <li>If feature #442 is set to "ALWAYS",               <ul style="list-style-type: none"> <li>check the connection between the computer and the unit.</li> <li>check the computer is turned ON.</li> </ul> </li> </ul>
"FILE SIZE OVER"	<ul style="list-style-type: none"> <li>When performing scan to FTP server, the total file size of scanned data exceeded the file size limitation. Divide the document into sections.</li> </ul>
"FRONT OR LEFT COVER OPEN"	<ul style="list-style-type: none"> <li>The front or left cover is open. Close it.</li> </ul>
"KEEP COPYING"	<ul style="list-style-type: none"> <li>Copying has stopped due to some existing problem (example: a lack of recording paper or a recording paper jam). See the other displayed message instructions to continue copying.</li> </ul>
"LOW TEMP."	<ul style="list-style-type: none"> <li>The inside of the unit is extremely cold and cannot be operated. Use the unit in a warmer area.</li> </ul>
"MEMORY FULL"	<ul style="list-style-type: none"> <li>When performing memory transmission, the document being stored exceeded the memory capacity of the unit. Send the entire document manually.</li> <li>When making a copy, the document being stored exceeded the memory capacity of the unit. Press <b>[Stop]</b> to clear the message. Divide the document into sections.</li> </ul>
"MODEM ERROR"	<ul style="list-style-type: none"> <li>There is something wrong with the unit's modem. Contact our service personnel.</li> </ul>
"NO FAX REPLY"	<ul style="list-style-type: none"> <li>The other party's fax machine is busy or has run out of recording paper. Try again.</li> </ul>
"OUT OF PAPER INPUT TRAY #1"	<ul style="list-style-type: none"> <li>Recording paper is not installed or the paper input tray has run out of paper. Install paper.</li> <li>Recording paper is not fed into the unit properly. Reinstall paper.</li> </ul> <p><b>Note:</b></p> <ul style="list-style-type: none"> <li>"#1": Standard input tray</li> <li>"#2": Optional input tray</li> <li>"#1+#2": Standard input tray and optional input tray</li> </ul>
"PAPER JAMMED"	<ul style="list-style-type: none"> <li>A recording paper jam occurred. See the other displayed message instructions to remove the jammed paper.</li> </ul>

Display	Cause & Solution
“PC FAIL OR BUSY”	<ul style="list-style-type: none"> <li>● The cable or the computer power cord is not connected correctly. Check the connections.</li> <li>● The software is not running on the computer. Restart the software and try again.</li> </ul>
“PLEASE WAIT”	<ul style="list-style-type: none"> <li>● The unit is warming up. Wait for a while.</li> </ul>
“POLLING ERROR”	<ul style="list-style-type: none"> <li>● The other party’s fax machine does not offer the polling function. Check with the other party.</li> </ul>
“REDIAL TIME OUT”	<ul style="list-style-type: none"> <li>● The other party’s fax machine is busy or has run out of recording paper. Try again.</li> </ul>
“REMOVE DOCUMENT”	<ul style="list-style-type: none"> <li>● The document is jammed. Remove the jammed document.</li> <li>● Attempted to send or copy a document longer than 600 mm using the automatic document feeder. Press <b>[Stop]</b> to remove the document. Divide the document into two or more sheets and try again.</li> </ul>
“RX MEMORY FULL”	<ul style="list-style-type: none"> <li>● The memory is full of received documents due to a lack of recording paper or a recording paper jam. Install paper or remove the jammed paper.</li> <li>● If feature #442 is set to “ALWAYS”, <ul style="list-style-type: none"> <li>– check the connection between the computer and the unit.</li> <li>– check the computer is turned ON.</li> </ul> </li> </ul>
“SCANNER POSITION ERROR”	<ul style="list-style-type: none"> <li>● There is something wrong with the scanner position. Turn the power switch OFF, then ON. If the problem cannot be solved, contact our service personnel.</li> </ul>
“SELF CALIBRATION”	<ul style="list-style-type: none"> <li>● The unit is changing the colour calibration. Wait for a while.</li> </ul>
“TRANSMIT ERROR”	<ul style="list-style-type: none"> <li>● A transmission error occurred. Try again.</li> </ul>
“TONER CARTRIDGE NOT INSTALLED”	<ul style="list-style-type: none"> <li>● The toner cartridge is not installed. Install it.</li> </ul>
“TRAY #2 LEFT COVER OPEN”	<ul style="list-style-type: none"> <li>● The left cover of the optional input tray is open. Close it.</li> </ul>
“WASTE TONER FULL” ↓ “CHANGE SUPPLIES”	<ul style="list-style-type: none"> <li>● The waste toner cartridge life is near its end. Replace the waste toner cartridge as soon as possible.</li> </ul>
“WASTE TONER NOT INSTALLED”	<ul style="list-style-type: none"> <li>● The waste toner cartridge is not installed. Install it.</li> </ul>
“WASTE TONER REPLACE” ↓ “CHANGE SUPPLIES”	<ul style="list-style-type: none"> <li>● The waste toner cartridge life is finished. Replace the waste toner cartridge immediately.</li> </ul>

---

## Notes

---

## Notes

**Note for Australian users:**

- Panasonic Australia operates a toll free Customer Care Centre. Please visit the website for assistance at <<http://www.panasonic.com.au>> or please call 132600.

**Note for New Zealand users:**

- Panasonic New Zealand operates a Customer Support Centre. Please call (09) 2720178 for assistance.



**Sales Department:**

**Panasonic Australia Pty. Limited**

Austlink Corporate Park, 1 Garigal Road, Belrose, NSW 2085, Australia

**Panasonic New Zealand Limited**

350 Te Irirangi Drive, East Tamaki, Private Bag 14911, Panmure, Auckland, New Zealand

**Manufacturer:**

**Panasonic Communications Co., Ltd.**

1-62, 4-chome, Minoshima, Hakata-ku, Fukuoka 812-8531, Japan

**Global web site:**

<http://panasonic.net>



\*MC6020CX\*