



Loudspeaker Systems



XLS360•XLS340•XLS320•XCS350
Owner's Manual



WARNING - TO REDUCE RISK OF FIRE OR ELECTRICAL SHOCK, DO NOT EXPOSE THIS EQUIPMENT TO RAIN OR MOISTURE.

NO USER-SERVICEABLE PARTS INSIDE. REFER SERVICING TO QUALIFIED PERSONNEL.

To prevent the risk of electric shock, do not remove cover or back. No user serviceable parts inside.

IMPORTANT SAFETY INSTRUCTIONS!

PLEASE READ THEM BEFORE OPERATING THIS EQUIPMENT.

1. Read these instructions.
2. Keep these instructions.
3. Heed all warnings.
4. Follow all instructions.
5. Do not use this apparatus near water.
6. Clean only with a dry cloth.
7. Install in accordance with the manufacturer's instructions.
8. This apparatus is capable of producing high sound pressure levels. Continued exposure to high sound pressure levels can cause permanent hearing impairment or loss. User caution is advised and ear protection is recommended when playing at high volumes.
9. Do not install near any heat sources such as radiators, heat registers, stoves, or other apparatus (including amplifiers) that produce heat.
10. Only use attachments/accessories specified by the manufacturer.
11. Use only with the cart, stand, tripod, bracket, or table specified by the manufacturer, or sold with the apparatus. When a cart is used, use caution when moving the cart/apparatus combination to avoid injury from tip-over.
12. Refer all servicing to qualified service personnel. Servicing is required when the apparatus has been damaged in any way, liquid has been spilled or objects have fallen into the apparatus, the apparatus has been exposed to rain or moisture, does not operate normally, or has been dropped.
13. Do not expose this equipment to dripping or splashing and ensure that no objects filled with liquids, such as vases, are placed on the equipment.



Thank You

Your decision to own a McIntosh Loudspeaker System ranks you at the very top among discriminating music listeners. You now have “The Best.” The McIntosh dedication to “Quality,” is assurance that you will receive many years of musical enjoyment from this unit.

Please take a short time to read the information in this manual. We want you to be as familiar as possible with all the features and functions of your new McIntosh.

Please Take A Moment

The serial number, purchase date and McIntosh Dealer name are important to you for possible insurance claim or future service. The spaces below have been provided for you to record that information:

Serial Number: _____

Purchase Date: _____

Dealer Name: _____

Technical Assistance

If at any time you have questions about your McIntosh product, contact your McIntosh Dealer who is familiar with your McIntosh equipment and any other brands that may be part of your system. If you or your Dealer wish additional help concerning a suspected problem, you can receive technical assistance for all McIntosh products at:

McIntosh Laboratory, Inc.
2 Chambers Street
Binghamton, New York 13903
Phone: 607-723-1545
Fax: 607-772-3308

Customer Service

If it is determined that your McIntosh product is in need of repair, you can return it to your Dealer. You can also return it to the McIntosh Laboratory Service Department. For assistance on factory repair return procedure, contact the McIntosh Service Department at:

McIntosh Laboratory, Inc.
2 Chambers Street
Binghamton, New York 13903
Phone: 607-723-3515
Fax: 607-723-1917

Table of Contents

Safety Instructions	2
Thank You and Please Take a Moment.....	3
Technical Assistance and Customer Service	3
Table of Contents	3
Important Information	4
Introduction	4
Performance Features	5
Dimensions:	
XLS320	6
XLS340	7
XLS360	8
XCS350	9
Installation:	
Installation Overview	10
Unpacking the XLS320	10
Unpacking the XLS340	10
Unpacking the XLS360	11
Unpacking the XCS350	12
Wall Mounting the XLS320.....	13
Wall Mounting the XLS340.....	14
Wall Mounting the XCS350	16
Locating the Loudspeaker	18
Tweeter Array Optimization	19
Connections:	
Connecting the XLS320 (default setting)	20
Connecting the XLS320 (optional setting)	21
Connecting the XLS340, XLS360 and XCS350 (with one amplifier)	22
Connecting the XLS340, XLS360 and XCS350 (with two amplifiers)	23
Specifications:	
XLS320	24
XLS340	24
XLS360	25
XCS350	25
Packing Instructions:	
XLS320	26
XLS340	26
XLS360	27
XCS350	27



Important Information

Caution: *The XLS360 Loudspeaker weight is 107 pounds (48.5kg) net. It requires two or more persons to handle safely.*

- Loudspeaker Cables of adequate size are important to ensure that there will be no significant power loss or heating. Cable size is specified in Gauge numbers or AWG (American Wire Gauge). The smaller the Gauge number, the larger the wire size:
If the Loudspeaker Cables are 25 feet (7.62m) or less, use at least 16 Gauge (AWG) wire size or larger.
If the Loudspeaker Cables are 50 feet (15.24m) or less, use at least 14 Gauge (AWG) wire size or larger.
If the Loudspeaker Cables are 100 feet (30.48m) or less, use at least 12 Gauge (AWG) wire size or larger.
The Loudspeaker Connection Terminals can accept up to 12 Gauge (AWG) wire.*
- For additional connection information, refer to the owner's manual(s) for any component(s) connected to the XLS320, XLS340, XLS360 or XCS350 Loudspeaker.*
- The XLS and XCS Loudspeaker Systems have built-in automatic resetting solid-state devices in the crossover networks for protection. The protection allows a certain amount of overdrive, however extended periods of overdrive will trigger protection. If an obvious lack of high, mid or low frequencies is noticed, the Protection Device may have activated. These devices will automatically reset when the volume level is reduced significantly and kept low until the output of the affected Loudspeaker Element returns to normal.*
- When the XLS340, XLS360 or XCS350 Loudspeaker Systems are driven by more than one amplifier, the output levels of the different amplifiers connected to the Loudspeaker System must be adjusted to achieve a proper balance between the low, midrange/high frequencies reproduced. This adjustment is best achieved through the use of audio test equipment operated by a qualified installer.*

Introduction

The McIntosh XLS320, XLS340, XLS360 and XCS350 Loudspeaker Systems are designed for Home Theater and Music Reproduction. Many of today's Loudspeakers are designed only for Home Theater applications, not so with these Loudspeaker Systems. They are also designed for the accurate reproduction of music.

Motion picture sound effects, explosions, screams, and vehicle crashes require a wide dynamic range and high sound levels. These sounds are such that a speaker system having moderate distortion would reproduce them with little audible difference. This is not true with the reproduction of music. Music is by nature and definition harmonious. To reproduce it accurately, all forms of distortion, both harmonic and intermodulation, must be kept to a minimum. This has been the result of the design of the new McIntosh XLS320, XLS340, XLS360 and XCS350 Loudspeaker Systems. Each loudspeaker element and crossover component has been carefully designed for low distortion, durability and efficiency. The McIntosh XLS320, XLS340, XLS360 and XCS350 Loudspeaker System will reproduce music accurately and function as an excellent Home Theater Loudspeaker.

The XLS320 is a two-way system with a 6-1/2 inch LD/HP¹ woofer/midrange driver and five 1 inch dome tweeters in a Bessel Function Array. The XLS340 is a three-way system consisting of two 8 inch LD/HP woofers, one 6-1/2 inch LD/HP midrange driver and five 1 inch dome tweeters in a Bessel Function Array. The XLS360 is also a three-way system with two 10 inch LD/HP woofers, one 6-1/2 inch LD/HP midrange driver and five 1 inch dome tweeters in a Bessel Function Array. The XCS350 Center Channel Loudspeaker utilizes two 8 inch LD/HP woofers, one 6-1/2 inch LD/HP midrange driver and five 1 inch dome tweeters in a Bessel Function Array.

The XLS320, XLS340, XLS360 and XCS350 Loudspeaker performance is designed to complement the capabilities of McIntosh's legendary line of Preamplifiers/Control Centers, Signal Sources Devices and Power Amplifiers, without imparting distortion or coloration.

¹LD/HP Pat. No. 5,151,943

Performance Features

- **Patented LD/HP Technology**

The McIntosh Low Frequency and Midrange Loudspeaker Elements feature the patented LD/HP motor structure. This design, when compared to conventional Loudspeaker Elements, reduces distortion significantly. It also increases power handling and efficiency.

- **Five Tweeter Bessel Function Array**

The XLS320, XLS340, XLS360 and XCS350 utilizes five tweeters connected to produce a Bessel Function Array. The individual tweeter amplitudes and phase relationships are adjusted so the array acts as a high frequency point source. One advantage of such an arrangement is a very smooth and even acoustic polar response. This allows the listener to move off axis without suffering a change in high frequency output. The use of multiple tweeters, combined with a mechanical heat sink, also provides greatly increased power handling at high frequencies.

- **Mirror Image Phasing High Frequency Array**

The five tweeter Bessel Function Array utilizes a unique circuit design permitting the optimization of high frequency dispersion for Mirror Imaging. This allows for Loudspeaker placement in a room as the Left Channel, Center Channel or Right Channel for use in a multi-channel system.

- **Shielded Magnetic Field**

The XLS320, XLS340, XLS360 and XCS350 may be used in Home Theater Installations near a television receiver or monitor without causing the television image to degrade. McIntosh has designed special shielding around the magnetic structure of the XLS320, XLS340, XLS360 and XCS350 Loudspeaker Elements to prevent interference.

- **Special Crossover Network**

The Crossover Networks used in the XLS320, XLS340, XLS360 and XCS350 Loudspeaker Systems are designed to ensure an even frequency response over the entire audible range. The Network utilizes First, Second and Third Order design for optimal response.

- **High Power Handling**

The Loudspeaker Elements and crossover components of the XLS320, XLS340, XLS360 and XCS350 are all chosen for use with powerful amplifiers up to 600 watts.

- **High Efficiency**

The Loudspeaker Elements used in the XLS320, XLS340, XLS360 and XCS350 Loudspeaker Systems have also been designed for high efficiency. As a result any McIntosh Power Amplifier, even our smallest, will provide satisfying room filling sound.

- **Automatic Overload Protection**

The XLS320, XLS340, XLS360 and XCS350 have built-in Loudspeaker Element Protection in the form of automatic resetting solid-state devices as a part of the crossover network.

- **Gold Plated Input Connectors**

The XLS320, XLS340, XLS360 and XCS350 input connectors are gold plated for superior corrosion resistance and high electrical conductivity.

- **Rigid Column Structure**

The enclosures are an important part of the XLS320, XLS340, XLS360 and XCS350 Loudspeaker Systems. The Systems utilize a dampened rigid enclosure made from extruded aluminum and houses the Loudspeaker Drivers and Crossover. The XLS340 and XLS360 Columns, due to their height, have additional front to back internal bracing to form a dampened rigid Column Structure. The Column's small footprint allows for a variety of different placements in a room.



Dimensions

The following dimensions can assist in determining the best location for the XLS320 or XLS340 Loudspeaker System. There is additional information on page 18 pertaining to installing the Loudspeaker.

**Front View of XLS320
with Grille Removed**

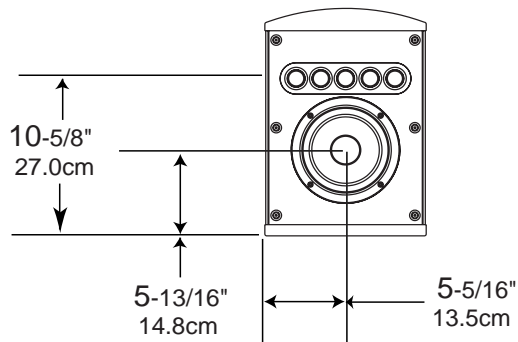

Rear View of XLS320

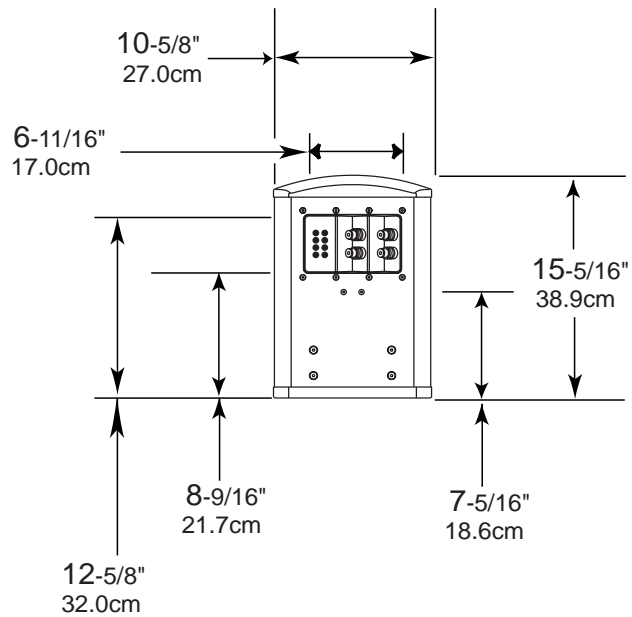

Side View of XLS320

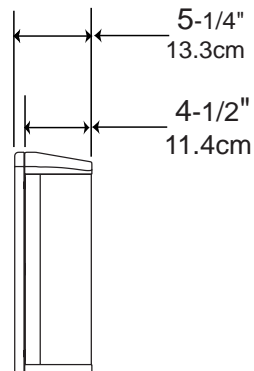

Front View of XLS340 with Grille Removed

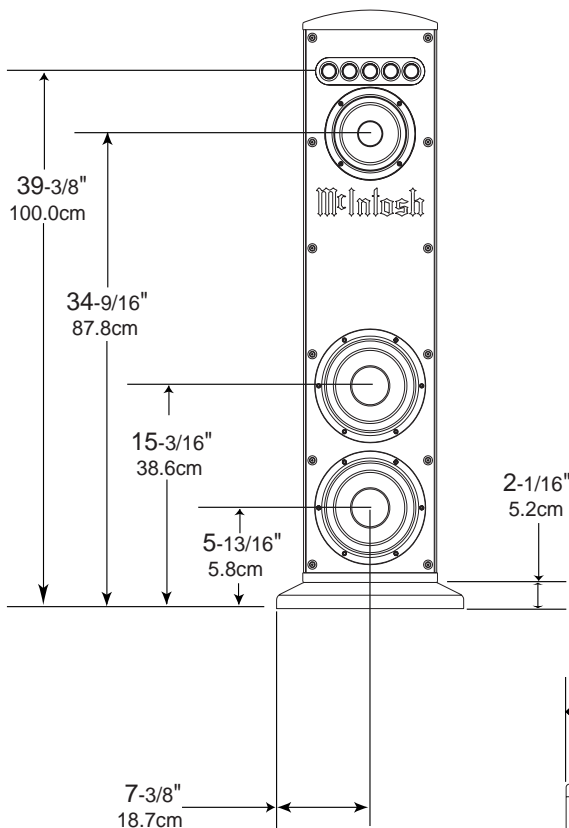

Rear View of XLS340

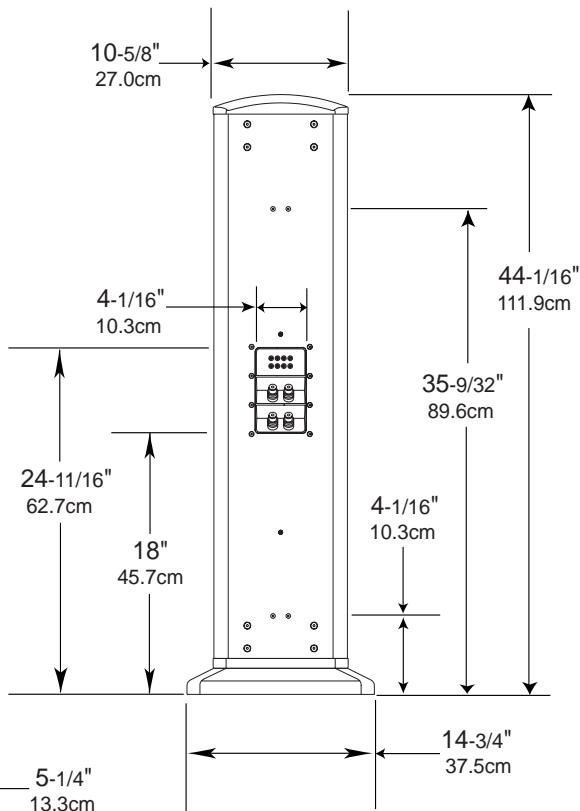

Side View of XLS340

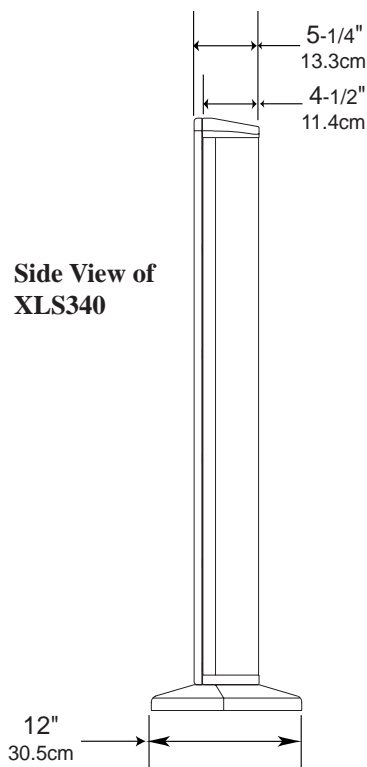

Note: The XLS340 is supplied with optional adjustable feet, four Tiptoes and four Glides. If they are used with the XLS340 please allow for the added height.



Dimensions, con't

The following dimensions can assist in determining the best location for the XLS360 or XCS350 Loudspeaker System. There is additional information on page 18 pertaining to installing the Loudspeaker.

Front View of XLS360 with Grille Removed

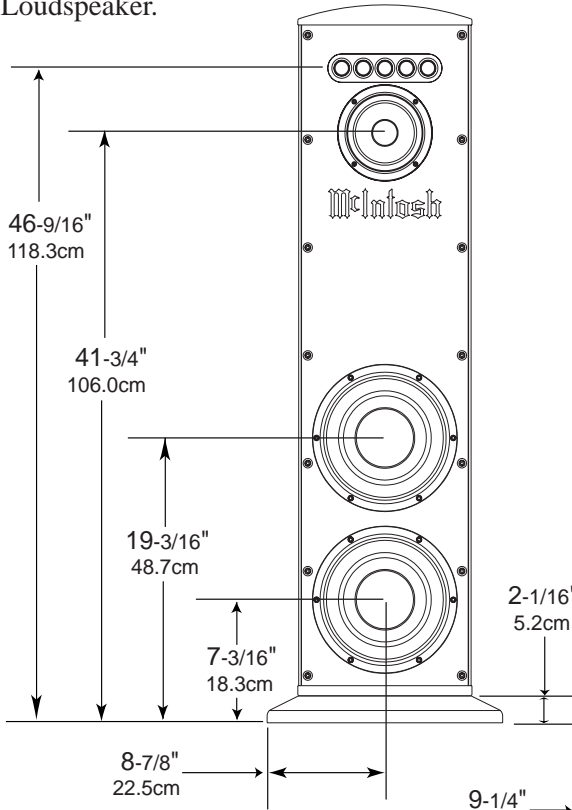

Rear View of XLS360

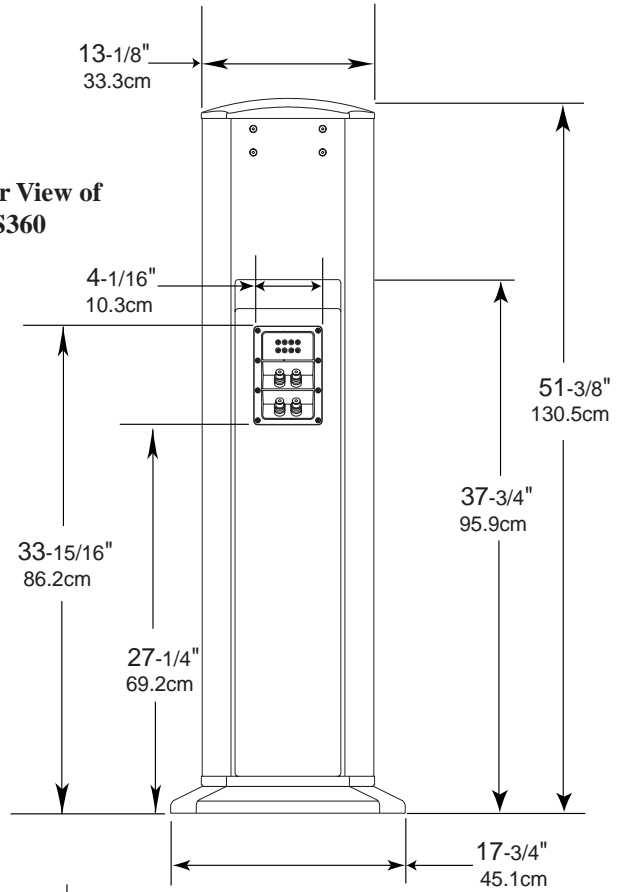

Side View of XLS360

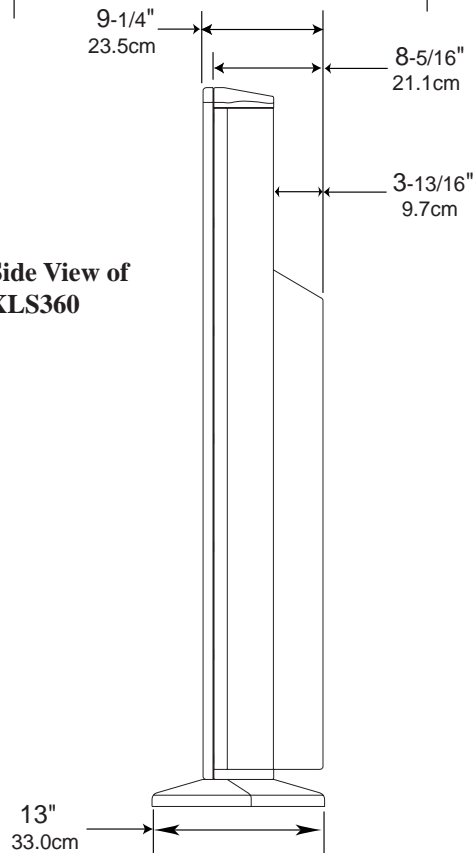

Note: The XLS360 is supplied with optional adjustable feet, four Tiptoes and four Glides. If they are used with the XLS360 please allow for the added height.

Note: The XCS350 is supplied with an adjustable Stabilizer Bar. Please allow for various height/angle.

Front View of XCS350 with Grille Removed

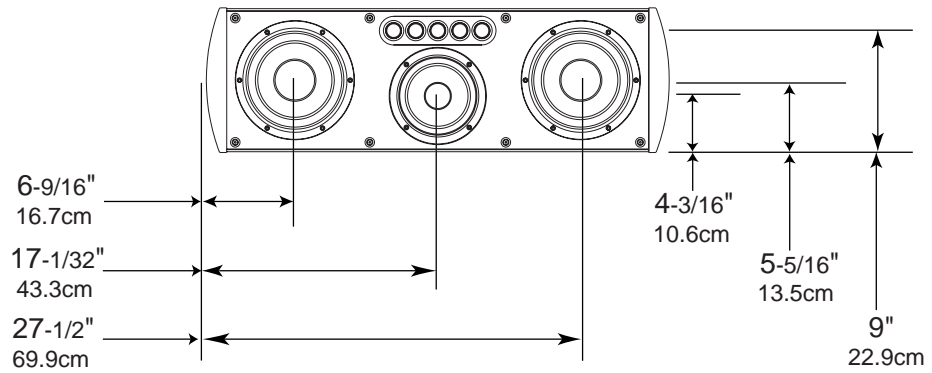

Rear View of XCS350 with the stabilizer bar removed

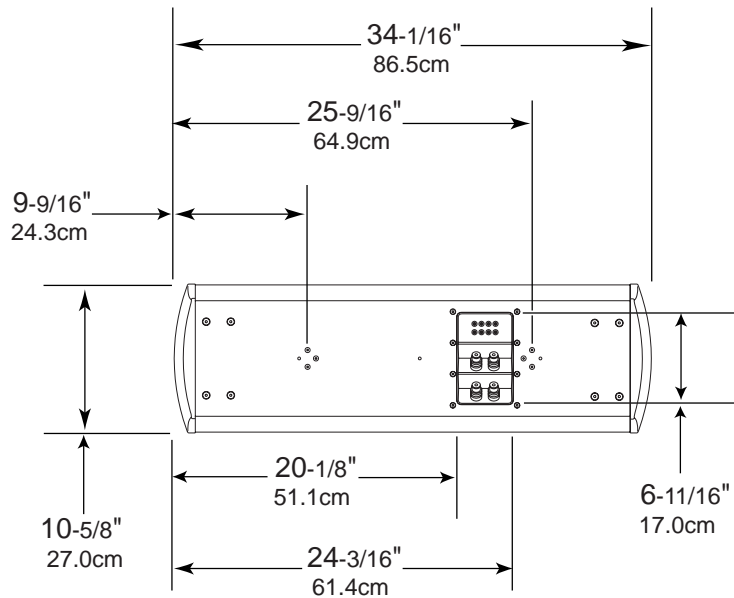

Top View of XCS350

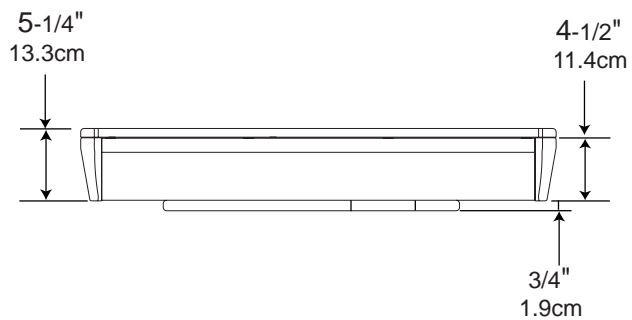



Installation

Installation Overview

The instructions that follow are for the unpacking, assembly and setup of the XLS320, XLS340, XLS360 and XCS350 Loudspeaker Systems as supplied. For several models, an optional In Wall Mounting Kit is available. If the Loudspeaker is to be Mounted On or In Wall, refer to “Locating the Loudspeaker System” on page 18, “Tweeter Array Optimization” on page 19 and “How to Connect” starting on page 20, before beginning the Mounting Process. For additional information on the different types of installation, refer to figure 1.

Caution: The XLS360 Loudspeaker weight is 107 pounds (48.5kg) net and requires two or more persons to safely handle during unpacking, assembly and placement.

It is recommended that the Professionals at your McIntosh Dealer, who are skilled in all aspects of installation and operation, install the Loudspeaker System and any associated audio/video equipment.

Unpacking the XLS320 Loudspeaker

1. Remove the entire assembly (Loudspeaker System, Loudspeaker Grille and foam end caps) by lifting up on the bottom of the assembly (Loudspeaker rear) and place it along side the shipping carton on a flat surface.
2. Release the Loudspeaker Grille from the foam end caps and remove it from the protective plastic shipping film and set it aside.
3. In a similar manner, lift out the Loudspeaker System.
4. Close the top flaps of the shipping carton and place the two foam end caps on top of the carton.
5. Carefully remove the protective plastic shipping film from the Loudspeaker System so as not to mar the finish or damage the Loudspeaker System Drivers.

Notes: 1. The XLS320 Loudspeaker is supplied with an On Wall Mounting Bracket and Hardware. If the XLS320 is to be mounted on the wall at this time, proceed to “How to Mount the XLS320 Loudspeaker On the Wall” on page 13.

2. When the optional In Wall Mounting Kit is chosen, refer to the supplied installation guide.

6. Place the Loudspeaker System, with the front facing up, on foam end caps located on top of the shipping

carton. Refer to figure 2.

7. Orient the Loudspeaker and the Grille with the rounded ends pointing in the same direction.

8. Align the Grille fasteners to the Loudspeaker Grommets (two on each side). Carefully push down to secure the Grille to the Loudspeaker.

9. Proceed to “Locating the Loudspeaker System” on page 18.

10. Proceed to “Locating the Loudspeaker System” on page 18.

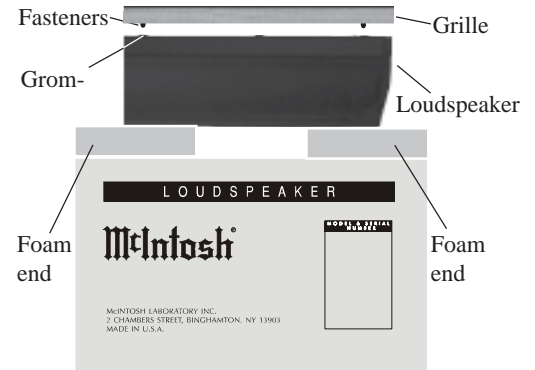

Figure 2

Unpacking the XLS340 Loudspeaker

1. Remove the entire assembly (Loudspeaker System, Loudspeaker Grille and foam end caps) by lifting up on the bottom of the assembly (Loudspeaker rear) and place it along side the shipping carton on a flat surface.
2. Release the Loudspeaker Grille from the foam end caps and remove it from the protective plastic shipping film and set it aside.
3. In a similar manner, lift out the Loudspeaker System.
4. Close the top flaps of the shipping carton and place the two foam end caps on top of the carton.
5. Carefully remove the protective plastic shipping film from the Loudspeaker System so as not to mar the finish or damage the Loudspeaker System Drivers.

Notes: 1. When the XLS340 is to be used with the supplied Floor Standing Base and Hardware, proceed to step 6.

2. The XLS340 Loudspeaker is also supplied with On Wall Mounting Brackets and Hardware. If the XLS340 is to be mounted on the wall at this time, proceed to “How to Mount the XLS340 Loudspeakers On the Wall” on page 14.

3. When the optional In Wall Mounting Kit is chosen, refer to the supplied installation guide.

Installation Methods				
Loudspeaker Model	Floor Base	Stabilizer Bar	On Wall Mounting Kit	In Wall Mounting Kit
XLS320	----	----	Supplied	Optional
XLS340	Supplied	----	Supplied	Optional
XLS360	Supplied	----	----	----
XCS350	----	Supplied	Supplied	Optional

Figure 1

- Place the Loudspeaker System, with the front facing up, on foam end caps located on top of the shipping carton, with the bottom of the XLS340 overhanging the end of the shipping carton. Refer to figure 3.

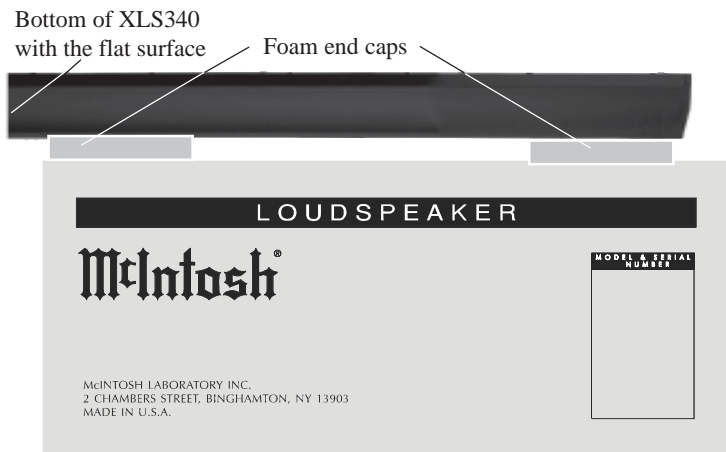

Figure 3

- Using the supplied Allen Wrench, remove four screws from the XLS340 Bottom. Refer to figure 4.

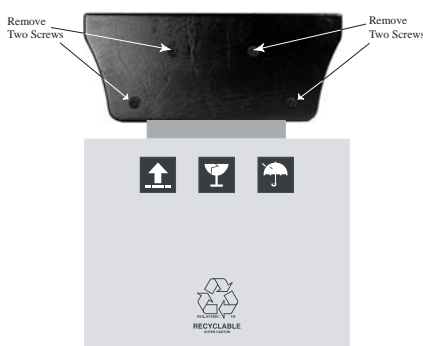

Figure 4

- Unpack the Floor Standing Base from the other shipping carton.
- Orient the Floor Standing Base with the widest end of the base facing up and the totally flat side of the base pointing away from the XLS340. Refer to figure 5.
- Attach the Floor Standing Base to the XLS340 using the four supplied machine bolts and washers.

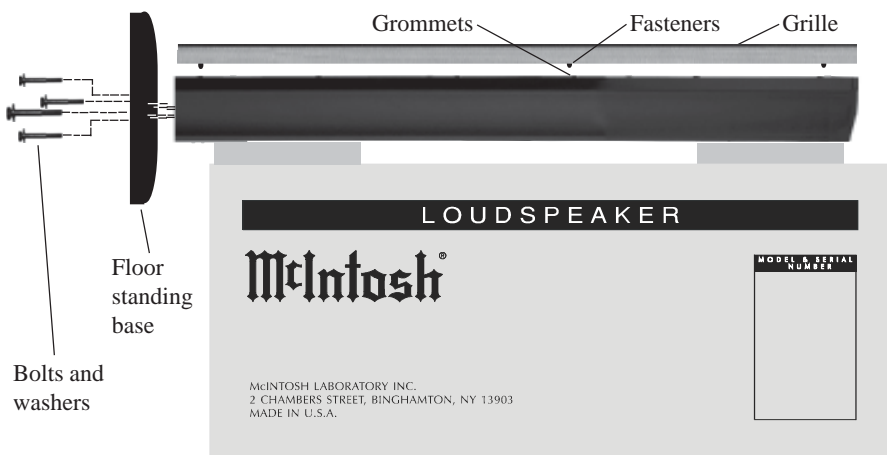
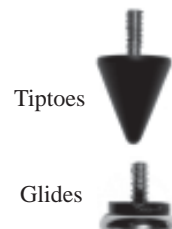

Figure 5

- Orient the Loudspeaker and the Grille with the rounded ends pointing in the same direction.
- Align the Grille fasteners to the Loudspeaker Grommets (three on each side). Carefully push down to secure the Grille to the Loudspeaker.

Note: There are four Tiptoes and Glides supplied with the XLS340. To prevent crushing carpet use the Tiptoe spikes; to protect non-carpeted flooring use the chrome Glides. Both the Glides and Tiptoes have a threaded shaft and locking nut that screw into the tapped holes in the bottom of the Floor Standing Base. The feet can be independently adjusted to compensate for uneven flooring.



- Proceed to "Locating the Loudspeaker System" on page 18.

Unpacking the XLS360 Loudspeaker

- Remove the entire assembly (Loudspeaker System, Loudspeaker Grille and foam center/end caps) by lifting up on the bottom of the assembly (Loudspeaker rear) and place it along side the shipping carton on a flat surface.
- Release the Loudspeaker Grille from the foam center/end caps and remove it from the protective plastic shipping film and set it aside.
- In a similar manner, lift out the Loudspeaker System.
- Replace the shipping carton top onto the shipping carton bottom. Place one foam end cap and one foam center cap on top of the carton. Refer to figure 6 on the next page.
- Carefully remove the protective plastic shipping film from the Loudspeaker System so as not to mar the finish or damage the Loudspeaker System Drivers.

Note: The XLS360 is a sealed Acoustic System. If it is to be used without the supplied Floor Standing Base attached to the bottom, the four unused holes on the bottom of the loudspeaker need to be plugged up with suitable material to prevent air leaks. Proceed to step 10 if the Floor Standing Base is not used.

- Place the Loudspeaker System, with the front facing up, on foam end caps located on top of the shipping carton, with the bottom of the XLS360 overhanging the end of the shipping carton. Refer to figure 6 on the next page.
- Unpack the Floor Standing Base from the other shipping carton.



Installation, con't

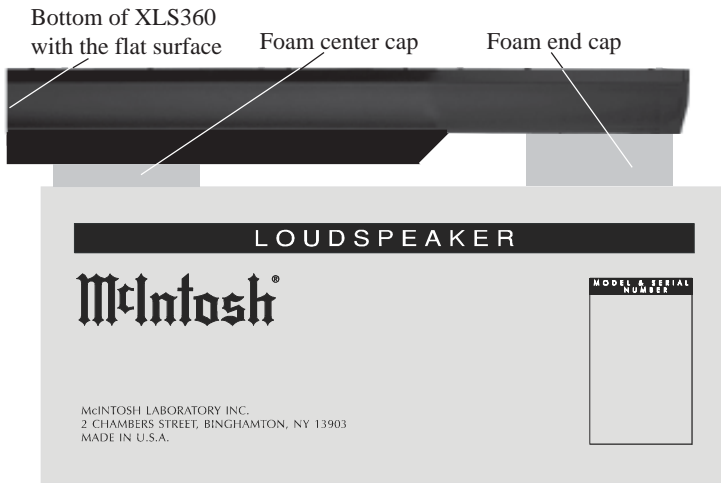

Figure 6

8. Orient the Floor Standing Base with the widest end of the base facing up and the totally flat side of the base pointing away from the XLS360. Refer to figure 7.

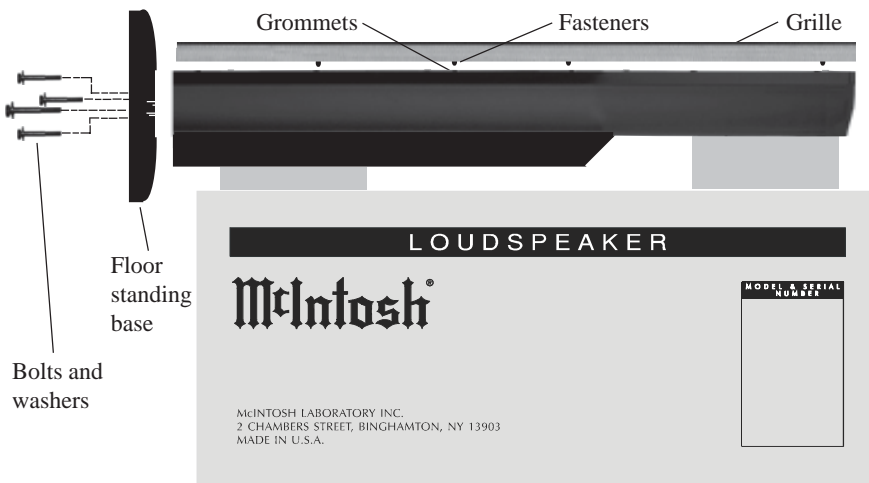
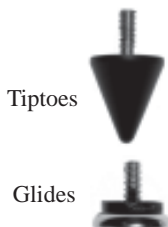

Figure 7

9. Attach the Floor Standing Base to the XLS360 using the four supplied machine bolts and washers.
10. Orient the Loudspeaker and the Grille with the rounded ends pointing in the same direction.
11. Align the Grille fasteners to the Loudspeaker Grommets (four on each side). Carefully push down to secure the Grille to the Loudspeaker.

Note: There are four Tiptoes and Glides supplied with the XLS360. To prevent crushing carpet use the Tiptoe spikes; to protect non-carpeted flooring use the chrome Glides. Both the Glides and Tiptoes have a threaded shaft and locking nut that screw into the tapped holes in the bottom of the Floor Standing Base. The feet can be



independently adjusted to compensate for uneven flooring.

12. Proceed to “Locating the Loudspeaker System” on page 18.

Unpacking the XCS350 Loudspeaker

1. Remove the entire assembly (Loudspeaker System, Loudspeaker Grille and foam end caps) by lifting up on the bottom of the assembly (Loudspeaker rear) and place it along side the shipping carton on a flat surface.
2. Release the Loudspeaker Grille from the foam end caps and remove it from the protective plastic shipping film and set it aside.
3. In a similar manner, lift out the Loudspeaker System.
4. Close the top flaps of the shipping carton and place the two foam end caps on top of the carton.
5. Carefully remove the protective plastic shipping film from the Loudspeaker System so as not to mar the finish or damage the Loudspeaker System Drivers.

Notes: 1. When the XCS350 is to be used with the supplied Stabilizer Bar and Hardware, proceed to step 6.

2. The XCS350 Loudspeaker is also supplied with On Wall Mounting Brackets and Hardware. If the XCS350 is to be mounted on the wall at this time, proceed to “How to Mount the XCS350 Loudspeakers On the Wall” on page 16.

3. When the optional In Wall Mounting Kit is chosen, refer to the supplied installation guide.

6. Place the Loudspeaker System, with the front facing down, on foam end caps located on top of the shipping carton. Refer to figure 8.

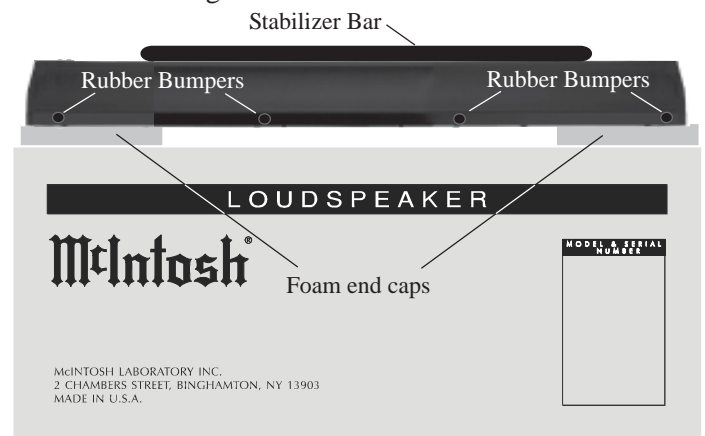

Figure 8

7. Attach the four rubber bumpers to the bottom long edge of the XCS350 Loudspeaker System. Refer to figure 8.
8. Loosen, but do not remove, the three screws securing the Stabilizer Bar to the back of the XCS350. Refer to figure 9.

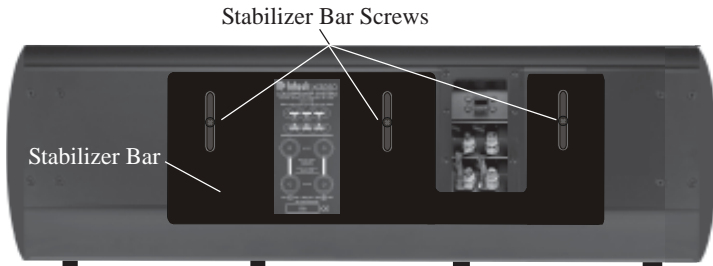

Figure 9

9. Reposition the Stabilizer Bar even with the previously applied rubber bumpers on the side edge of the XCS350 enclosure. Refer to figure 10.



Figure 10

10. Tighten the three screws securing the Stabilizer Bar to keep it in place, but not enough to prevent changing the angle of the XCS350 in the following steps.
11. The vertical angle of the XCS350 may be changed ± 5.5 degrees from perpendicular, allowing the sound to be directed upwards or downwards to accommodate the seating arrangement in the room. Refer to figure 11. This can be accomplished by temporarily loosening the three screws and moving the Stabilizer Bar up or down. When the desired angle is achieved, tighten the three screws.



Figure 11

12. Rotate the XCS350 Loudspeaker over with the front facing up, being careful not to damage the Loudspeaker Drivers. Refer to figure 12.

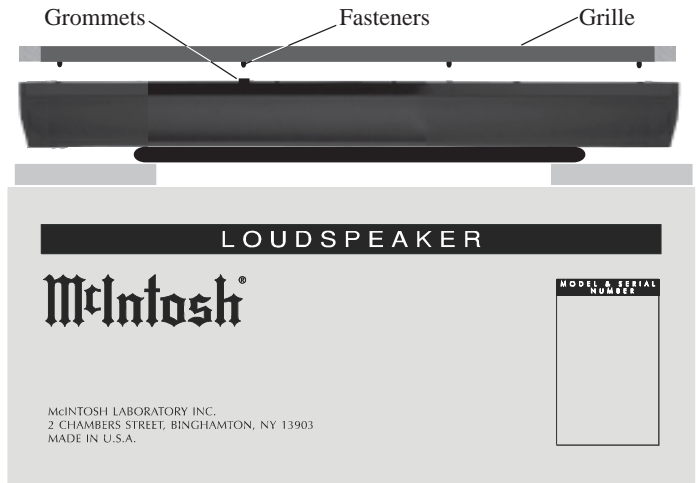

Figure 12

13. Locate the Loudspeaker Grille and align the Grille fasteners to the Loudspeaker Grommets (four on each side). Carefully push down to secure the Grille to the Loudspeaker.
14. Proceed to "Locating the Loudspeaker System" on page 18.

How to Mount the XLS320 Loudspeaker On the Wall

The supplied On Wall Mounting Brackets allow for two different mounting positions of the XLS320 Loudspeaker relative to the wall. The first position is flush mount, with the Loudspeaker close to and parallel with the wall. The second position is angle mount, which places the Loudspeaker further away from the wall and allows for horizontal rotation of ± 30 Degrees. Refer to figure 13.

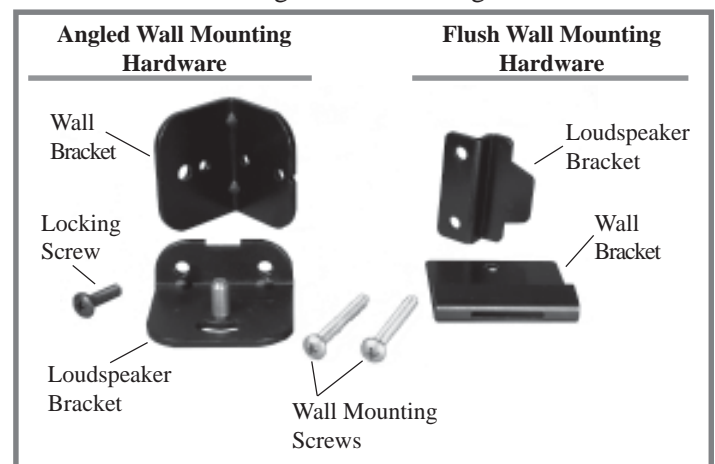

Figure 13

1. Using the supplied Allen Wrench, remove two screws from the rear of the XLS320 Loudspeaker System located below the recessed connection plate. Refer to figure 14 on the next page.

Installation, con't

- Attach either the flush mount or angle mount bracket to the rear of the Loudspeaker using the two screws (just removed in the previous step), being sure to orient the bracket as illustrated in figures 15 and 16.
- Determine the Loudspeaker Mounting Location on the wall, making sure the Mounting Bracket will be anchored to a stud located inside the wall.

Note: Use

extreme caution to avoid any existing electrical wiring, plumbing, etc., located inside the wall.



Figure 15

- Refer to figures 17 and 18 to install the appropriate Wall Bracket on the wall (orient the bracket as illustrated) using the supplied Mounting Screws. If the Flush Mount Bracket is used, attach the

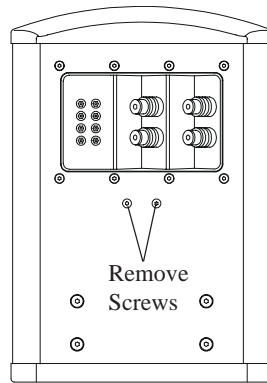

Figure 14

two cone shaped rubber bumpers to the rear of the Loudspeaker, near the bottom.

Note: If the wall covering material and/or thickness is different from the illustration, the two supplied Mounting Screws need to be replaced with screws of the appropriate type and length.

- Orient the Loudspeaker with the rounded end at the Top, carefully line up the Loudspeaker Bracket with the Wall Bracket and lower the Loudspeaker. If the angle mount is used, install the Locking Screw to secure the Loudspeaker at the desired angle.
- Align the Grille fasteners to the Loudspeaker Grommets (two on each side). Carefully push down to secure the Grille to the Loudspeaker.

How to Mount the XLS340 Loudspeaker On the Wall

The supplied On Wall Mounting Brackets allow for two different mounting positions of the XLS340 Loudspeaker relative to the wall. The first position is flush mount, with the Loudspeaker close to and parallel with the wall. The second position is angle mount, which places the Loudspeaker further away from the wall and allows for horizontal rotation of ± 30 Degrees. Refer to figure 19.

- Using the supplied Allen Wrench, remove four screws

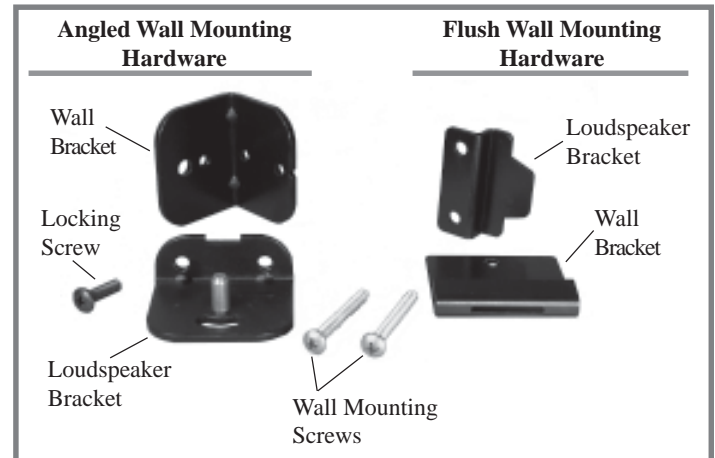

Figure 19

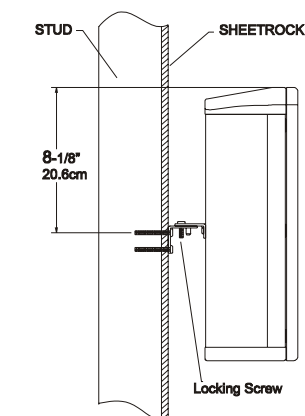

Figure 17

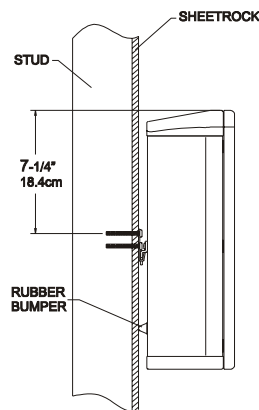
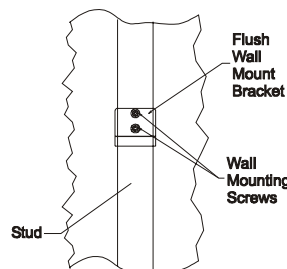
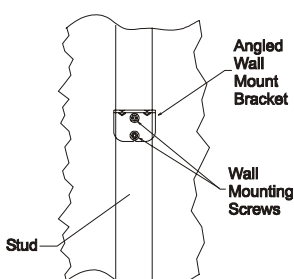

Figure 18



from the rear of the XLS340 Loudspeaker System. Refer to figure 20.

- Attach either the flush mount or angle mount brackets to the rear of the Loudspeaker using the four screws (just removed in the previous step), being sure to orient the bracket as illustrated in figures 21 and 22.
- Determine the Loudspeaker Mounting Location on the wall, making sure the Mounting Brackets will be anchored to a stud located inside the wall.

Note: Use extreme caution to avoid any existing electrical wiring, plumbing, etc., located inside the wall.

- Refer to figures 23 and 24 to install the appropriate Wall Brackets on the wall (orient the bracket as illustrated) using the supplied Mounting Screws. If the Flush Mount Brackets are used, optionally attach the two cone shaped rubber bumpers to the rear of the Loudspeaker, near the bottom.

Note: If the wall covering material and/or thickness is different from the illustration, the two supplied Mounting Screws need to be replaced with screws of the appropriate type and length.

- Orient the Loudspeaker with the rounded end at the Top, carefully line up the Loudspeaker Brackets with the Wall Brackets and lower the Loudspeaker. If the angle mount is used, install the Locking Screw for the top Bracket to secure the Loudspeaker at the desired angle.

- Align the Grille fasteners to the Loudspeaker Grommets (three on each side).

Carefully push down to secure the Grille to the Loudspeaker.

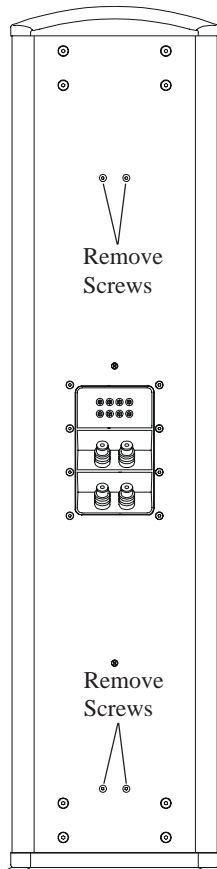

Figure 20

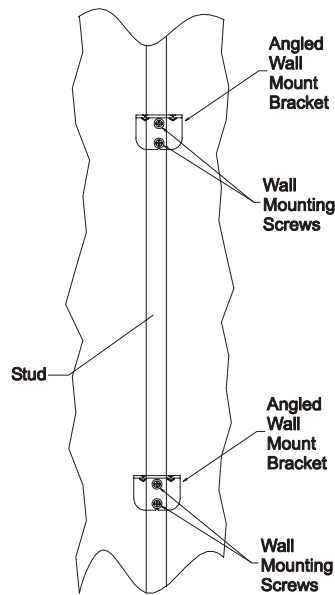
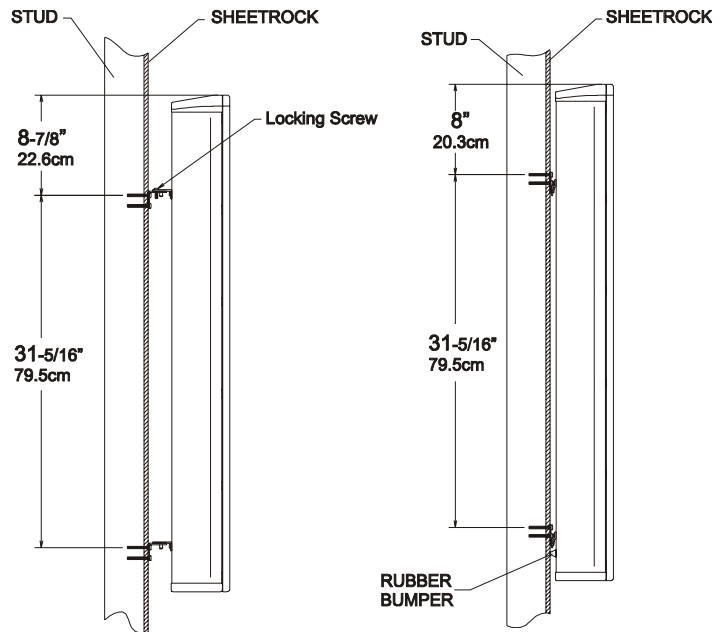

Figure 23

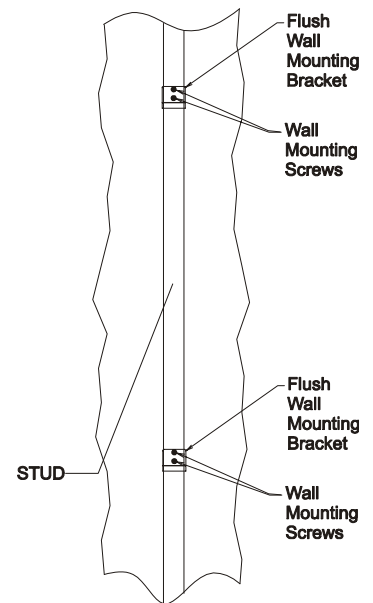

Figure 24



Figure 21



Figure 22

Installation, con't

How to Mount the XCS350 Loudspeaker On the Wall

The supplied On Wall Mounting Brackets allow for four different mounting positions of the XCS350 Loudspeaker relative to the wall, both vertical and horizontal. Two positions are flush mount, with the Loudspeaker close to and parallel with the wall. The other positions are angle mount, which places the Loudspeaker further away from the wall and allows for rotation of ± 30 Degrees. Refer to figure 25.

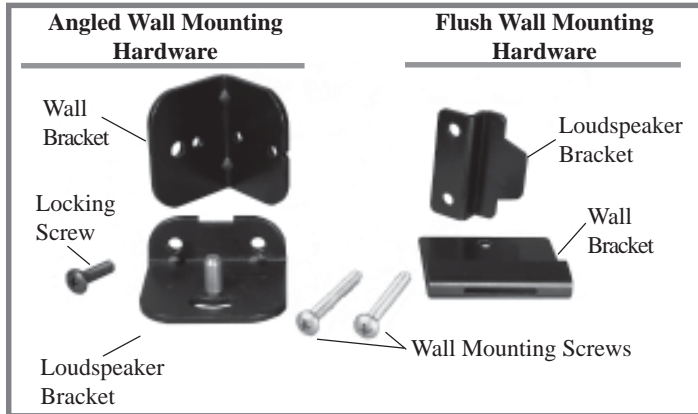

Figure 25

- Using the supplied Allen Wrench, remove the three screws securing the Stabilizer Bar to the back of the XCS350. Refer to figure 26. Replace the just removed center screw with a supplied one of the same type, but shorter length. Refer to figure 28.

Note: Retain the three removed screws and Stabilizer Bar for possible future use.

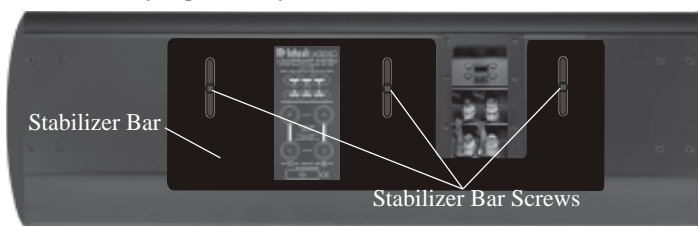

Figure 26

- Attach either the flush mount or angle mount brackets to the rear of the Loudspeaker using the supplied screws. Refer to figures 27, 28 and 29 for the screw location. Also, be sure to orient the bracket as illustrated in figure 30.

XCS350 Screw Removal for Mounting		
Mounting Type	Screws - A	Screws - B
Vertical Flush Mount	----	Remove
Vertical Angle Mount	----	Remove
Horizontal Flush Mount	Remove	----
Horizontal Angle Mount	----	Remove

Figure 27

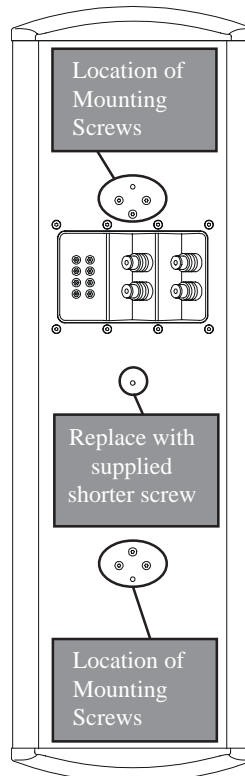

Figure 28

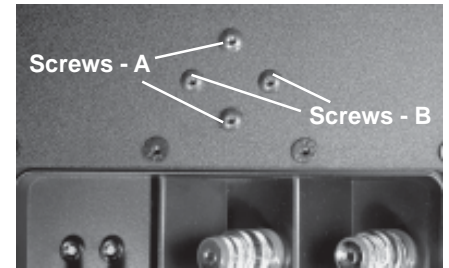

Figure 29

- Determine the Loudspeaker Mounting Location on the wall, making sure the Mounting Bracket will be anchored to a stud located inside the wall.

Note: Use extreme caution to avoid any existing electrical wiring, plumbing, etc., located inside the wall.

- Refer to figures 31 thru 34 to install the appropriate Wall Bracket on the wall (orient the bracket as illustrated) using the supplied Mounting Screws. If the Flush Mount Bracket is used, attach the two cone shaped rubber

bumpers to the rear of the Loudspeaker, near the bottom.

Note: If the wall covering material and/or thickness is different from the illustration, the two supplied Mounting Screws need to be replaced with screws of the appropriate type and length.

- Orient the Loudspeaker to line up with the Wall Brackets and attach them together. If the angle mount is used, install the Locking Screw to secure the Loudspeaker at the desired angle.

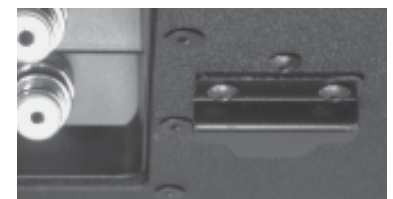
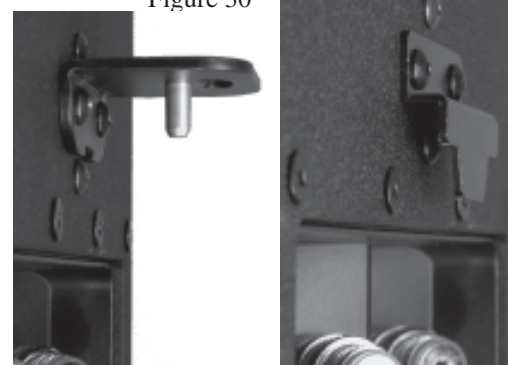

Figure 30



6. Align the Grille fasteners to the Loudspeaker Grommets (four on each side). Carefully push down to secure the Grille to the Loudspeaker.

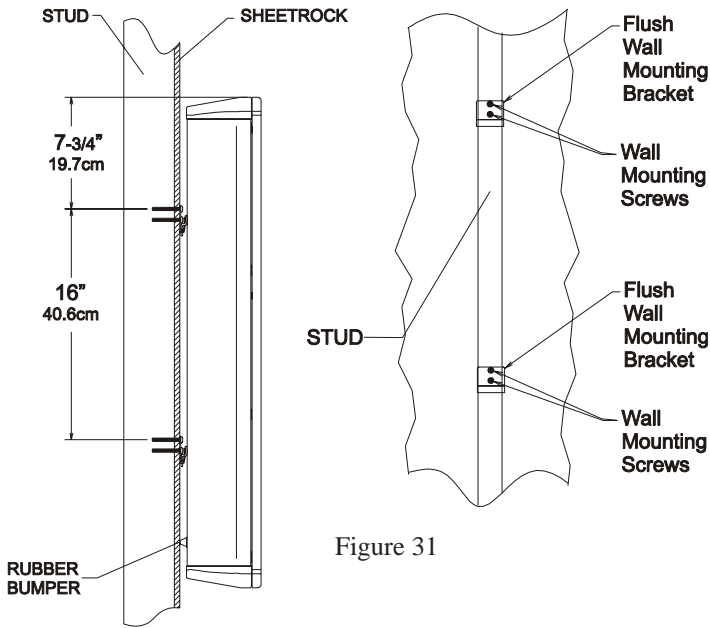

Figure 31

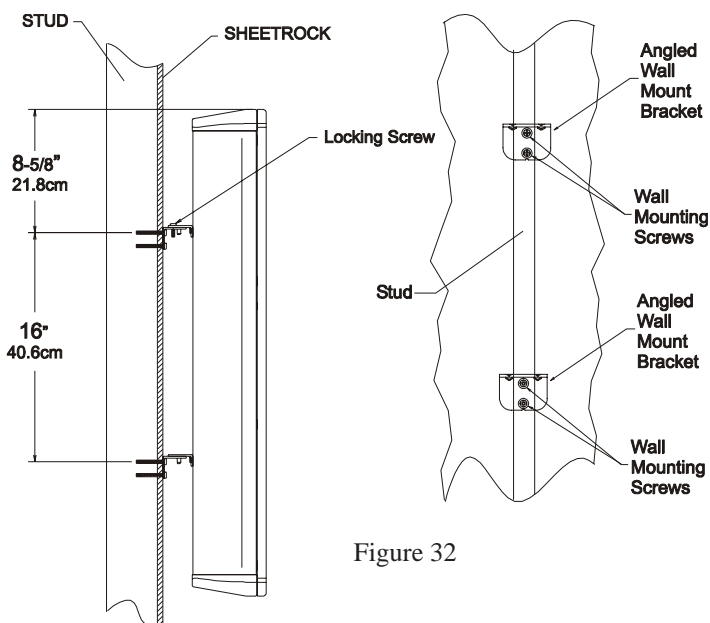

Figure 32

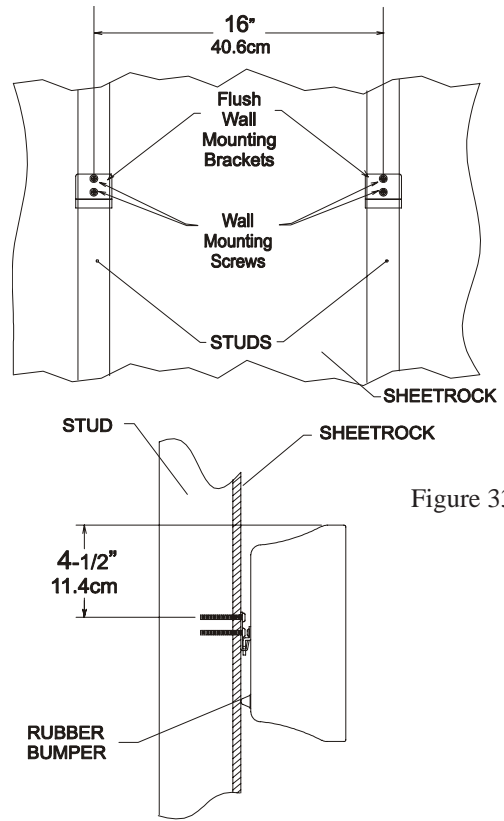

Figure 33

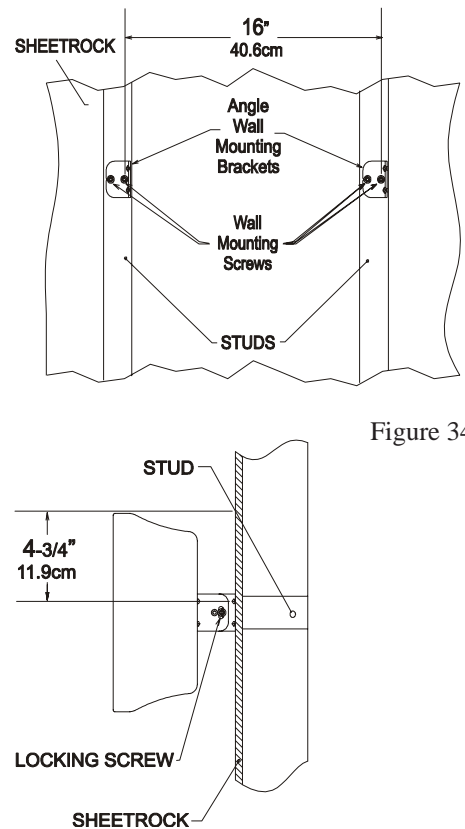

Figure 34

Installation, con't

Locating the Loudspeaker System

Loudspeaker placement in a room can greatly affect performance. The XLS320, XLS340, XLS360 and XCS350 are designed for use as a Left and Right Loudspeaker in a Music System, or as a Front and Surround Loudspeakers in a Home Theater System.

The optimal method for selecting speaker locations includes the use of a real time spectrum analyzer operated by the Professionals at your McIntosh Dealer. An uncompromising installation would take into consideration the floor, wall and ceiling coverings, the type and placement of furniture and can even include the architectural design of the room and its construction materials.

Locating Loudspeakers for use in Home Theater

In a Home Theater application, the placement of Front Loudspeakers can be limited by such considerations as the size and location of the video monitor. The locating suggestions in the “for use in a Music System” section below can still be helpful. Side Surround Loudspeakers work best located to either side of and above the listening position, the same distance from the monitor. Back Surround Loudspeakers work best on the back wall. Refer to figure 35.

Locating Loudspeakers for use in a Music System

When used in a Music System, the distance between the loudspeakers should not exceed the distance between the listener and either loudspeaker for the best sound imaging. Refer to figure 36. The Loudspeaker System’s Tweeter Array should be inline with the listeners’ ears. Placement near a wall, corner, floor, ceiling or any intersecting surfaces will reinforce some bass frequencies. Which bass frequencies are boosted by placement in a particular location is dependent on the dimensions of the room. Test the various loudspeaker locations by playing music with continuous bass, setting up the speakers and listening to them from the main listening spot. Move the loudspeakers to an alternate location and repeat the listening, paying attention to how articulate the bass notes are. Experiment with various loudspeaker positions until the locations that sound best are found.

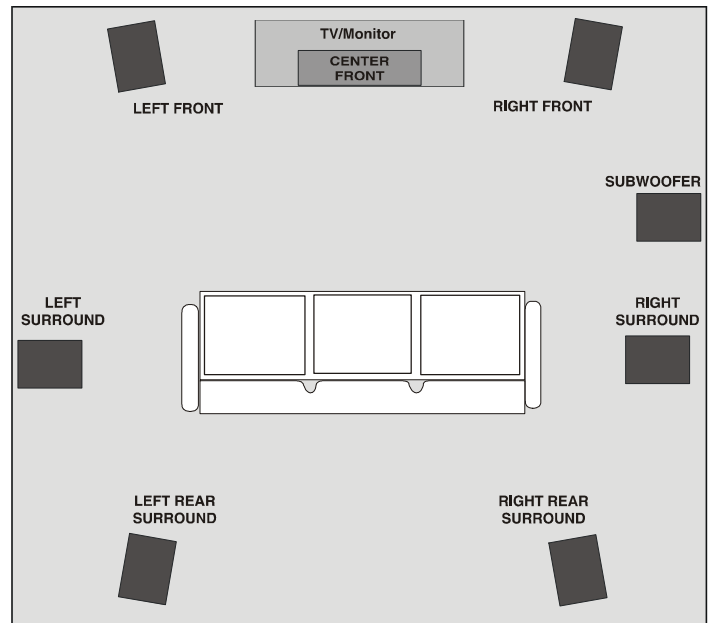

Figure 35

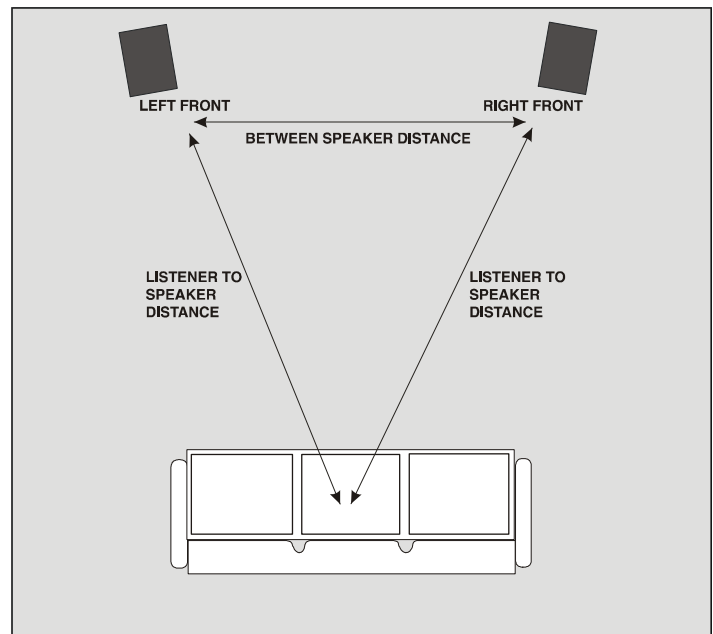

Figure 36

Tweeter Array Optimization

The XLS320, XLS340, XLS360 and XCS350 Loudspeaker Systems incorporate a special feature in the Crossover Network for optimization of the sound coming from the five tweeter array, refer to figure 37. The three different settings in the crossover network have to do with the physical location of the Loudspeaker in the Home Theater and/or Music System.



Figure 37

On the rear panel of the Loudspeaker System there is a recessed connection plate with binding posts for connection of hookup cables. Adjacent to the binding posts on the same recessed connection plate, are two rows of jacks with two McIntosh Jumpers already inserted, refer to figure 38. The default position of the jumpers for the XLS320, XLS340, and XLS360 Loudspeaker Systems, is RIGHT, refer to figure 39. The XCS350's default position of the jumpers is CENTER, refer to figure 40.



Figure 38



Figure 39



Figure 40



Figure 41

For the best sound performance, it is important to make sure the jumpers are set according to the Loudspeaker System location in the room. Refer to the chart below for the correct Jumper positions; if necessary, remove the two jumpers and reinsert them for the Loudspeaker location.

XLS320/340/360 and XCS350 Crossover Jumper Settings			
Loudspeaker Location	Left	Center	Right
Left Front	Jumpers	----	----
Center Front	----	Jumpers	----
Right Front	----	----	Jumpers
Left Surround	Jumpers	----	----
Right Surround	----	----	Jumpers
Left Back Surround	----	----	Jumpers
Right Back Surround	Jumpers	----	----



Connection for use with a Low Power Amplifier (default setting)

Preparing Hookup Cables

The McIntosh Loudspeaker Systems utilize binding posts for speaker wire connections. Prepare the Loudspeaker Hookup Cables that attach to the Power Amplifier Output Terminals:

Bare wire cable ends:

Carefully remove sufficient insulation from the cable ends, refer to figures 43, 44 and 45. If the cable is stranded, carefully twist the strands together as tightly as possible.

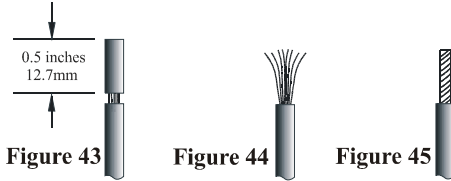

Note: If desired, the twisted ends can be tinned with solder to keep the strands together and/or attach a spade lug.

Spade lug or prepared wire connection:

Insert the spade lug connector or prepared section of the cable end into the terminal side access hole, and tighten the terminal cap until the cable is firmly clamped into the terminal so the wires cannot slip out. Refer to figures 46, 47 and 48.

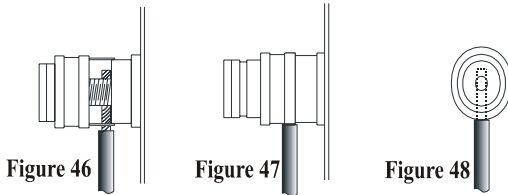

Connections using a single Amplifier

1. Connect a Loudspeaker cable from the COMMon (Negative) Binding Post of the appropriate Amplifier Channel to the Loudspeaker LOW POWER NEGATIVE (-) Binding Post.
2. Connect a Loudspeaker cable from the 8Ω (OHM) or Positive (+) Binding Post of the same Amplifier Channel to the Loudspeaker LOW POWER POSITIVE (+) Binding Post.

Note: The HIGH POWER and LOW POWER POSITIVE (+) Binding Posts must have a jumper installed between them.

3. Tighten all of the Loudspeaker and Amplifier Binding Posts.

Note: The Low Frequency Response of a XLS320 Loudspeaker may be extended when it is connected to a lower power amplifier. The Low Frequency Response of a XLS320 Loudspeaker may be extended even further with the addition of a Powered Subwoofer, like the McIntosh XLS112, to the Music/Home Theater System and connected as illustrated on page 18.

4. Connect the remaining Loudspeaker(s) and Amplifier Channel(s) in the same manner.

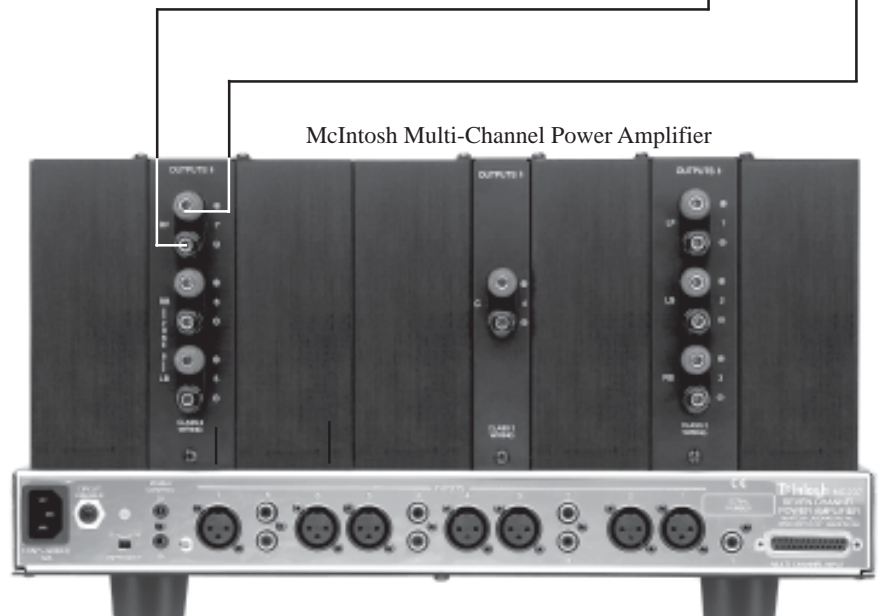
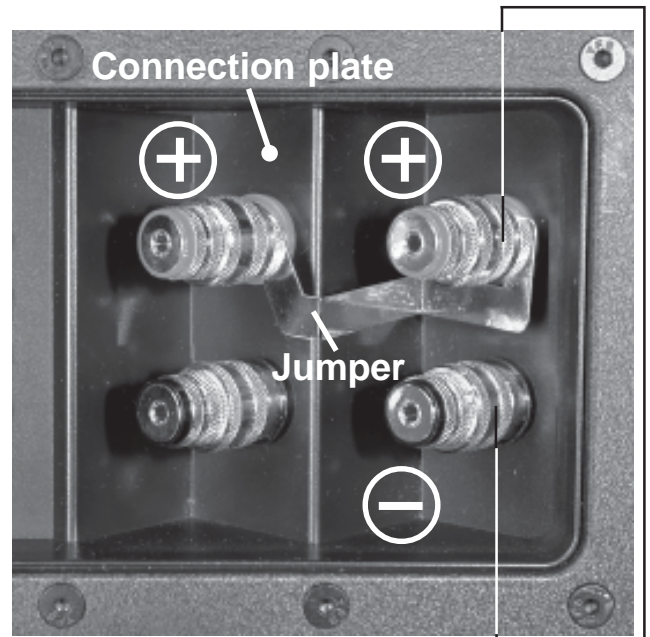

Connection for use with a High Power Amplifier (optional setting)

Preparing Hookup Cables

The McIntosh Loudspeaker Systems utilize binding posts for speaker wire connections. Prepare the Loudspeaker Hookup Cables that attach to the Power Amplifier Output Terminals:

Bare wire cable ends:

Carefully remove sufficient insulation from the cable ends, refer to figures 43, 44 and 45. If the cable is stranded, carefully twist the strands together as tightly as possible.

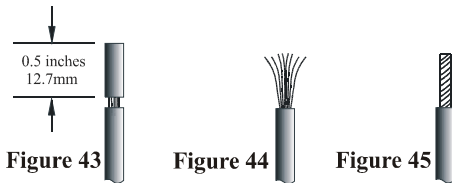

Note: If desired, the twisted ends can be tinned with solder to keep the strands together and/or attach a spade lug.

Spade lug or prepared wire connection:

Insert the spade lug connector or prepared section of the cable end into the terminal side access hole, and tighten the terminal cap until the cable is firmly clamped

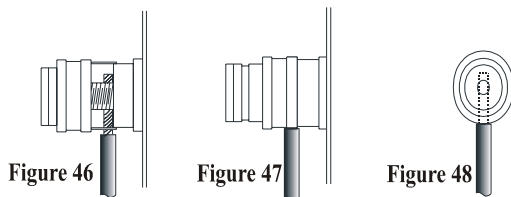

into the terminal so the wires cannot slip out. Refer to figures 46, 47 and 48.

Connections using a single Amplifier

1. Connect a Loudspeaker cable from the COMMon (Negative) Binding Post of the appropriate Amplifier Channel to the Loudspeaker HIGH POWER NEGATIVE (-) Binding Post.
2. Connect a Loudspeaker cable from the 8Ω (OHM) or Positive (+) Binding Post of the same Amplifier Channel to the Loudspeaker HIGH POWER POSITIVE (+) Binding Post.

Note: The HIGH POWER and LOW POWER NEGATIVE (-) Binding Posts must have a jumper installed between them.

3. Tighten all of the Loudspeaker and Amplifier Binding Posts.

Note: The Low Frequency Response of a XLS320 Loudspeaker may be extended with the addition of a Powered Subwoofer like the McIntosh XLS112 to the Music/Home Theater System.

4. Connect the remaining Loudspeaker(s) and Amplifier Channel(s) in the same manner.

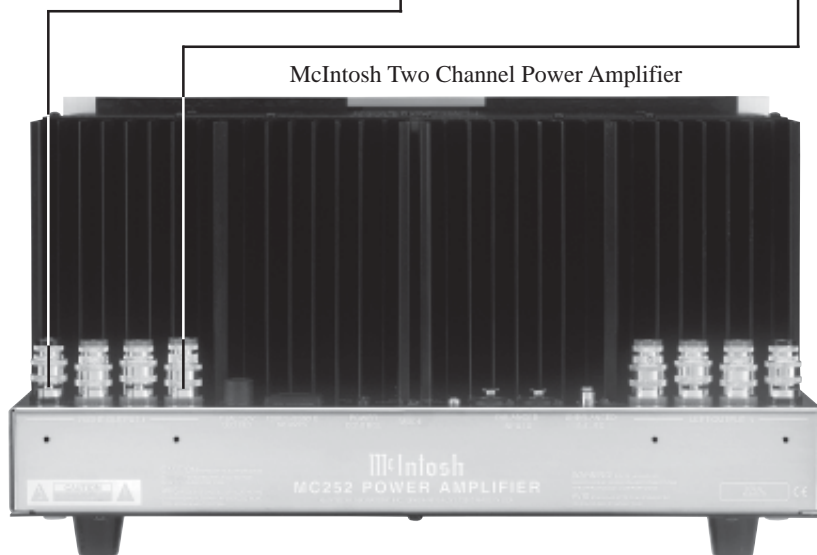
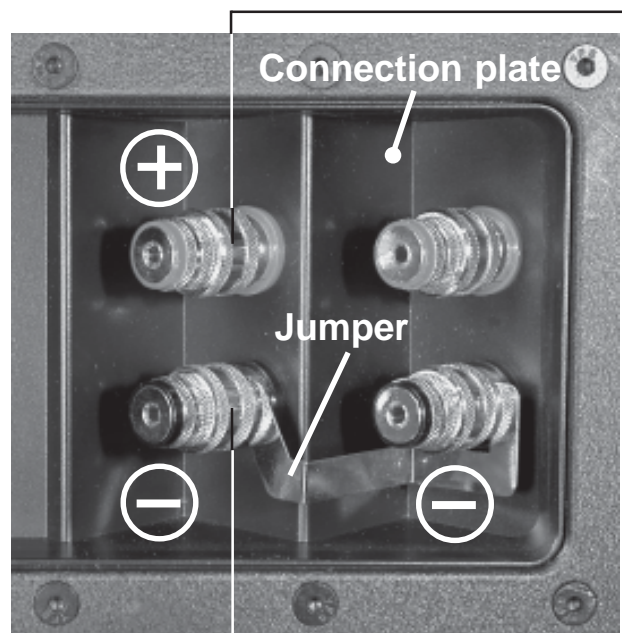



Connection with one Amplifier

Preparing Hookup Cables

The McIntosh Loudspeaker Systems utilize binding posts for speaker wire connections. Prepare the Loudspeaker Hookup Cables that attach to the Power Amplifier Output Terminals:

Bare wire cable ends:

Carefully remove sufficient insulation from the cable ends, refer to figures 43, 44 and 45. If the cable is stranded, carefully twist the strands together as tightly as possible.

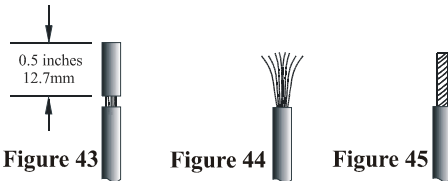

Note: If desired, the twisted ends can be tinned with solder to keep the strands together and/or attach a spade lug.

Spade lug or prepared wire connection:

Insert the spade lug connector or prepared section of the cable end into the terminal side access hole, and tighten the terminal cap until the cable is firmly clamped

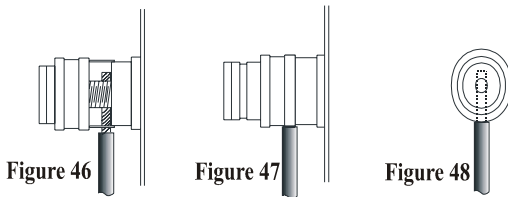

into the terminal so the wires cannot slip out. Refer to figures 46, 47 and 48.

Connections using a single Amplifier

1. Connect a Loudspeaker cable from the COMMon (Negative) Binding Post of the appropriate Amplifier Channel to the Loudspeaker NEGATIVE (-) Binding Post.
2. Connect a Loudspeaker cable from the 8Ω (OHM) or Positive (+) Binding Post of the same Amplifier Channel to the Loudspeaker POSITIVE (+) Binding Post.

Note: The WOOFER and MID/TWT NEGATIVE (-) Binding Posts must have a jumper installed between them. Likewise, the WOOFER and MID/TWT POSITIVE (+) Binding Posts must also have a jumper installed between them.

3. Tighten all of the Loudspeaker and Amplifier Binding Posts.
4. Connect the remaining Loudspeaker(s) and Amplifier Channel(s) in the same manner.

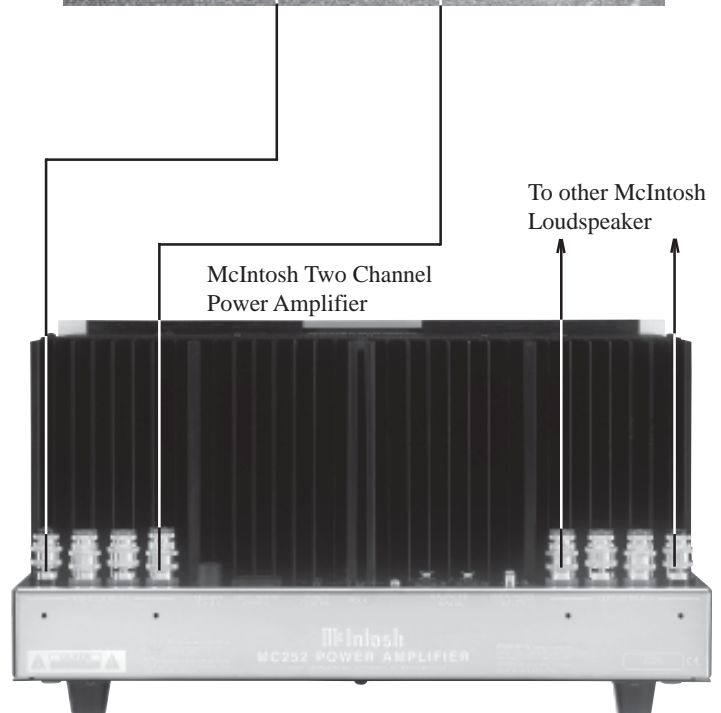
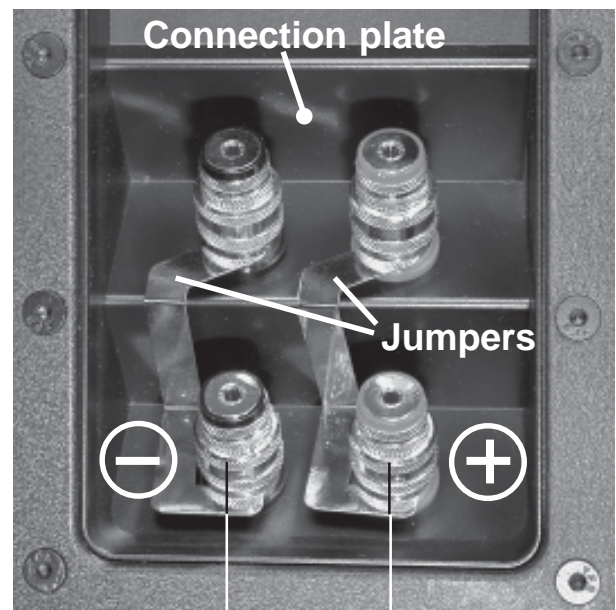

Connection with two Amplifiers

Preparing Hookup Cables

The McIntosh Loudspeaker Systems utilize binding posts for speaker wire connections. Prepare the Loudspeaker Hookup Cables that attach to the Power Amplifier Output Terminals:

Bare wire cable ends:

Carefully remove sufficient insulation from the cable ends, refer to figures 43, 44 and 45. If the cable is stranded, carefully twist the strands together as tightly as possible.

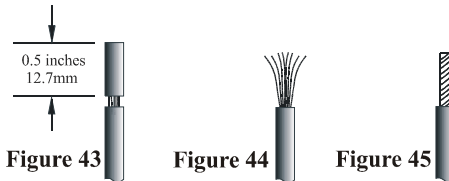

Note: If desired, the twisted ends can be tinned with solder to keep the strands together and/or attach a spade lug.

Spade lug or prepared wire connection:

Insert the spade lug connector or prepared section of the cable end into the terminal side access hole, and tighten the terminal cap until the cable is firmly clamped into the terminal so the wires cannot slip out. Refer to figures 46, 47 and 48.

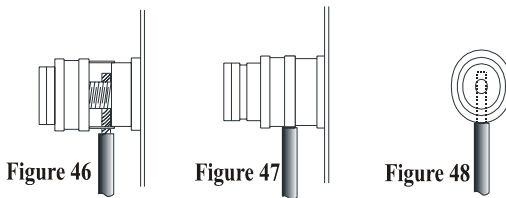

NEGATIVE (-) Binding Post.

3. Connect a Loudspeaker cable from the 8Ω (OHM) or Positive (+) Binding Post of the same Channel of Amplifier Number One to the Loudspeaker WOOFER POSITIVE (+) Binding Post.
4. Connect a Loudspeaker cable from the COMMon (Negative) Binding Post of the appropriate Channel of Amplifier Number Two to the Loudspeaker MID/TWT NEGATIVE (-) Binding Post.
5. Connect a Loudspeaker cable from the 8Ω (OHM) or Positive (+) Binding Post of the same Channel of Amplifier Number Two to the Loudspeaker MID/TWT POSITIVE (+) Binding Post.
6. Tighten all of the Loudspeaker and Amplifier Binding Posts.
7. Connect the remaining Loudspeaker(s) and Amplifier Channel(s) in the same manner.

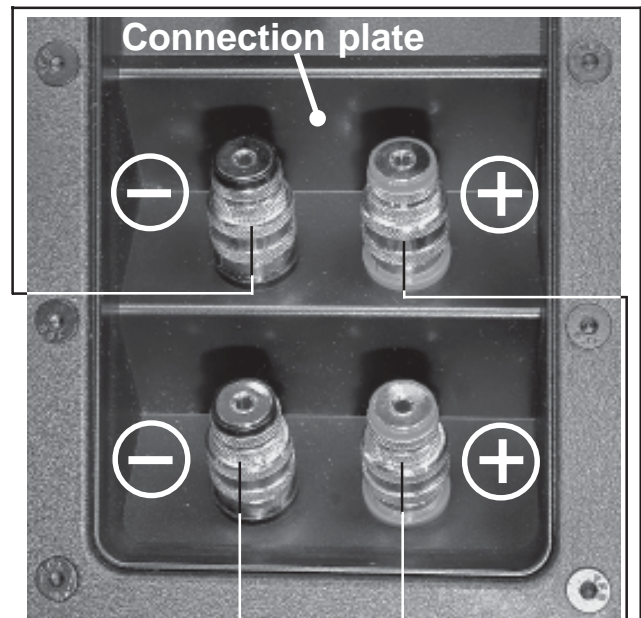

Connections using two Amplifiers

1. Remove both Jumpers between WOOFER and MID/TWT Binding Posts.
2. Connect a Loudspeaker cable from the COMMon (Negative) Binding Post of the appropriate Channel of Amplifier Number One to the Loudspeaker WOOFER

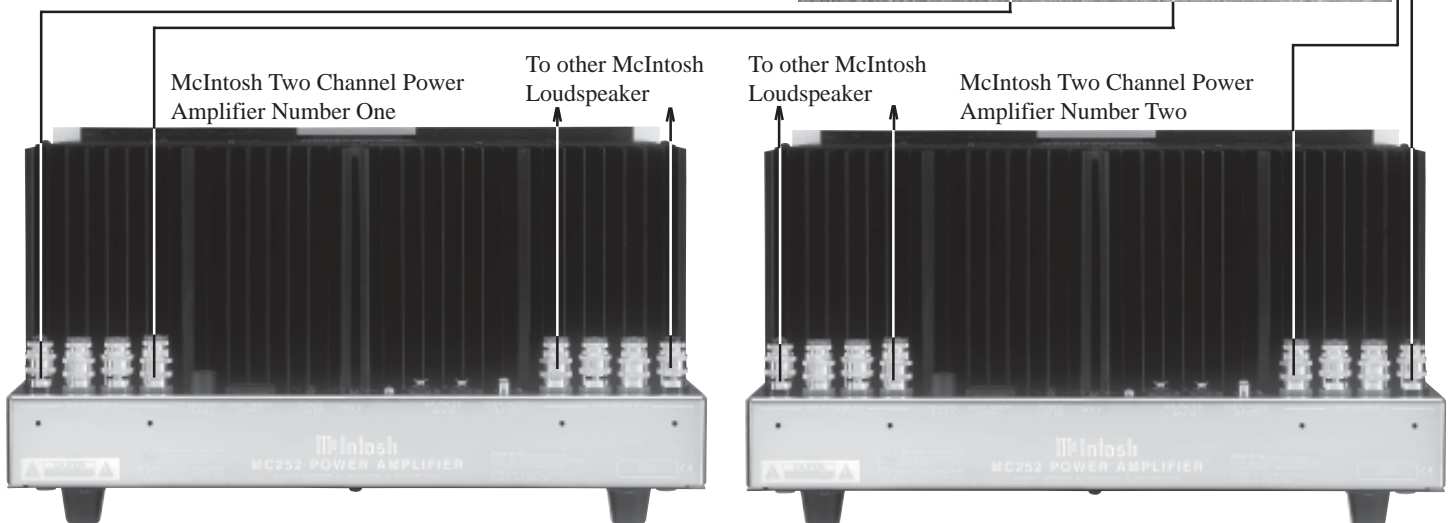



XLS320 Specifications

Driver Complement

One 6-1/2 inch LD/HP Woofers/Midrange
Five 1 inch Dome Tweeters (in a Bessel Function Array)

Impedance

8 ohms Nominal

Frequency Response

50Hz - 34kHz -6dB (Typical Room)
80Hz - 34kHz \pm 2dB (Anechoic Response)

High Pass Filter (High Power Connection)

12dB per octave roll off below 80Hz

Sensitivity

85dB (2.8V/1m)

Crossover Frequency

1.5kHz

Power Handling

250 Watts Maximum

Power Handling (High Power Connection)

400 Watts Maximum

Overall Dimensions

15-5/16 inches (38.9cm) Height
10-5/8 inches (27.0cm) Width
5-1/4 inches (13.3cm) Depth

Enclosure Finish

The outside of the enclosure is finished with a textured black powder coated finish; the front, top and bottom of the enclosure is covered with a thermal vacuum formed durable surface in a textured black finish.

Grille Finish

Black knit fabric with wood trim strips finished in Champagne Gold

Optional Wood Trim Finishes

Natural Cherry, Red Cherry or Black Ash
(Check with your McIntosh Dealer for Additional Details)

Weight (each)

24 pounds (10.9kg) net, 27 pounds (12.2kg) in shipping carton

XLS340 Specifications

Driver Complement

Two 8 inch LD/HP Woofers
One 6-1/2 inch LD/HP Midrange
Five 1 inch Dome Tweeters (in a Bessel Function Array)

Impedance

8 ohms Nominal

Frequency Response

38Hz - 34kHz -6dB (Typical Room)
65Hz - 34kHz \pm 2dB (Anechoic Response)

Sensitivity

85dB (2.8V/1m)

Crossover Frequencies

1.5kHz
250Hz

Power Handling

400 Watts Maximum

Overall Dimensions (including Floor Standing Base)

44-1/16 inches (111.9cm) Height
14-3/4 inches (37.5cm) Width
12 inches (30.5cm) Depth

Enclosure Finish

The outside of the enclosure is finished with a textured black powder coated finish; the front, top and bottom of the enclosure is covered with a thermal vacuum formed durable surface in a textured black finish. The base is also covered with a thermal vacuum formed durable surface in a textured black finish

Grille Finish

Black knit fabric with wood trim strips finished in Champagne Gold

Optional Wood Trim Finishes

Natural Cherry, Red Cherry or Black Ash
(Check with your McIntosh Dealer for Additional Details)

Weight (each)

69 pounds (31.3kg) net, 76 pounds (34.5kg) in shipping carton

XLS360 Specifications

Driver Complement

Two 10 inch LD/HP Woofers
One 6-1/2 inch LD/HP Midrange
Five 1 inch Dome Tweeters (in a Bessel Function Array)

Impedance

8 ohms Nominal

Frequency Response

34Hz - 34kHz -6dB (Typical Room)
55Hz - 34kHz \pm 2dB (Anechoic Response)

Sensitivity

85dB (2.8V/1m)

Crossover Frequencies

1.5kHz
250Hz

Power Handling

600 Watts Maximum

Overall Dimensions (including Floor Standing Base)

51-3/8 inches (130.5cm) Height
17-3/4 inches (45.1cm) Width
13 inches (33.0cm) Depth

Enclosure Finish

The outside of the enclosure is finished with a textured black powder coated finish; the front, top and bottom of the enclosure is covered with a thermal vacuum formed durable surface in a textured black finish. The base is also covered with a thermal vacuum formed durable surface in a textured black finish

Grille Finish

Black knit fabric with wood trim strips finished in Champagne Gold

Optional Wood Trim Finishes

Natural Cherry, Red Cherry or Black Ash
(Check with your McIntosh Dealer for Additional Details)

Weight (each)

107 pounds (48.5kg) net, 120 pounds (54.4kg) in shipping carton

XCS350 Specifications

Driver Complement

Two 8 inch LD/HP Woofers
One 6-1/2 inch LD/HP Midrange
Five 1 inch Dome Tweeters (in a Bessel Function Array)

Impedance

8 ohms Nominal

Frequency Response

45Hz - 34kHz -6dB (Typical Room)
80Hz - 34kHz \pm 2dB (Anechoic Response)

Sensitivity

85dB (2.8V/1m)

Crossover Frequencies

1.5kHz
250Hz

Power Handling

400 Watts Maximum

Overall Dimensions (including Stabilizer Bar)

10-5/8 inches (27cm) Height
34-1/16 inches (86.5cm) Width
6 inches (15.3cm) Depth

Enclosure Finish

The outside of the enclosure is finished with a textured black powder coated finish; the front and side ends of the enclosure are covered with a thermal vacuum formed durable surface in a textured black finish.

Grille Finish

Black knit fabric with wood trim strips finished in Champagne Gold

Optional Wood Trim Finishes

Natural Cherry, Red Cherry or Black Ash
(Check with your McIntosh Dealer for Additional Details)

Weight (each)

49 pounds (22.2kg) net, 55 pounds (24.9kg) in shipping carton



Packing Instructions

In the event it is necessary to repack the equipment for shipment, the equipment must be packed exactly as shown below. The XLS360 shipping carton uses banding straps to make sure the box is held together securely.

Note: The Floor Stand must be removed from the XLS340/ XLS360 Loudspeaker and packed in its own shipping carton.

Use the original shipping carton and parts only if they are in good serviceable condition. If a shipping carton or any of the interior part(s) are needed, please call or write Customer Service Department of McIntosh Laboratory. Please see the Parts List for the correct part numbers.

XLS320 Shipping Carton and Parts List

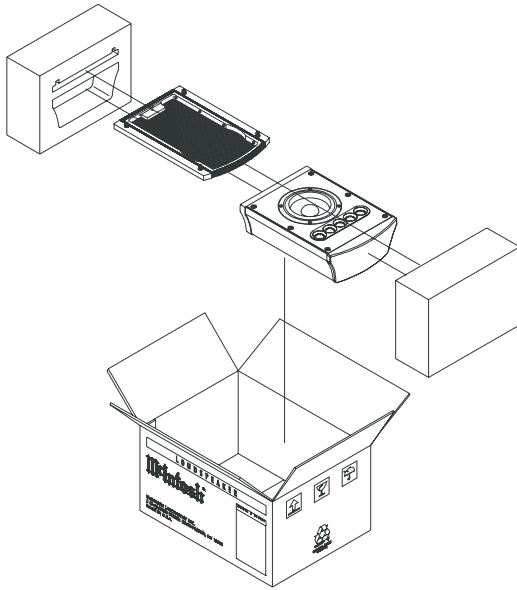

<u>Quantity</u>	<u>Part Number</u>	<u>Description</u>
1	034293	Shipping carton
2	034291	Foam end caps

XLS340 Shipping Cartons and Parts List

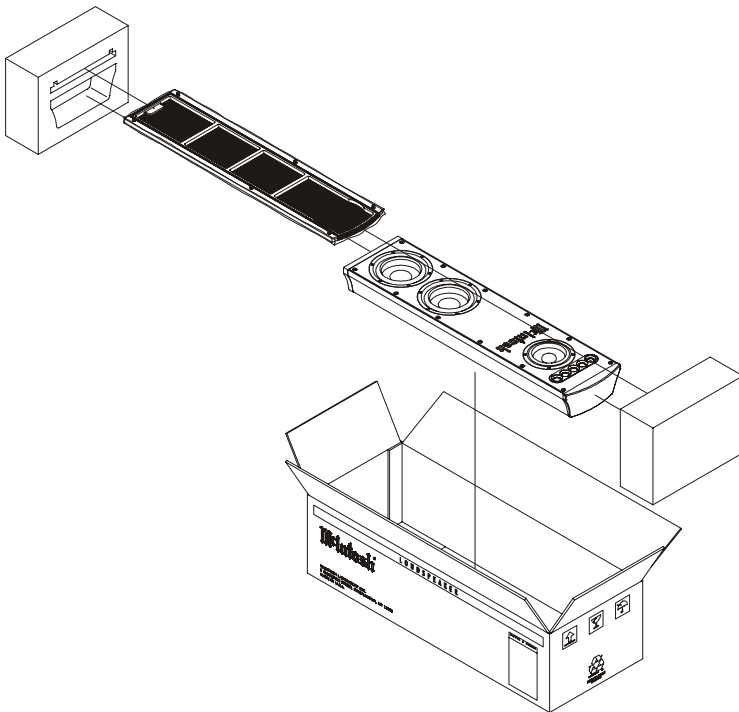

<u>Quantity</u>	<u>Part Number</u>	<u>Description</u>
1	034292	Shipping carton
2	034291	Foam end caps
1	034207	Floor stand shipping carton
1	033300	Microfoam to wrap up the floor stand
1	033085	Air Cap bottom pad

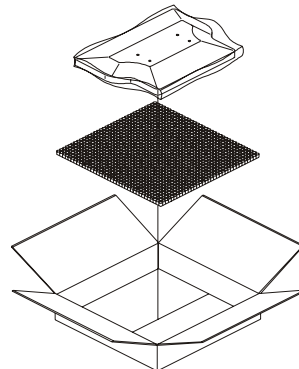

XLS360 Shipping Cartons and Parts List

	<u>Quantity</u>	<u>Part Number</u>	<u>Description</u>
	1	034290	Shipping carton top
	1	034289	Shipping carton bottom
	2	034244	Foam end caps
	1	034245	Foam center cap
	1	034309	Floor stand shipping carton
	1	033300	Microfoam to wrap up the floor stand
	1	033085	Air Cap bottom pad

XCS350 Shipping Carton and Parts List

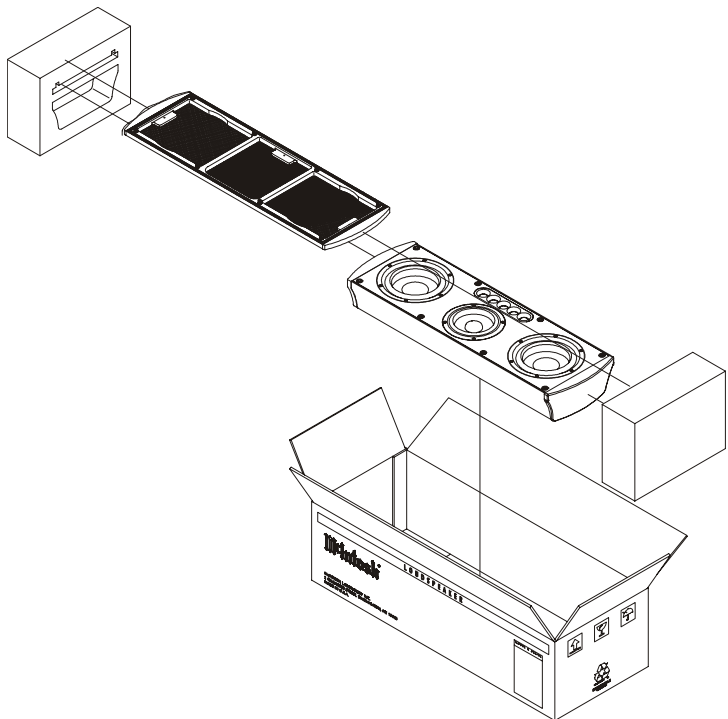



McIntosh Laboratory, Inc.
2 Chambers Street
Binghamton, NY 13903

The continuous improvement of its products is the policy of McIntosh Laboratory Incorporated who reserve the right to improve design without notice.

Printed in the U.S.A.

McIntosh Part No. 04094100