

# ADAMS INTERburner®

## Mark 10

### HIGH EFFICIENCY COMBUSTION EQUIPMENT



Patented Turbo-Reversed-Air System  
or TRA, the major breakthrough that accounts  
for INTERburner's fuel economy.

#### INTERburner Features:

- Quiet running. Dramatically lower noise level than other oil burners.
- Adjustable drawer assembly to simplify inventory. One cone and head assembly from .4 GPH through 2.5 GPH.
- Removable chassis for easy servicing. Leaves burner air tube in place.

- One-piece electrode assembly for easy adjustment.
- Eliminates pulsation.
- Minimizes stand-by losses without special mechanical parts.
- Mounts with blower up, down or at an angle with equal performance.
- Cool head ceramic protected cone.



INTERburner® Division • Adams Manufacturing Co., 9790 Midwest Ave., Cleveland, Ohio 44125  
(216) 587-6801

MAKERS OF CLEANAIRE® HUMIDAIRE® SUPER VENTER, SPARKLITE® SPEEDFLAME® AND SPEEDY®

# ADAMS INTERburner®

## INTERburner Turbo Reversed (TRA) Air Flow Pattern

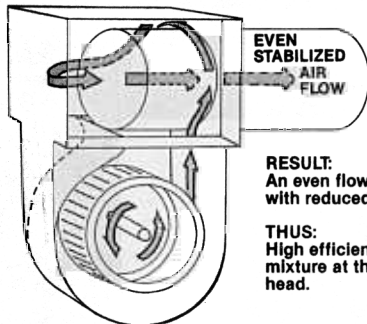

**RESULT:**  
An even flow of air  
with reduced velocity.

**THUS:**  
High efficiency fuel/air  
mixture at the combustion  
head.

## Conventional Oil Burner Air Flow Pattern

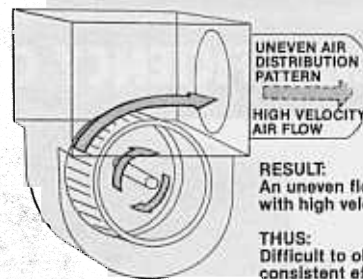

**RESULT:**  
An uneven flow of air  
with high velocity core.

**THUS:**  
Difficult to obtain a  
consistent efficient  
fuel/air mixture at  
the combustion head.

Patented Turbo-Reversed-Air System or TRA, the major breakthrough that accounts for INTERburner's fuel economy. Inside each INTERburner, TRA stabilizes dynamic pressure while maintaining high static pressure. It creates the most uniform airflow at the combustion head and gives

precise control for the most effective mixing of combustion air with the oil *on* the combustion head . . . accomplishing efficiency levels never before achieved. INTERburner's flame burns hotter and cleaner . . . requiring less fuel to heat your home.

## DIMENSIONS

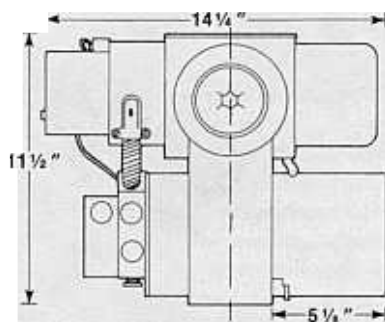
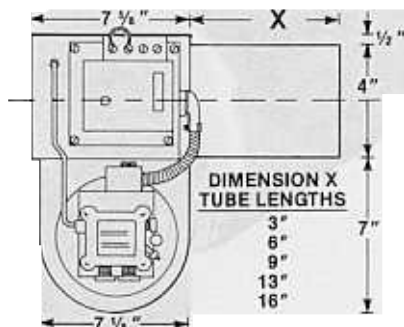

## SPECIFICATIONS

### CAPACITIES

0.40 to 2.50G/P/H, 56,000 to 350,000 B.T.U./Hr. Input.  
Other models available to 7 G/P/H.

### FUEL

No. 1 or No. 2 Heating Oil.

### POWER REQUIREMENTS

115 Volts, 60 Hertz, Single Phase.

### MOTOR

3450 R.P.M., 1/7 H.P. 115 V., NEMA "M" Flange.

### IGNITION TRANSFORMER

10,000 Volts.

### CONTROLS

24 Volt Primary Cad Cell Control. Intermittent or Interrupted Ignition.

### FUEL PUMP

3450 R.P.M., 100 P.S.I., Single or 2 Stage with or without Integral Solenoid Valve.

### MOUNTING

Universal Flange and Gasket. Burner Stand Kit — Burner can be mounted in inverted position.

### NOZZLE SIZE

Selection Chart on each burner cover.

**Distributed by:**



Accept only the best.  
Insist on INTERburner®

INTERburner® Division • Adams Manufacturing Co., 9790 Midwest Ave., Cleveland, Ohio 44125  
(216) 587-6801