

# *Grizzly* *Industrial, Inc.*®

## MODEL T23094 PNEUMATIC METAL SHEAR OWNER'S MANUAL



COPYRIGHT © APRIL, 2011 BY GRIZZLY INDUSTRIAL, INC.  
WARNING: NO PORTION OF THIS MANUAL MAY BE REPRODUCED IN ANY SHAPE  
OR FORM WITHOUT THE WRITTEN APPROVAL OF GRIZZLY INDUSTRIAL, INC.

#CR14035 PRINTED IN CHINA



## **WARNING!**

This manual provides critical safety instructions on the proper setup, operation, maintenance, and service of this machine/tool. Save this document, refer to it often, and use it to instruct other operators.

Failure to read, understand and follow the instructions in this manual may result in fire or serious personal injury—including amputation, electrocution, or death.

The owner of this machine/tool is solely responsible for its safe use. This responsibility includes but is not limited to proper installation in a safe environment, personnel training and usage authorization, proper inspection and maintenance, manual availability and comprehension, application of safety devices, cutting/sanding/grinding tool integrity, and the usage of personal protective equipment.

The manufacturer will not be held liable for injury or property damage from negligence, improper training, machine modifications or misuse.



## **WARNING!**

Some dust created by power sanding, sawing, grinding, drilling, and other construction activities contains chemicals known to the State of California to cause cancer, birth defects or other reproductive harm. Some examples of these chemicals are:

- Lead from lead-based paints.
- Crystalline silica from bricks, cement and other masonry products.
- Arsenic and chromium from chemically-treated lumber.

Your risk from these exposures varies, depending on how often you do this type of work. To reduce your exposure to these chemicals: Work in a well ventilated area, and work with approved safety equipment, such as those dust masks that are specially designed to filter out microscopic particles.

# Table of Contents

<b>SAFETY</b> .....	<b>2</b>
Safety Instructions for Pneumatic Tools .....	2
Additional Safety Instructions for Pneumatic Shears .....	3
<b>SECTION 1: INTRODUCTION</b> .....	<b>4</b>
Foreword .....	4
Specifications .....	4
Contact Info .....	4
Identification .....	5
<b>SECTION 2: SETUP</b> .....	<b>6</b>
Unpacking .....	6
Inventory .....	6
Assembly .....	6
<b>SECTION 3: OPERATIONS</b> .....	<b>7</b>
Operation Overview .....	7
<b>SECTION 4: ACCESSORIES</b> .....	<b>8</b>
<b>SECTION 5: MAINTENANCE</b> .....	<b>10</b>
<b>SECTION 6: SERVICE</b> .....	<b>11</b>
Troubleshooting .....	11
<b>SECTION 7: PARTS</b> .....	<b>13</b>
Main Parts Diagram .....	13
Main Parts List .....	13
<b>WARRANTY</b> .....	<b>14</b>

# SAFETY

## **WARNING**

### **For Your Own Safety Read Instruction Manual Before Operating This Equipment**

The purpose of safety symbols is to attract your attention to possible hazardous conditions. This manual uses a series of symbols and signal words which are intended to convey the level of importance of the safety messages. The progression of symbols is described below. Remember that safety messages by themselves do not eliminate danger and are not a substitute for proper accident prevention measures.

#### **DANGER**

Indicates an imminent hazardous situation which, if not avoided, **WILL** result in death or serious injury.

#### **WARNING**

Indicates a potentially hazardous situation which, if not avoided, **COULD** result in death or serious injury.

#### **CAUTION**

Indicates a potentially hazardous situation which, if not avoided, **MAY** result in minor or moderate injury. It may also be used to alert against unsafe practices.

#### **NOTICE**

This symbol is used to alert the user to useful information about proper operation of the equipment.

## **WARNING**

### **Safety Instructions for Pneumatic Tools**

**KEEP ALL SAFETY DEVICES IN PLACE** and in working order.

**REMOVE ADJUSTING KEYS AND WRENCHES.** Form habit of checking to see that keys and adjusting wrenches are removed from tool before operation.

**KEEP WORK AREA CLEAN.** Cluttered areas and benches invite accidents.

**KEEP CHILDREN AND VISITORS AWAY.** All children and visitors should be kept at a safe distance from work area.

**MAKE WORKSHOP CHILD PROOF.** Make sure to lock your shop and shut-**OFF** the power and air supply.

**DO NOT FORCE TOOL.** It will do the job better and safer at the rate for which it was designed.

**USE THE RIGHT TOOL.** Do not force tool or attachment to do a job for which it was not designed.

**DO NOT USE UNDER THE INFLUENCE OF DRUGS OR ALCOHOL, OR WHEN TIRED.**

**USE CORRECT AIR PRESSURE.**

Exceeding the maximum PSI rating of this tool may cause seal damage, unpredictable operation, or line burst.

## **WARNING**

**USE PROPER AIR HOSE** for the tool. Make sure your air hose is in good condition and is long enough to reach your work without stretching.

**SECURE WORK.** Use clamps or a vise to hold work when practical. It is safer than using your hand and frees both hands to operate tool.

**MAINTAIN TOOLS WITH CARE.** Keep tools lubricated and clean for best and safest performance. Follow instructions for lubricating and changing accessories.

**PREVENT ACCIDENTAL OPERATION.** Do not carry tool with hand on trigger and always disconnect from air when not in use.

**MAINTAIN TOOLS WITH CARE.** Keep tools lubricated and clean for best and safest performance. Follow instructions for lubricating and changing accessories.

**BE AWARE OF HOSE LOCATION.** Hoses can easily become a tripping hazard when laid across the floor in a disorganized fashion.

**WEAR APPROVED HEARING PROTECTION.** Air escaping from pneumatic tools can exceed safe exposure limits and may cause hearing damage with prolonged exposure.

**AIR LINE CONNECTION INSPECTION.** An air line that becomes disconnected from a tool can whip violently, causing severe injury. Verify that air line is properly connected and the fittings are tight and free of leaks. A leaking fitting can indicate the fitting is cracked and is about to fail.

**WEAR PROPER APPAREL.** Do not wear loose clothing, gloves, neckties, rings, bracelets, or other jewelry that may get caught in moving parts. Non-slip footwear is recommended. Wear a protective hair covering to contain long hair.

**ALWAYS USE SAFETY GLASSES.** Also use a face or dust mask if cutting operation is dusty. Everyday eyeglasses only have impact resistant lenses, they are NOT safety glasses.

## **WARNING**

### **Additional Safety Instructions for Pneumatic Shears**

**CHANGING BITS.** When servicing or removing metal from the jaws, disconnect the shear from air to prevent an accidental start-up injury.

**TOOL STABILITY.** To establish the best control possible when cutting, hold the handle and housing with two hands, and stabilize your hands and body against a fixed object. When free-hand cutting (using one hand) use a guide to slide the pneumatic shear along when making the cut to avoid severe injury.

## **CAUTION**

No list of safety guidelines can be complete. Every shop environment is different. Always consider safety first, as it applies to your individual working conditions. Use this and other tools with caution and respect. Failure to do so could result in serious personal injury, damage to equipment or poor work results.

# SECTION 1: INTRODUCTION

---

---

## Foreword

---

---

We are proud to offer this manual with your new T23094! We've made every effort to be exact with the instructions, specifications, drawings, and photographs of the T23094 we used when writing this manual. However, sometimes we still make an occasional mistake.

Also, owing to our policy of continuous improvement, your T23094 may not exactly match the manual. If you find this to be the case, and the difference between the manual and T23094 leaves you in doubt, check our website for the latest manual update or call technical support for help.

For your convenience, we post all available manuals and manual updates for free on our website at [www.grizzly.com](http://www.grizzly.com). Any updates to your model of tool will be reflected in these documents as soon as they are complete.

## Contact Info

---

---

We stand behind our products. If you have any service questions, parts requests or general questions about the product, please call or write us at the location listed below.

Grizzly Industrial, Inc.  
1203 Lycoming Mall Circle  
Muncy, PA 17756  
Phone: (570) 546-9663  
E-Mail: [techsupport@grizzly.com](mailto:techsupport@grizzly.com)

We want your feedback on this manual. If you can take the time, please email or write to us at the address below and tell us how we did:

Grizzly Industrial, Inc.  
C/O Technical Documentation Manager  
P.O. Box 2069  
Bellingham, WA 98227-2069  
Email: [manuals@grizzly.com](mailto:manuals@grizzly.com)

## Specifications

---

---

Jaw Strokes Per Minute.....	1,800
Average Air Flow.....	5 CFM
Swivel Head Adjustment.....	360°
Maximum Cutting Thickness (Plastics).....	12 Gauge
Maximum Cutting Thickness (Sheet Aluminum).....	14 Gauge
Maximum Cutting Thickness (Mild Sheet Steel).....	20 Gauge
Maximum Cutting Thickness (Stainless Steel).....	22 Gauge
Width of Cut.....	5.05mm
Operating Air Pressure.....	90 PSI
Maximum Air Pressure.....	100 PSI
Air Inlet Size.....	1/4" NPT
Minimum Air Hose Inside Diameter.....	3/8"
Net Weight.....	2.8 lbs
Shipping Weight.....	3 lbs

# Identification

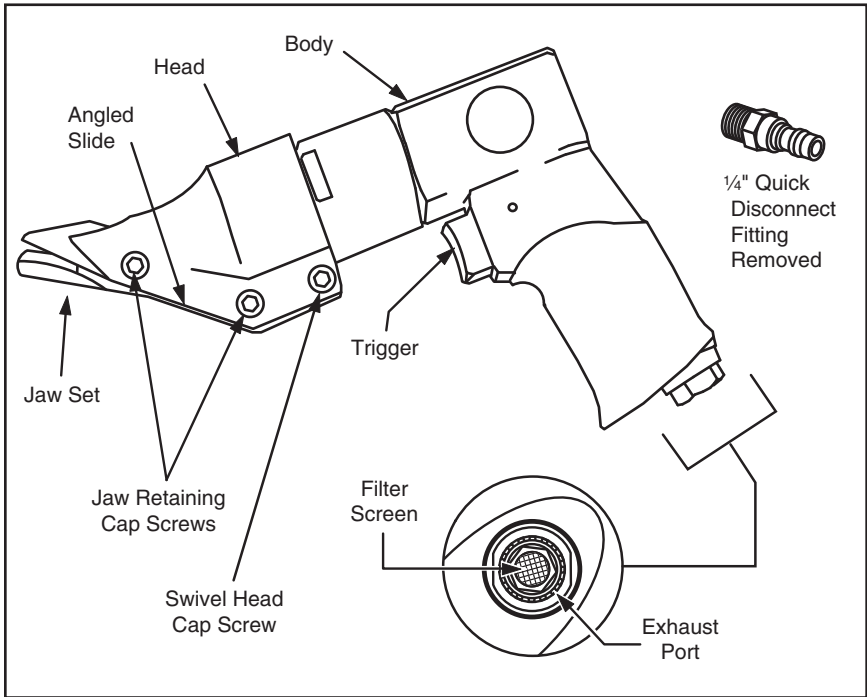

Figure 1. Components and controls.

**⚠ WARNING**

This tool presents serious injury hazards to untrained users. Read through this entire manual to become familiar with the controls and operations before using the tool!

# SECTION 2: SETUP

## Unpacking

Your tool was carefully packaged for safe transportation. Remove the packaging materials from around your tool and inspect it. If you discover the tool is damaged, please immediately call Customer Service at (570) 546-9663 for advice.

Save the containers and all packing materials for possible inspection by the carrier or its agent. Otherwise, filing a freight claim can be difficult. When you are completely satisfied with the condition of your shipment, inventory the contents.

If any non-proprietary parts are missing (e.g., a nut or a washer), we will gladly replace them; or for the sake of expediency, replacements can be obtained at your local hardware store.

## Inventory

### Model T23094 Inventory (Figure 2)

- A. Pneumatic Metal Shear ..... 1
- B. Quick Disconnect Air Fitting..... 1
- C. Bottle for Oil ..... 1
- D. Hex Wrench 4mm ..... 1

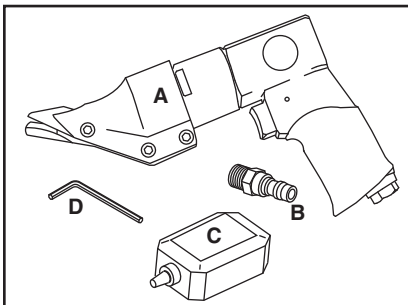

Figure 2. Inventory.

## Assembly

### To assemble the pneumatic shear:

1. Remove the plastic plug from the air inlet in the handle.
2. Apply pipe sealant on the threads of the quick disconnect fitting.
3. Thread the fitting into the pneumatic shear air inlet and tighten.
4. Press the trigger, and place a few drops of air tool oil into the air inlet, and release the trigger. The pneumatic shear is ready for use.

### Air supply setup tips:

- If the air hose is longer than 25-feet, increase the air pressure to 100 PSI to compensate for air flow restriction.
- For consistent air flow, use air hoses with an inside diameter of  $\frac{3}{8}$ " or larger.
- To eliminate air system moisture and maintain automatic lubrication, install a main or in-line filter water separator as far as possible from the air compressor, but before any automatic in-line oiler. See examples in Figure 3.

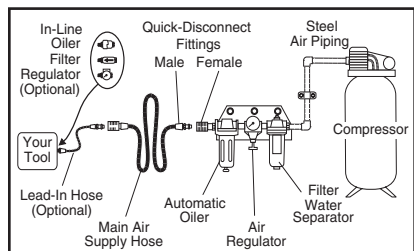
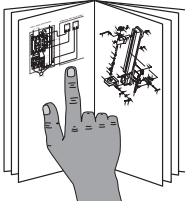

Figure 3. Typical air supply system.



# SECTION 3: OPERATIONS

## **⚠️ WARNING**



This tool presents serious injury hazards to untrained users. Read through this entire manual to become familiar with the controls and operations before using the tool!

## **⚠️ WARNING**



**EYE INJURY HAZARD!**  
Wear safety goggles with full eye protection from all sides when using this grinder.

## **⚠️ WARNING**



**LUNG/EAR INJURY HAZARD!**  
Wear protective equipment when using this tool.

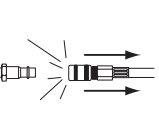

**ACCIDENTAL START HAZARD!**  
Disconnect before service or tool changes.

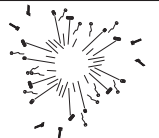

**AIR PRESSURE HAZARD!**  
Never exceed max PSI rating for tool.

## Operation Overview

To complete a typical cutting operation, the following is done:

1. Put on safety goggles and gloves.
2. Mark the cut line, secure the workpiece, and clamp a guide to the workpiece if needed.
3. Determine if the swivel head needs to be rotated for optimum tool control and cut line viewing.
  - If so, loosen the swivel head cap screw (see **Figure 1**, on **Page 5**), rotate the head to the required angle, and retighten the cap screw.
4. Apply a few drops of air tool oil on the jaws and in the air inlet fitting.
5. Connect the air supply hose to the pneumatic shear.
6. Engage the tip of the jaws against the edge of the sheet metal.
7. Pull the trigger, and in a controlled manner, push the shear into the workpiece to begin cutting. As the cut progresses, keep the angled slide (see **Figure 1**, on **Page 5**) flat against the surface of the sheet metal, so the jaws and sheet metal do not bind.
8. When finished, or if leaving the area, disconnect the shear from air, and store it away from children.

# SECTION 4: ACCESSORIES

## T23103—12" Slip Roll

This slip roll is just the ticket for live steamers, model makers and small jobbers. With its 12" ground and polished rolls it can handle mild steel up to 22 gauge and also has  $\frac{5}{32}$ ",  $\frac{15}{64}$ " and  $\frac{5}{16}$ " diameter grooves to handle rod and wire. A great little machine!

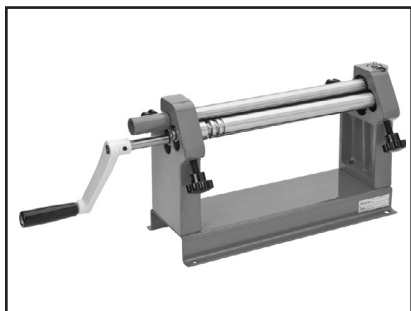

Figure 4. 12" slip roll.

## G7147—12" Hand Brake

This hand brake is perfect for the home hobbyist and those delicate forming jobs that need a fine touch bending mild steel up to 18 ga. Fully adjustable cams for bending from 0° to 135°. Features a ground bed for clean, straight edge forming. Approximate shipping weight: 49 lbs.



Figure 5. 12" hand brake.

## T20881—In-Line Lubricator $\frac{1}{4}$ " NPT

## T20887—Pressure Regulator $\frac{1}{4}$ " NPT

## G6261—Water Filter $\frac{1}{4}$ " NPT

Install an in-line lubricator to apply oil automatically. Install an air regulator right at the tool for precise air control. Install a filter in your air supply line to prevent water from traveling into your expensive air tools, and ruining them.



Figure 6. In-line pneumatic accessories.

## T20554—Compressor Oil 32 Oz

## T20555—Tool Oil 8 Oz

This Porter Cable air compressor and tool oil offers outstanding heat displacement and friction reduction without eating away at O-rings and other rubber components like detergent motor oils.



Figure 7. Air tool oil.

**Call 1-800-523-4777 To Order**

**G8780—Portable hand punch.**

Producing 1 ton of force, this Hand Punch has a 16 gauge capacity in mild steel, brass and aluminum. Much quicker and safer than drilling thin stock and leaves no ragged edges. Includes  $\frac{9}{32}$ " ,  $\frac{1}{8}$ " ,  $\frac{5}{32}$ " ,  $\frac{3}{16}$ " ,  $\frac{7}{32}$ " ,  $\frac{1}{4}$ " and  $\frac{9}{32}$ " dies and wrenches.



**Figure 8. Portable hand punch.**

**H3243—4" Vise Brake**

**H3244—5" Vise Brake**

**H3245—6" Vise Brake**

These accessories are one of the slickest and cheapest tools to accurately bend sheet metal. The dies magnetically mount on the vise jaws. Slide your sheet metal in and bend by tightening the vise! The press fingers are sectional and can be removed allowing small boxes to be made. Great crafter's tool!

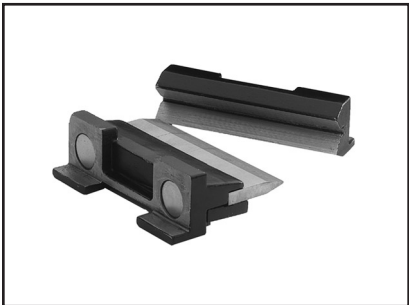

**Figure 9. Vise brake.**

**T10172—Sheet Metal Shrinker Stretcher**

Make smooth radius curves in sheet metal without cutting, welding, heating or hammering. This tool shrinks sheet metal on one side for inside curves and expands sheet metal on the opposite side for outside curves. Handles up to 16 gauge aluminum, 18 gauge mild steel and 20 gauge stainless steel. Great for fabricating fender flanges, collars, and long one-piece strips with various angles.

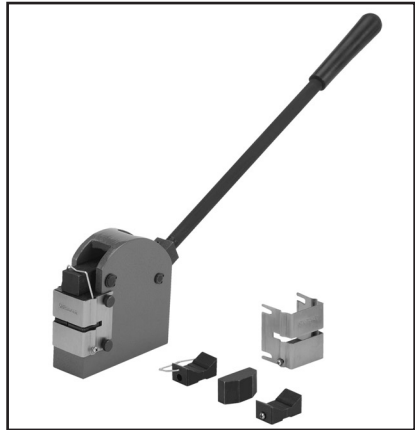

**Figure 10. Sheet metal shrinker stretcher.**

**Call 1-800-523-4777 To Order**

# SECTION 5: MAINTENANCE

## ⚠️ WARNING



**EYE INJURY HAZARD!**  
Wear safety goggles with full eye protection from all sides when using or servicing this shear.

## ⚠️ WARNING



**ACCIDENTAL START HAZARD!**  
Disconnect before service.



**AIR PRESSURE HAZARD!**  
Never exceed max PSI rating for tool.

## Lubrication

In most cases for periodic tool use, manual lubrication is sufficient. However, if the tool is to be used on a consistent basis, we recommend installing an automatic oiler to eliminate dry runs and ensure maximum tool life. The two methods are explained below.

**Manual Lubrication:** Every two hours of use, place a few drops of air tool oil in the air inlet fitting and at all pivot points. Do not use motor oil as the additives can corrode the tool seals. Next, connect the tool to the air line and cover the exhaust port (see **Figure 1**, on **Page 5**) with a rag. Position the end of the tool safely away from you, and run the tool for 30 seconds to completely circulate the oil through the tool and into the rag.

**Automatic Lubrication:** Adjust the automatic in-line oiler. Place a sheet of paper next to the exhaust port, run the tool at three or four 30-second intervals. When finished, the paper should show a slight oil stain. If no oil is seen or excessive oil drips from the paper, adjust the oiler and repeat this process until the adjustment is correct. See **Figure 3** for location.

## Daily Maintenance

### Before and after each use:

- Check and replace any leaking air fittings; bubbled, cut, or worn hoses.
- Drain water from the compressor tank, water filter separator reservoirs, and lubricate the pneumatic shear.

### Periodically as required:

- Clean the filter screen behind the air inlet fitting (see **Figure 1**).
- If used, check and adjust any automatic in-line oiler as required to maintain a fine oil mist at the tool.
- Sharpen dulled jaws edges by removing both jaw retaining cap screws (see **Figure 1**), and the jaws. Next use a dressing stone at the locations shown below. Do not use a grinder.

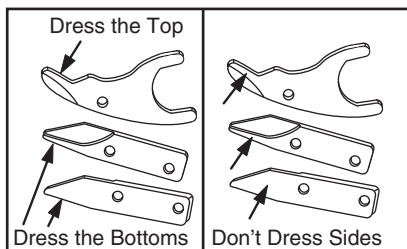

**Figure 11.** Jaw sharpening locations.

# SECTION 6: SERVICE

## Troubleshooting

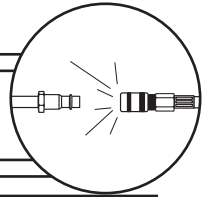

**IMPORTANT: Air tool repairs must be completed by a qualified service person.**

Symptom	Possible Cause	Solution
Tool runs at normal speed but bogs down when cutting, or tool runs slowly with little air exiting the exhaust.	<ol style="list-style-type: none"><li>1. Pneumatic shear is being overloaded.</li><li>2. Jaws are dull or loose.</li><li>3. Trigger is at fault.</li><li>4. Intake filter screen is clogged.</li><li>5. Insufficient air supply volume or pressure.</li><li>6. Incorrect lubrication is affecting tool.</li><li>7. Water is entering tool.</li><li>8. Air tool motor clogged with oil-water sludge.</li></ol>	<ol style="list-style-type: none"><li>1. Reduce feed pressure. Only cut materials within limits of tool.</li><li>2. Dress or replace jaws.</li><li>3. Remove any metal that may be binding trigger from full travel.</li><li>4. Clean the filter screen behind the air supply fitting (see <b>Figure 1</b>, on <b>Page 5</b>).</li><li>5. Set the regulator to 90 PSI, or 100 PSI if the air hose is longer than 25 feet. Repair any leaking fittings, remove all restrictions and hose kinks. Ensure that all hoses and lines have an inside diameter of at least <math>\frac{3}{8}</math>".</li><li>6. Make sure tool is lubricated correctly and does not run dry. Prevent oil from flooding the air tool by re-adjusting the automatic oiler.</li><li>7. Service or reposition the air filter water separator as far as possible from the compressor. This allows for maximum air cooling and water condensation for the water separator.</li><li>8. Clean or rebuild the air tool as required, and correct moisture or lubrication problem in the air supply system.</li></ol>

Symptom	Possible Cause	Solution
Tool does not operate when the trigger is pressed, but air runs freely from exhaust.	<ol style="list-style-type: none"> <li>1. Motor is at fault.</li> <li>2. Motor or gearing is at fault.</li> </ol>	<ol style="list-style-type: none"> <li>1. Motor may be stuck in position from improper storage. Lubricate the air tool, remove the swivel head cap screw and the head. Using a 17mm wrench, rotate the spindle back and forth slightly a few times. Next operate the air tool while re-oiling several times in the process to flush the tool.</li> <li>2. Replace tool.</li> </ol>
Tool runs slowly, and only a small amount of air exits from the exhaust port.	<ol style="list-style-type: none"> <li>1. Air regulator or tool adjustment is at fault.</li> <li>2. Trigger throttle valve is obstructed.</li> <li>3. Intake filter screen is clogged.</li> <li>4. Motor loaded with moisture or oil sludge.</li> </ol>	<ol style="list-style-type: none"> <li>1. Adjust the air regulator to 90 PSI, or 100 PSI if the air hose is longer than 25 feet. Re-adjust the throttle valve screw to the fully open position.</li> <li>2. Disassemble the throttle valve and clean out sludge and contaminants.</li> <li>3. Clean the filter screen behind the air supply fitting (see <b>Figure 1</b>, on <b>Page 5</b>).</li> <li>4. Disassemble air tool, clean, and relubricate. Lubricate air tool and rotate spindle by hand a few times. Next use the trigger to operate the air tool, re-oiling several times in the process to flush the system.</li> </ol>
Tool does not shut <b>OFF</b> when trigger is released.	<ol style="list-style-type: none"> <li>1. Trigger binding or throttle valve at fault.</li> <li>2. Throttle valve stuck open.</li> </ol>	<ol style="list-style-type: none"> <li>1. Remove matter that is binding trigger, so throttle valve is free to fully release.</li> <li>2. Replace throttle valve spring or O-rings.</li> </ol>
Air tool becomes hot or noisy during operation.	<ol style="list-style-type: none"> <li>1. Air tool heats up from insufficient lubrication or a worn bearing.</li> </ol>	<ol style="list-style-type: none"> <li>1. Repair air tool, and correct in-line oiler lubrication adjustment, or follow manual lubrication requirements.</li> </ol>
Air tool becomes too cold to hold, or ice crystals form at exhaust port.	<ol style="list-style-type: none"> <li>1. The intake of moisture and the pressure drop is causing moisture to freeze in the tool.</li> </ol>	<ol style="list-style-type: none"> <li>1. Keep compressor tank drained, service, reposition, or add additional water separators in the supply system.</li> </ol>

# SECTION 7: PARTS

## Main Parts Diagram

*Parts breakdown provided for reference only. Not all parts shown are available for purchase.*

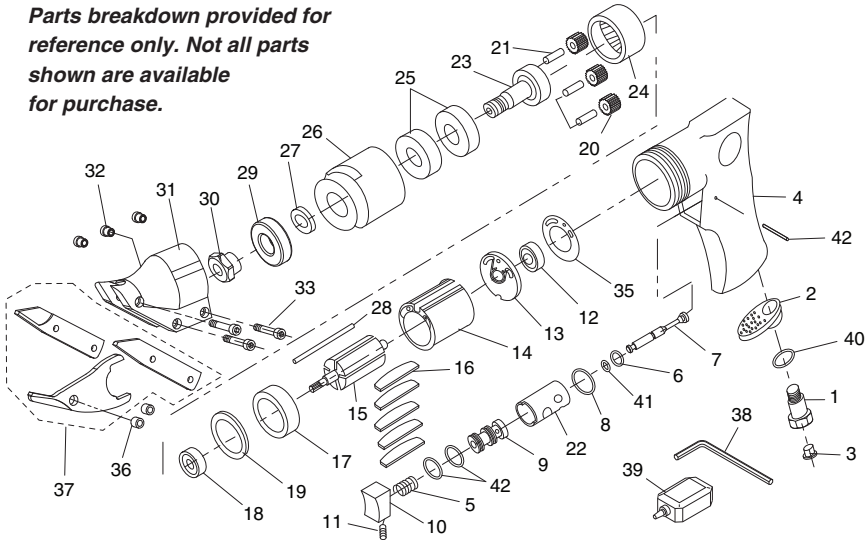

## Main Parts List

REF	PART #	DESCRIPTION
1	N/A	AIR INLET
2	N/A	EXHAUST SLEEVE
3	N/A	DUST PLUG
4	N/A	MOTOR HOUSING
5	N/A	COMPRESSION SPRING
6	N/A	O-RING 4 X 2MM
7	N/A	VALVE STEM
8	N/A	O-RING 12 X 3MM
9	N/A	SPOOL VALVE
10	N/A	TRIGGER
11	PSS51M	SET SCREW M4-.7 X 8
12	P626ZZ	BALL BEARING 626 ZZ
13	N/A	REAR END PLATE
14	N/A	CYLINDER
15	N/A	ROTOR
16	N/A	ROTOR BLADE
17	N/A	FRONT END PLATE
18	P626ZZ	BALL BEARING 626 ZZ
19	N/A	GASKET
20	N/A	PINION GEAR
21	N/A	GEAR PIN

REF	PART #	DESCRIPTION
22	N/A	THROTTLE CYLINDER
23	N/A	SHAFT
24	N/A	INTERNAL RING GEAR
25	P6201Z	BALL BEARING 6201 Z
26	N/A	CLAMP NUT
27	N/A	THRUST SPACER
28	N/A	PIN
29	N/A	BALL BEARING R8Z
30	N/A	ECCENTRIC NUT
31	N/A	HEAD
32	N/A	BARREL LOCK NUT
33	PCAP95M	CAP SCREW M5-.8 X 30
34	N/A	TRIGGER PIN
35	N/A	SEAL PLATE
36	N/A	SLEEVE
37	N/A	JAW SET 3-PC
38	PAW04M	HEX WRENCH 4MM
39	N/A	BOTTLE FOR OIL
40	N/A	O-RING 10.6 X 1.8MM
41	N/A	O-RING 4 X 1.1MM
42	N/A	O-RING 11.5 X 1.8MM

# WARRANTY

---

---

Grizzly Industrial, Inc. warrants every product it sells for a period of **1 year** to the original purchaser from the date of purchase. This warranty does not apply to defects due directly or indirectly to misuse, abuse, negligence, accidents, repairs or alterations or lack of maintenance. This is Grizzly's sole written warranty and any and all warranties that may be implied by law, including any merchantability or fitness, for any particular purpose, are hereby limited to the duration of this written warranty. We do not warrant or represent that the merchandise complies with the provisions of any law or acts unless the manufacturer so warrants. In no event shall Grizzly's liability under this warranty exceed the purchase price paid for the product and any legal actions brought against Grizzly shall be tried in the State of Washington, County of Whatcom.

We shall in no event be liable for death, injuries to persons or property or for incidental, contingent, special, or consequential damages arising from the use of our products.

To take advantage of this warranty, contact us by mail or phone and give us all the details. We will then issue you a "Return Number," which must be clearly posted on the outside as well as the inside of the carton. We will not accept any item back without this number. Proof of purchase must accompany the merchandise.

The manufacturers reserve the right to change specifications at any time because they constantly strive to achieve better quality equipment. We make every effort to ensure that our products meet high quality and durability standards and we hope you never need to use this warranty.

Please feel free to write or call us if you have any questions about the machine or the manual.

Thank you again for your business and continued support. We hope to serve you again soon.