

# HUFFY<sup>®</sup>SPORTS

## Portable System Owners Manual

Customer Service Center

• N53 W24700 South Corporate Circle • Sussex, WI 53089 • U.S.A.

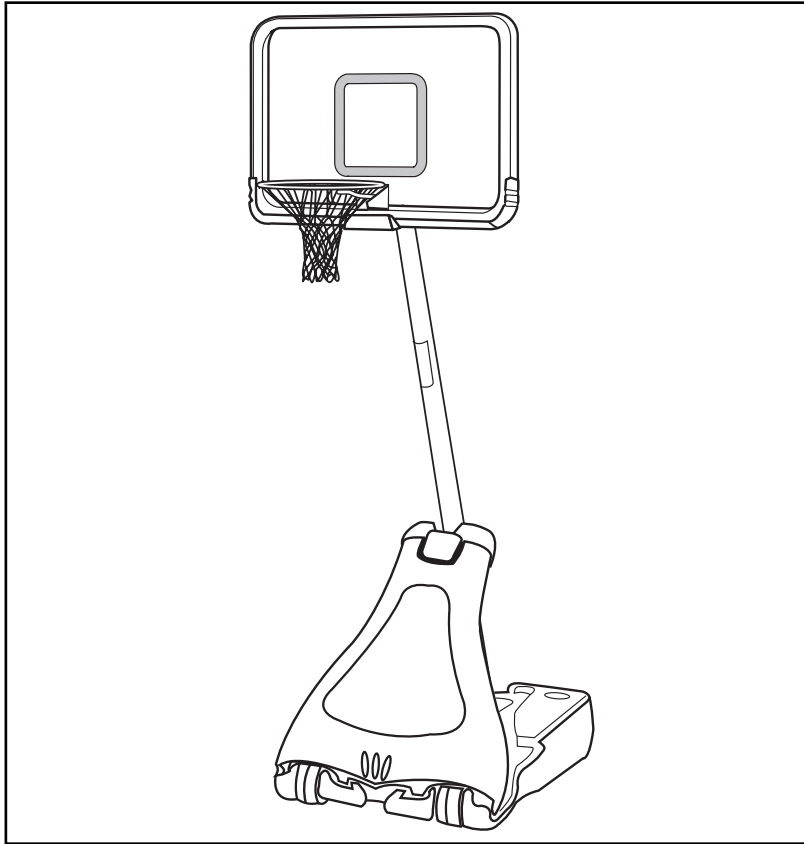

### **! WARNING**

Read and understand operator's manual before using this unit.

Failure to follow operating instructions could result in injury or damage to property.

### **REQUIRED TOOLS AND MATERIALS:**

- Two People
- Tape Measure
- Wood Board (Scrap)
- Wrenches: (Two) 7/16", 1/2", 9/16", 3/4" or Large and Small Adjustable Wrenches
- Safety Goggles
- Sawhorse or Support Table
- Step Ladder 8 ft. (2.4 m)
- Garden Hose or Sand (225 lb.) (102 kg)
- Hammer
- Tape
- Phillips Head Screw Driver

Toll-Free Customer Service Number for U.S: **1-800-558-5234**,

For Canada: **1-800-284-8339**,

For Europe: **00 800 555 85234** (Sweden: **009 555 85234**),

For Australia: **1-800-333 061**

Internet Address: <http://www.huffysports.com>

# BEFORE YOU START!

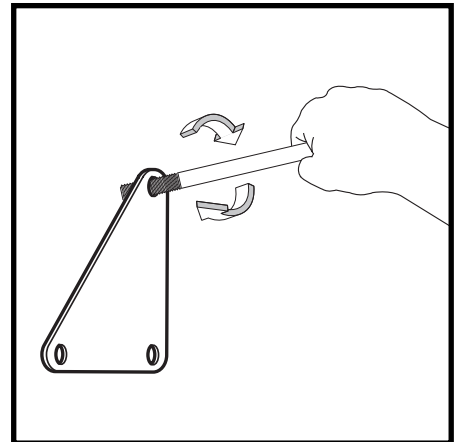
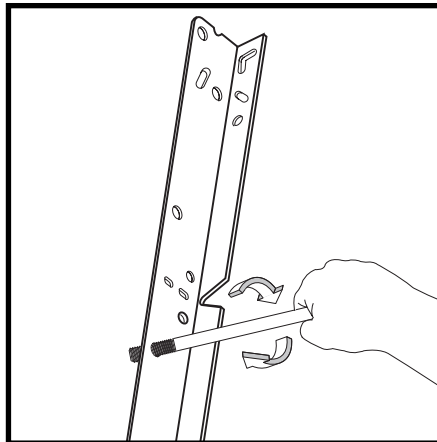
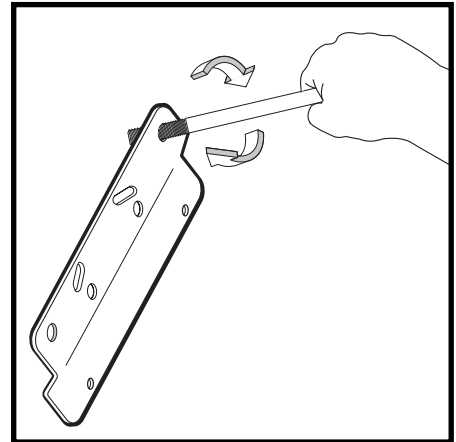
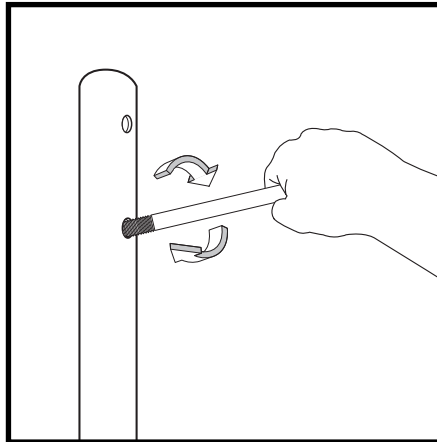

**To ensure optimal playability of backboard system, a close tolerance fit between the elevator components and hardware is required. Test-fit large bolts into large holes of elevator tubes, backboard brackets, and triangle plates. Carefully rock them in a circular motion to ream out any excess paint from holes if necessary.**

## **AVANT DE COMMENCER !**

Pour garantir l'utilisation optimale du panneau, les composants du système élévateur et la visserie doivent être bien ajustés (serrés). À titre d'essai, insérez les gros boulons dans les gros trous des tubes du système élévateur, des supports du panneau et des plaques triangulaires. Basculez-les avec précaution en imprimant un mouvement circulaire pour éliminer l'excédent de peinture, si nécessaire.

## **¡ANTES DE COMENZAR!**

Para asegurar el óptimo rendimiento del sistema del respaldo en el juego, se requiere un ajuste de tolerancia estrecha entre los componentes del elevador y el herraje. Pruebe el ajuste de los pernos grandes en los orificios grandes de los tubos elevadores, soportes del respaldo y placas triangulares. Cuidadosamente muévalos en círculos para eliminar cualquier exceso de pintura, si es necesario.

## **VORBEREITENDE MASSNAHMEN**

Um sicherzustellen, dass das Korbwandssystem optimal für den Spielbetrieb geeignet ist, müssen die Komponenten der Verlängerungsvorrichtung und die verschiedenen Befestigungsteile fest miteinander verschraubt werden. Große Schrauben zur Probe in die großen Löcher der Verlängerungsrohre, Korbwandklammern und Dreiecksplatte stecken und diese vorsichtig in einer Kreisbewegung hin- und herbewegen, um eventuelle Farbrückstände aus den Bohrungen zu entfernen.



# WARNING

**FAILURE TO FOLLOW THESE WARNINGS MAY RESULT  
IN SERIOUS INJURY AND/OR PROPERTY DAMAGE.**

*Owner must ensure that all players know and follow  
these rules for safe operation of the system.*

- **DO NOT HANG** on the rim or any part of the system including backboard, support braces or net.
- During play, especially when performing dunk type activities, keep player's face away from the backboard, rim and net. Serious injury could occur if teeth/face come in contact with backboard, rim or net.
- Do not slide, climb, shake or play on base and/or pole.
- After assembly is complete, fill system completely with water or sand and stake to the ground. Never leave system in an upright position without filling base with weight, as system may tip over causing injuries.
- When adjusting height or moving system, keep hands and fingers away from moving parts.
- Do not allow children to move or adjust system.
- During play, do not wear jewelry (rings, watches, necklaces, etc.). Objects may entangle in net.
- Surface beneath the base must be smooth and free of gravel or other sharp objects. Punctures cause leakage and could cause system to tip over.
- Keep organic material away from pole base. Grass, litter, etc. could cause corrosion and/or deterioration.
- Check pole system for signs of corrosion (rust, pitting, chipping) and repaint with exterior enamel paint. If rust has penetrated through the steel anywhere, replace pole immediately.
- Check system before each use for proper ballast, loose hardware, excessive wear and signs corrosion and repair before use.
- Check system before each use for instability.
- Do not use system during windy and/or severe weather conditions; system may tip over. Place system in the storage position and/or in an area protected from the wind and free from personal property and/or overhead wires.
- Never play on damaged equipment.
- See instruction manual for proper installation and maintenance.
- When moving system, use caution to keep mechanism from shifting.
- Keep pole top covered with cap at all times.
- Do not allow water in tank to freeze. During sub-freezing weather add non-toxic antifreeze, sand or empty tank completely and store. (Do not use salt.)
- Use extreme caution if placing system on sloped surface. System may tip over more easily.

**HUFFY® SPORTS**

In the U.S.: 1-800-558-5234 and Canada: 1-800-284-8339

201241 2/99



# SAFETY INSTRUCTIONS



FAILURE TO FOLLOW THESE SAFETY INSTRUCTIONS MAY RESULT IN SERIOUS INJURY OR PROPERTY DAMAGE AND WILL VOID WARRANTY.

*Owner must ensure that all players know and follow these rules for safe operation of the system.*

To ensure safety, do not attempt to assemble this system without following the instructions carefully. Check entire box and inside all packing material for parts and/or additional instruction material. Before beginning assembly, read the instructions and identify parts using the hardware identifier and parts list in this document. Proper and complete assembly, use, and supervision are essential for proper operation and to reduce the risk of accident or injury. A high probability of serious injury exists if this system is not installed, maintained, and operated properly.

- If using a ladder during assembly, use extreme caution.
- Two (2) people are recommended for this operation.
- Check base regularly for leakage. Slow leaks could cause system to tip over unexpectedly.
- Seat the pole sections properly (if applicable). Failure to do so could allow the pole sections to separate during play and/or transport of the system.
- Climate, corrosion, or misuse could result in system failure.
- Minimum operational height is 6' 6" (1.98 m) to the bottom of backboard.
- This equipment is intended for home recreational use only and NOT excessive competitive play.
- Read and understand the warning label affixed to pole. Label is shown below.
- The life of your basketball pole depends on many conditions. The climate, placement of the pole, location of the pole, exposure to corrosives such as pesticides, herbicides, or salts are all important.
- If technical assistance is required, contact Huffy Sports.
- Adult supervision is recommended when adjusting height.

*Most injuries are caused by misuse and/or not following instructions.  
Use caution when using this system.*

## HEIGHT ADJUSTMENT

### TO ADJUST BACKBOARD:

1. While holding handle, remove pin.
2. Move elevator up or down to desired height.
3. Replace pin full length to lock system at desired height.

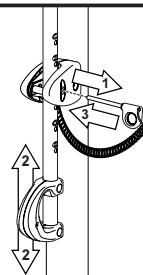

54

## MOVING SYSTEM

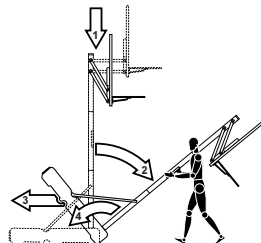

1. Adjust basketball backboard height to lowest position.
2. While holding pole, rotate basketball system forward until wheels engage with ground.
3. Move basketball system to desired location.
4. Carefully rotate basketball system upright.
5. Reattach ground restraint and check system for stability.

201252 2/99



**Questions or Missing Parts?**

**DON'T go back to store!**

Call TOLL-FREE Customer Service  
Number listed on the front page!

### **NOTICE TO ASSEMBLERS**

**ALL Huffy Sports Basketball Systems, including those used for DISPLAYS, MUST be assembled and ballasted with sand or water according to the instructions. Failure to follow instructions could result in SERIOUS INJURY. It is NOT acceptable to devise a makeshift weight system.**

### **IMPORTANT!**

**Remove all contents from boxes.  
Be sure to check inside pole sections;  
hardware and additional parts are packed inside.**

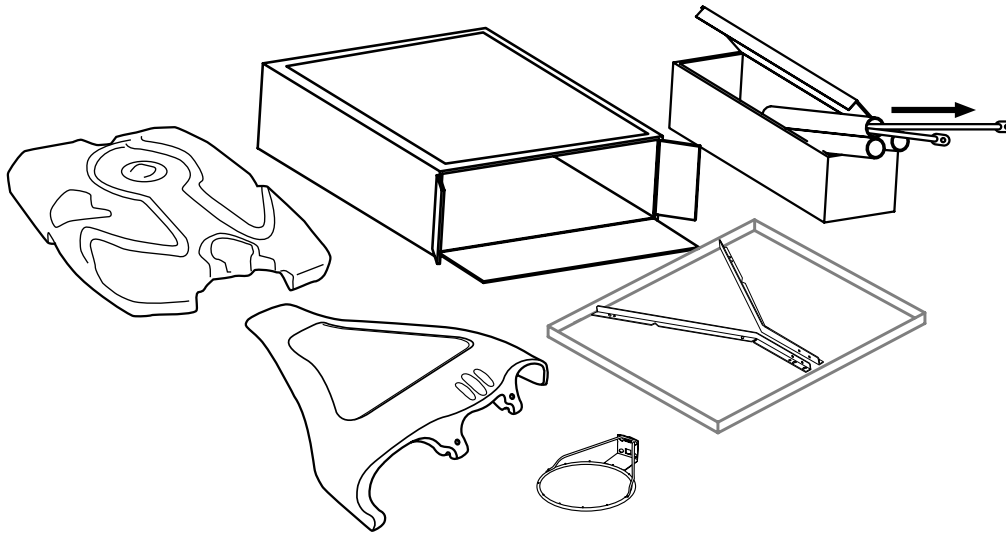

#### **WARRANTY CARD:**

Please remember to complete your product registration form either on-line at:  
**[www.huffysports.com](http://www.huffysports.com)** or mail-in the enclosed postcard.

For more information on assembly, placement, proper use, and maintenance, visit The American Basketball Council website at <http://www.smarthoops.com>.

*Get to know the basic parts of your basketball system.....*

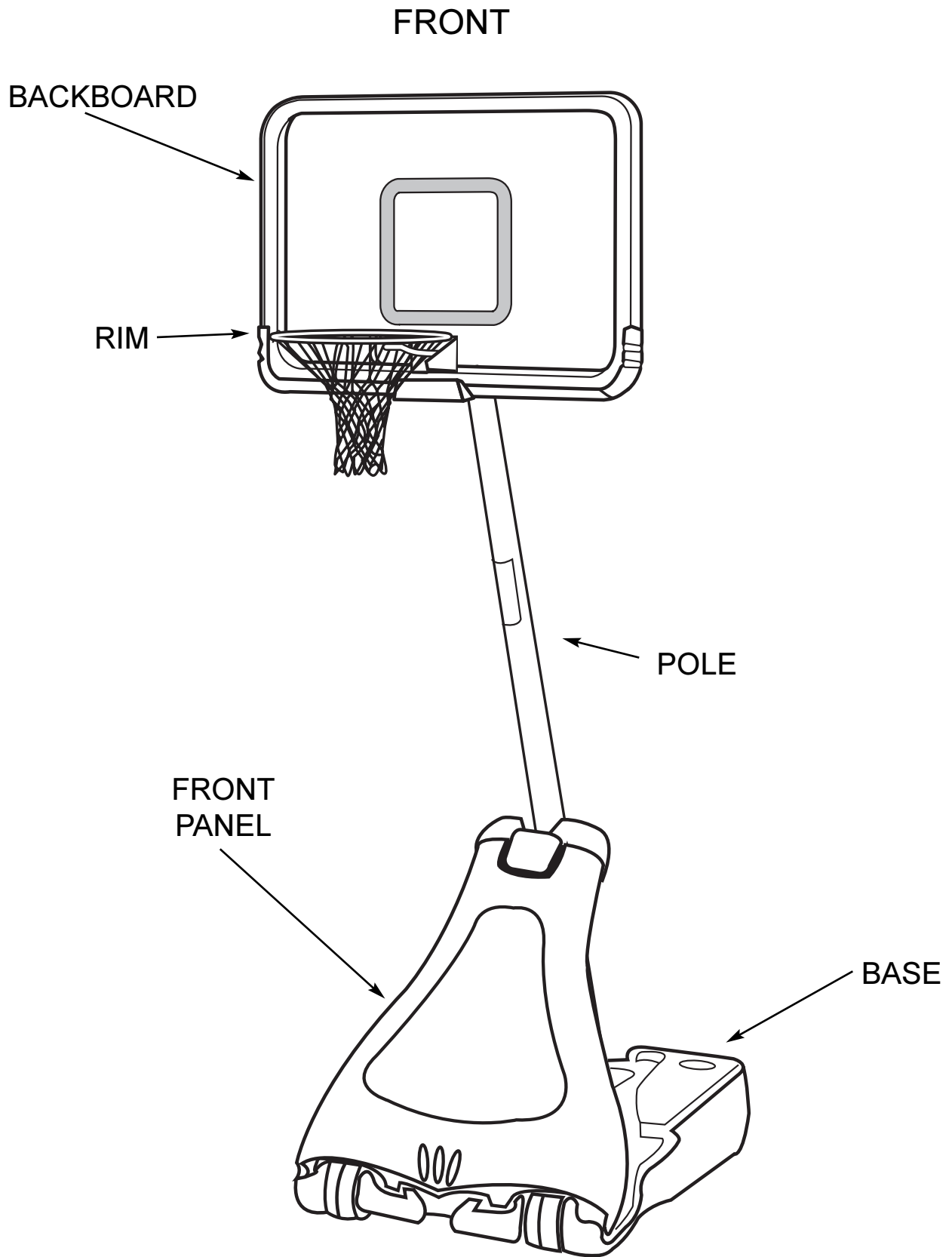

## PARTS LIST - (See Hardware Identifier)

<u>Item</u>	<u>Qty.</u>	<u>Part No.</u>	<u>Description</u>	<u>Item</u>	<u>Qty.</u>	<u>Part No.</u>	<u>Description</u>
1	1	206620	Tank	31	1	204803	Screw, Phillips Head
2	2	203451	Wheel Axle, 13-5/8 Long	32	1	204855	Handle, Left
3	2	226404	Wheel, 6" (Black)	33	1	204856	Handle, Right
4	1	908006	Top Pole Section	34	4	201683	Spacer, .530 I.D. x 1.5 Long
5	1	908107	Middle Pole Section	35	2	200964	Bracket, Backboard Support
6	1	908005	Bottom Pole Section	36	2	200874	Spacer, Steel .402 I.D. x .5 O.D. x 1.5 Long
7	4	203223	Bolt, Carriage 5/16-18 x 1	37	6	206244	Bolt, Hex Head, 1/2-13 x 8 Long
8	2	206934	Large Eyebolt, 3/8"	38	4	201642	Spacer, Plastic, .530 I.D. x .625 Long
9	1	201581	Pole Mount Bracket	39	7	206340	Lock Nut, Hex Head, 1/2-13
10	2	203063	Nylon Insert Lock Nut, 3/8-16	40	2	904820	Elevator Tube, Lower - Long
11	1	206634	Rod, 1/2 x 9-1/2 Long	41	1	204837	Spring, Counter Balance
12	1	203099	Nut, Ny-lock, 5/16-18	42	1		Rim
13	6	203218	Washer, 5/16 Flat	43	2	904808	Elevator Tube, Upper - Short
14	1	202662	Bolt, Hex Head, 5/16-18 x 4-1/2 Long	44	2	201682	Spacer, .530 I.D. x 1.875
15	2	200341	Bolt Cover	45	2	900867	Plate, Triangle, (Black)
16	11	203100	Hex Flange Nut 5/16-18	46	1	207103	Cap, Pole Top
17	1	204832	Bracket, Pole Mount	47	1	206002	Front Cover
18	2	203053	Carriage Bolt, 5/16-18 x 4 Long	48	1	202856	Bolt, Hex, 1/2-13 x 4 Long
19	4	203232	Washer, Metal, 3/4" O.D.	49	1	206219	Plug, Tank Cap
20	4	201124	Lock Nut, 3/8-16	50	12*	201219	Net Clip, (White)
21	4	206360	Bolt, Hex Head, 3/8-16 x 2-5/8 Long	51	1	204290	Net
22	2	204858	Spacer, Plastic Biscuit	52	1	204444	Black Nylon Rope
23	2	204857	Spacer, Metal 1/2" O.D. x 1.44 Long	53	1	203124	Stake, Tie Down
24	2	204859	Cover, Pin Slide	54	1	201252	Label, Height Adjustment and Moving
25	1	203038	Carriage Bolt, 5/16-18 x 2-3/4 Long	55	6	203309	Washer, .406 I.D. x 1 O.D. Flat
26	1	204850	Pin, Locking	56	4*	205528	Bolt, Hex Flange, 5/16-18 x 1 Long
27	1	204853	Lanyard, Black Coil	57	2	203452	Small Eye Bolt, 5/16-18
28	1	904833	Height Adjustment Rod	58	1	206990	Reinforcement Bracket
29	1	204872	Label, Height Indicator	59	2	200520	Screw, #8 x 1/2
30	2	203103	Carriage Bolt, 5/16-18 x 2 Long	60	1	200503	Cover, Black
				61	4	201681	Spacer, Plastic, .530 I.D. x .88 Long

**NOTE:** Hardware kit is designed for more than one style of basketball system. Not all hardware will be used.

\* YOU MAY HAVE EXTRA PARTS WITH THIS MODEL.

**WARNING:** IF YOUR SYSTEM IS EQUIPPED WITH AN ACRYLIC BACKBOARD, EXAMINE BACKBOARD FOR ANY DAMAGE THAT MAY HAVE OCCURRED DURING SHIPMENT. CRACKS IN THE BACKBOARD COULD RESULT IN SUDDEN BREAKAGE. IF BACKBOARD IS DAMAGED IN ANY WAY PRIOR TO OR AFTER ASSEMBLY, CALL TOLL-FREE NUMBER:  
 U.S. 1-800-558-5234; CANADA: 1-800-284-8339; <http://www.huffysports.com>

# HARDWARE IDENTIFIER (BOLTS & SCREWS)

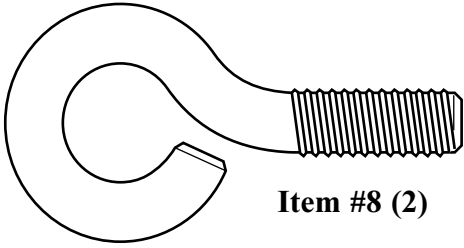

**Item #8 (2)**

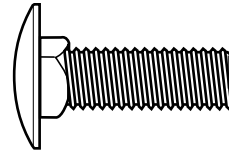

**Item #7 (4)**

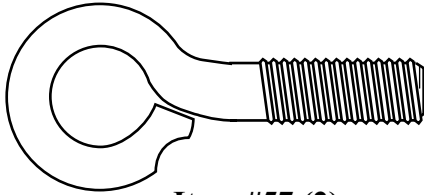

**Item #57 (2)**

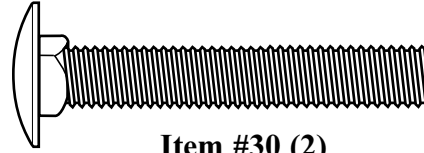

**Item #30 (2)**

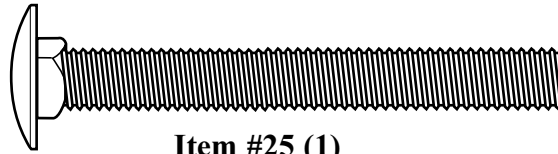

**Item #25 (1)**

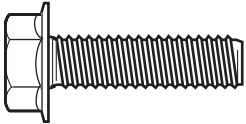

**Item #56 (4)**

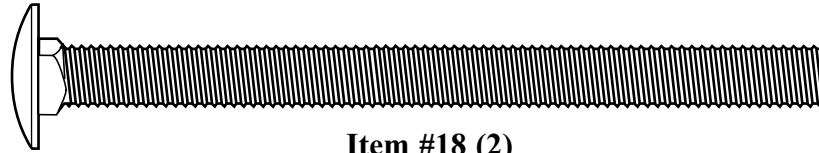

**Item #18 (2)**

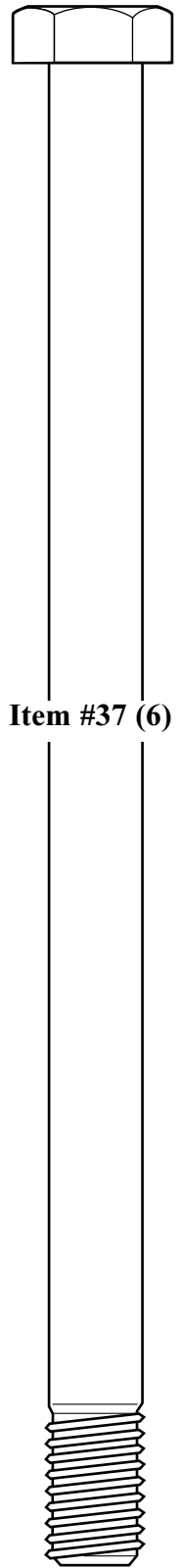

**Item #37 (6)**

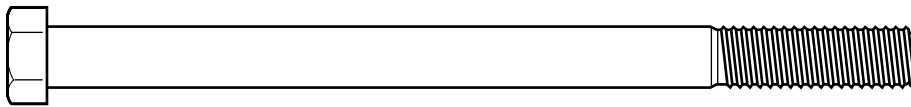

**Item #14 (1)**

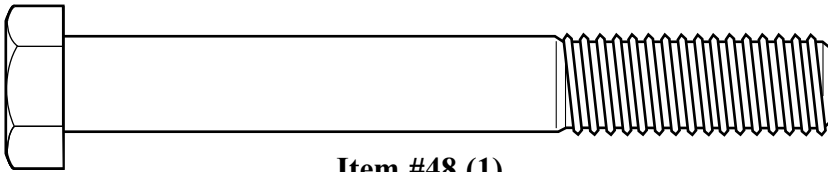

**Item #48 (1)**

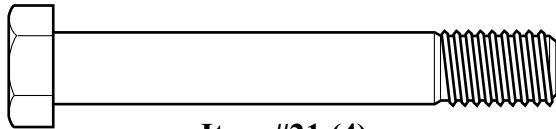

**Item #21 (4)**

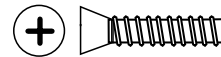

**Item #59 (2)**

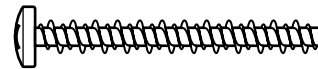

**Item #31 (1)**

\* You may have extra parts with this model.



## HARDWARE IDENTIFIER (STEEL SPACERS)



Item #23 (2)



Item #36 (2)

## HARDWARE IDENTIFIER (NUTS & WASHERS)

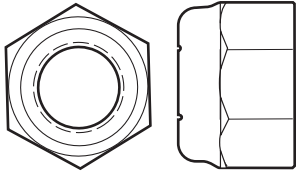

Item #39 (7)

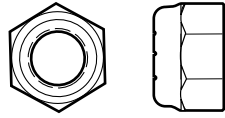

Item #12 (1)

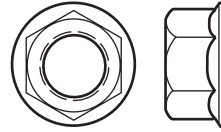

Item #16 (11)

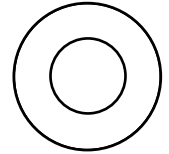

Item #19 (4)

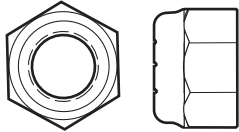

Item #10 (2)

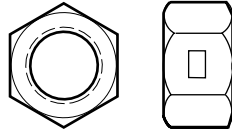

Item #20 (4)

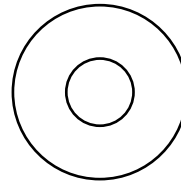

Item #13 (6)

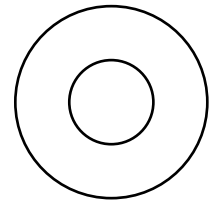

Item #55 (6)

## HARDWARE IDENTIFIER (PLASTIC SPACERS CAPS & CLIPS)

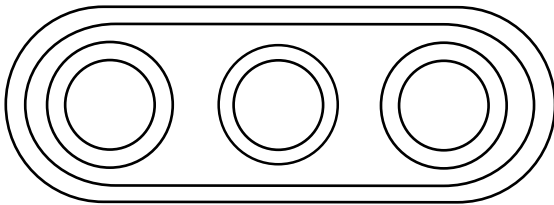

Item #22 (2)

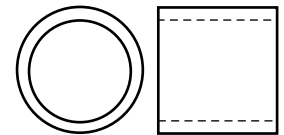

Item #38 (4)

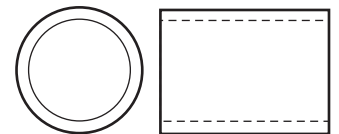

Item #61 (4)

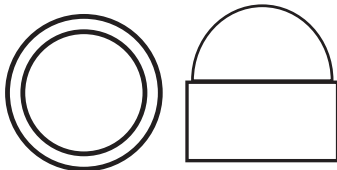

Item #15 (2)



Item #50 (12)\*

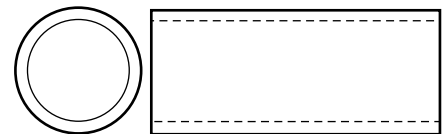

Item #34 (4)

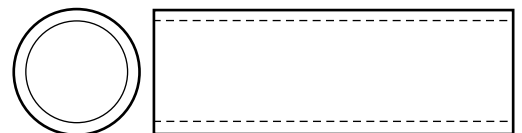

Item #44 (2)

# SECTION A: ASSEMBLE THE BASE

This is what your system will look like when you've finished this section:

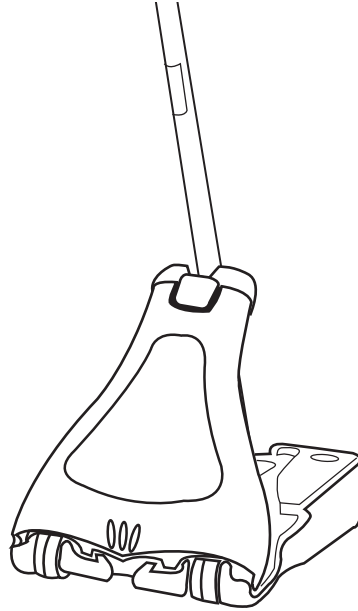

## TOOLS REQUIRED FOR THIS SECTION

(2) 1/2" AND (2) 9/16" Wrenches



AND/OR

(2) Socket Wrenches and Sockets

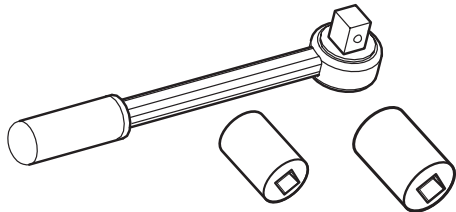

1/2" 9/16"

AND

a Phillips-Head Screwdriver



## HARDWARE USED IN THIS SECTION (not actual size)

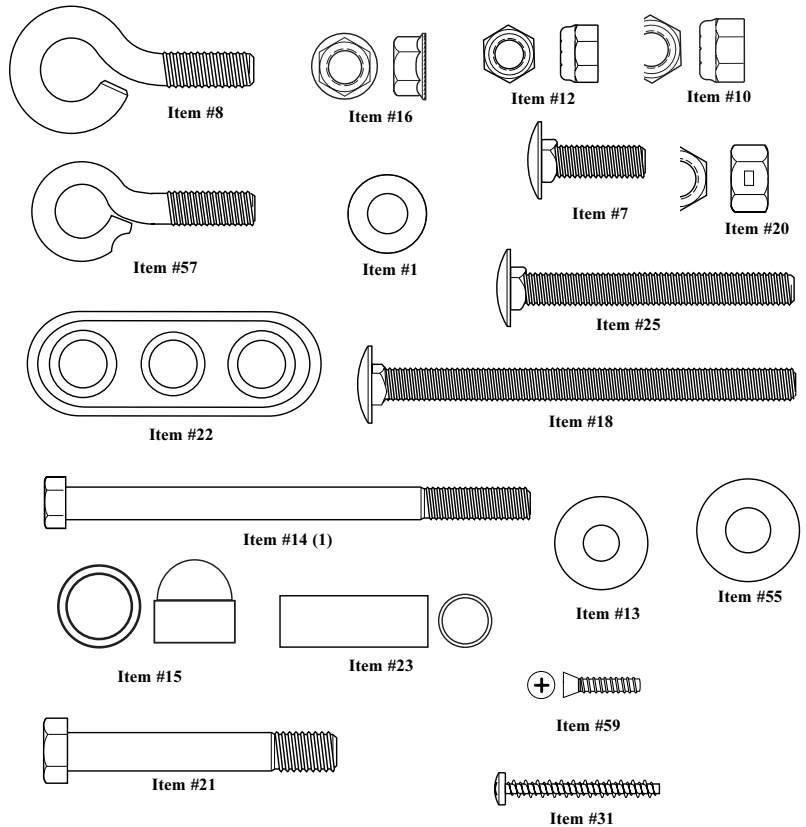

- 1.** Insert axle (2) into tank (1) as shown to secure wheel (3) and small eyebolt (57) into position. Repeat procedure for opposite side.

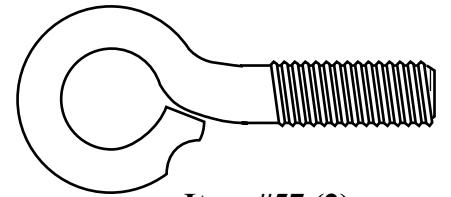
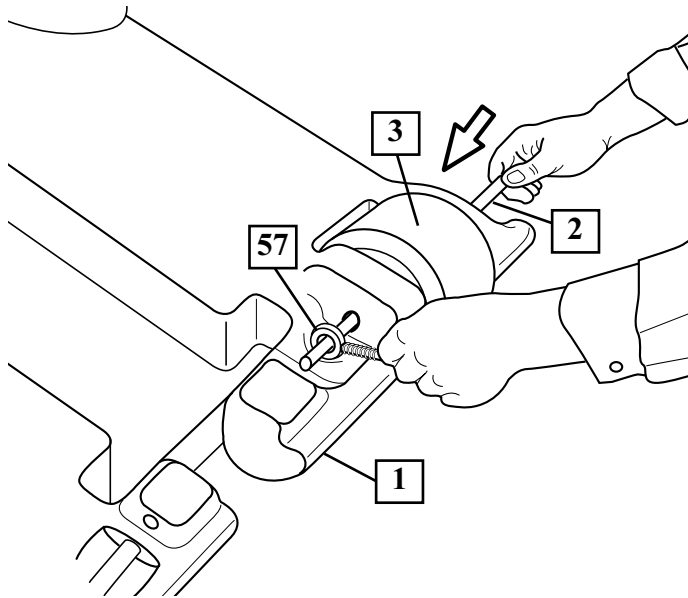

Item #57 (2)

- 2.** Position front cover (47) on top of tank (1) as shown, insert eye bolts (57) through cover, snapping front cover over axles (2) at the same time. Tighten completely.

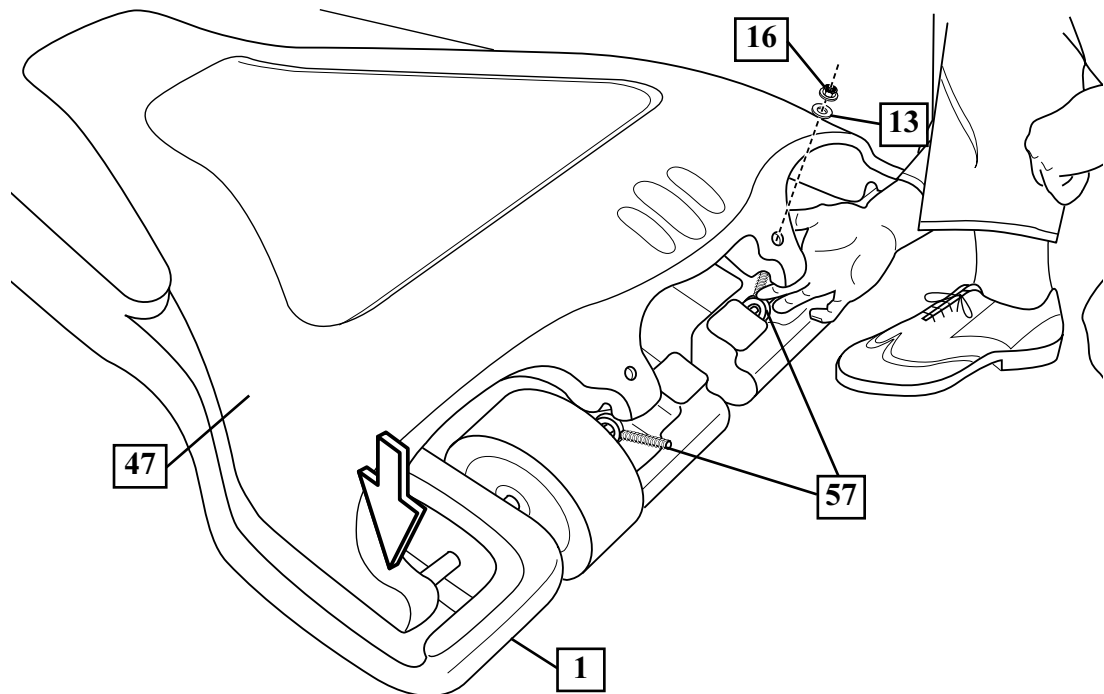

**3.** Mark pole sections with tape (not supplied) as shown.

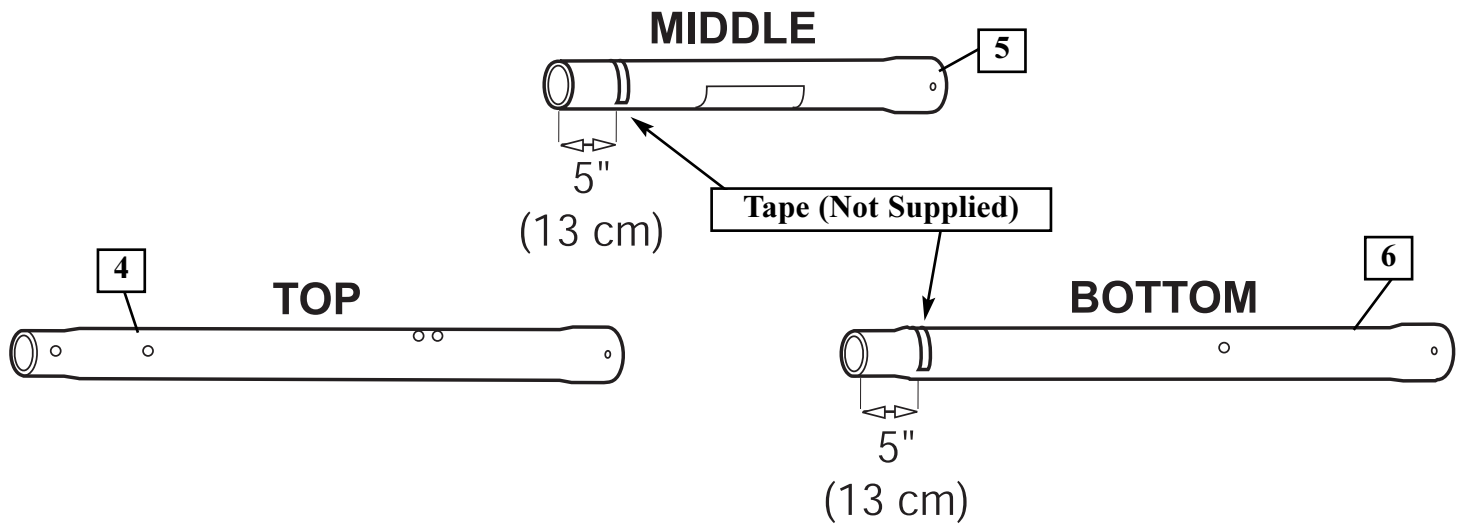

**4. IMPORTANT! Center alignment slot of middle pole section (5) in a lower hole of top pole section (4) as shown.** While maintaining alignment, bounce middle pole section (5) into top section (4) using a wood scrap, as shown, until the top pole no longer moves toward the taped reference mark on the middle pole. Upright assembly.  
**NOTE:** Pole sections should have a 3-1/2" (9 cm) overlap minimum.

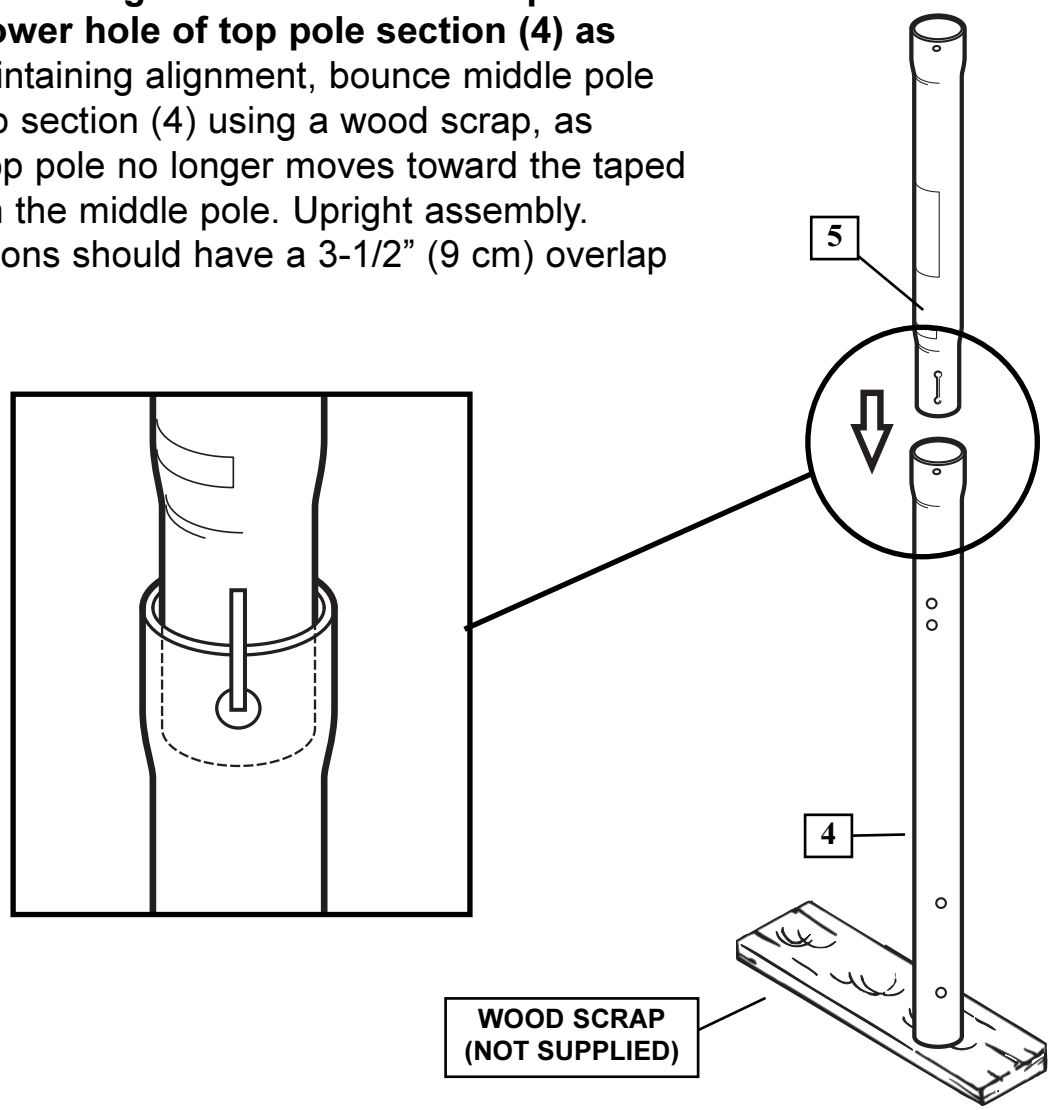

- 5.** Bounce top (4) and middle (5) pole assembly onto bottom pole section (6) using a wood scrap as shown. Bounce until the top and middle pole assembly no longer moves toward the taped reference mark on the bottom pole. **NOTE:** Pole sections should have a 3-1/2" (9 cm) overlap minimum.

**IMPORTANT!:**

Holes in top (4) and bottom pole (6) sections **MUST** align to correctly position elevator system toward playing surface.

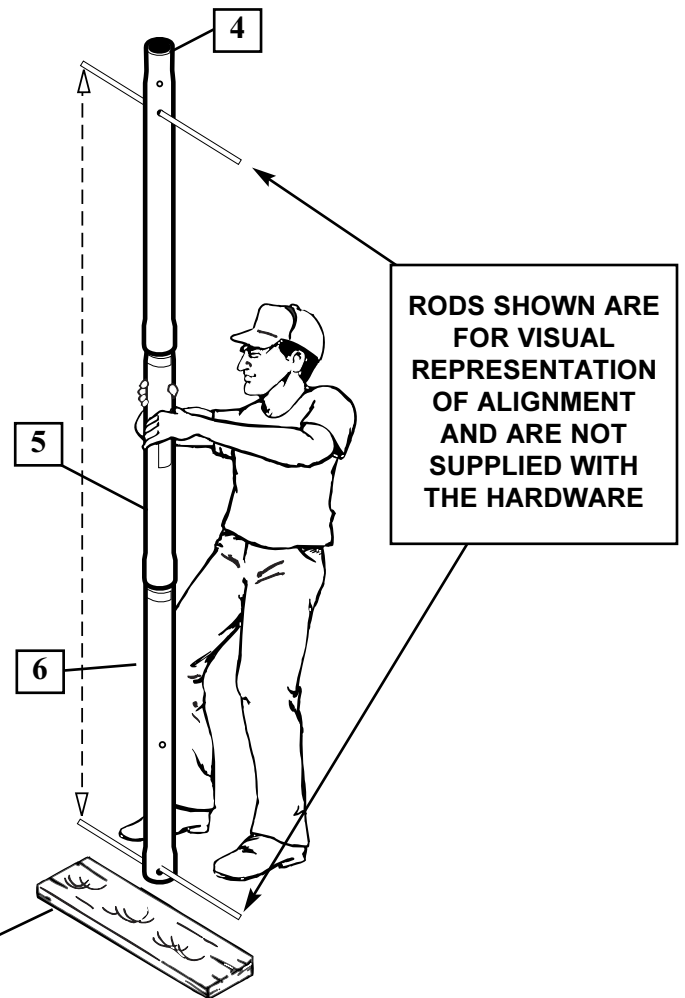

- 6.** Insert bolts (7) into bracket (9) as shown. Install bolt (14) through bracket (9) and bottom pole section (6) and secure with nut (12) as shown.

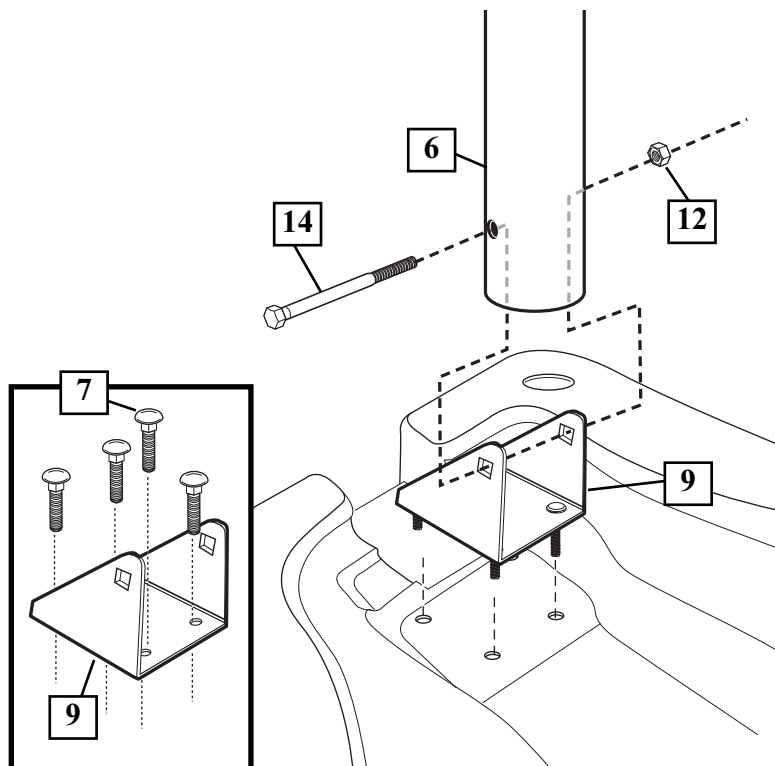

- 7.** Carefully tip unit forward and secure pole assembly to tank (1) with washers (13) and nuts (16) as shown.

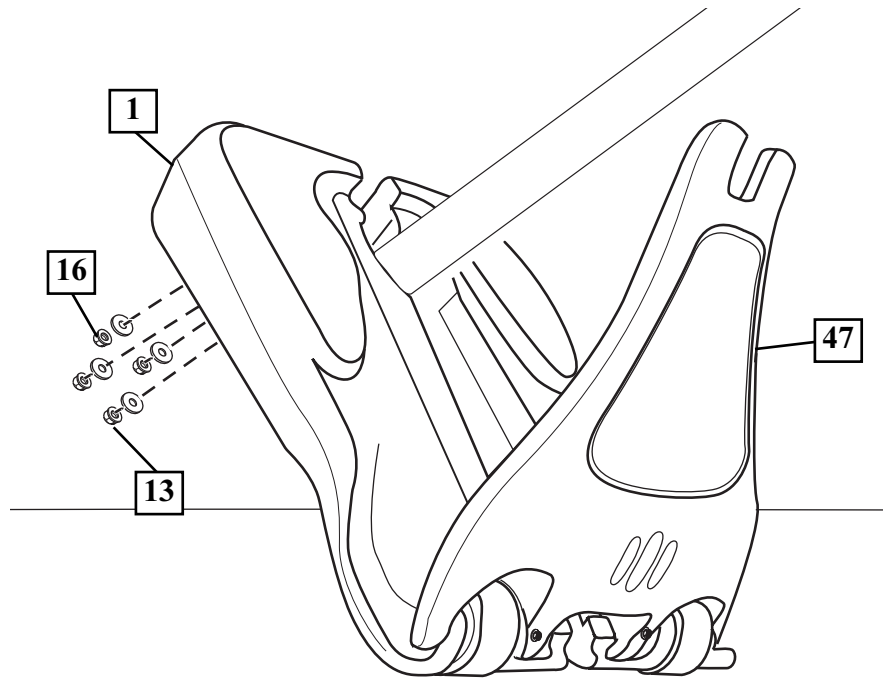

- 8.** Install rod (11) through bottom pole section (6) as shown. Install large eye bolts (8) onto rod (11) as shown.

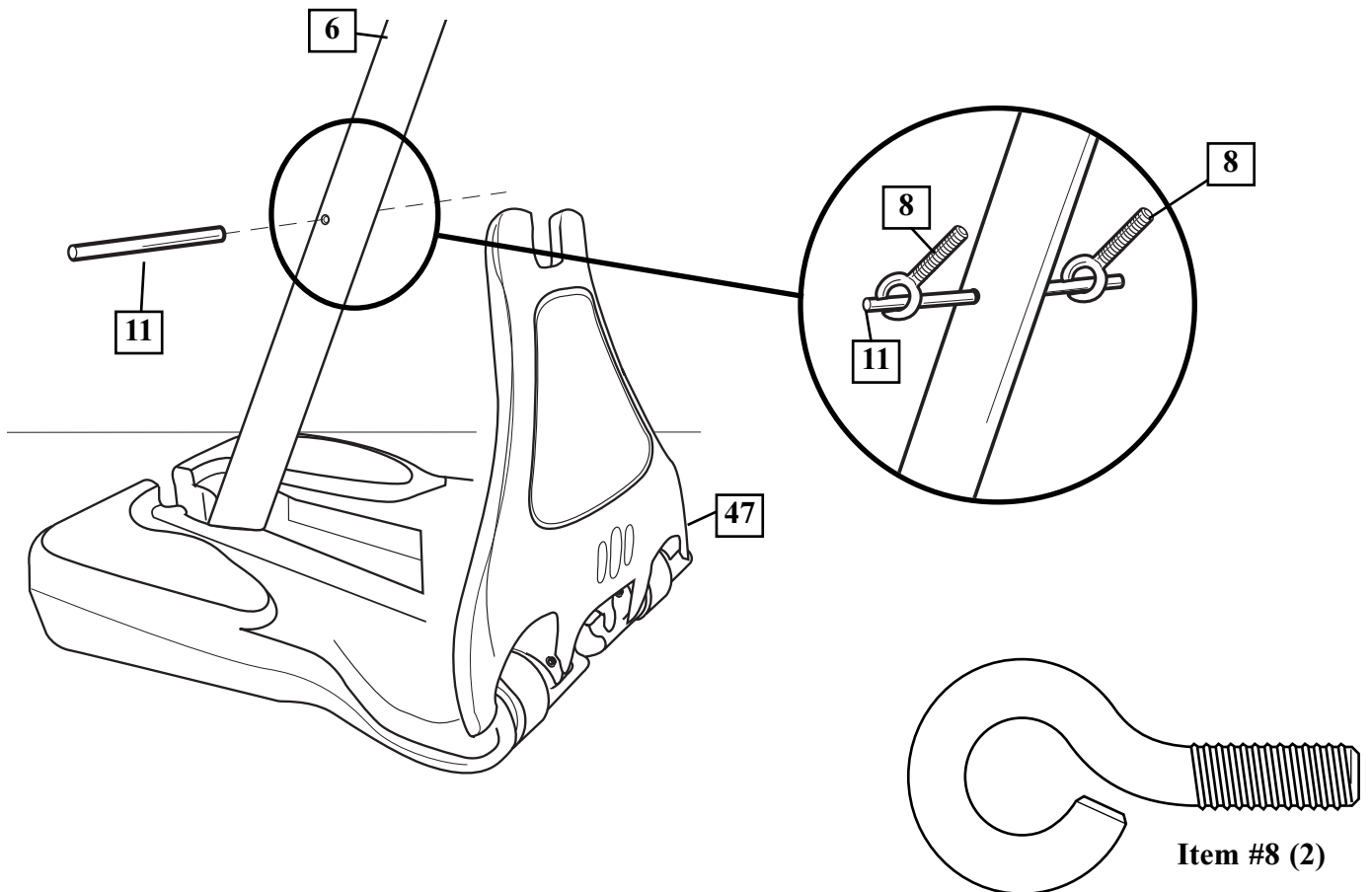

- 9.** Secure cover (47) to rod (11) using washers (55) nuts (10) and bolt covers (15) as shown.

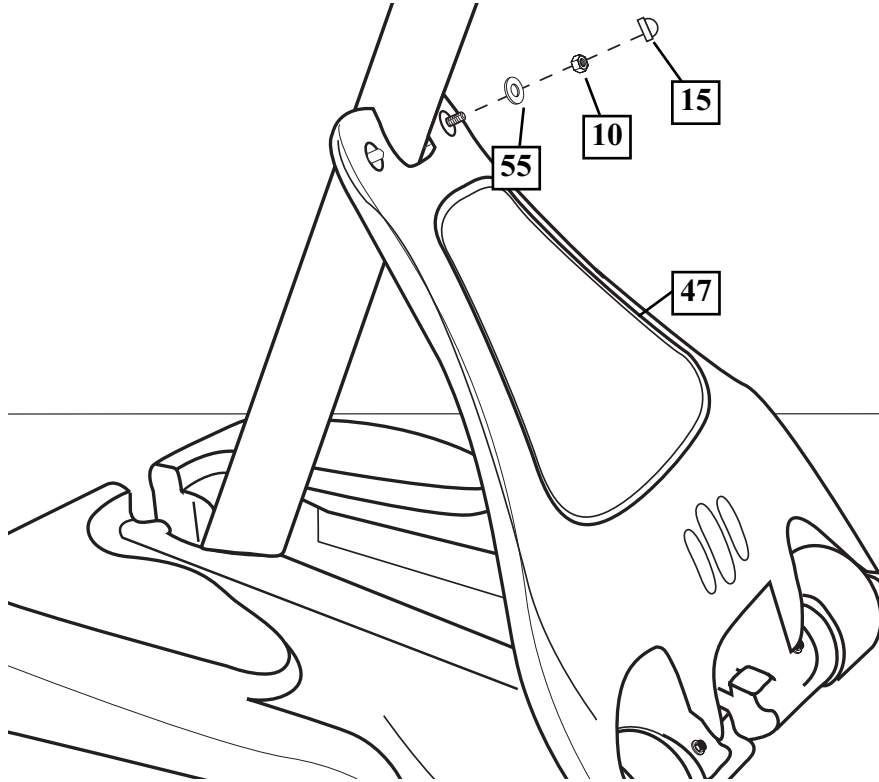

- 10.** Install pole mount bracket (17) and reinforcement bracket (58) with carriage bolts (18) as shown. Tighten flange nuts (16) completely.

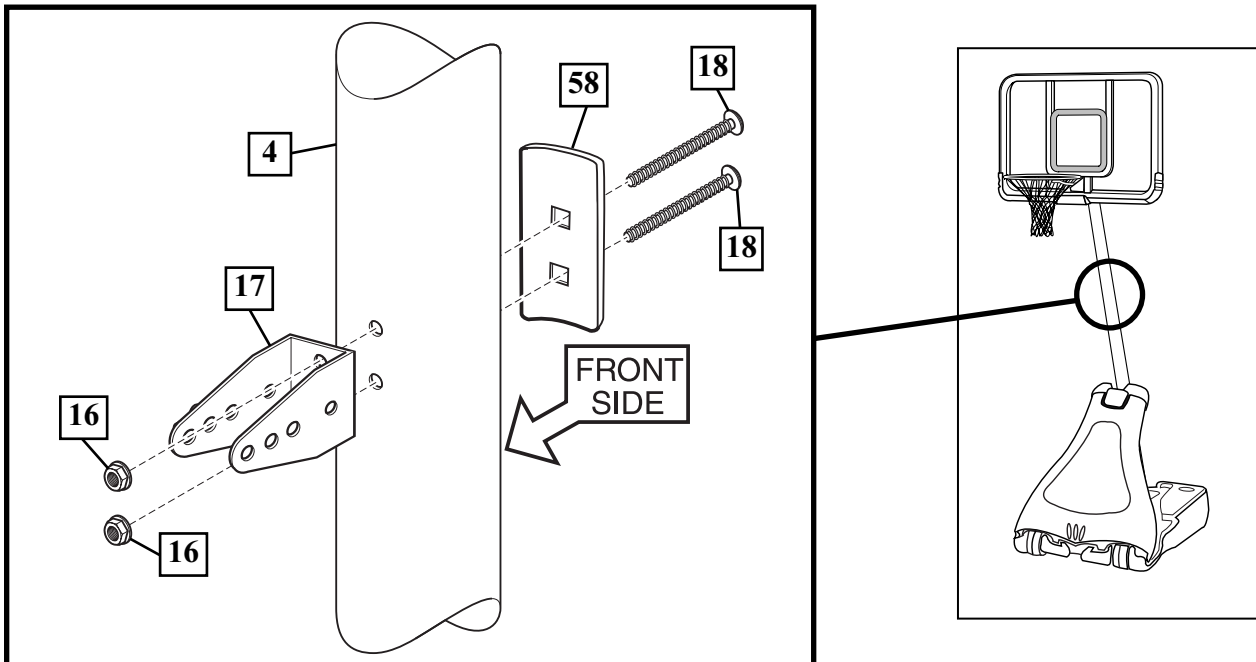

- 11.** Attach spacers (22, 23) to pole mount bracket (17) with bolts (21), washers (19), and nuts (20) as shown. **IMPORTANT! Tighten just until washers (19) stop moving.**

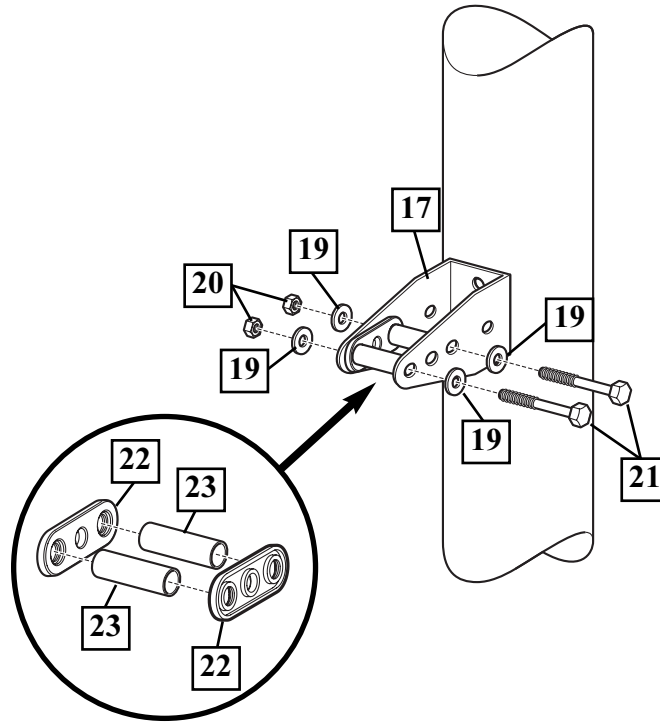

- 12.** Assemble lanyard (27) to locking pin (26) as shown (FIG A). Attach covers (24) onto pole mount bracket (17) with carriage bolt (25) and nut (16) as shown.

**IMPORTANT!:**

Loop end of pin lanyard (27) over carriage bolt (25) as it passes through the pole mount bracket (17) during this assembly. See FIG A.

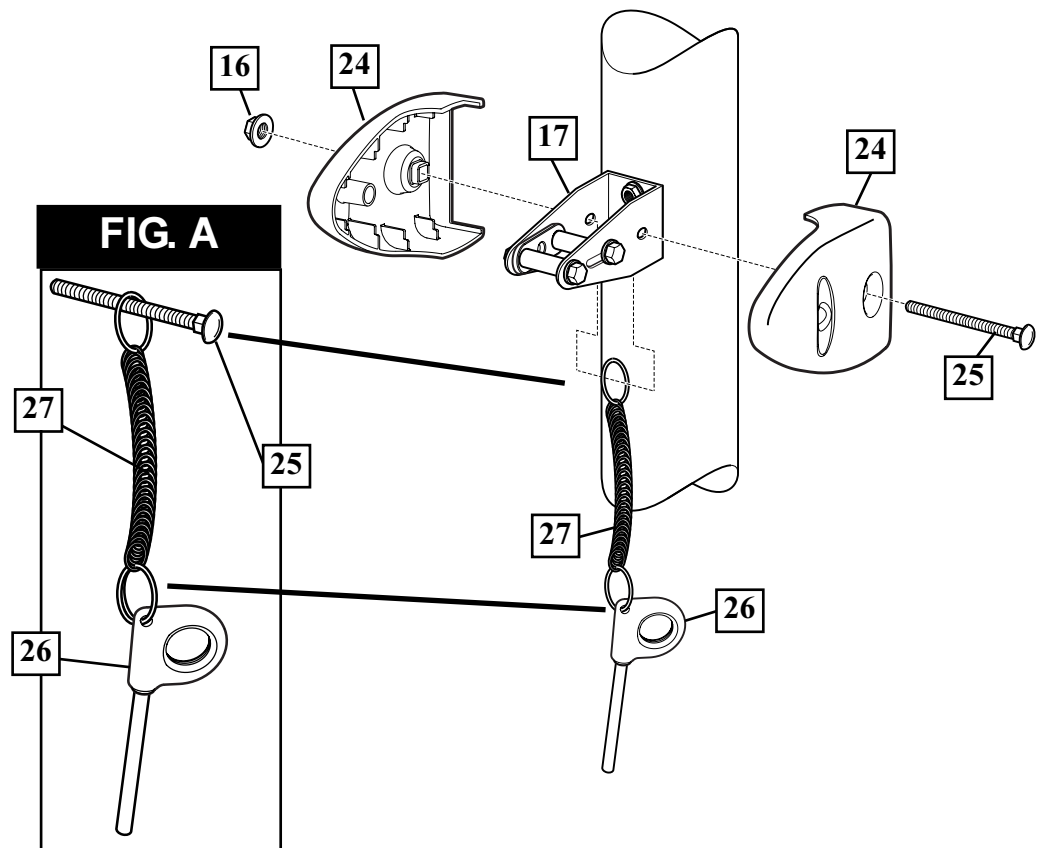



- 13.** Apply logo and height indicator labels (29) to adjustment rod (28) as shown. Attach handle parts (32, 33) to adjustment rod with screw (31), carriage bolts (30), and flange nuts (16) as shown.

**NOTE:** Holes in adjustment rod allow for either rear access or side access.

**IMPORTANT!:**

Indicator labels should be applied as close to holes as possible to prevent labels from being damaged during height adjustment.

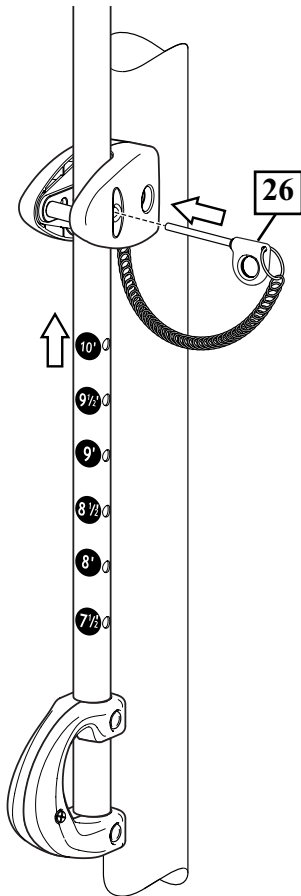
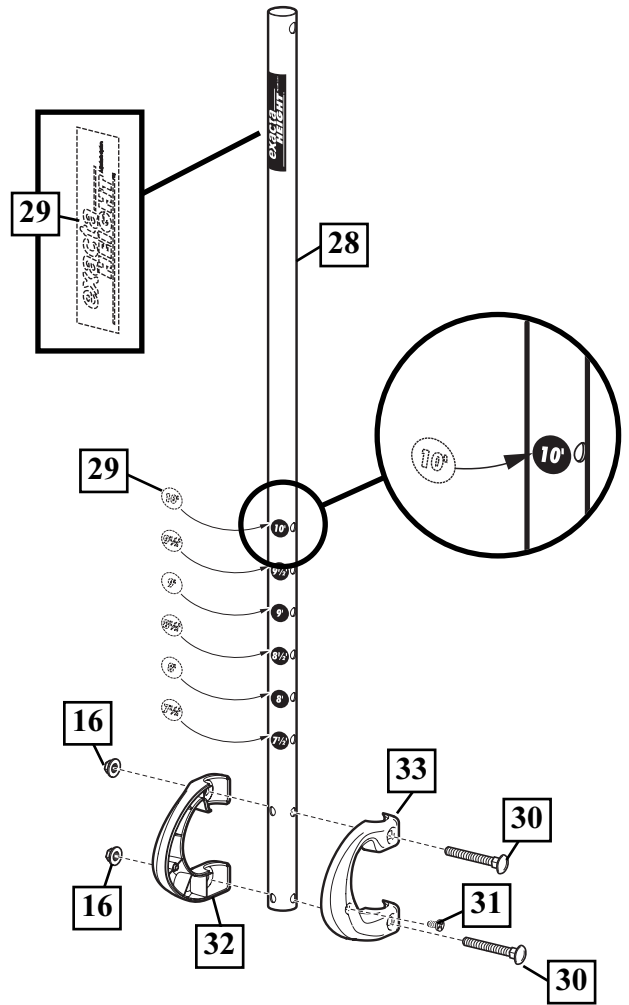
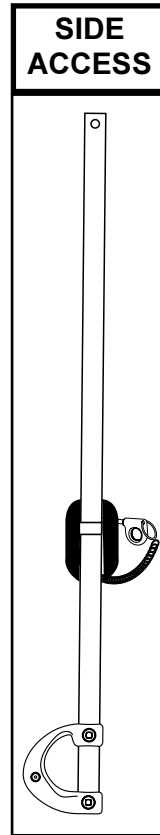

- 14.** Insert handle assembly through pole mount assembly as shown. Lock pole assembly in place at the 10' (3.05 m) mark with pin (26).

# SECTION B: ATTACH THE BACKBOARD

This is what your system will look like when you've finished this section:

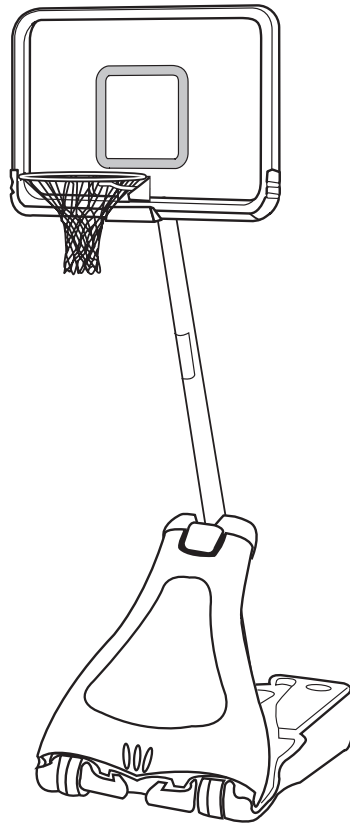

## TOOLS REQUIRED FOR THIS SECTION

(2) 1/2", (2) 9/16" AND (2) 3/4" Wrenches



AND/OR  
(2) Socket Wrenches and Sockets

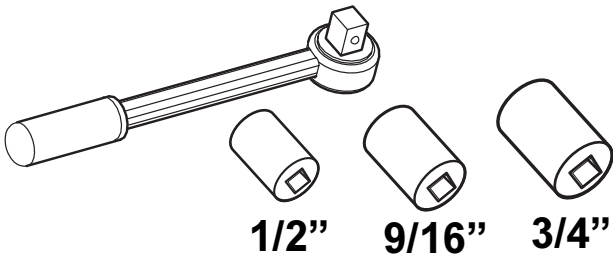

1/2"

9/16"

3/4"

## HARDWARE USED IN THIS SECTION (not actual size)

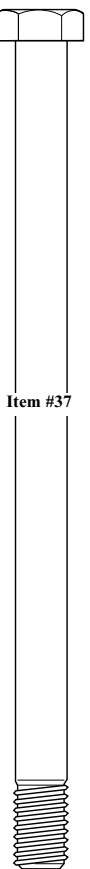
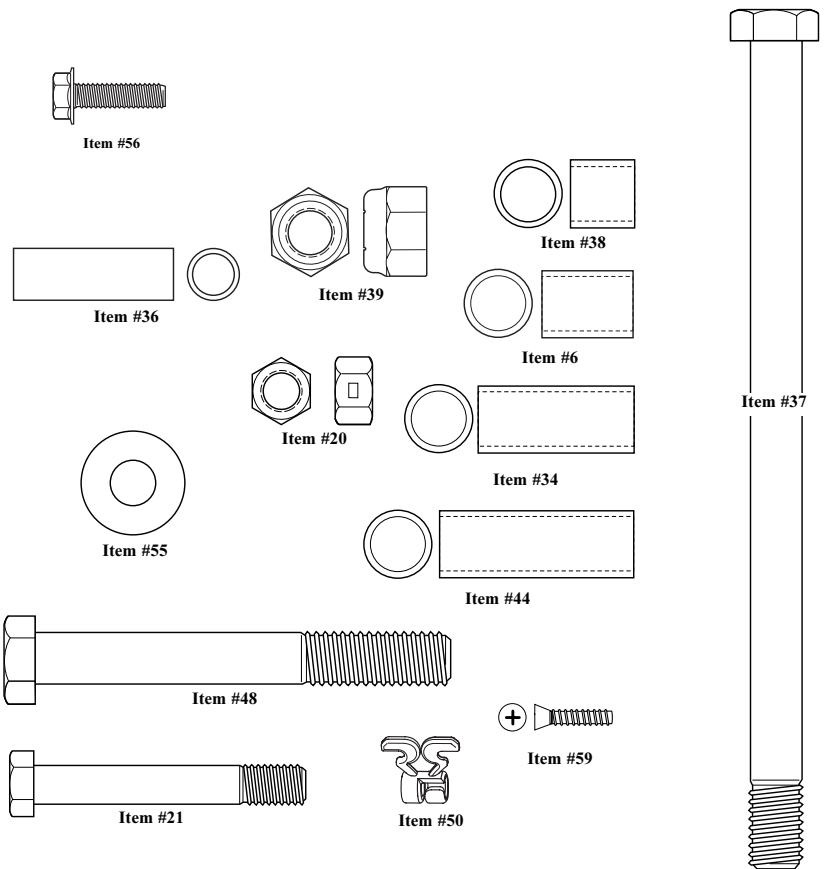

- 1.** Assemble backboard brackets (35) using spacers (36), bolts (21), and nuts (20) as shown.

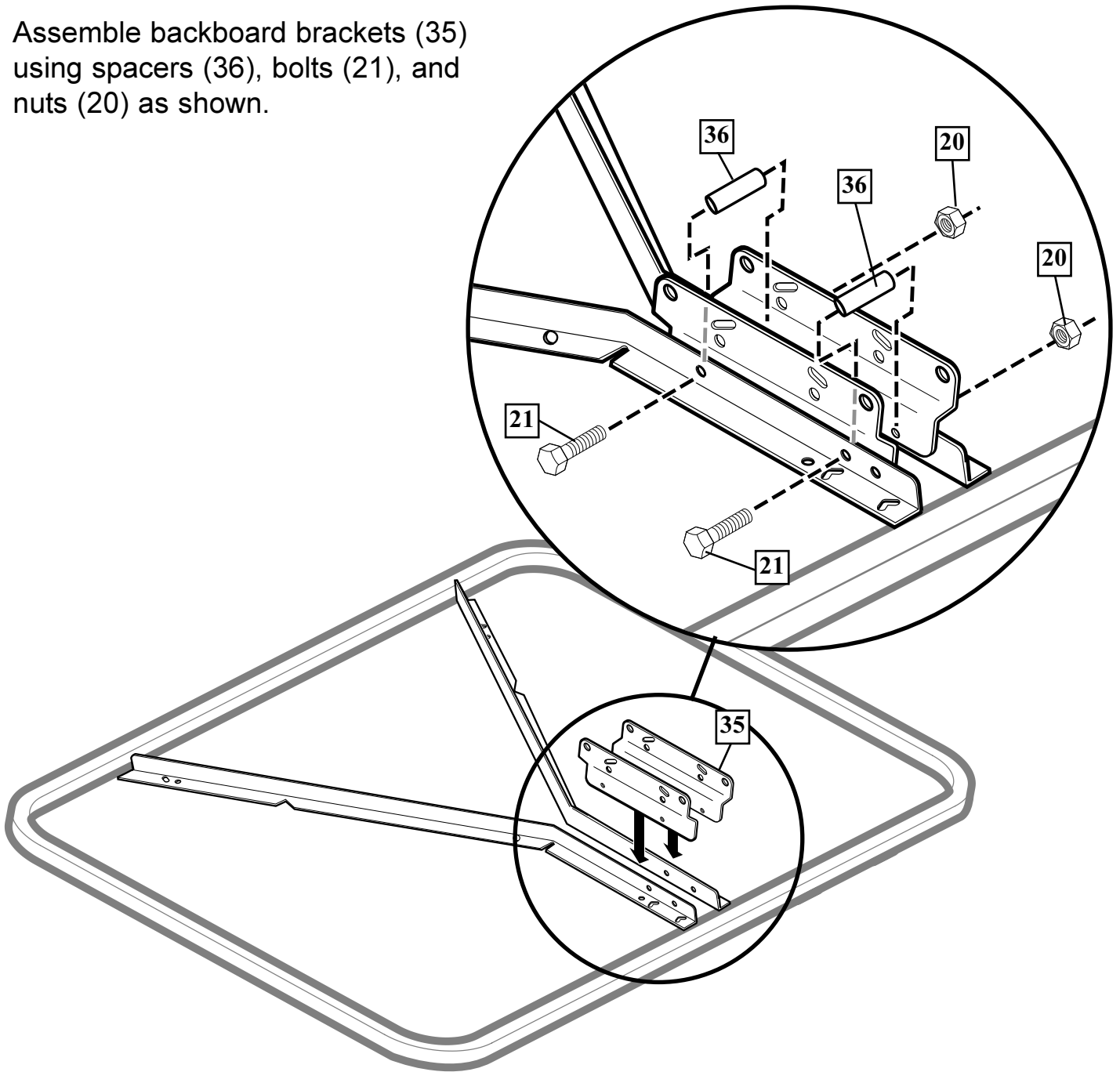

- 2.** Identify elevator tubes (43 & 40).

Toward Board

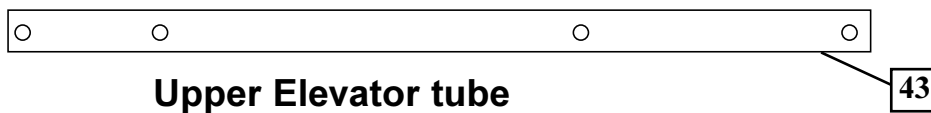

Toward Pole

Upper Elevator tube

Toward Board

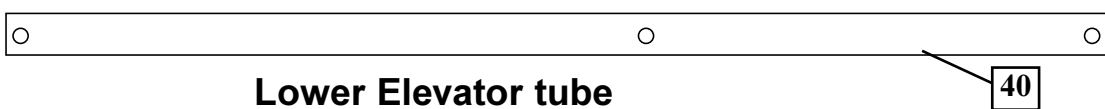

Toward Pole

Lower Elevator tube

- 3.** Attach lower elevator tubes (40) and counter balance spring (41) to backboard support brackets (35) using spacers (34), bolt (37), and nut (39) as shown. **NOTE:** Rim mounting nuts and bolts (56) supplied with rim hardware. **NOTE:** DO NOT use washers here on spring return style rims.

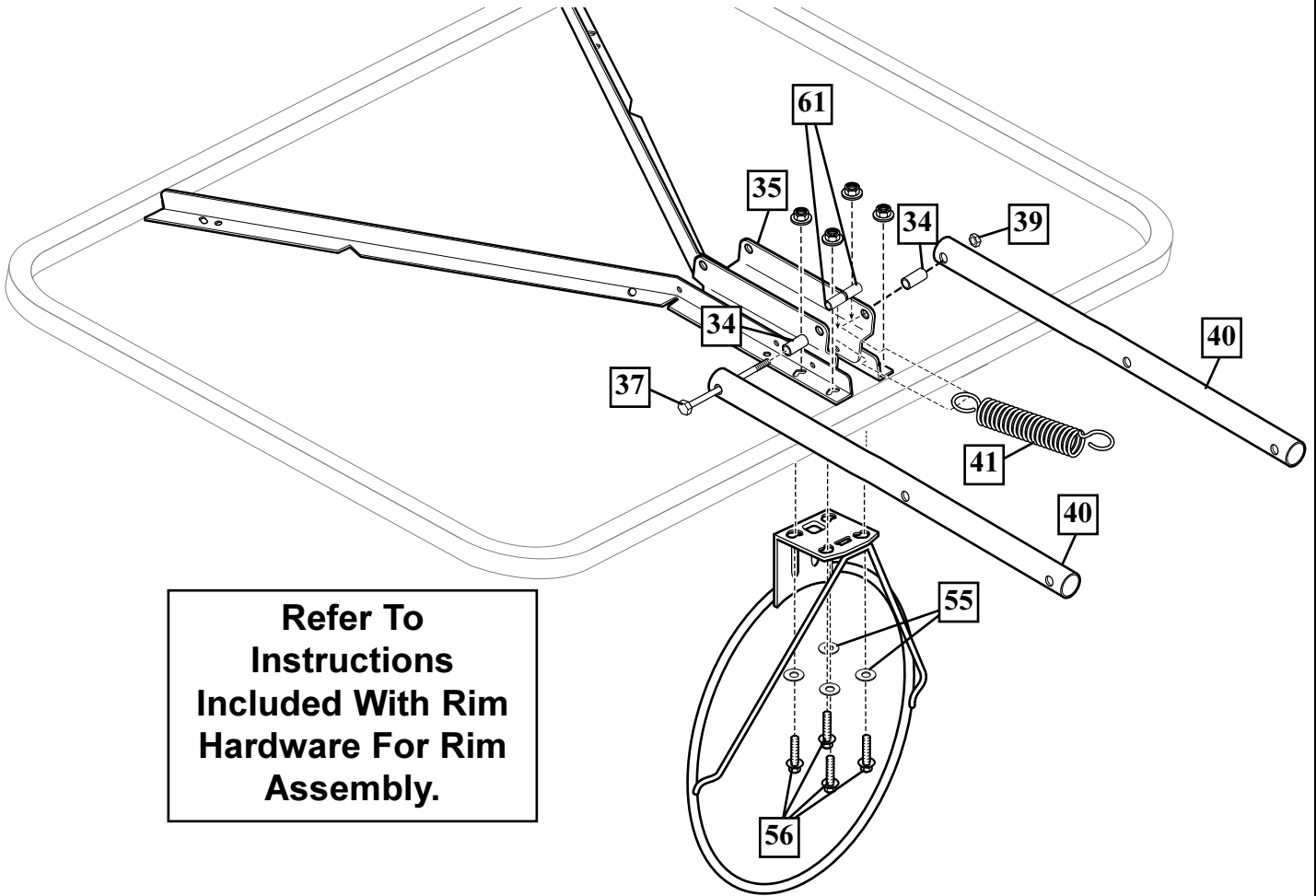

**Refer To  
Instructions  
Included With Rim  
Hardware For Rim  
Assembly.**

- 4.** Install cover (60) over spring return mechanism as shown.

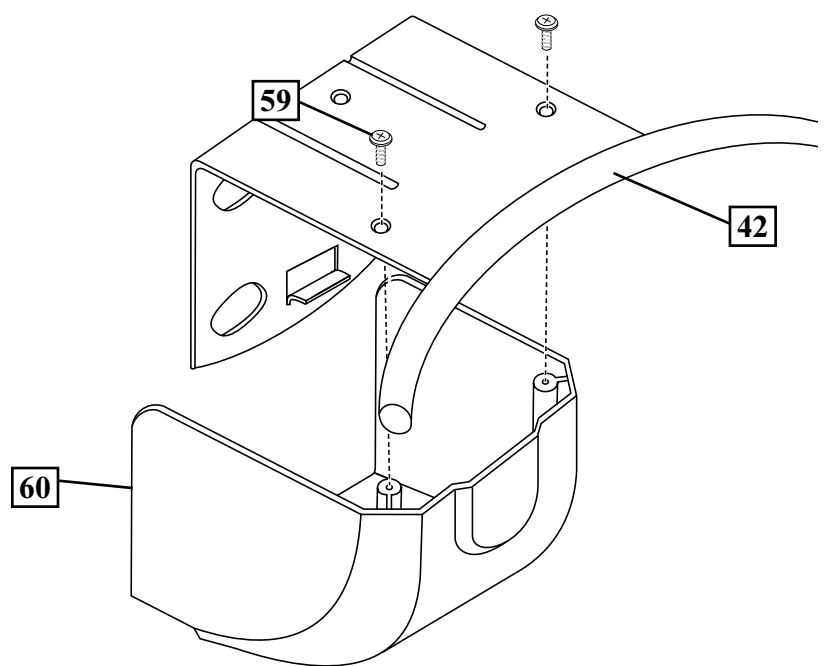

- 5.** Attach upper elevator tubes (43) to backboard support brackets (35) using spacers (34 & 61), bolt (58), and nut (39) as shown.

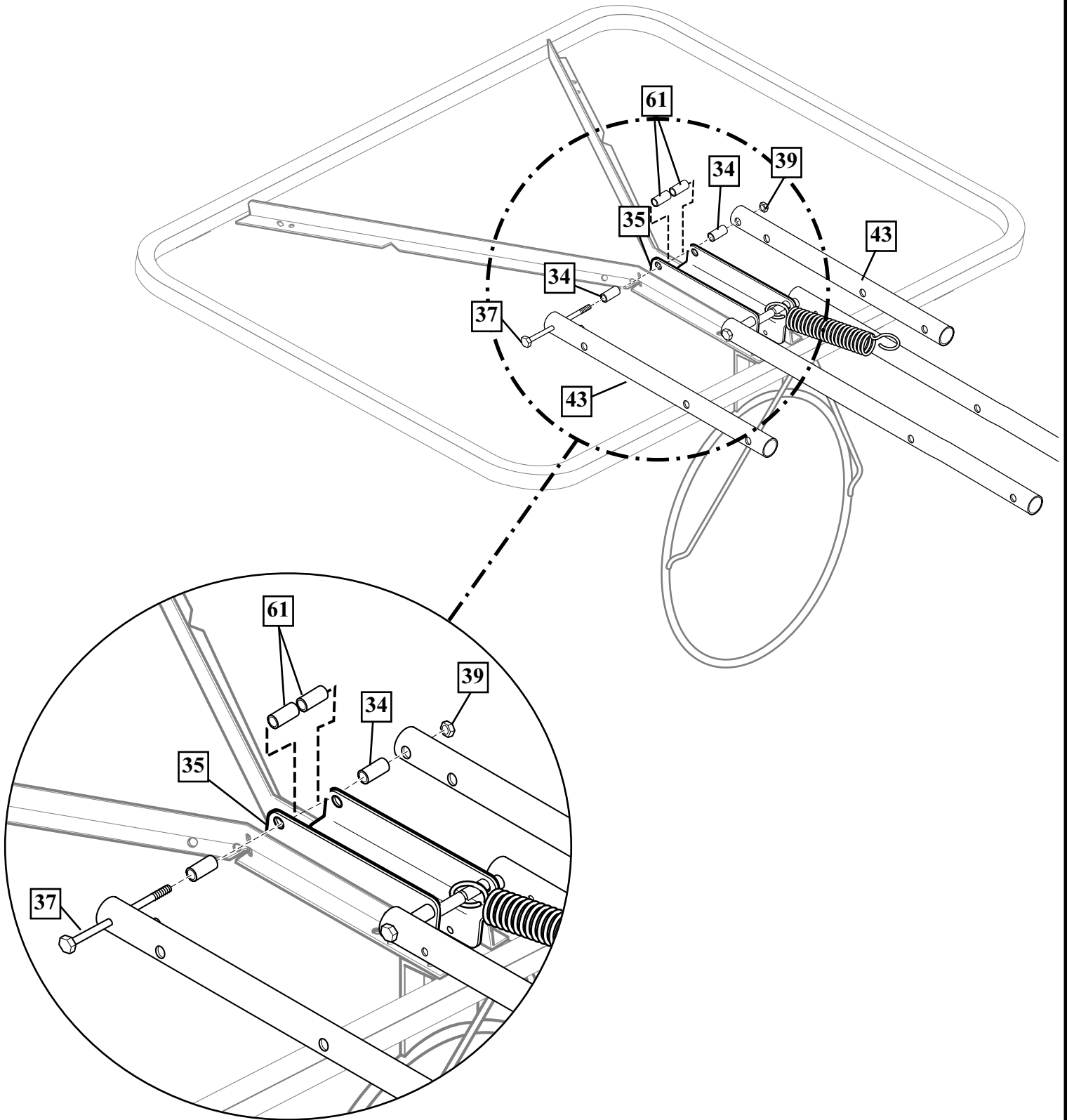

**6.** Install net clips.

**⚠ WARNING!**

USE OF THIS PRODUCT WITHOUT PROPER INSTALLATION OF SMART CLIPS®, OR WHEN ALL SMART CLIPS® ARE NOT PRESENT COULD RESULT IN BODILY HARM. BE SURE TO FOLLOW DIRECTIONS CAREFULLY.

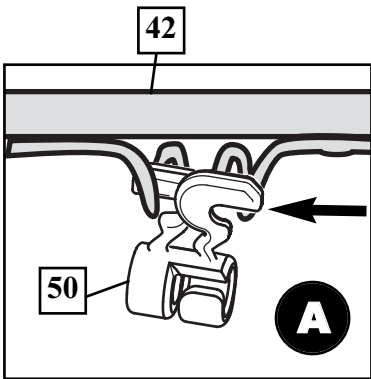
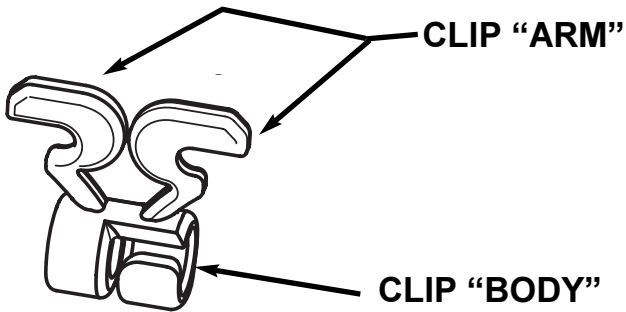

Insert one "arm" of clip into ram as shown. Twist "body" of clip slightly so that second "arm" slides over the top of the first "arm" as shown. Push in direction indicated by arrows.

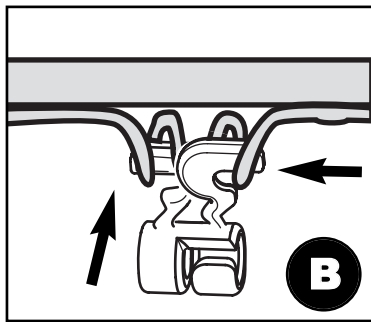

Push second "arm" back and into ram as shown.

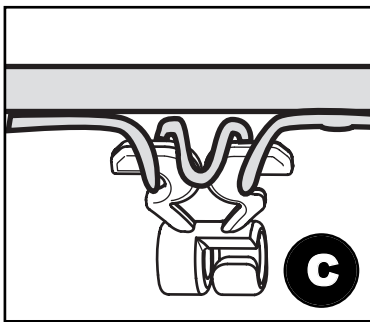

Twist "body" of clip slightly again to spread "arms" of clip. Clip "arms" must be flat and touching edge to edge as shown, not overlapping.

# NET INSTALLATION

7.

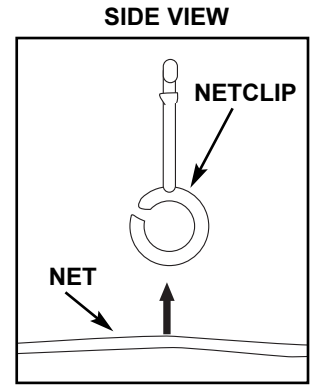
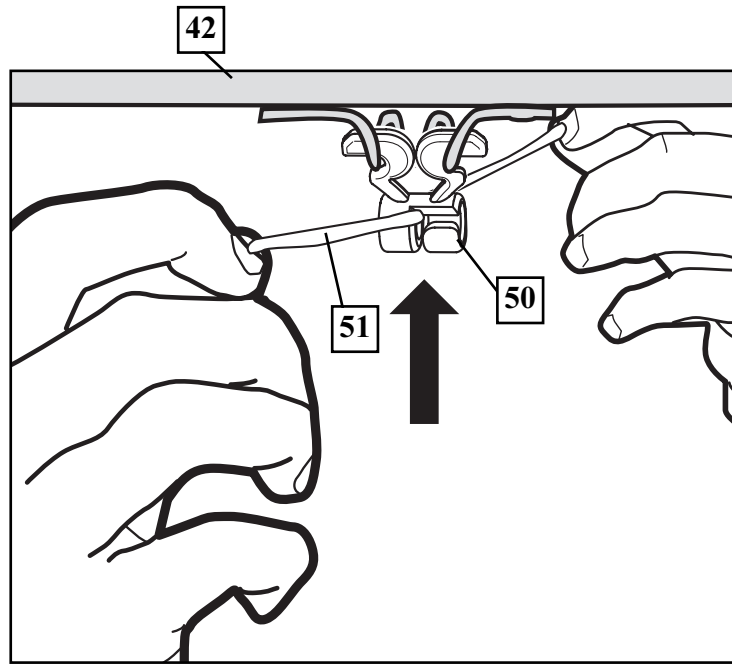

Insert net into bottom of clip as shown.

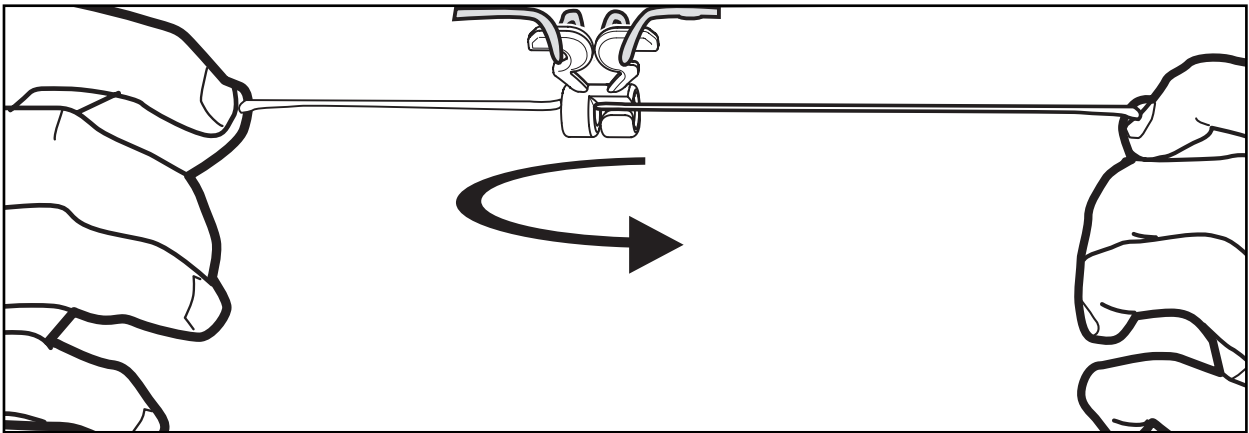

Twist net until it snaps into position.  
Net must be centered through clip.

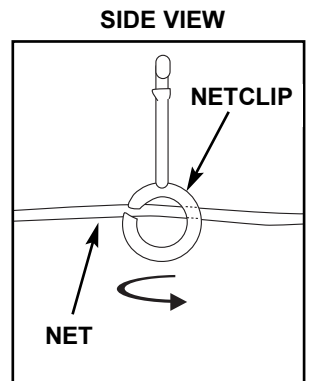

- 8.** Support pole on sawhorse. Attach backboard assembly to top pole section (4) as shown. Install pole cap (46). **NOTE:** Two people are recommended for this step. Use caution; elevator assembly is heavy.

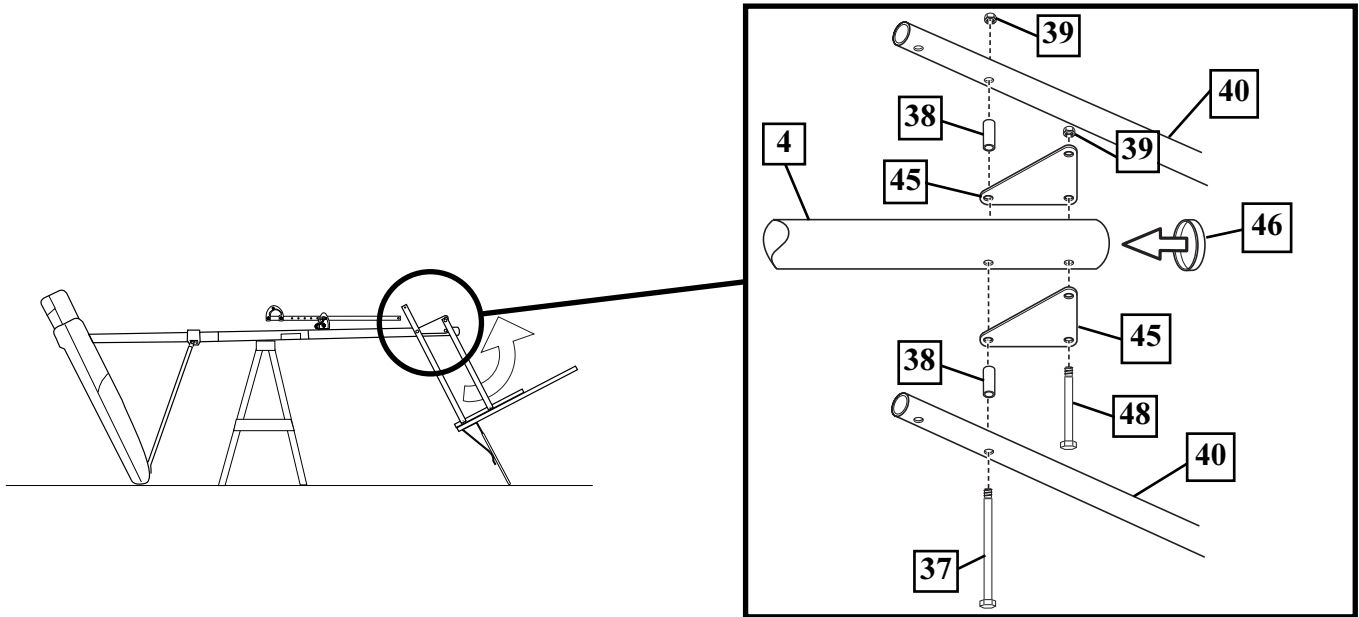

- 9.** Install upper elevator tubes (43) to triangle plates (45) as shown. Install handle assembly to lower elevator tubes (40) using bolt (37), spacers (44), and nut (39) as shown. **NOTE:** Before going on to next step, set adjustable system assembly to the 10' (3.05 m) setting.

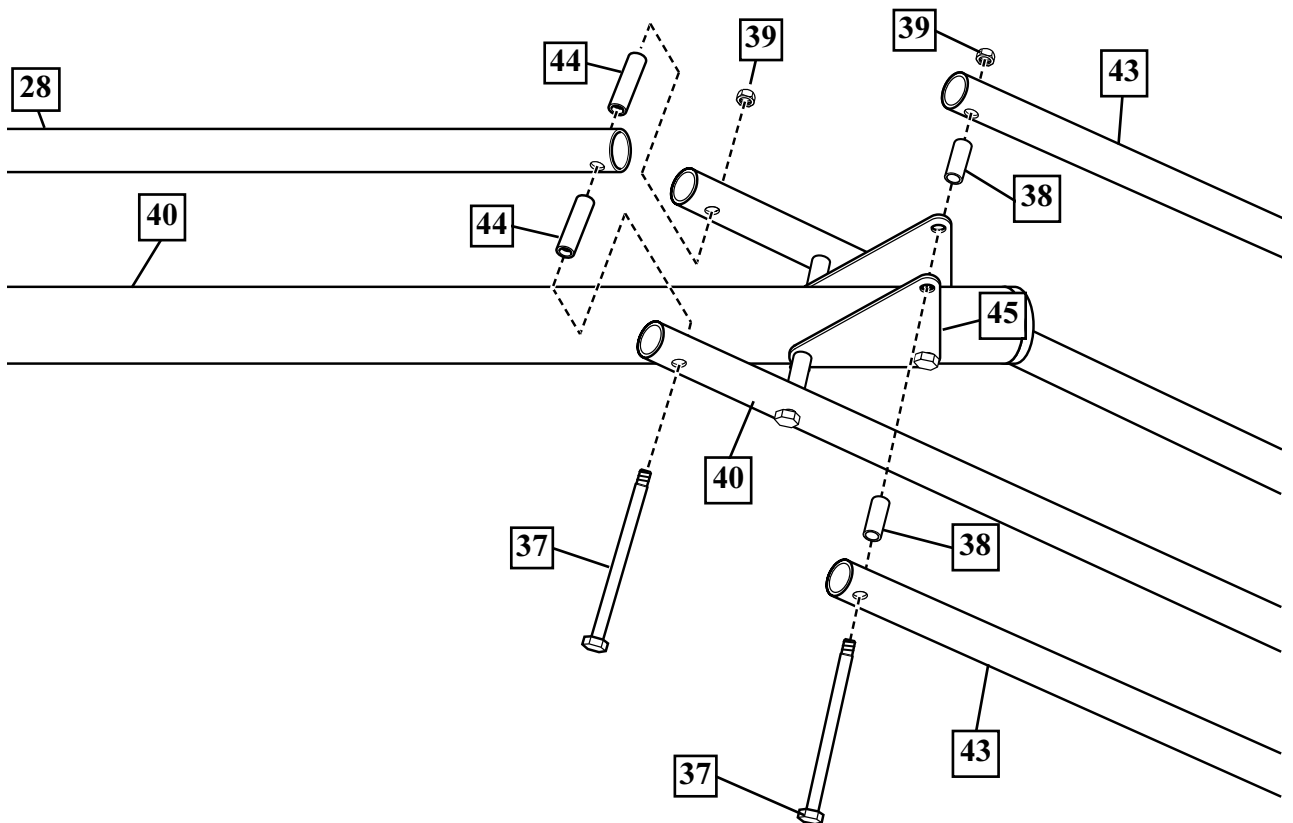



- 10.** Insert bolt (37) through left side of upper elevator tube (43), then stretch spring (41) onto bolt (37). Insert bolt (37) through right side of upper elevator tube (43) and secure with nut (39).

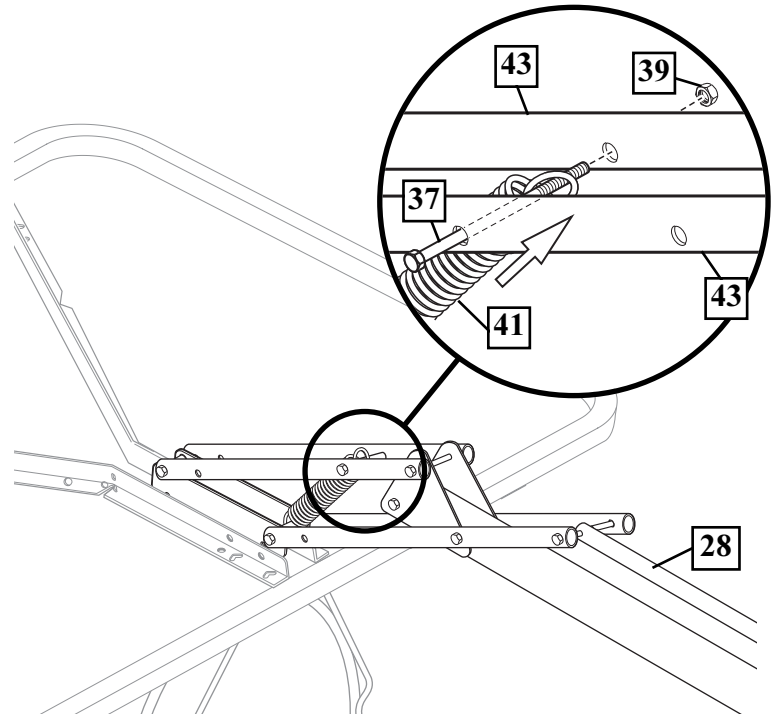

**⚠ WARNING!**

**USE EYE PROTECTION WHEN INSTALLING SPRINGS.**

- 11.** Roll completed assembly to desired position. Fill tank with water (approx. 34 gallons/129 Liters) or sand (approx. 280 lbs./128 kg) and snap cap (49) in place. Secure assembly to ground using rope (52) and tie down stake (53).

**⚠ CAUTION!**

**ADD TWO GALLONS (7.6 LITERS) OF NON-TOXIC ANTIFREEZE IN SUB-FREEZING CLIMATES.**

**⚠ WARNING!**

**DO NOT LEAVE ASSEMBLY UNATTENDED WHEN EMPTY; IT MAY TIP OVER.**

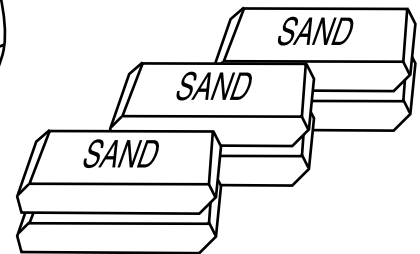
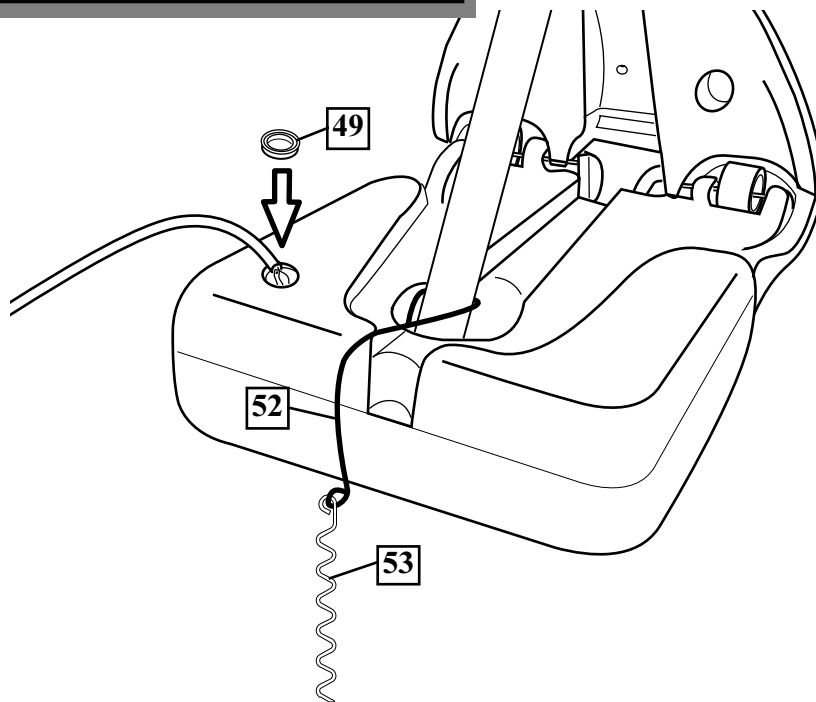

## SECTION C: APPLY HEIGHT AND MOVING LABEL & HEIGHT ADJUSTMENT

1. Apply height adjustment and moving label (54) to front of pole as shown.

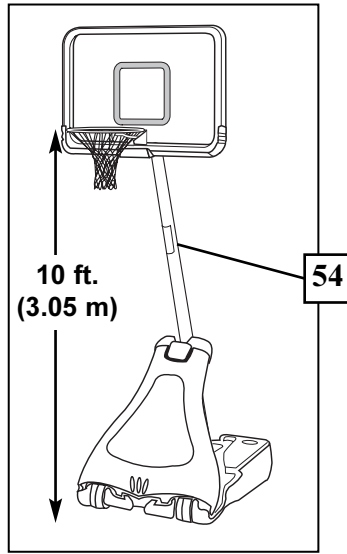

### ⚠ WARNING!

TWO PEOPLE  
REQUIRED FOR THIS  
PROCEDURE. FAILURE  
TO FOLLOW THIS  
WARNING COULD  
RESULT IN SERIOUS  
INJURY AND/OR  
PROPERTY DAMAGE.

### NOTE:

Peel protective film from  
surface of acrylic  
backboard prior to use.

2. A. While holding handle, remove pin (26).  
B. Move elevator up or down to desired height.  
C. Replace pin (26) full length to lock system at desired height.

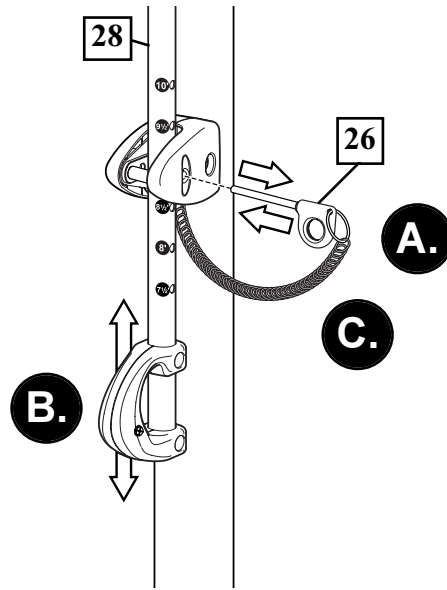

### ⚠ WARNING!

DO NOT ALLOW  
CHILDREN TO ADJUST  
HEIGHT.