



Affinity™

Owner's Manual



IMPORTANT SAFETY INSTRUCTIONS

READ AND FOLLOW ALL INSTRUCTIONS

SAVE THESE INSTRUCTIONS

WARNING: RISK OF ACCIDENTAL INJURY OR DROWNING; CHILDREN SHOULD NOT USE HYDROMASSAGE BATHTUB WITHOUT ADULT SUPERVISION.

WARNING : TO AVOID INJURY, EXERCISE CAUTION WHEN ENTERING OR EXITING THE HYDROMASSAGE BATHTUB

WARNING: RISK OF ACCIDENTAL INJURY OR DROWNING; DO NOT USE HYDROMASSAGE BATHTUB UNLESS ALL SUCTION GUARDS ARE INSTALLED TO PREVENT BODY AND HAIR ENTRAPMENT.

WARNING: KEEP BODY AND HAIR A MINIMUM OF 6" AWAY FROM SUCTION FITTING AT ALLTIMES WHEN THE WHIRLPOOL SYSTEM IS OPERATING. HAIR LONGER THAN SHOULDER LENGTH SHOULD BE SECURED CLOSE TO THE HEAD.

WARNING: NEVER DROP OR INSERT ANY OBJECT INTO ANY OPENING.

WARNING: RISK OF ELECTRICAL SHOCK; DO NOT PERMIT ELECTRICAL APPLIANCES (SUCH AS HAIR DRYER, LAMP, TELEPHONE, RADIO OR TELEVISION) WITHIN 60" (1.5 M) OF THIS HYDROMASSAGE BATHTUB.

WARNING: RISK OF ACCIDENTAL INJURY OR DROWNING; DO NOT USE DRUGS OR ALCOHOL BEFORE OR DURING THE USE OF HYDROMASSAGE BATHTUB EQUIPPED WITH A HEATER TO AVOID UNCONSCIOUSNESS AND POSSIBLE DROWNING.

WARNING: RISK OF FETAL INJURY; PREGNANT OR POSSIBLY PREGNANT WOMEN SHOULD CONSULT A PHYSICIAN BEFORE USING A HYDROMASSAGE BATHTUB EQUIPPED WITH A HEATER.

WARNING: RISK OF HYPERTHERMIA AND POSSIBLE DROWNING; DO NOT USE A HYDROMASSAGE BATHTUB EQUIPPED WITH A HEATER IMMEDIATELY FOLLOWING STRENUOUS EXERCISE.

CAUTION; TEST THE GROUND FAULT CIRCUIT INTERRUPTER PROTECTING THIS APPLIANCE PERIODICALLY IN ACCORDANCE WITH MANUFACTURER'S INSTRUCTIONS.

WARNING: RISK OF HYPERTHERMIA AND POSSIBLE DROWNING; WATER TEMPERATURE IN EXCESS OF 100°F (38° C) MAY BE INJURIOUS TO YOUR HEALTH. CHECK AND ADJUST WATER TEMPERATURE BEFORE USE.

WARNING: RISK OF HYPERTHERMIA; PEOPLE USING MEDICATIONS AND/OR HAVING AN ADVERSE MEDICAL HISTORY SHOULD CONSULT A PHYSICIAN BEFORE USING A HYRDOMASSAGE BATHTUB EQUIPPED WITH A HEATER.

AN EQUIPMENT GROUNDING TERMINAL IS PROVIDED IN THE FIELD WIRING COMPARTMENT. TO REDUCE THE RISK OF ELECTRICAL SHOCK, THIS TERMINAL MUST BE CONNECTED TO THE GROUNDING MEANS PROVIDED IN THE ELECTRICAL SUPPLY PANEL WITH A CONNECTOR EQUIVALENT IN SIZE TO THE CIRCUIT CONNECTORS SUPPLYING THIS EQUIPMENT.

PRECAUTIONS

Do not operate the whirlpool system unless the bath is filled with water to at least 2" above the highest jet.

Do not use oil-based bath additives in your whirlpool bath.

When cleaning your bath, do not use abrasive substances which will damage the bath's surface.

To prevent discoloration of the acrylic finish, do not fill the bath with water in excess of 140°F (60°C).

The whirlpool system should be purged at least twice a month. For your convenience, we have developed a plumbing system cleaner (Systems Clean™) specifically for whirlpool baths. For availability call 1-800-288-4002.

Use this unit only for its intended purpose as described in this manual. Do not use attachments not recommended by the manufacturer.

This unit must be connected only to a supply circuit that is protected by a ground fault circuit interrupter (GFCI). Such a GFCI should be provided by the installer and should be tested on a routine basis. To test the GFCI, push the test button. The GFCI should interrupt power. Push the reset button. Power should be restored. If the GFCI fails to operate in this manner, there is a ground current flowing, indicating a possibility of an electric shock. Do not use this unit. Disconnect the unit and have the problem corrected by a qualified electrician before using.

A pressure wire connector is provided on the exterior of the motor to permit connection of an No. 8 AWG (8.4 mm) solid copper bonding conductor between this unit and all other electric equipment and exposed metal in the vicinity, as needed to comply with local requirements.

This unit should be installed by a licensed electrician and grounded.

For built-in and drop-in units, install to permit access for servicing.

Note: This is a professional grade product. A knowledge of construction techniques, plumbing and electrical installation according to codes are required for proper installation and user satisfaction. We recommend that a licensed contractor perform the installation of all Jacuzzi Whirlpool Bath products. Our warranty does not cover improper installation related problems.

Contents

Specifications & Rough-in Reference _____	2
Framing and Support _____	3
Wall Cutout & CD/Radio Installation _____	4-5
TV Installation _____	6
Service Access _____	7
Electrical _____	7
Drain Information and Plumbing _____	7
Water Supply _____	7
Operation _____	8-11
Maintenance _____	12-13
Template _____	15
Warranty _____	17-18

Save These Instructions for Future Use.

Owner's Record

Date Purchased _____

Purchased From _____

Installed By _____

Serial Number _____

Specifications & Rough-in Reference

DIMENSIONS

68" (1727 mm) L
 68" (1727 mm) W
 22" (559 mm) H1
 27" (686 mm) H2
 35-7/8" (911 mm) H3

DRAIN/OVERFLOW DIMENSIONS

19" (483 mm) A
 12" (305 mm) B

TOTAL WEIGHT/FLOOR LOADING

1500 lb
 (682 kg)/
 47 lb/sq. ft.
 (229 kg/sq. m)

OPERATING GALLONAGE

120 U.S. gal
 (455 liters)

PRODUCT WEIGHT

250 lb
 (114 kg)

ELECTRICAL REQUIREMENTS

BATH

115 VAC 60 Hz.
 30 Amp
 Single Phase
 (Must be Class A GFCI Protected)
 The unit must be hard wired (permanent) from this circuit to the control box.

ELECTRICAL REQUIREMENTS RAPIDHEAT™ HEATER

115 VAC 60 Hz.
 15 Amp
 Single Phase
 (Must be Class A GFCI Protected)
 The unit must be hard wired (permanent) from this circuit to the control box.

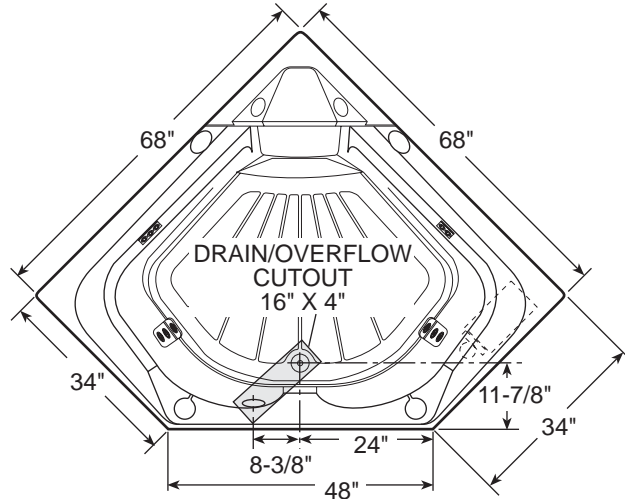

TOP VIEW

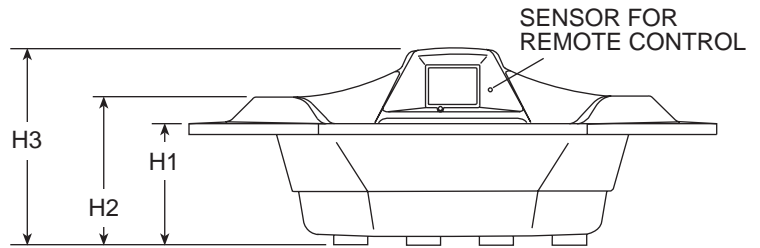

FRONT VIEW

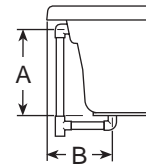

DRAIN/OVERFLOW

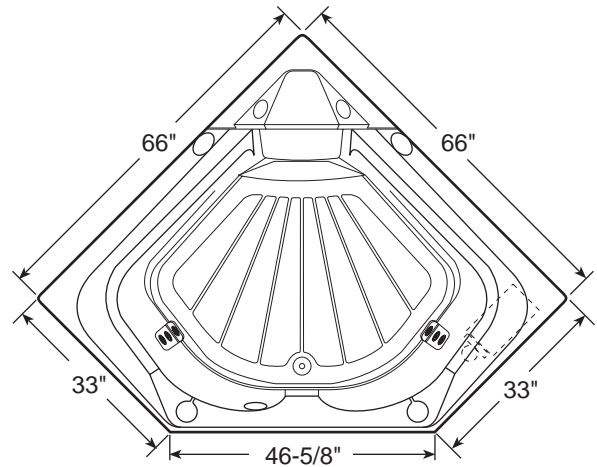

CUTOUT

Important: Read complete instructions before beginning installation.

Each whirlpool bath arrives ready for installation, completely equipped with motor/pump assembly and plumbing and fittings necessary for whirlpool operation. An optional drain/overflow kit is available for installation on the bath.

Remove the bath from the carton. Retain the shipping carton until satisfactory inspection of the product has been made. **Do not lift the bath by the plumbing at any time; handle by the shell only.**

Immediately upon receipt, inspect the shell before installing. Should inspection reveal any damage or defect in the finish, do not install the bath. Damage or defect to the finish claimed after the bath is installed is excluded from the warranty. Jacuzzi Whirlpool Bath's responsibility for shipping damage ceases upon delivery of the products in good order to the carrier. Refer any claims for damage to the carrier. For definitions of warranty coverage and limitations, refer to the published warranty information packed with the product.

All bath units are factory tested for proper operation and watertight connections prior to shipping. **Note: Prior to installation, the bath must be filled with water and operated to check for leaks that may have resulted from shipping damage or mishandling.** Jacuzzi Whirlpool Bath is not responsible for any defect that could have been discovered, repaired, or avoided by following this inspection and testing procedure.

Framing and Support

The drain/overflow of the bath extends below the bottom of the bath. Note that this requires a cutout in the floor.

The floor structure beneath the bath must be able to support a total weight of bath, water, and bather. Refer to the table under total weight for your model. The unit must be supported from the bottom of the bath and **not** from the bath rim or tile flange. If the subfloor is level, no other preparation is necessary. You can proceed to install the bath. If the subfloor is not level, you **MUST** level the entire surface prior to installing the bath. The use of materials that shim or provide a level installation are allowed provided the method used will insure a level bath that is supported from the bottom. Materials that may be used are a floor leveling compound, mortar, plaster or minimal expansion structural foam having a density of a minimum of 5 lbs./cubic ft; however the bath must remain level in order for it to drain properly and the foam feet must make full contact with the leveling material. Both sides of a joint or splice of subfloor should be level to each other.

The rim of the bath is not designed to support weight. If finish material is to overlap (maximum 1" overlap) or contact the bath, the added weight must be fully self-supporting.

The protective film liner inside the bath should be left there to prevent damage to the finish from shoes, tools, etc. during installation and should not be removed until final cleanup.

Typical Installation

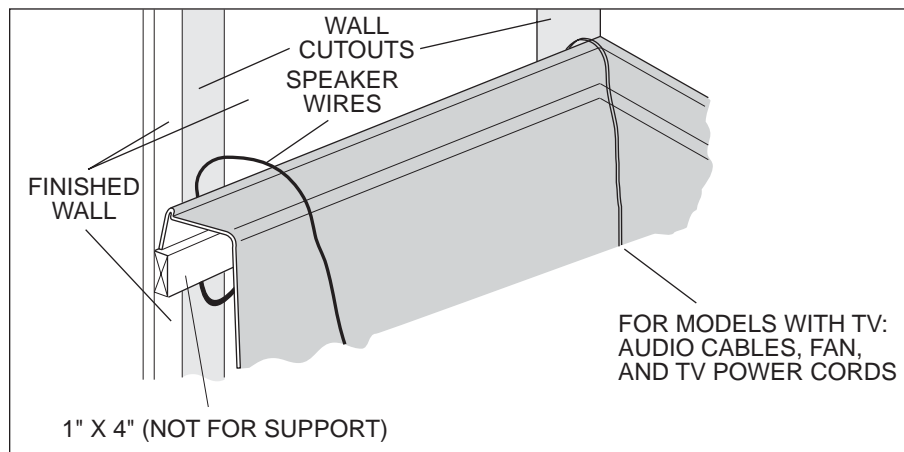

Wall Cutout and CD/Radio Installation

The installation requires a cutout in the wall. The cutout allows room for the speakers, CD/Radio speaker/power & TV audio cable wires.

NOTE: CD/Radio must be located a **minimum of 5'** away from the interior of the bath. The cable provided with the unit is designed for this minimum distance. If a longer distance is desired, cut the cable and splice to the power cord with leads provided with the CD/radio. Do not exceed 20' as the CD/radio audio performance will be reduced and damage to the unit can occur.

Before final setting of the bath, locate the CD/radio speaker & power harness, TV audio cable and CD/Radio grounding wire (CD/Radio chassis to control box bonding bar) coiled under the bath rim. Run wires through wall cutout to CD/Radio build out.

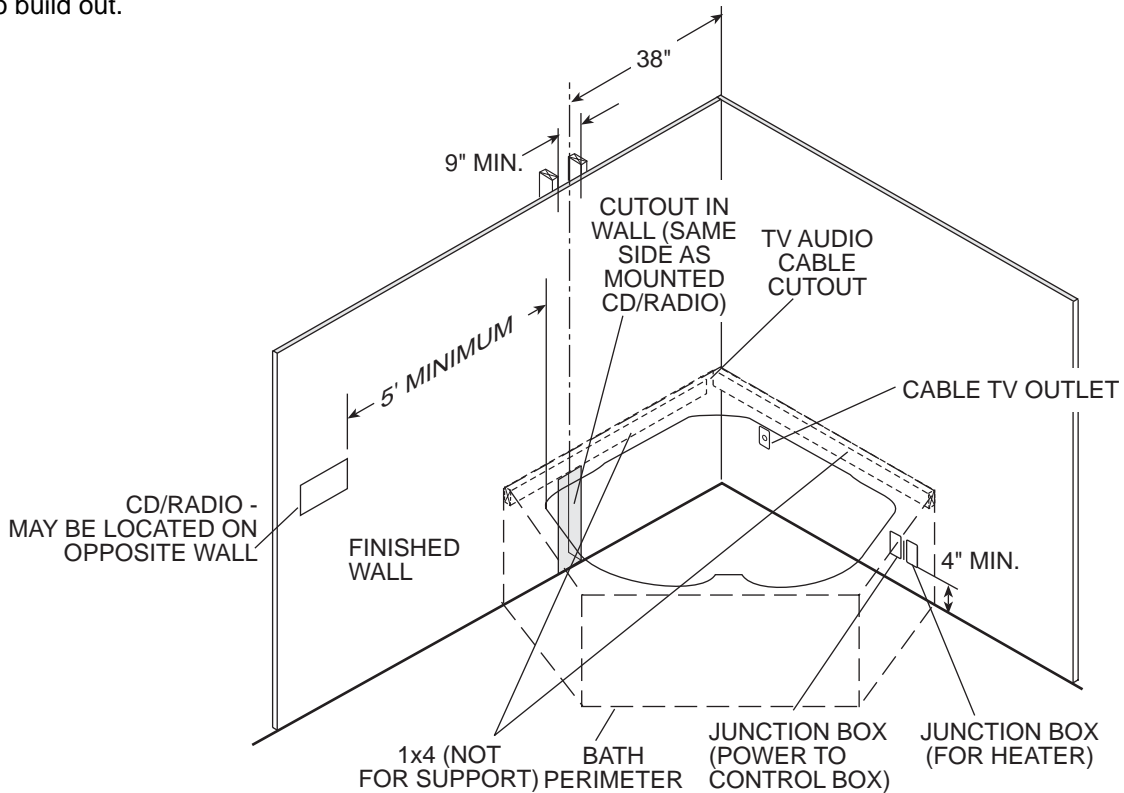

To allow clearance for the CD/Radio, build-out section of wall 7-1/2" from back of stud as shown. We recommend using 1/2" plywood. A template is provided for sleeve mounting hole on page 13. Keep CD/Radio build-out away from insulating materials.

NOTE: CD/Radio has been mechanically fastened to the bottom of the TV shelf. Remove before installing unit.

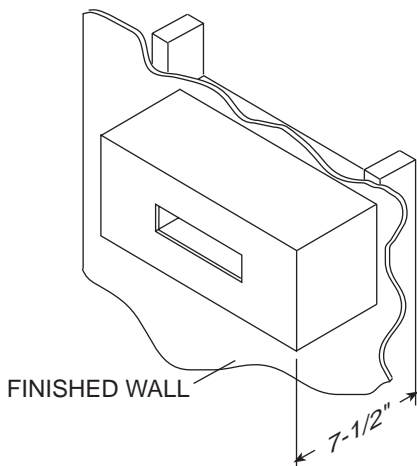

Before mounting, press control panel release button and detach control panel

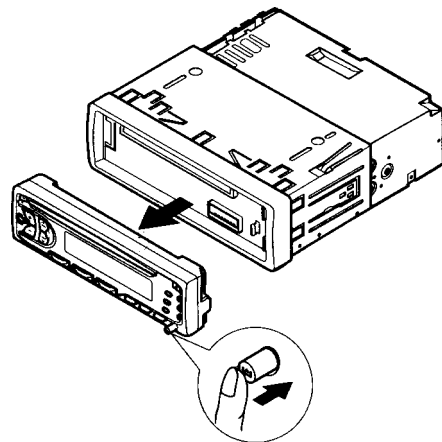

Remove trim plate.

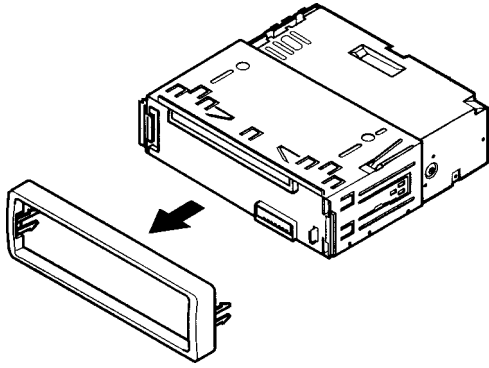

Remove sleeve after disengaging sleeve locks. Stand the unit and insert the 2 handles between the unit and sleeve to disengage the sleeve locks. When standing the unit be careful not to damage the fuse on the rear. Remove the sleeve. Retain the handles for future use.

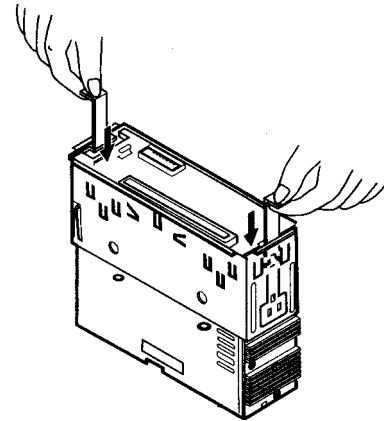

Run wires through sleeve. Insert sleeve into build out. When flush, bend appropriate tabs to hold sleeve firmly in place. Connect the speaker & power connector and TV audio to the CD/radio. Connect the green ground wire to the CD /radio chassis ground.

Slide Unit into sleeve until locked. Attach trim plate and control panel.

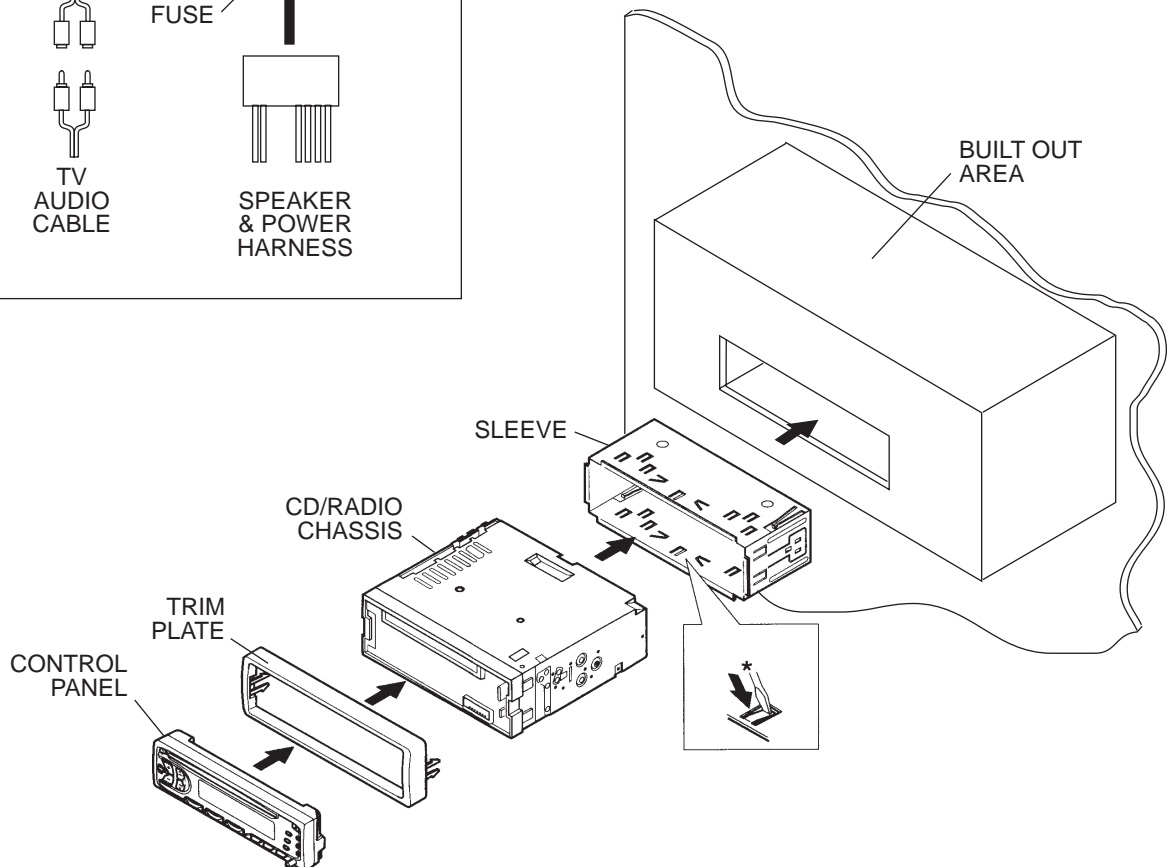
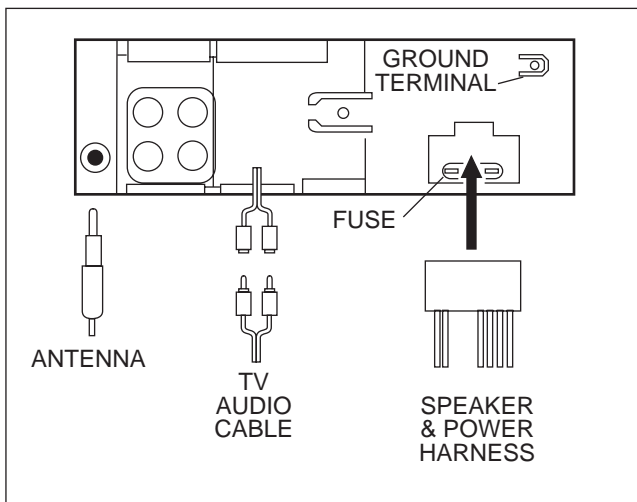

TV Installation

Remove back cover by lifting straight upward and then remove the drip shield. Tighten cable tie and cut off excess. Tighten cable tie with anchor (not supplied) to the TV power cord. It is not necessary to attach anchor to drip shield; the cable tie and anchor are used to ensure the TV power cord remains in the TV housing. Locate blackout panel and peel protective backing off adhesive. Position blackout panel onto TV screen and press adhesive to TV. Position TV on shelf and hook up power cord, audio and cable TV cables. Slide TV flush to front window. Make sure the sensor hole on the blackout panel aligns with the TV sensor. If they do not align, adjust the shelf with positioning feet till they are aligned. Reinstall drip shield. Connect speaker wires to back cover speakers observing polarity: right speaker purple + and purple w/black stripe -; left speaker green + and green w/black stripe -. Then position back cover by sliding downward over gasket seal. Make sure gasket seal did not detach from bath shell (extra gasket material has been provided). Secure with screws (an offset screwdriver is provided). An internal fan is provided to cool and ventilate the TV compartment. The fan will turn on in some instances depending on the thermostat within the TV compartment.

DRIP SHIELD WIRING

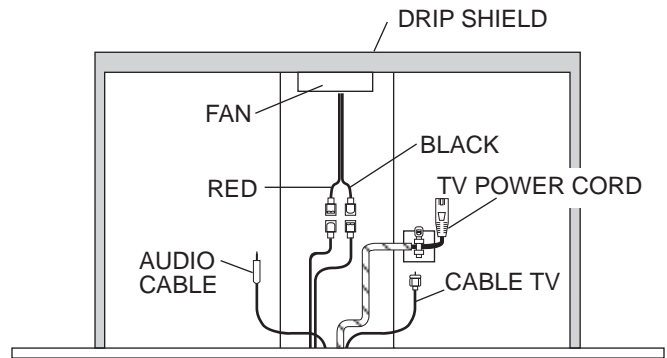

TV CONNECTIONS

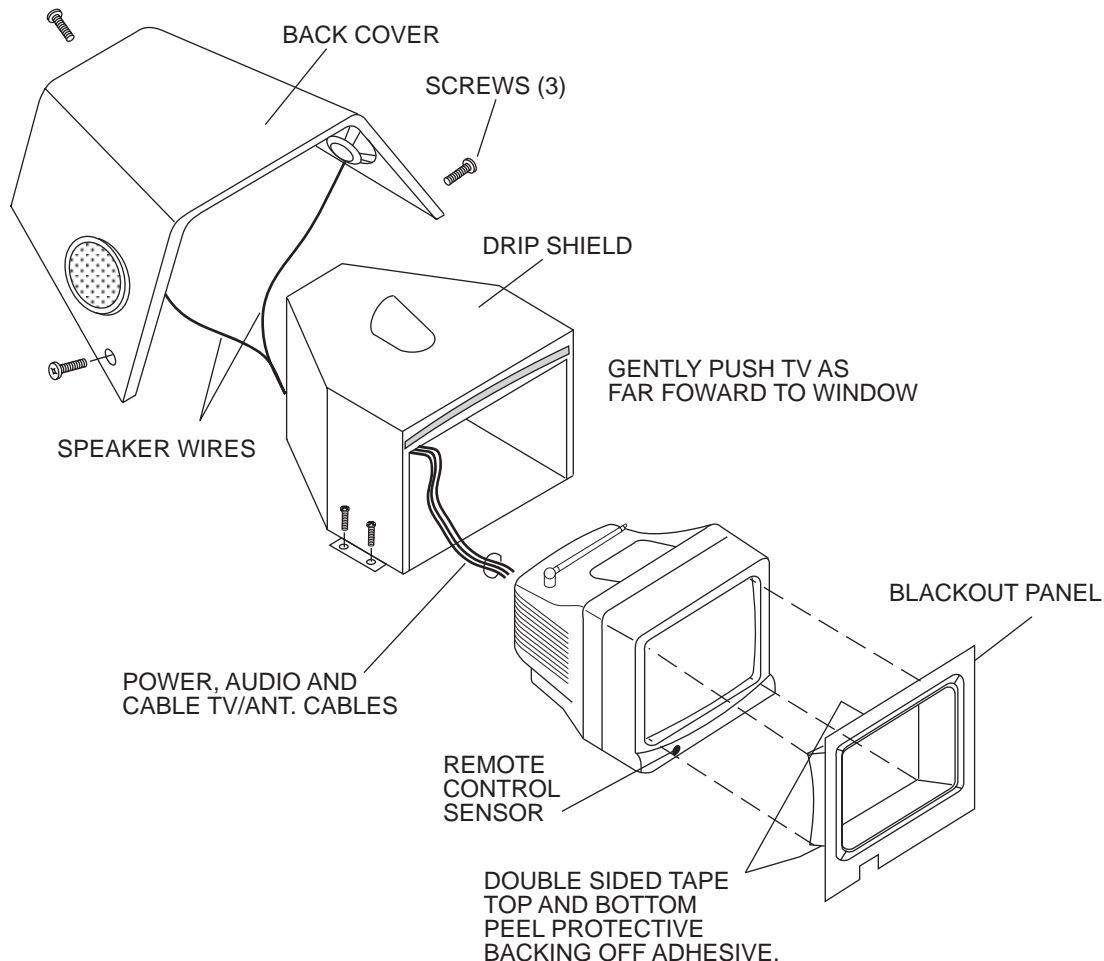
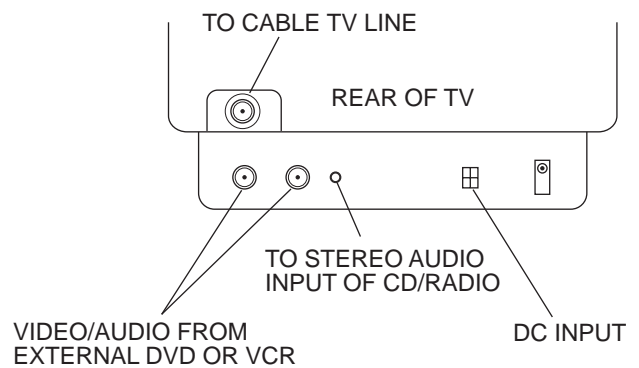

Service Access

For partially or fully sunken installations, allow for access to service connections. It is the installer's responsibility to provide sufficient service access. See Service Access illustration. Provide adequate ventilation (minimum 30 square inch opening) for cooling the motor and to supply sufficient air for the jets.

SERVICE ACCESS

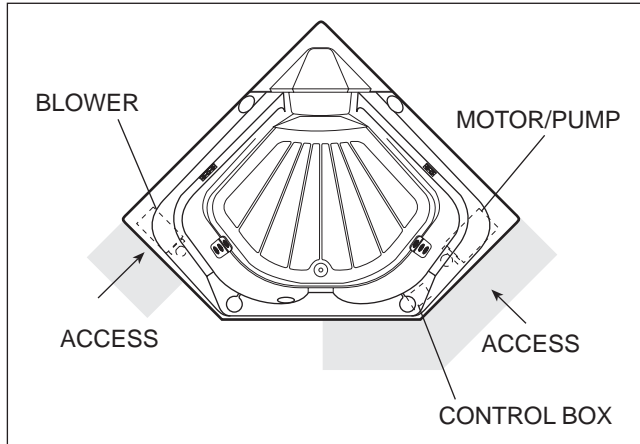

Electrical Connections

Two separate circuits are required for this unit:

Bath

Install a 115 VAC 30 AMP dedicated circuit protected by a Ground Fault Circuit Interrupter (GFCI). The unit must be hard wired (permanent) from this circuit to the control box. Remove cover of control box and hard wire from GFCI circuit to terminal block.

DANGER: RISK OF ELECTRIC SHOCK. Connect only to a circuit protected by a Ground Fault Circuit Interrupter.

Rapid Heat

Install a 120 VAC 15 AMP dedicated circuit with GFCI protection. The unit must be hard wired (permanent) from this circuit to the junction box for the heater (see below). For operation, refer to the RapidHeat instructions.

DANGER: RISK OF ELECTRIC SHOCK. Connect only to a circuit protected by a Ground Fault Circuit Interrupter.

We recommend that a qualified electrician perform this work.

CAUTION: Operating the motor/pump without enough water in the bath can cause leaking and permanent damage to the pump. Before power is applied to the installation, make sure the switch is in the OFF position to avoid pump damage.

Bonding

Connect a #8 gauge (10mm²) minimum solid copper bond wire from the house electrical panel or an approved local ground to all metal components (i.e. junction box etc.). An approved ground may be an 8 foot long ground rod (3 meter long earth rod), a plate electrode or other acceptable bond location. Check your local building code for requirements.

ELECTRICAL CONNECTIONS

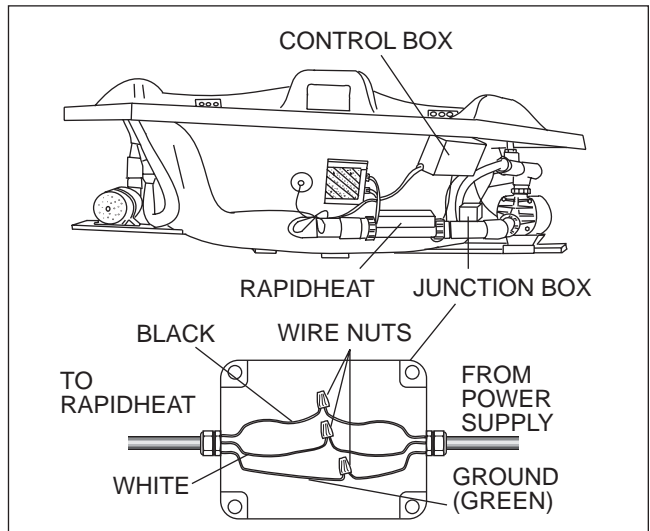

ELECTRICAL CONNECTION RAPIDHEAT

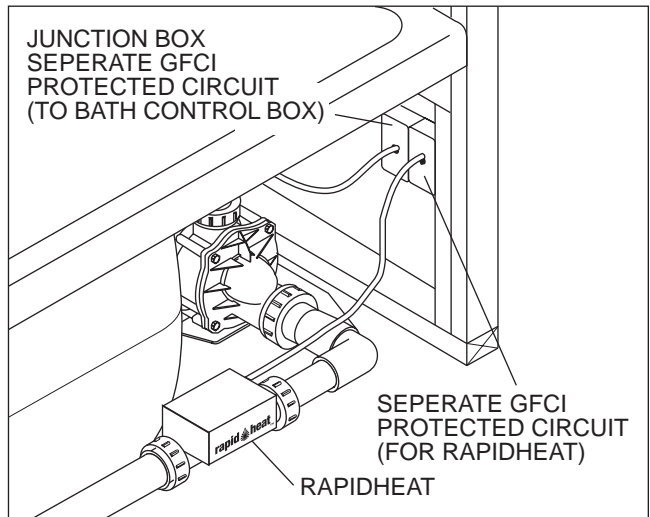

Drain Information

A drain/overflow assembly must be installed on the bath, water tested, and connected to the sanitary system of the house. After opening the carton, inspect for damage and verify that the kit is of the proper finish. In the Jacuzzi Whirlpool Bath drain/overflow kit, note that the waste flange, strainer, overflow cover and cover screws are packaged in a separate package within the kit to protect the trim finish. Follow the installation instructions provided with the drain/overflow kit.

After the drain is fully installed, test for proper drainage. If the unit does not drain properly, rectify this condition before proceeding with the installation. Jacuzzi Whirlpool bath is not responsible for removal and/or reinstallation costs.

NOTE: Watertight installation of the drain is the installer's responsibility. Drain leakage is excluded from the Jacuzzi Whirlpool Bath warranty of this product.

Plumbing

Pump, jets, and suction fittings for the whirlpool system are factory plumbed in schedule 40 PVC piping. All Jacuzzi Whirlpool Bath products are factory tested for proper operation and watertight connections prior to shipping.

Before securing the bath to the floor a test for possible water leaks must be made. Fill the bath and check for leaks. If leaks are detected, notify your Jacuzzi Whirlpool Bath Dealer. Do not install the unit.

Water Supply

Consult local authorities for plumbing code requirements in your area.

IMPORTANT: Proper installation of the fill spout plumbing and compliance with local codes are the responsibility of the installer. Jacuzzi Whirlpool Bath does not warrant connections of water supply fittings and piping, fill systems, or drain/overflow systems. Nor is it responsible for damage to the bath which occurs during installation.

CAUTION: A nonflammable protective barrier must be placed between soldering work and bath unit to prevent damage to the bath.

Clean-Up After Installation

To avoid dulling and scratching the surface of the bath, never use abrasive cleaners. A mild liquid detergent and warm water will clean soiled surfaces.

Remove spilled plaster with a wood or plastic edge. Metal tools will scratch the surface. Spots left by plaster or grout can be removed if lightly rubbed with detergent on a damp cloth or sponge.

Paint, tar, or other difficult stains can be removed with paint thinner, turpentine, or isopropyl alcohol (rubbing alcohol).

Minor scratches which do not penetrate the color finish can be removed by lightly sanding with 600-grit wet/dry sandpaper. You can restore the glossy finish to the acrylic surface of the bath with a special compound, Meguiar's #10 Mirror Glaze. If that is not available, use automotive rubbing compound followed by an application of automotive paste wax.

Major scratches and gouges which penetrate the acrylic surface will require refinishing. Ask your Jacuzzi Whirlpool Bath dealer for special instructions.

OPERATION

Water Level

Close the drain and fill the bath until water is at least 2" above the highest jet (see water line indicated in the illustration). **Do not turn on the whirlpool system at any time if the jets are not completely immersed in water.** Running the whirlpool system when there is insufficient water in the bath could result in water spraying outside the bath area. Running the whirlpool system without water will damage the recirculating pump.

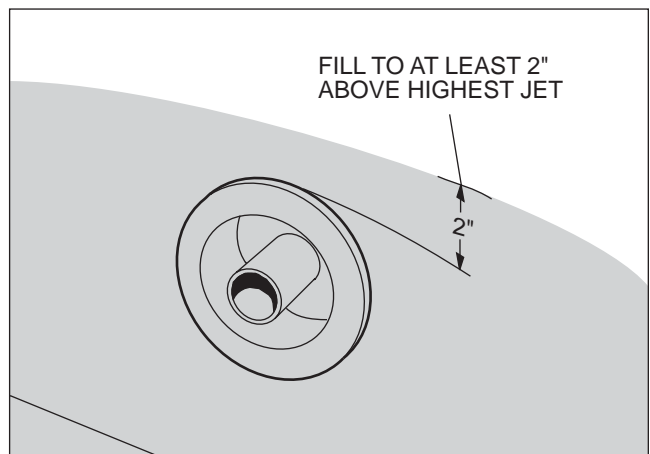

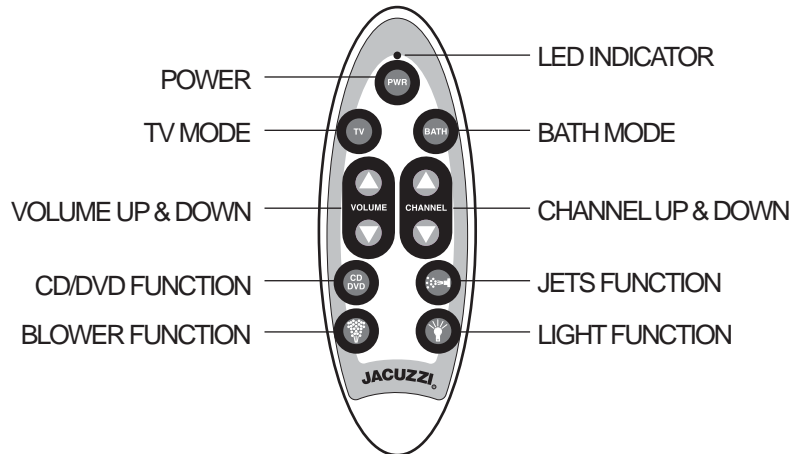

Remote Control





The Floating Remote Control is a universal remote control that has been programmed to operate the TV. If the remote has been deprogrammed the following procedure will reprogram the remote:





For TV

1. Press and release the TV button.
2. Press and hold the BLOWER  button. The LED will flash.
3. While holding the BLOWER  button, press the POWER button for 2 seconds until the LED lights up. Then release both buttons.
4. Enter the 5 digit code 12343 using the VOLUME up and down and CHANNEL up and down: Volume up = 1, Volume down = 2, Channel up = 3 and Channel down = 4.
5. The LED will shut off if the code is accurate and the setting successful. If not, the LED will flash twice and the procedure must be repeated starting from step 1.

For Bath

1. Press and release the Bath button.
2. Press and hold the BLOWER  button. The LED will flash.
3. While holding the BLOWER  button, press the POWER button for 2 seconds until the LED lights up. Then release both buttons.
4. Enter the 5 digit code 24332 using the VOLUME up and down and CHANNEL up and down: Volume up = 1, Volume down = 2, Channel up = 3 and Channel down = 4.
5. The LED will shut off if the code is accurate and the setting successful. If not, the LED will flash twice and the procedure must be repeated starting from step 1.

ACTIVATING THE WHIRLPOOL BATH (aim remote at sensor on bath)

1. Pressing the BATH button allows access to the JETS , LIGHT  BLOWER  functions.
 2. Press the LIGHT button once to activate the lights; press again to deactivate.
 3. Press the JETS button once to activate the jets; press again to deactivate.
 4. Press the BLOWER  button once to activate the blower; press again to deactivate.
- NOTE: Jets, light and blower will automatically turn off after 30 minutes.

PURGES

Automatic Purge

With all functions off either, manually or by program, a 60 minute timer will be initiated. Once this timer is finished, a 1 minute purge will be activated (blower) to purge any remaining water in the air channel. If any key is pressed the purge timer will be reset.

Daily Purge

If the user holds the button on the bath control on the unit for 5 seconds, the program will initiate a 1 minute purge (start the blower) and will purge every day at the same time for 1 minute. To cancel the daily purge option simply hold the button for 5 seconds. The daily purge will not activate if one of the accessories is on, but it will have priority on the Automatic purge. This means that if the program is waiting to Automatic purge and a Daily purge crosses that time, then the automatic purge will be cancelled and the daily purge will be initiated.

BATH CONTROL



CD/DVD FUNCTION (VIDEO INPUTS TO TV)

1. Press TV button, then POWER Button. This will turn the TV ON.
2. Press CD/DVD to select the applicable input source. The on-screen display will show VIDEO 1 or VIDEO 2 for any external video components or TV mode.

CD PLAYER/AM/FM SYSTEM

Power On

The CD player and AM/FM system must be activated from the manufacturers remote control for the CD unit or manually from the CD player panel. The floating remote does not control CD/AM/FM functions.

AUX-IN Setup

In order to hear the TV audio, CD Player/AM/FM System must be set to AUX-In mode. To perform this setting, follow the instructions of the CD Receiver manual under AUX IN Mode. If power to the unit is interrupted, the CD Receiver will have to be reset.

For complete operation of the CD/AM/FM unit consult the manual enclosed.

Note: The manufacturers remote for the CD/AM/FM unit is not intended to be used in the bath.

Note: The quality of AM reception will vary by locality. Jacuzzi Whirlpool Bath is not responsible for the quality of AM reception.

TV

The Floating Remote will control the volume and change the channels of the TV.

For complete operation of the TV consult the manual enclosed.

Note: The TV manufacturer's remote is not intended to be used in the bath.

REMOTE BATTERY REPLACEMENT

The remote is powered by 2 AAA size batteries. To change the batteries, unscrew and remove the rear cover. Remove the old batteries and load the new ones with their polarities (+ and -) aligned properly. Replace the cover making sure the water proof gasket (screws and control) is in the proper position.

After the batteries have been replaced, the LED will flash twice to indicate that the programmed codes are still memorized. The LED will flash 3 times to indicate the programmed codes have been erased and will have to be reprogrammed. You have 3 minutes to change the batteries before the codes will be erased.

NOTE: Batteries installed with incorrect polarity may leak and damage the remote control. Do not mix old and new batteries or carbon types with alkaline types.

BATTERIES (2 AAA)

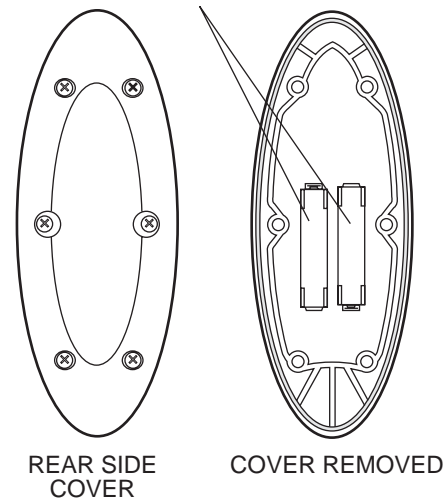

SUGGESTED LOCATION FOR REMOTE HOLDER

Apply a dab of clear silicone adhesive to the underside of holder and attach where convenient in area shown.

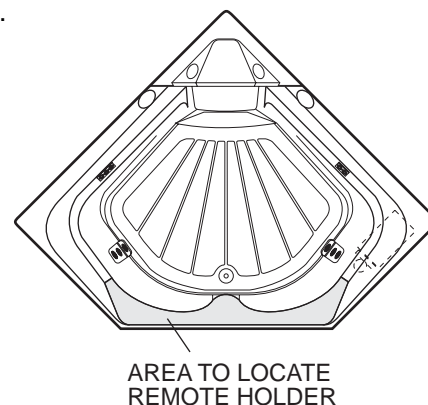

Controlling Whirlpool Action

The whirlpool action in your bath is influenced by three factors – direction of flow, force of water, and force of air.

Direction: To change the direction of the water flow, swivel the jet nozzle to the desired angle. The jets can be directed individually toward any location on your body to provide a hydromassage. The jets can also be adjusted so that they all point in the same direction (clockwise or counterclockwise) to circulate the water in a circular motion around the bath, causing a total whirlpool effect.

Water Force: The high volume, fully adjustable jets can be adjusted to control the force of the water coming into the bath. For robust action, increase the force of the flow by rotating the jet handles to the left (counterclockwise). For a more gentle effect, rotate the handles to the right (clockwise). **Never run the whirlpool system with all the jets closed.**

Force of Air: Four knobs located on the bath serve as controls for the air induction system. The intensity of the hydromassage whirlpool action is determined by the amount of air inducted into the water. As the amount of air is increased, the hydromassage action increases. For maximum air induction, rotate the control knobs fully counterclockwise to the largest circles. For fewer air bubbles, decrease the amount of air induction by rotating the control knob clockwise. When the knobs are turned to the smallest circles, only water is being circulated.

AIR INDUCTION CONTROLS

TURN CLOCKWISE TO
REDUCE AIR FLOW

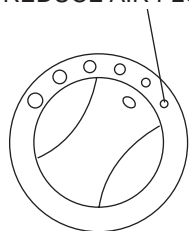

TURN COUNTER-CLOCKWISE
TO INCREASE AIR FLOW

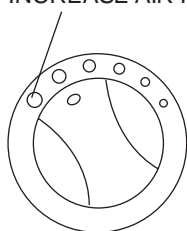

JETS

DIRECTIONALLY
ADJUSTABLE

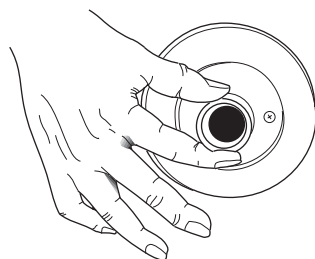

FULLY
ADJUSTABLE



CD/Radio

For operation of the CD/radio consult the manual enclosed.

Note: The remote for the CD/radio is not intended to be used inside the bath.

Note: For units with AM/FM radios, the quality of AM reception will vary by locality. Jacuzzi Whirlpool Bath is not responsible for the quality of AM reception.

TV

For operation of the TV consult the manual enclosed.

NOTE: In order to hear the TV audio, the Pioneer CD Receiver AUX function must be setup to be ON.

To perform this setting:

- If the unit is on, press SOURCE and hold until the unit turns off.
- Press FUNCTION repeatedly until AUX appears in the display
- Select AUX on and off with ▲/▼. The status will be displayed: AUX :ON

If power to the unit is interrupted, the CD Receiver will have to be reset.

Note: The remote for the TV is not intended to be used inside the bath.

RapidHeat

Once the heater is installed and the whirlpool pump is operating, the heating function is totally automatic. The heater will help maintain the temperature of the water in the bath.

Vacuum Switch

The heater is equipped with a preset vacuum switch which will not allow the heater to turn ON if the pump is not running with water flowing through the whirlpool system.

High-Limit Switch

The heater includes an exclusive High-Limit switch. This safety circuit will not false trip from hot tap water. It will only turn off the heater if the thermostat fails. To reset, press the button. If the high-limit trips frequently, contact your dealer.

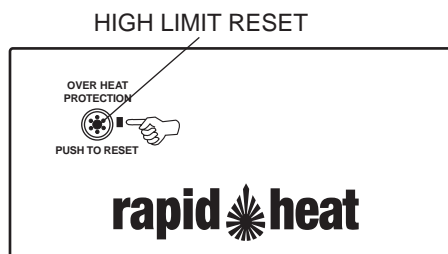

BATH MAINTENANCE

Cleaning the Bath

To clean your bath, simply use a mild, nonabrasive liquid detergent solution. You can protect and restore the gloss to a dulled acrylic surface by applying Meguiar's #10 Mirror Glaze, a product specifically designed for use on acrylic finishes. If Meguiar's is not available, an acrylic polish of equal quality or automotive paste wax is acceptable. **Never use abrasive household cleaners on any Jacuzzi Whirlpool Bath product.**

Repairs to the Surface

Minor scratches which do not penetrate the color finish can be removed by lightly sanding with 600-grit wet/dry sandpaper. Restore the gloss using Meguiar's Mirror Glaze or automotive paste wax.

Major scratches and gouges which penetrate the acrylic surface will require refinishing. Ask your Jacuzzi Whirlpool Bath dealer for special instructions.

Purging the Whirlpool System

NOTE: THE WHIRLPOOL SYSTEM SHOULD BE PURGED AT LEAST TWICE A MONTH

To remove accumulations of bath residue from the whirlpool system, it is recommended that a whirlpool bath be purged at least twice a month. For best results, however, we recommend that you purge your whirlpool bath after each use using our exclusive two-part plumbing system cleaner made specifically for whirlpool baths. Systems Clean™ is available through an authorized Jacuzzi Whirlpool Bath Distributor or by calling us direct at 1-800-288-4002. Instructions for use: Immediately after bathing and exiting the whirlpool bath, leave the bath water in the tub and add hot water, if necessary, so the water is at least 2" above the highest jet. Turn on the unit without the aerator. Pour the contents of the Systems Clean Packet 1 (taking care not to get the material on yourself) into the bath near the intake for the circulation pump. Repeat same process with Systems Clean Packet 2. **It is important to use Packet 1 before Packet 2 to avoid a strong odor.** Run the bath for 5 to 10 minutes. Drain completely and rinse any residue.

If you have followed the standard purging instructions above and still have an excess accumulation of bath residue and desire an alternative cleaning mechanism, we recommend **SUPER SYSTEMS CLEAN PLUS** manufactured by Stearns Packaging to rectify this condition. This may be obtained by contacting us at 1-800-288-4002. It is recommended that you follow the instructions provided by the manufacturer with the product. Repeated use may be necessary. **SUPER SYSTEMS CLEAN PLUS** does not replace the necessity to regularly purge your whirlpool system with Systems Clean as recommended.

(For additional information about water content, contact us for a copy of the Jacuzzi Water Quality Primer.)

Bath Additives

NOTE: DO NOT USE OIL OR OIL BASED BATH ADDITIVES.

If you want to use any kind of bath additive, use only a small amount of low-foaming powder or crystal substance; the whirlpool action intensifies the foaming properties of soaps.

The use of certain bath oils, bubble baths and bath additives may increase the level of accumulations of bath residue in the whirlpool system. If excess accumulations persist, you should discontinue use of these products.

Spinning Neck Jets

If hair or other kind of debris gets caught in the bearings of these jets, it could cause them to stop spinning. This may require disassembly and cleaning. To do this, simply grab the nozzle and pull straight out of the jet housing. The roller bearing casing will be attached to the nozzle. These can be separated by holding the casing and pushing the nozzle out from the rear of the casing. After cleaning, reassemble in reverse.

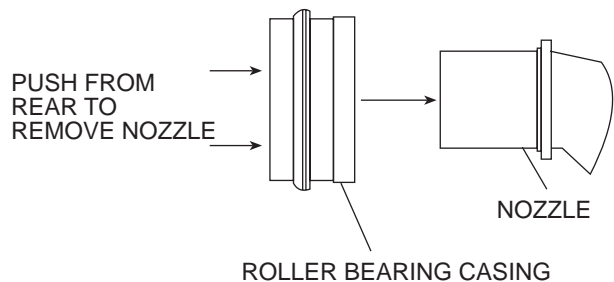

Suction Cover/Strainer Maintenance

Clean the suction cover/strainer of hair and debris when necessary. To do this, remove the center screw and detach the square cover. Clean the cover by backflushing debris from the holes. Replace the suction cover immediately after cleaning. When reinstalling, orient the cover/strainer with the small notch at the bottom. The gasket must be inserted into the groove of the cover/strainer before reinstalling onto the suction fitting.

CAUTION: Keep hair a minimum of 6 inches away from the suction fitting at all times when the whirlpool system is operating. Hair longer than shoulder length should be secured close to the head. Do not operate the whirlpool system with the suction cover removed! It is a safety device and must always be in place on the suction fitting to minimize the potential hazard of hair and body entrapment.

SUCTION COVER/STRAINER ASSEMBLY

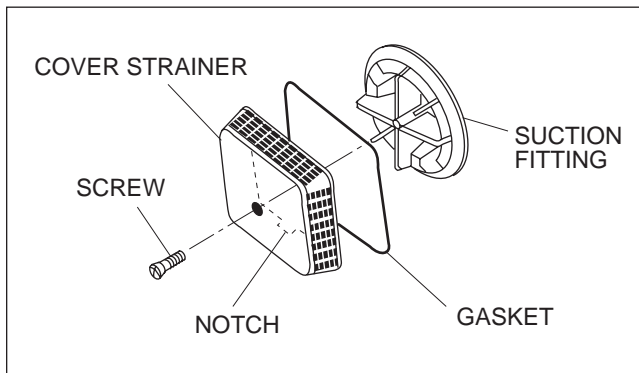

Lamp

When the bulb burns out, replace it from the **back** of the lamp fitting, on the underside of the shell, by pulling out the bulb receptacle. Replacement bulbs (7W, 12V) are available from your Jacuzzi Whirlpool Bath dealer.

LIGHT BULB REPLACEMENT

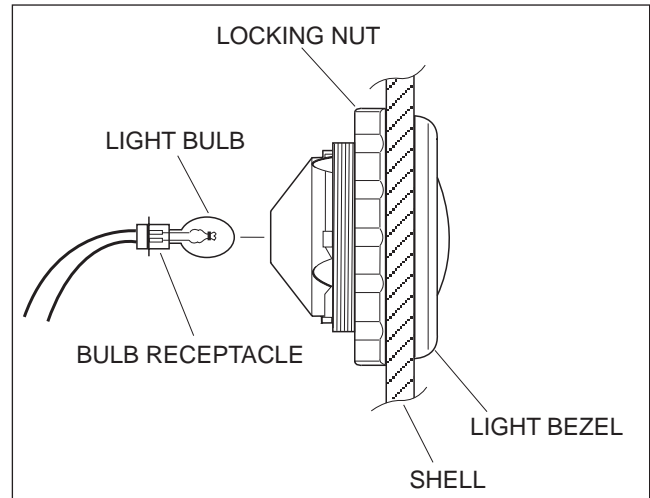

**PRODUCT SPECIFICATIONS ARE SUBJECT TO CHANGE WITHOUT NOTICE.
USE INSTALLATION INSTRUCTIONS SUPPLIED WITH PRODUCT.**

Jacuzzi Whirlpool Bath has obtained applicable code (standards) listings generally available on a national basis for products of this type. It is the responsibility of the installer/owner to determine specific local code compliance prior to installation of this product. Jacuzzi Whirlpool Bath makes no representation or warranty regarding, and will not be responsible for any code compliance.

Jacuzzi Whirlpool Bath
P.O. Box 702168, Dallas, TX 75370-2168
Service Support: Call (800) 288-4002

©2000 Jacuzzi Whirlpool Bath S198000 8/16/04

TEMPLATE FOR CD/RADIO MOUNTING SLEEVE

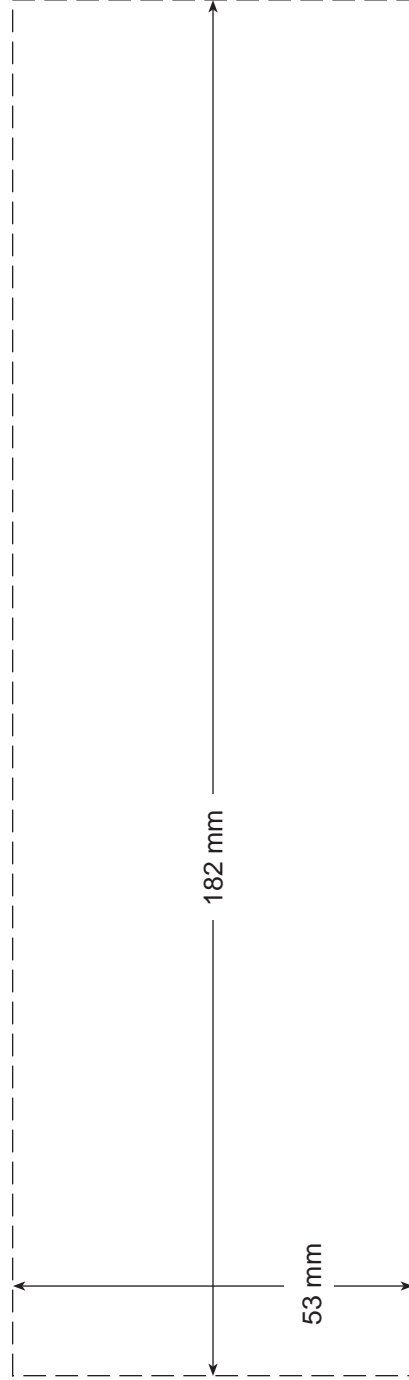

Jacuzzi Whirlpool Bath Limited Warranty

Designer Collection Bath Product

WARRANTY COVERAGE

Jacuzzi Whirlpool Bath (the "Company") offers the following express limited warranty to the original purchaser of any Jacuzzi Whirlpool Bath Designer Collection Bath Product ("unit") who purchases the product for personal or single family use ("user"). The Company will repair or replace, at its option, the unit or its equipment in accordance with the following terms and conditions.

TWO YEAR LIMITED WARRANTY ON BATHS

Our limited warranty on Designer Collection Bath products is for two (2) years. Our warranty covers the unit and factory-installed components (e.g., pump, motor) against defects in material or workmanship. Warranty coverage begins on the date the unit was originally purchased by the user.

FIVE YEAR (PARTS ONLY) LIMITED WARRANTY ON PUMP AND MOTOR

Our limited warranty on the pump and motor is for five (5) years for parts only. Warranty coverage begins on the date the unit was originally purchased by the user.

NINETY DAY (PARTS ONLY) LIMITED WARRANTY ON OPTIONS AND ACCESSORIES

Our limited warranty on options and accessories manufactured by the Company is for ninety (90) days for parts only. Our warranty covers options and accessories manufactured by the Company (e.g., fill spout kits, trim kits, skirts) against defects of material or workmanship. Warranty coverage begins on the date the option or accessory was originally purchased by the user.

WARRANTY LIMITATIONS

Our limited warranty does not cover defects, damage, or failure caused by the common carrier, installer, user, or other person, or resulting from, without limitation, any of the following: careless handling (lifting unit by plumbing, abrading finish, etc.); modification of any type for any reason (including modification to meet local codes); improper installation (including installation not in accordance with instructions and specifications provided with the unit); connections supplied by the installer of the equipment; improper voltage supply or unauthorized electrical modification; misuse; incorrect operation, or lack of proper routine maintenance; operation of the unit without specified minimum amount of water or at inappropriate water temperature; use of abrasive or improper cleaners; or acts of God, such as lightning, floods, earthquakes, etc.

In addition, THE COMPANY WILL NOT BE RESPONSIBLE FOR INCIDENTAL OR CONSEQUENTIAL DAMAGES or losses arising from any cause (e.g., water damage to carpet, ceiling, loss of use, etc.) including its own negligence; damages to, respecting, or resulting from: plated parts when pool and/or spa chemicals are used in the unit; optional bath equipment not manufactured by the Company but supplied by Dealer, installer or the Company; the unit's prior usage as an operational display; or defects that should have been discovered before installation. This limited warranty does not include: labor, transportation, or other costs incurred in the removal and/or reinstallation of the original unit and/or installation of a replacement unit; any costs relating to obtaining access for repair; or loss of use damage, including loss of sales, profit or business advantage of any kind under any circumstances. Bath units are excluded from any warranty coverage if any addition, deletion, or modification of any kind whatsoever has been made to the unit (or to any component).

Warranty coverage is provided in the United States of America only.

EXCLUSION OF IMPLIED WARRANTIES

IMPLIED WARRANTIES OF MERCHANTABILITY AND FITNESS FOR A PARTICULAR PURPOSE ARE DISCLAIMED ALTOGETHER OR TO THE FULL EXTENT ALLOWED BY LAW.

NOTICE: This warranty gives you specific legal rights, and you may also have other rights which vary from state to state. There are no warranties applicable to Jacuzzi Whirlpool Bath products except as expressly stated herein or as implied by applicable state and federal laws. The Company will not be responsible for any statements or representations made in any form that go beyond, are broader than or are inconsistent with any authorized literature or specifications furnished by the Company.

Some states do not allow limitations on how long an implied warranty lasts, or the exclusion or limitation of incidental or consequential damages, so the above limitations and exclusions may not apply to you.

RETURN OF WARRANTY CARD

The attached Warranty Registration Card MUST be filled out by the purchaser within thirty (30) days from purchase and mailed to Jacuzzi Whirlpool Bath in order for this warranty to become effective.

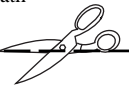

Jacuzzi Whirlpool Bath
P.O. Box 702168
Dallas, TX 75370-2168

RESPONSIBILITIES OF OTHERS

Inspecting the unit prior to installation is the responsibility of the installer or building contractor who acts on behalf of the user. They are responsible for ensuring the unit is free of defect or damage. Notices are placed on and in the unit and on the shipping carton advising the installer of this responsibility. In the event of a problem, the unit must not be installed. The Company is not responsible for failures or damage that could have been discovered, repaired, or avoided by proper inspection and testing prior to installation.

Damage occurring in transit is the responsibility of the carrier. The user or installer MUST open the crate and inspect the unit for damage when it is delivered. If damage is discovered, it must be reported immediately to the seller and the carrier in writing, and an inspection requested. Failure of the carrier to respond should be reported to the seller and the carrier. Your freight claims should be filed promptly thereafter.

It is the responsibility of the installer, building contractor, or user to provide access for service. The Company is not responsible for any costs relating to obtaining access for repair. The user shall bear such costs and, if appropriate, must seek recovery from the installer.

Damage occurring to the unit during installation is the responsibility of the installer and/or building contractor and damage occurring thereafter is the responsibility of the user.

Failure of any optional equipment is the sole responsibility of the equipment manufacturer. (Options and accessories manufactured by the Company are warranted for ninety (90) days from the original date of purchase for parts only.)

The Distributor or Dealer is responsible for knowing local code requirements and notifying the installing contractor and/or user of these requirements at the time of purchase. The Company is not responsible for costs to modify any product to obtain any code approval, such as city, county, or state building codes.

WARRANTY SERVICE

For the customer's benefit, the Company maintains a list of independent service personnel to perform required warranty service repairs. Such firms are not agents or representatives of the Company and cannot bind the Company by words or conduct.

The Company will provide the warranty service described above when the following conditions have been met: the failure is of the nature or type covered by the warranty; the user has informed an Authorized Jacuzzi Whirlpool Bath Service Agent or Warranty Service Department Representative of the nature of the problem during the warranty period; conclusive evidence (e.g., proof of purchase or installation) is provided to the foregoing by the user proving that the failure occurred or was discovered within the warranty period; an authorized independent service person or Company representative has been permitted to inspect the unit during regular business hours within a reasonable time after the problem was reported by the user.

In order to obtain warranty service, consult your local telephone book for the location of the nearest Jacuzzi Whirlpool Bath Authorized Service Agent. Describe the problem and the Authorized Service Agent will inspect the unit and provide the required warranty service.

If you are unable to contact a Jacuzzi Whirlpool Bath Authorized Service Agent, call or write:

Jacuzzi Whirlpool Bath
Warranty Service Department
P.O. Box 702168
Dallas, TX 75370-2168
Call: (800) 288-4002

To obtain warranty replacement for factory-installed components for Company supplied options and accessories manufactured and supplied by the Company, call or write the above. Provide a description of the problem and proof of purchase. You will be instructed how to obtain replacements and where to return, at your expense, the failed component(s), option(s), or accessory(ies).

All replacement parts, equipment, and repairs shall assume the remaining warranty period of the part(s) replaced.

The Company's warranty obligation shall be discharged upon tender of replacement or repair. The customer's refusal to accept the tender terminates the Company's warranty obligation.

©2000 Jacuzzi Whirlpool Bath S198000 8/16/04

Ninety-Day
Parts Only
Limited Warranty
On
Accessory(ies)



Warranty Registration Card

This card must be filled out and returned to the address printed on the other side within thirty (30) days from date of purchase in order for this warranty to be come effective.

Purchaser's Name _____

Purchaser's Address _____ State _____ Zip _____

Date of Purchase _____

Model Name _____

Serial Number _____

Dealer's Name _____

Dealer's Address _____

1. How did you first hear about this Jacuzzi® product?
 - Advertisement Article in Magazine/Newspaper
 - Visited Dealer/Plumbing Supplier Yellow Pages
 - Builder/Plumber/Remodeler Decorator/Architect
 - Visited Retailer/Home Center Store
 - Word of Mouth . . . Friend/Relative/acquaintance
 - Other (Please Describe) _____
2. Who first gave you specific information about this product (specifications, prices, etc.)?
 - Dealer/Plumbing Supplier Builder Remodeler
 - Plumbing Contractor Retailer/Home Center Store
 - Decorator/Architect Already Installed
3. What was the main reason for purchase?
 - Styling Warranty Service Product Features
 - Brand Name Price Hydrotherapy
 - Home Resale
 - Other _____
4. Who finally decided which product you would buy?
 - Self Spouse Self and Spouse Together
 - Other Family Member Designer/Architect
 - Builder/Plumber/Remodeler Already Installed
5. Who installed?
 - Contractor/Plumber when remodeling
 - Self/Spouse when remodeling
 - Other _____
6. What is the current market value of this property? _____
7. Please estimate \$ _____
8. What other manufacturers did you consider? _____ years
- Eljer Lasco Price Pfister Aqua Glass
 - Kohler American Standard Sterling
9. How long did you shop before purchasing unit?
 - 1 day 2 months-6 months
 - 2-7 days 6 months-1 year
 - 1 week-2 weeks 1 year-2 years
 - 2 weeks-4 weeks +2 years
 - 1 month-2 months
10. Approximately how long have you lived in this home? _____ household.
11. Please indicate, approximately, the total annual income of your household.
 - Up to \$24,999 \$50,000 to \$74,999
 - \$25,000 to \$29,999 \$75,000 to \$99,999
 - \$30,000 to \$39,999 \$100,000 to \$149,999
 - \$40,000 to \$49,999 \$150,000 and Above
12. Was your purchase process?
 - Very easy Easy Difficult Very Difficult
13. How technically aware were you of the patented Jacuzzi® jet system prior to your purchase?
 - Not aware Somewhat aware Very aware

Ninety-Day
Parts Only
Limited Warranty
On
Accessory(ies)

Jacuzzi Whirlpool Bath
S198000
8/16/04