

# KFC-87E

## SERVICE MANUAL

# KENWOOD

©1990-2 PRINTED IN JAPAN  
B51-6132-00(T) 1201

### EXTERNAL VIEW

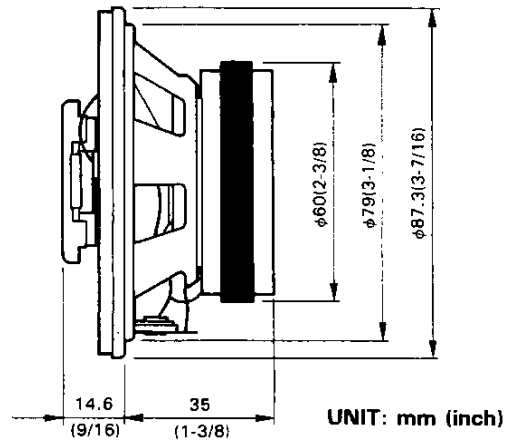
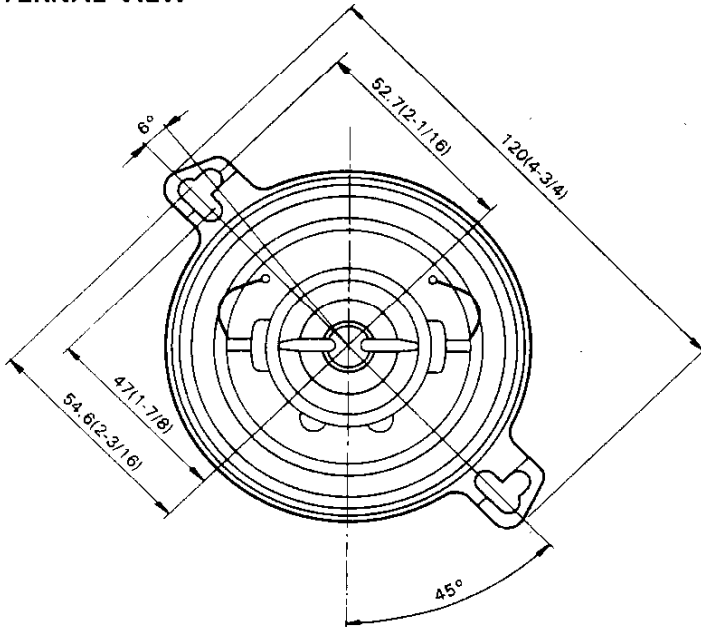

### PARTS INCLUDED

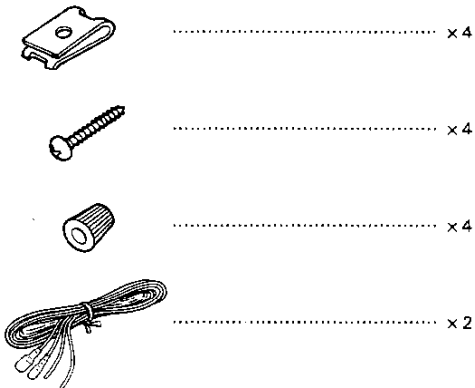

### PARTS LIST

★ New parts  
Parts without **Parts No.** are not supplied.  
Les articles non mentionnés dans le **Parts No.** ne sont pas fournis.  
Teile ohne **Parts No.** werden nicht geliefert.

Ref No.	New Parts	Parts No.	Description
	★	E30-5028-08	CORD SET
	★	N99-1153-08	SCREW SET
	★	T15-0158-08	SPEAKER

### SPECIFICATIONS

- Speakers
- Woofers ..... 8.7 cm (3-1/2 in)  
Cone Type  
85 g (3 oz)
  - Ceramic Magnet
  - Tweeters ..... 2.5 cm (1 in)  
Balanced Dome Type
  - Peak Power ..... 30 Watts
  - Frequency Response ..... 65 Hz ~ 22,000 Hz
  - Sensitivity ..... 89 dB/W at 1 m
  - Impedance ..... 4 ohms
  - Weight per speaker ..... 0.76 kg (1 lb 11 oz)/pc.

(KENWOOD follows a policy of continuous advancements in development.  
For this reason specifications may be changed without notice.)

**Q.C.**  
**COPY**