

Attachment Illustrated Parts List



Attachment

Mfg. No.	Description
1695168	Catcher, Clean Sweep Twin, 38"

Simplicity

MANUFACTURING, INC.
500 N. Spring Street / PO Box 997
Port Washington, WI 53074-0997 USA

www.simplicitymfg.com

© Copyright 2007 Simplicity Manufacturing, Inc. All Rights Reserved. Printed In USA.

Part No.: 1734816

Rev. 04/2007

TP 400-4537-00-AT-SMA

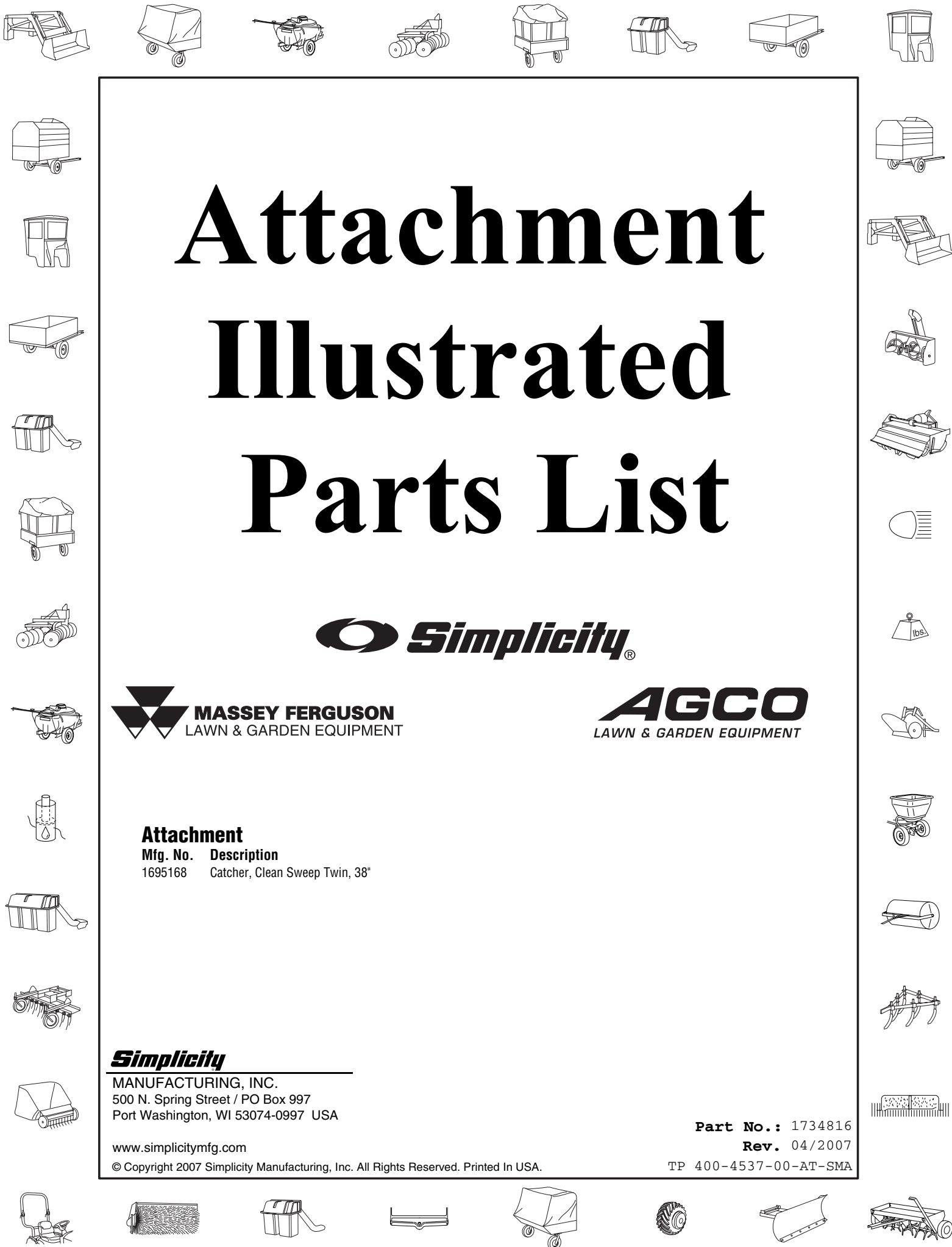

PRODUCT COMPONENTS	PAGES
Twin Catcher Assembly	4
Torque Specification Chart	Inside Back Cover

Twin Catcher Assembly

NOTE: Unless noted otherwise,
use the standard hardware torque
specification chart.

1695168

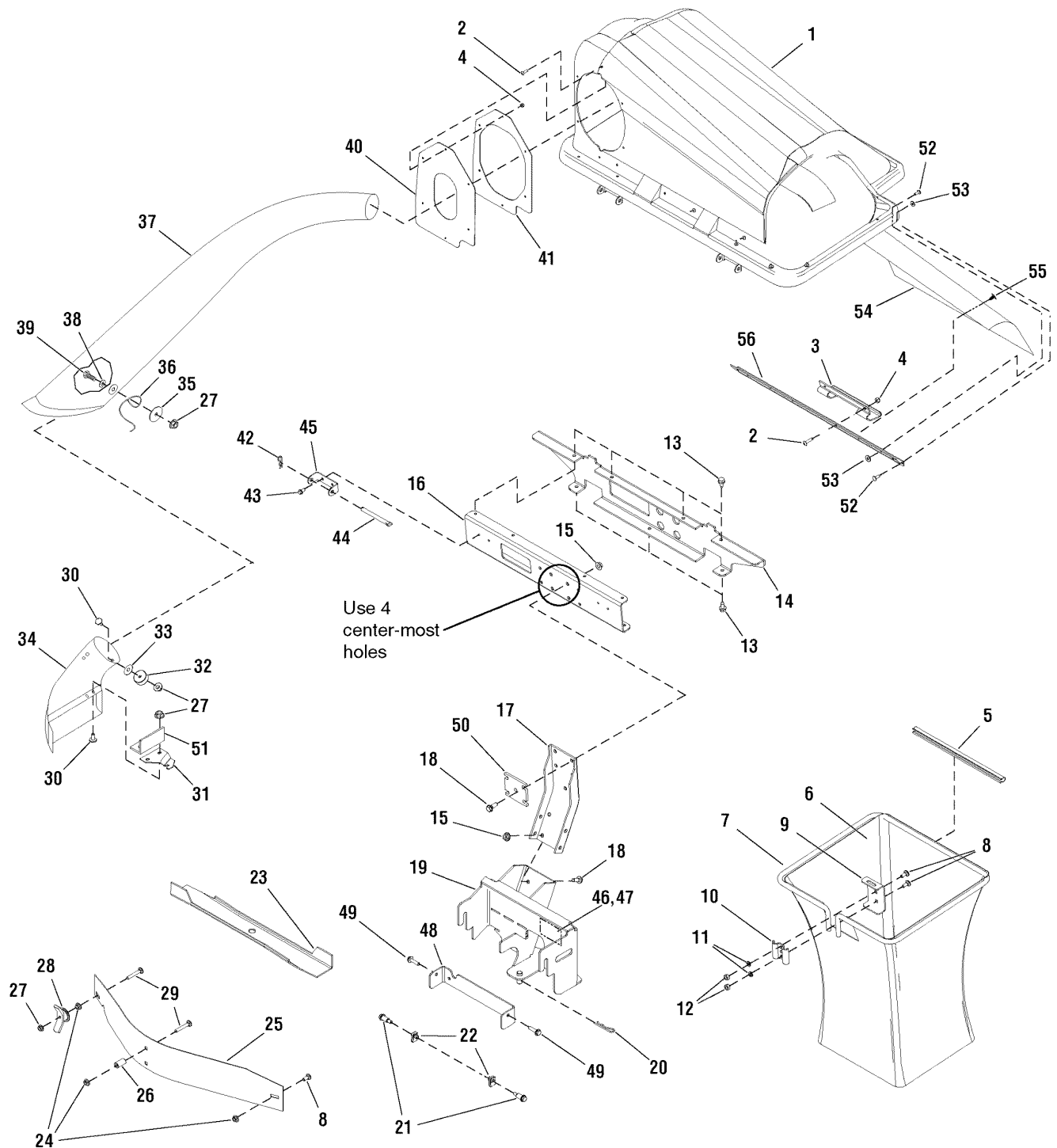

The above parts group applies to the following Mfg. Nos.:
1695168 - Catcher

Twin Catcher Assembly

REF NO	PART NO.	QTY.	DESCRIPTION
1	1733564SM	1	COVER ASSEMBLY, Twin Catcher
2	1960404SM	8	SCREW, Truss Head Phillips, 10 - 24 x 3/4
3	054537MA	1	HANDLE, Plastic
4	1933896SM	8	NUT, Hex Lock w/Nylon Insert, 10 - 24
5	1675707SM	2	CLIP, Tube Grass Bag
6	1703764SM	2	BAG, Grass White Poly
7	1733491SM	2	HOOP, Twin
8	1931333SM	5	BOLT, Carriage, 5/16 - 18 x 3/4 (Qty. of 1 included in Ref. No 57)
9	1703807ASM	2	HANGER, Grass Bag
10	1672023ASM	2	CLAMP, Grass Bag Plain
11	1917356SM	4	LOCKWASHER, Spring, 5/16
12	1917372SM	4	NUT, Hex, 5/16 - 18
13	1664847SM	7	SCREW, Hex Washer Head Taptite, 5/16 - 18 x 3/4
14	1733613ASM	1	BRACKET, Tab Cross Support Twin
15	1928352SM	8	NUT, Hex Whiz Lock Flange (Included in Ref. No 57)
16	1734228ASM	1	CHANNEL, Cross Support Twin
17	1707526ASM	1	SUPPORT, Upright
18	1934654SM	8	SCREW, Hex Whiz Lock Flange (Included in Ref. No 57)
19	1733627SM	1	SUPPORT ASSEMBLY, Regent Catcher
20	1960033SM	1	CLIP, Hair Pin (Included in Ref. No 57)
21	1728976SM	2	BOLT, Shoulder, 5/16 - 18 (Included in Ref. No 57)
22	1960717SM	2	NUT, Speed, 5/16 - 18 (Included in Ref. No 57)
23	1704977SM	1	BLADE, Mower 22.3" Hi-Lift
24	1927557SM	4	NUT, Hex Whiz Lock Flange, 5/16-18 (Included in Ref. No 57)
25	1703765ASM	1	BAFFLE, 38"
26	1674669SM	2	SPACER (Included in Ref. No 57)
27	1935048SM	5	NUT, Hex Two-Way Lock Flange, 5/16 - 18 (Qty. of 4 included in Ref. No 57)
28	1679163SM	1	WINGNUT ASSEMBLY (Included in Ref. No 57)
29	1931339SM	3	BOLT, Carriage, 5/16 - 18 x 2 (Included in Ref. No 57)
30	1960371SM	3	SCREW, Hex Head, 5/16 - 18 x 3/4 (Included in Ref. No 57)
31	1704355ASM	1	BRACKET, Offset (Included in Ref. No 57)
32	1704341SM	1	WASHER, Special (Included in Ref. No 57)
33	1920283SM	1	WASHER (Included in Ref. No 57)
34	1732561SM	1	ADAPTER, 38"
35	1960185SM	1	WASHER, 5/16
36	1704603SM	1	LATCH, Tube
37	1703769SM	1	TUBE, Transfer
38	1919326SM	1	WASHER, 5/16
39	1960122SM	1	SCREW, Hex Head, 5/16 - 18 x 3/4
40	1733741SM	1	SEAL, Cover
41	1732735ASM	1	FLANGE, Seal
42	1960074SM	2	CLIP, Hair Pin (Included in Ref. No 57)
43	1925003SM	4	SCREW, Hex Washer Head Taptite, 1/4 - 20 x 1/2
44	054407ZMA	2	PIN, Cover Hinge (Included in Ref. No 57)

Footnotes

The above parts group applies to the following Mfg. Nos.:

1695168 - Catcher

Twin Catcher Assembly

NOTE: Unless noted otherwise,
use the standard hardware torque
specification chart.

1695168

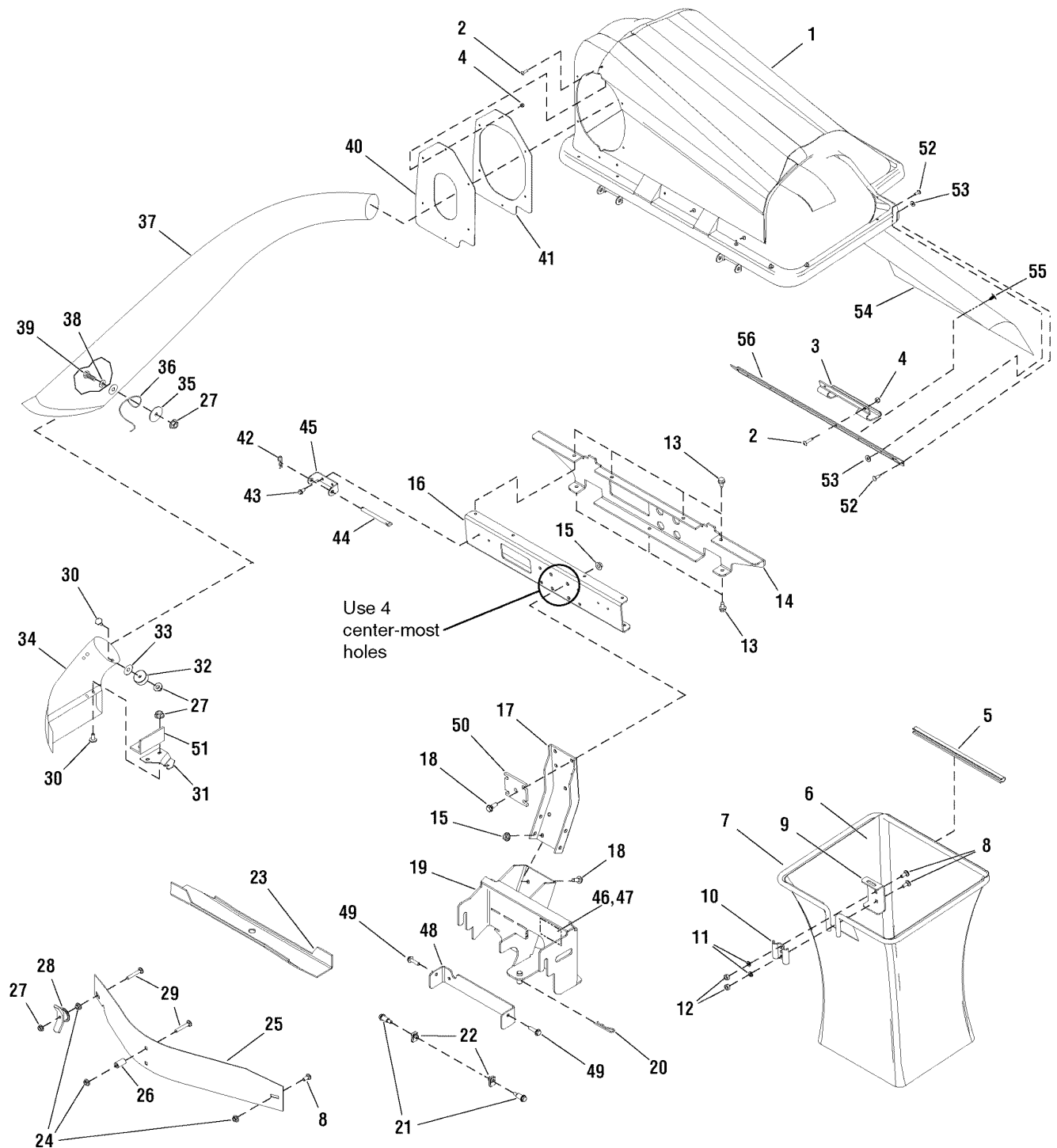

The above parts group applies to the following Mfg. Nos.:
1695168 - Catcher

Twin Catcher Assembly

REF NO	PART NO.	QTY.	DESCRIPTION
48	1733903ASM	1	PLATE, Reinforcement
49	1930595SM	2	SCREW, Hex Whiz Lock Flange, 5/16 - 18 x 1-1/4 (Included in Ref. No 57)
50	1733948ASM	1	PLATE, Reinforcement, Upright (Included in Ref. No 57)
51	1733970ASM	1	BRACKET, Deflector Prop (Included in Ref. No 57)
52	1673320SM	18	RIVET, Pop, 3/16
53	1910531SM	12	WASHER, Rivet, 3/16
54	1732488SM	1	SCREEN, Twin Cover
55	1732490SM	6	FASTENERS, Push, 1/4 x 1/2
56	1734384SM	1	SCREEN SUPPORT, Twin
57	1660950SM	1	HARDWARE BAG (Not Shown. Includes Ref. Nos. 8, 15, 18, 20, 21, 22, 24, 26, 27, 28, 29, 30, 31, 32, 33, 42, 44, 49, 50 & 51)
--	1733729	1	INSTRUCTION MANUAL

Footnotes

The above parts group applies to the following Mfg. Nos.:

1695168 - Catcher

Hardware Identification & Torque Specifications

Common Hardware Types

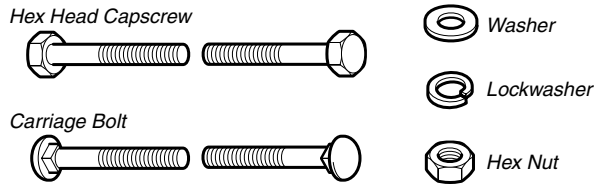

Standard Hardware Sizing

When a washer or nut is identified as **1/2"**, this is the *Nominal size*, meaning the *inside diameter* is 1/2 inch; if a second number is present it represent the *threads per inch*

When bolt or capscrew is identified as **1/2 - 16 x 2"**, this means the *Nominal size*, or *body diameter* is 1/2 inch; the second number represents the *threads per inch* (16 in this example, and the final number is the *body length* of the bolt or screw (in this example 2 inches long).

The guides and ruler furnished below are designed to help you select the appropriate hardware and tools.

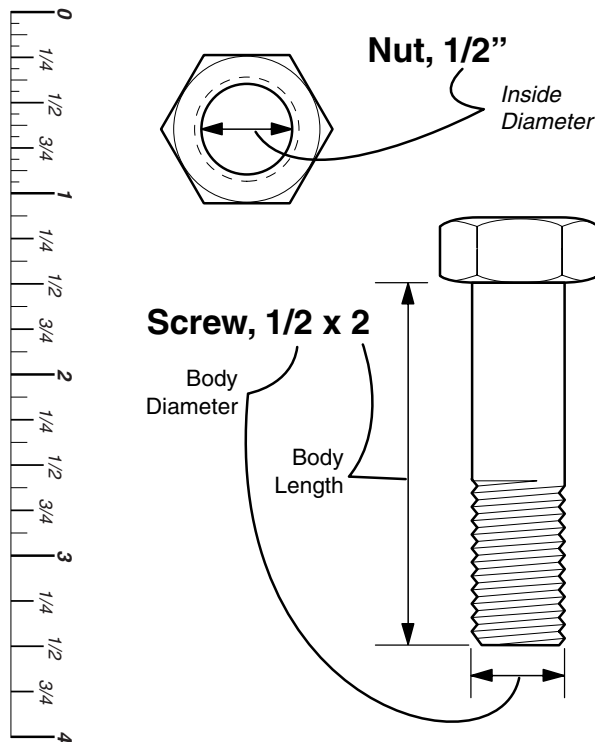

Torque Specification Chart						
FOR STANDARD MACHINE HARDWARE (Tolerance ± 20%)						
Hardware Grade	No Marks SAE Grade 2		SAE Grade 5		SAE Grade 8	
	in/lbs ft/lbs	Nm.	in/lbs ft/lbs	Nm.	in/lbs ft/lbs	Nm.
8-32	19	2.1	30	3.4	41	4.6
8-36	20	2.3	31	3.5	43	4.9
10-24	27	3.1	43	4.9	60	6.8
10-32	31	3.5	49	5.5	68	7.7
1/4-20	66	7.6	8	10.9	12	16.3
1/4-28	76	8.6	10	13.6	14	19.0
5/16-18	11	15.0	17	23.1	25	34.0
5/16-24	12	16.3	19	25.8	27	34.0
3/8-16	20	27.2	30	40.8	45	61.2
3/8-24	23	31.3	35	47.6	50	68.0
7/16-14	30	40.8	50	68.0	70	95.2
7/16-20	35	47.6	55	74.8	80	108.8
1/2-13	50	68.0	75	102.0	110	149.6
1/2-20	55	74.8	90	122.4	120	163.2
9/16-12	65	88.4	110	149.6	150	204.0
9/16-18	75	102.0	120	163.2	170	231.2
5/8-11	90	122.4	150	204.0	220	299.2
5/8-18	100	136	180	244.8	240	326.4
3/4-10	160	217.6	260	353.6	386	525.0
3/4-16	180	244.8	300	408.0	420	571.2
7/8-9	140	190.4	400	544.0	600	816.0
7/8-14	155	210.8	440	598.4	660	897.6
1-8	220	299.2	580	788.8	900	1,244.0
1-12	240	326.4	640	870.4	1,000	1,360.0

NOTES

- These torque values are to be used for all hardware excluding: locknuts, self-tapping screws, thread forming screws, sheet metal screws and socket head setscrews.
- Recommended seating torque values for locknuts:
 - for prevailing torque locknuts - use 65% of grade 5 torques.
 - for flange whizlock nuts and screws - use 135% of grade 5 torques.
- Unless otherwise noted on assembly drawings, all torque values must meet this specification.

Wrench & Fastener Size Guide



1/4" Bolt or Nut
Wrench—7/16"

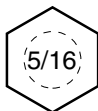

5/16" Bolt or Nut
Wrench—1/2"

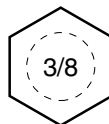

3/8" Bolt or Nut
Wrench—9/16"



7/16" Bolt or Nut
Wrench (Bolt)—5/8"
Wrench (Nut)—11/16"

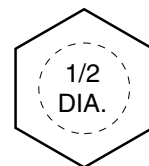

1/2" Bolt or Nut
Wrench—3/4"

