

**acer**

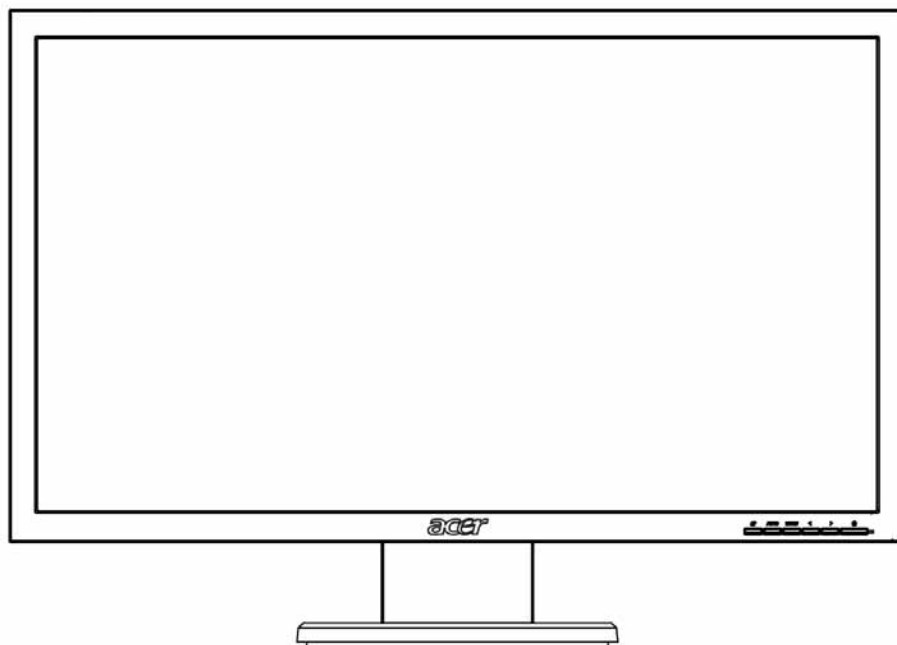

**Acer G195HQ  
Service Guide**

### Service Guide Version and Revision

Version	Release Date	Revision History	Customer model	TPV model
A00	Sep-10-2009	Initial Release	G195HQ	T89AM6D8MXAFH2
				T89AM5D8MXAFN2

**Copyright**

Copyright © 2009 by Acer Incorporated. All rights reserved. No part of this publication may be reproduced, Transmitted, transcribed, stored in a retrieval system, or translated into any language or computer language, in any form or by any means, electronic, mechanical, magnetic, optical, chemical, manual or otherwise, without the prior written permission of Acer Incorporated.

**Disclaimer**

The information in this guide is subject to change without notice. Acer Incorporated makes no representations or warranties, either expressed or implied, with respect to the contents hereof and specifically disclaims any warranties of merchantability or fitness for any particular purpose. Any Acer Incorporated software described in this manual is sold or licensed "as is". Should the programs prove defective following their purchase, the buyer (and not Acer Incorporated, its distributor, or its dealer) assumes the entire cost of all necessary servicing, repair, and any incidental or consequential damages resulting from any defect in the software.

Intel is a registered trademark of Intel Corporation.

Pentium and Pentium II/III are trademarks of Intel Corporation.

Other brand and product names are trademarks and/or registered trademarks of their respective holders.

**Trademarks**

Acer is a registered trademark of Acer Incorporated.

All other trademarks are property of their respective owners.

**Conventions**

The following conventions are used in this manual:

Screen messages	Denotes actual messages that appear on screen.
Note	Gives bits and pieces of additional information related to the current topic.
Warning	Alerts you to any damage that might result from doing or not doing specific actions.
Caution	Gives precautionary measures to avoid possible hardware or software problems.
Important	Remind you to do specific actions relevant to the accomplishment of procedures.

## Preface

Before using this information and the product it supports, please read the following general information.

1. This Service Guide provides you with all technical information relating to the BASIC CONFIGURATION decided for Acer's "global" product offering. To better fit local market requirements and enhance product competitiveness, your regional office may have decided to extend the functionality of a machine (e.g. add-on card, modem, or extra memory capability). These LOCALIZED FEATURES will NOT be covered in this generic service guide. In such cases, please contact your regional offices or the responsible personnel/channel to provide you with further technical details.
2. Please note WHEN ORDERING FRU PARTS, that you should check the most up-to-date information available on your regional web or channel. If, for whatever reason, a part number change is made, it will not be noted in the printed Service Guide. For ACER-AUTHORIZED SERVICE PROVIDERS, your Acer office may have a DIFFERENT part number code to those given in the FRU list of this printed Service Guide. You MUST use the list provided by your regional Acer office to order FRU parts for repair and service of customer machines.

### Warning: (For FCC Certified Models)

**Note:** This equipment has been tested and found to comply with the limits for a Class B digital device, pursuant to Part 15 of the FCC Rules. These limits are designed to provide reasonable protection against harmful interference in a residential installation. This equipment generates, uses and can radiate radio frequency energy, and if not installed and used in accordance with the instructions, may cause harmful interference to radio communications. However, there is no guarantee that interference will not occur in a particular installation. If this equipment does cause harmful interference to radio or television reception, which can be determined by turning the equipment off and on, the user is encouraged to try to correct the interference by one or more of the following measures:

1. Reorient or relocate the receiving antenna.
2. Increase the separation between the equipment and receiver.
3. Connect the equipment into an outlet on a circuit different from that to which the receiver is connected.
4. Consult the dealer or an experienced radio/TV technician for help.

### Notice:

1. The changes or modifications not expressly approved by the party responsible for compliance could void the user's authority to operate the equipment.
2. Shielded interface cables and AC power cord, if any, must be used in order to comply with the emission limits.
3. The manufacturer is not responsible for any radio or TV interference caused by unauthorized modification to this equipment. It is the responsibility of the user to correct such interference.

As ENERGY STAR<sup>®</sup> Partner our company has determined that this product meets the ENERGY STAR<sup>®</sup> guidelines for energy efficiency.

### Warning:

To prevent fire or shock hazard, do not expose the monitor to rain or moisture. Dangerous high voltages are present inside the monitor. Do not open the cabinet. Refer servicing to qualified personnel only.

## Precautions

- Do not use the monitor near water, e.g. near a bathtub, washbowl, kitchen sink, laundry tub, swimming pool or in a wet basement.
- Do not place the monitor on an unstable trolley, stand, or table. If the monitor falls, it can injure a person and cause serious damage to the appliance. Use only a trolley or stand recommended by the manufacturer or sold with the monitor. If you mount the monitor on a wall or shelf, use a mounting kit approved by the manufacturer and follow the kit instructions.
- Slots and openings in the back and bottom of the cabinet are provided for ventilation. To ensure reliable operation of the monitor and to protect it from overheating, be sure these openings are not blocked or covered. Do not place the monitor on a bed, sofa, rug, or similar surface. Do not place the monitor near or over a radiator or heat register. Do not place the monitor in a bookcase or cabinet unless proper ventilation is provided.
- The monitor should be operated only from the type of power source indicated on the label. If you are not sure of the type of power supplied to your home, consult your dealer or local power company.
- The monitor is equipped with a three-pronged grounded plug, a plug with a third (grounding) pin. This plug will fit only into a grounded power outlet as a safety feature. If your outlet does not accommodate the three-wire plug, have an electrician install the correct outlet, or use an adapter to ground the appliance safely. Do not defeat the safety purpose of the grounded plug.
- Unplug the unit during a lightning storm or when it will not be used for long periods of time. This will protect the monitor from damage due to power surges.
- Do not overload power strips and extension cords. Overloading can result in fire or electric shock.
- Never push any object into the slot on the monitor cabinet. It could short circuit parts causing a fire or electric shock. Never spill liquids on the monitor.
- Do not attempt to service the monitor yourself; opening or removing covers can expose you to dangerous voltages and other hazards. Please refer all servicing to qualified service personnel
- To ensure satisfactory operation, use the monitor only with UL listed computers which have appropriate configured receptacles marked between 100 - 240V AC, Min. 5A.
- The wall socket shall be installed near the equipment and shall be easily accessible.

## Special Notes on LCD Monitors

The following symptoms are normal with LCD monitor and do not indicate a problem.

### Notes

- Due to the nature of the fluorescent light, the screen may flicker during initial use. Turn off the Power Switch and then turn it on again to make sure the flicker disappears.
- You may find slightly uneven brightness on the screen depending on the desktop pattern you use.
- The LCD screen has effective pixels of 99.99% or more. It may include blemishes of 0.01% or less such as a missing pixel or a pixel lit all of the time.
- Due to the nature of the LCD screen, an afterimage of the previous screen may remain after switching the image, when the same image is displayed for hours. In this case, the screen is recovered slowly by changing the image or turning off the Power Switch for hours.

## Table of Contents

<b>Chapter 1</b>	<b>Monitor Features</b>	<b>7</b>
	Introduction	7
	Electrical Requirements	8
	LCD Monitor General Specification	9
	LCD Panel Specification	11
	Factory Preset Timing	13
	Monitor Block Diagram	14
	Main Board Diagram	15
	Power Board Diagram	16
	Software Flow chart	17
	Main Board Layout	19
	Installation	20
<b>Chapter 2</b>	<b>Operating Instructions</b>	<b>22</b>
	User Controls	22
	Front Panel Controls	22
	eColor Management (OSD)	23
	How to Adjust a Setting	23
	How to Optimize The DOS-Mode	26
	Enter into the factory mode	26
<b>Chapter 3</b>	<b>Machine Disassembly</b>	<b>27</b>
<b>Chapter 4</b>	<b>Troubleshooting</b>	<b>33</b>
<b>Chapter 5</b>	<b>Connector Information</b>	<b>39</b>
<b>Chapter 6</b>	<b>FRU (Field Replacement Unit) List</b>	<b>40</b>
	Exploded Diagram	40
<b>Chapter 7</b>	<b>Schematic Diagram</b>	<b>45</b>

**Introduction****Scope**

This short specification describes the electrical, optical and functional performance requirements for a 47cm (18.5") TFT LCD color monitor with VGA&DVI compatible interface.

**Description**

The LCD monitor is designed with the latest LCD technology to provide a performance oriented product with no radiation. This will alleviate the growing health concerns. It is also a space saving design, allowing more desktop space, and comparing to the traditional CRT monitor, it consumes less power and gets less weight in addition MTBF target is 50k hours or more.

**Chart of G195HQ**

Panel	M185XW01
Signal Interface	D-Sub 15pin; DVI 24pin(Dual-Input Model);
Sync Type	Separate / Compatible
Color Temp User Adjust	Support
DDC	DDC2B
Speaker	Option
Headphone Jack	Option
Microphone Jack	No
USB Hub	No
Tilt / Swivel	Yes /No

# Electrical Requirements of G195HQ

## Standard Test Conditions

All tests shall be performed under the following conditions, unless otherwise specified.

Warm up time	> 30 min.
AC supply voltage	220V± 5%, 50± 3 Hz
Ambient temperature	20°C ± 5°C
Humidity	50% ± 10%
Display mode	1366 x 768, 60 Hz, all white
e-color mode	Set to "User" mode
Contrast control	Set to The value under user mode, which allows that the brightest two of 32 linear distributed gray-scales (0 ~ 700mv) can be distinguished.
Color temperature	6500°K
Brightness control	The value under user mode
Analog Input signal	700 mVss
Picture position and size	Factory preset value,
Viewing angle	90 ° H and V
Viewing distance	40 cm for LCD performance, 20 cm for LCD failures
Ambient illumination	Dark room < 1 cd/m2

## Measurement systems

The units of measure stated in this document are listed below:

1 gamma = 1 nano tesla

1 tesla = 10,000 gauss

cm = in x 2.54

Lb = kg x 2.2

Degrees F = [°C x 1.8] + 32

Degrees C = [°F - 32]/1.8

$u' = 4x/(-2x + 12y + 3)$

$v' = 9y/(-2x + 12y + 3)$

$x = (27u'/4)/[(9u'/2) - 12v' + 9]$

$y = (3v')/[(9u'/2) - 12v' + 9]$

nits = cd/(m2) = Ft-L x 3.426

lux = foot-candle x 10.76



## LCD Monitor General Specification

LCD Panel	Driving system	TFT Color LCD
	Pixel pitch	0.3(H) x 0.3(V)
	Contrast Ratio	1000 : 1 (typ)
	Response time	5ms(Typ.). 8ms(max)
	Luminance of White	250 cd/m <sup>2</sup> (Typ.)
Input	Separate Sync.	H/V TTL
	H-Frequency	30kHz – 80kHz
	V-Frequency	55-75Hz
Viewing angle	H:170°/ V:160° ( type)(CR>10)	
Display Colors	16.7M	
Weight(with stand)	3.7KG	
Weight(without stand)	3.36KG	
Dimension(with stand)	452.59(H)x 348.90(V) x 173.80(D) (mm)	
Dimension(without stand)	452.59(H)x 288.95(V) x 60.00(D) (mm)	
Display mode	1366 x 768 @60Hz	
EPA ENERGY STAR®	ON Mode	< 37W
	OFF Mode	< 1W
Contrast control	Set to The value under user mode, which allows that the brightest two of 32 linear distributed gray-scales (0 ~ 700mv) can be distinguished.	
Power Source	100 V ~ 240 V , 50 ± 3Hz, 60 ± 3Hz	
Environmental Considerations	Operating Temp: 0° to 40°C Storage Temp: -20° to 60°C Operating Humidity: 15% to 90% Storage Humidity: 15% to 90% Operating Altitude: 12,000 feet Storage Altitude: 40,000 feet	
Peak surge current	< 55A peak at 240 VAC and cold starting	
Power line surge	No advance effects (no loss of information or defect)	

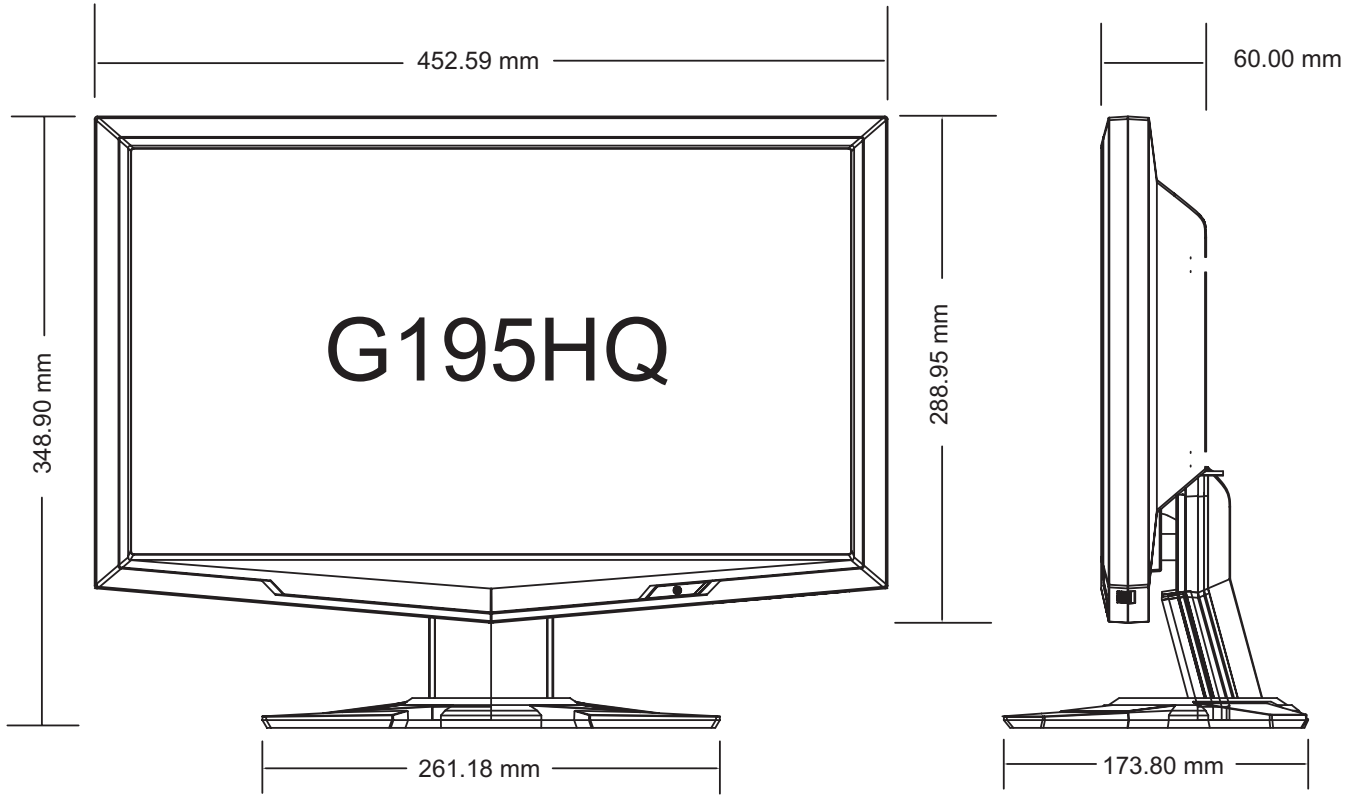

## LCD Panel Specification of G195HQ

This specification applies to the 18.5 inch-wide Color a-Si TFT-LCD Module M185XW01. The display supports the WXGA - 1366(H) x 768(V) screen format and 16.7M colors (RGB 6-bits +Hi-FRC data). All input signals are 1-channel LVDS interface and this module doesn't contain an inverter board for backlight.

### General Specifications

ITEMS	Unit	SPECIFICATIONS
Screen Diagonal	[mm]	470.1(18.51")
Active Area	[mm]	409.8 (H) x 230.4 (V)
Pixels H x V		1366(x3) x 768
Pixel Pitch	[um]	300 (per one triad) x 300
Pixel Arrangement		R.G.B. Vertical Stripe
Display Mode		TN Mode, Normally White
White Luminance ( Center )	[cd/m <sup>2</sup> ]	250 cd/m <sup>2</sup> (@ 7.5mA (Typ.))
Contrast Ratio		1000 (Typ.)
Optical Response Time	[msec]	5ms (Typ., on/off)
Nominal Input Voltage VDD	[Volt]	+5.0 V (Typ)
Power Consumption (VDD line + CCFL line)	[Watt]	17 W (Max) (without inverter, all black pattern)
Weight	[Grams]	2000 (Max)
Physical Size	[mm]	430.37 (W) x 254.6 (H) Typ. x 16.5 (D) Max
Electrical Interface		One channel LVDS
Support Color		16.7M colors (RGB 6-bit + Hi_FRC )
Surface Treatment		Glare, 3H
Temperature Range		
Operating	[°C]	0 to +50
Storage (Shipping)	[°C]	-20 to +60
RoHS Compliance		RoHS Compliance
TC0'03 Compliance		TC0'03 Compliance

### Block Diagram

TFT LCD Module

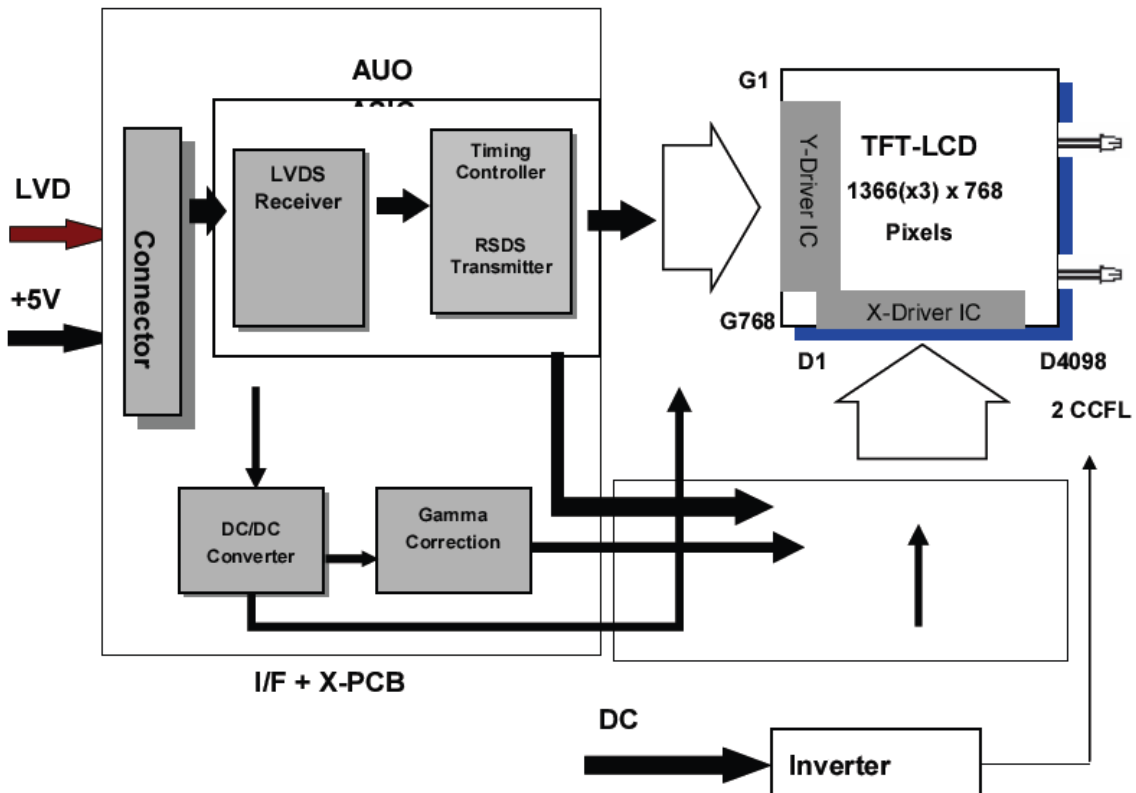

## Optical Specifications

Item	Unit	Conditions	Min.	Typ.	Max.
Viewing Angle	[degree]	Horizontal (Right) CR = 10 (Left)	150	170	-
		Vertical (Up) CR = 10 (Down)	140	160	-
Contrast ratio		Normal Direction	600	1000	-
Response Time	[msec]	Raising Time ( $T_{rR}$ )	-	3.6	5.7
		Falling Time ( $T_{rF}$ )	-	1.4	2.3
		Raising + Falling	-	5	8
Color / Chromaticity Coordinates (CIE)		Red x	0.618	0.648	0.678
		Red y	0.309	0.339	0.369
		Green x	0.262	0.292	0.322
		Green y	0.573	0.603	0.633
		Blue x	0.113	0.143	0.173
		Blue y	0.040	0.070	0.100
Color Coordinates (CIE) White		White x	0.283	0.313	0.343
		White y	0.299	0.329	0.359
Central Luminance	[cd/m <sup>2</sup> ]		200	250	-
Luminance Uniformity	[%]		75	80	-
Crosstalk (in 60Hz)	[%]				1.5
Flicker	dB				-20

## Factory Preset Timing of G195HQ

Mode	Resolution		
1	VGA	640x480	60Hz
2	VGA	640x480	72Hz
3	VGA	640x480	75Hz
4	MAC	640x480	66.66Hz
5	VESA	720x400	70Hz
6	SVGA	800x600	56Hz
7	SVGA	800x600	60Hz
8	SVGA	800x600	72Hz
9	SVGA	800x600	75Hz
10	MAC	832x624	75Hz
11	XGA	1024x768	60Hz
12	XGA	1024x768	70Hz
13	XGA	1024x768	75Hz
14	VESA	1280x720	60Hz
15	WXGA	1280x800	60Hz
16	WXGA	1366x768	60Hz

## Monitor Block Diagram

The LCD MONITOR will contain a main board, a power board, and a key board which house the flat panel control logic, brightness control logic and DDC.

The power board will provide AC to DC Inverter voltage to drive the backlight of panel and the main board chips each voltage.

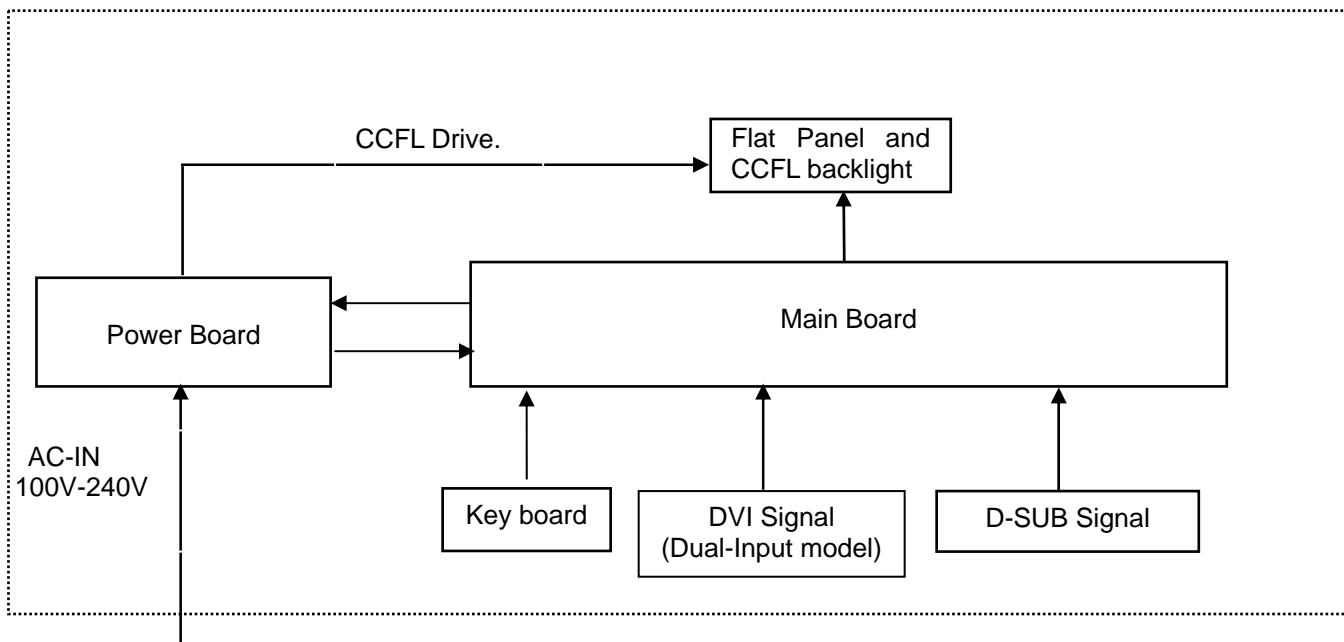

# Main Board Diagram

## T89AM6D8MXAFH2 (Dual-Input Model)

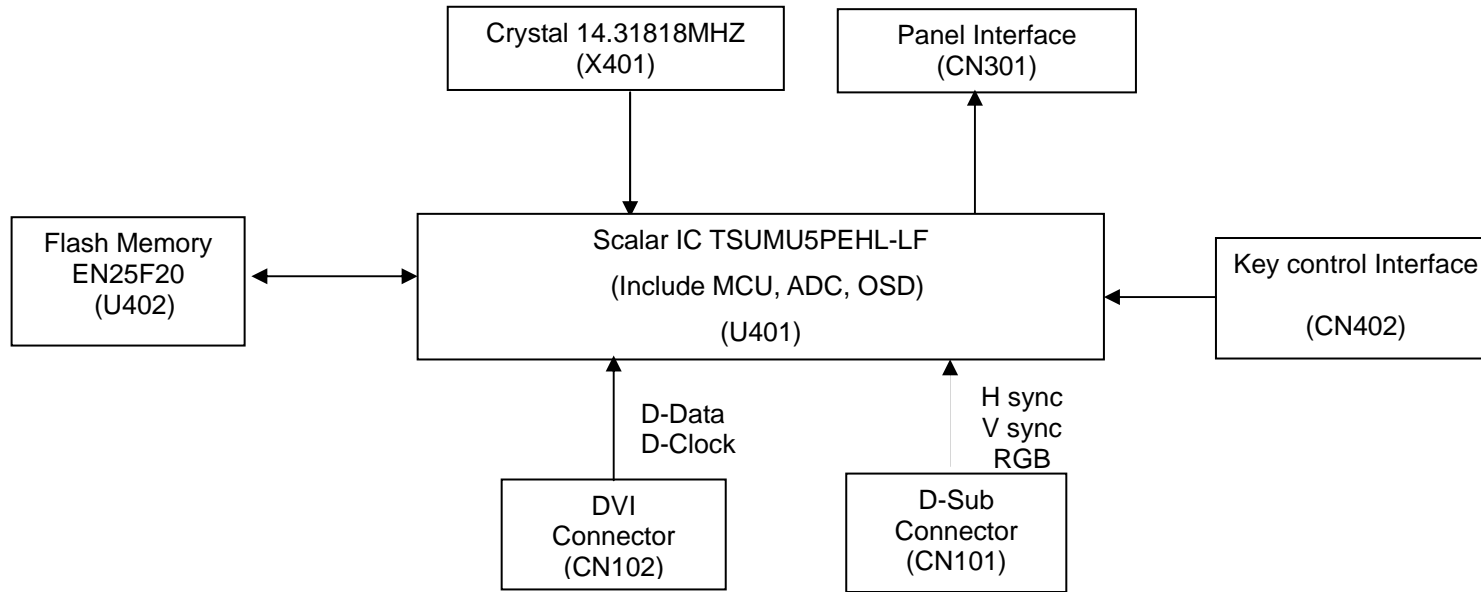

## T89AM5D8MXAFN2

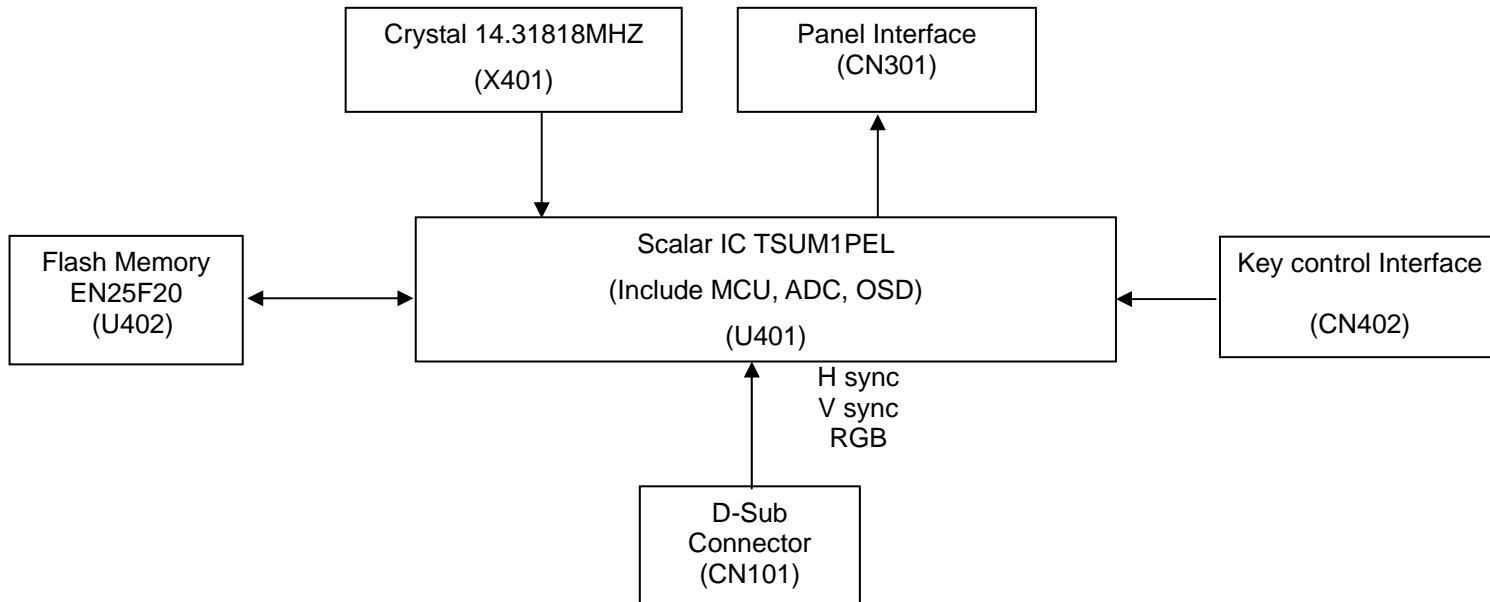

# Power Board Diagram

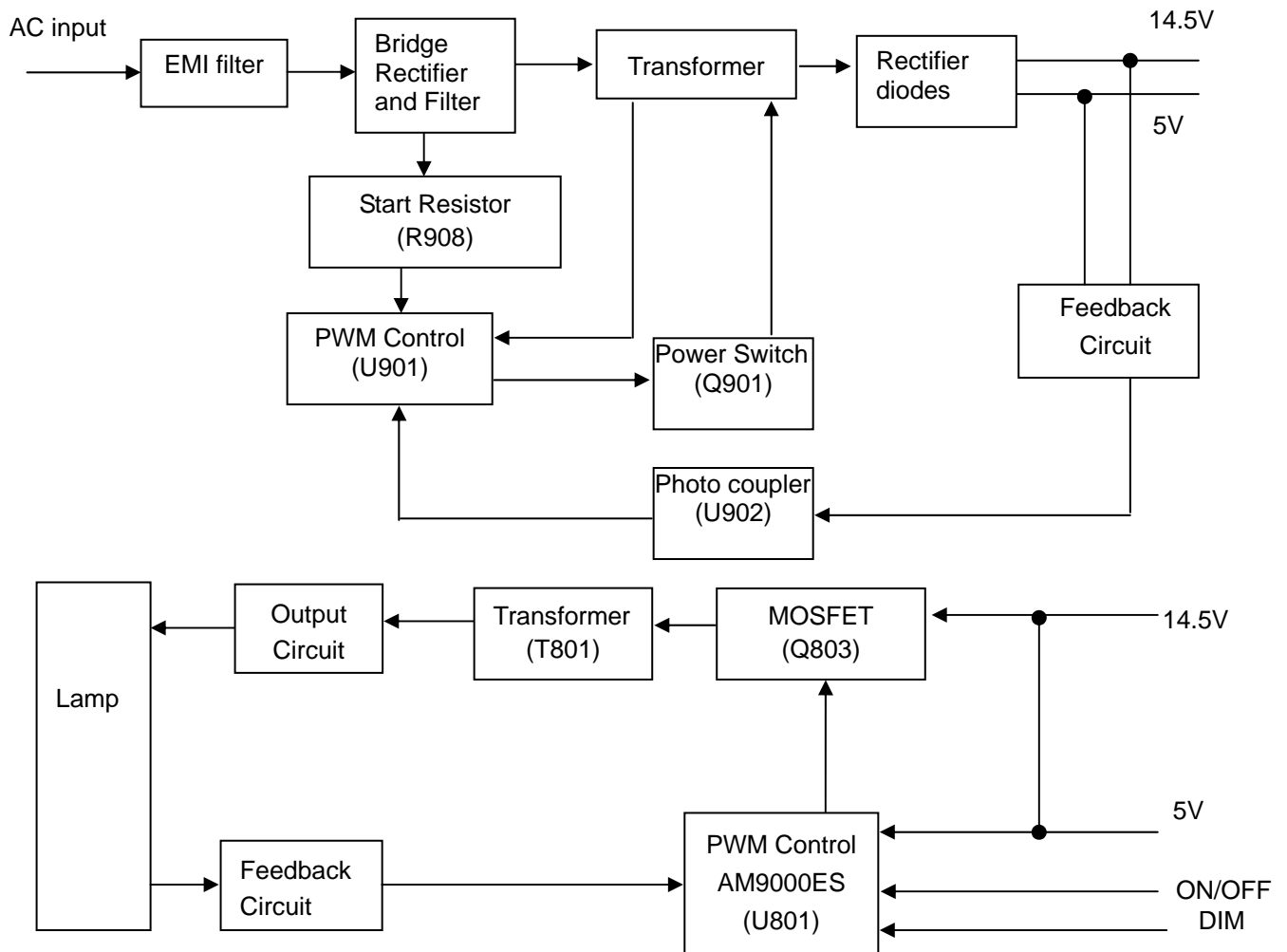



# Software Flow Chart

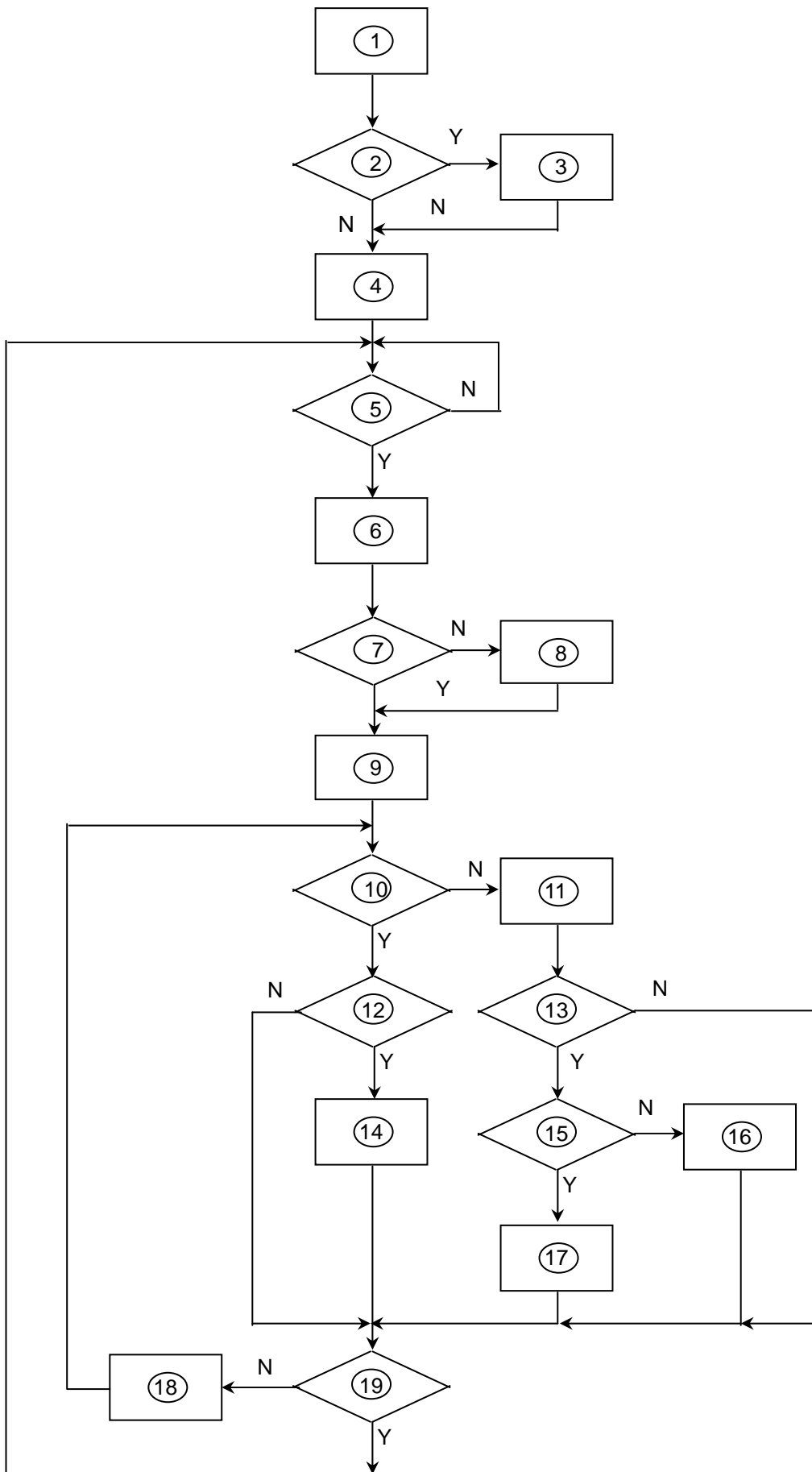

**Remark:**

1) MCU initializes.
2) Is the EEPROM blank?
3) Program the EEPROM by default values.
4) Get the PWM value of brightness from EEPROM.
5) Is the power key pressed?
6) Clear all global flags.
7) Are the AUTO and SELECT keys pressed?
8) Enter factory mode.
9) Save the power key status into EEPROM. Turn on the LED and set it to green color. Scalar initializes.
10) In standby mode?
11) Update the lifetime of back light.
12) Check the analog port, are there any signals coming?
13) Does the scalar send out an interrupt request?
14) Wake up the scalar.
15) Are there any signals coming from analog port?
16) Display "No connection Check Signal Cable" message. And go into standby mode after the message disappears.
17) Program the scalar to be able to show the coming mode.
18) Process the OSD display.
19) Read the keyboard. Is the power key pressed?

# Main Board Layout

715G2883 1 6

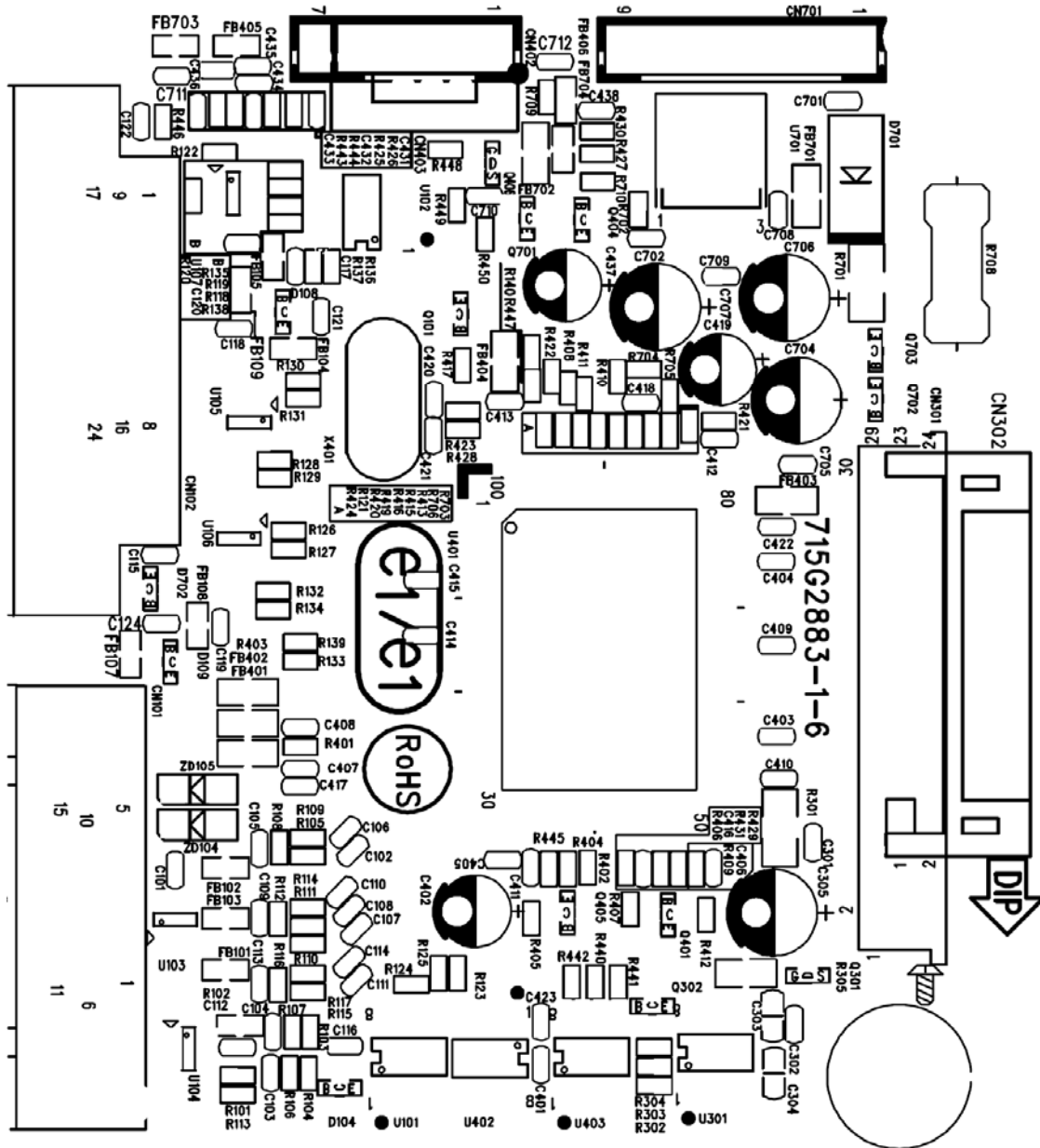

Symbol	Description	Symbol	Description
U401	TSUM1PEL PQFP-100 TSUMU5PEHL-LF PQFP-100(Dual-Input Model)	CN302	WAFER
U701	AP1117E33L-13	CN701	CONNECTOR 9P 2.0
U106	AZC099-04S SOT23-6L	CN402	CONN 6PIN 2.0
U103	AZC099-04S SOT23-6L	CN101	D-SUB 15PIN VERTICAL CONN WITH SCREW
U402	EN25F20-100GCP 2Mb SOP-8	CN102	DVI 24PIN CONN F ATTACHED SCREW(Dual-Input Model)
U104	AZC099-04S SOT23-6L	U105	AZC099-04S SOT23-6L(Dual-Input Model)
X401	14.31818MHZ/32PF/49US	U107	AZC099-04S SOT23-6L(Dual-Input Model)
U106	AZC099-04S SOT23-6L(Dual-Input Model)		

## Installation

To install the monitor to your host system, please follow the steps as given below:

### Steps

#### 1. 1-1 Connect Video Cable

- a. Make sure both the monitor and computer are powered-OFF.
- b. Connect the VGA video cable to the computer.

#### 1-2 Digital Cable (Only Dual-Input Model)

- a. Make sure both the monitor and computer are powered-OFF.
- b. Connect one end of the 24-pin DVI cable to the back of the monitor and connect the other end to the computer's port.

1-3 Connect one end of the 19-pin HDMI cable to the back of the monitor and connect the other end to the computer's port(Optional).

#### 2. Connect the Audio Cable (Only Audio-Input Model)(Optional)

#### 3. Connect power cord

Connect the power cord to the monitor, then to a properly grounded AC outlet.

#### 4. Power-ON Monitor and Computer

Power-ON the monitor first, then power-ON the computer. This sequence is very important.

5. If the monitor still does not function properly, please refer to the troubleshooting section to diagnose the problem.

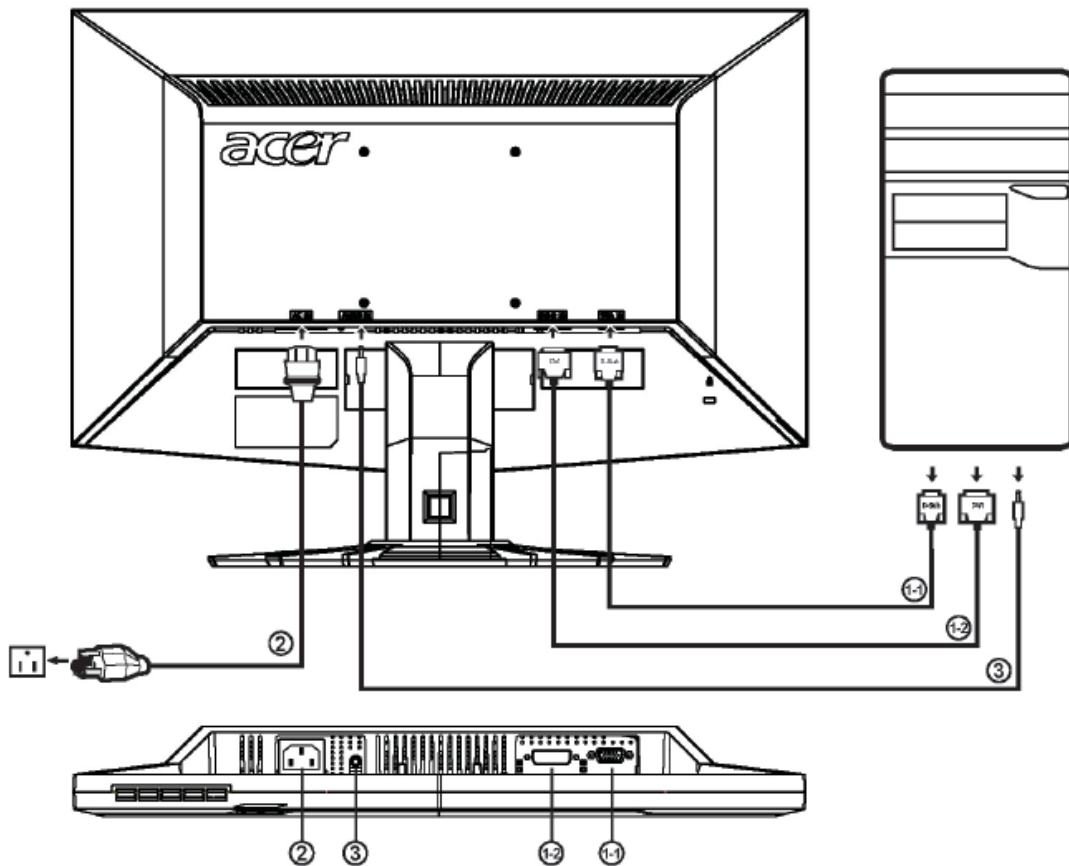

## Attaching / Removing the Base

### Attaching:

Align the base with the stand and push the base towards the top of the monitor.

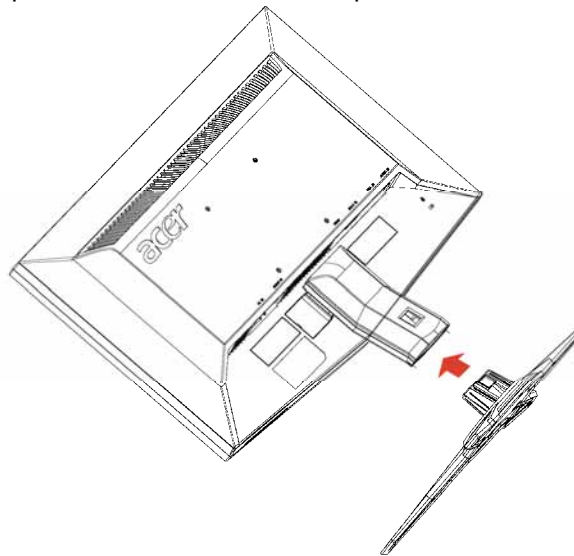

### Removing:

Depress the release hooks as indicated first before removing the base and follow the arrow direction to remove it.

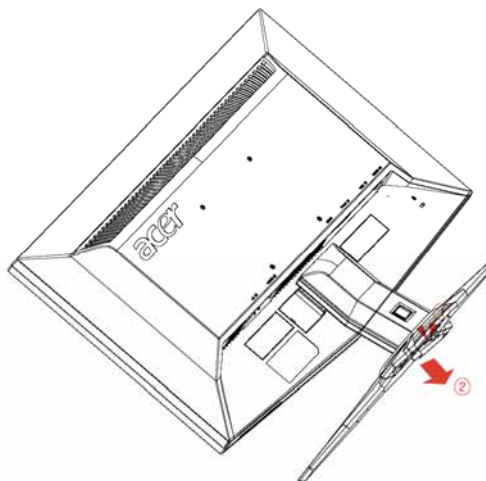

## Screen Position Adjustment

To optimize the viewing position, you can adjust the monitor tilt by using both of your hands to hold the edges of the monitor as shown below. The monitor can be adjusted to 15 degrees up or 5 degrees down.

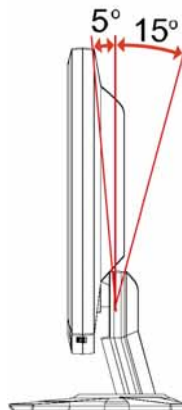

Press the power button to turn the monitor on or off. The other control buttons are located at front panel of the monitor. By changing these settings, the picture can be adjusted to your personal preferences.

- The power cord should be connected.
- Connect the video cable from the monitor to the video card.
- Press the power button to turn on the monitor position. The power indicator will light up.

## User Controls

 Power Switch / Power LED:

To turn the monitor ON or OFF.

Lights up to indicate the power is turned ON.

Using the Shortcut Menu



Press the function button to open the shortcut menu. The shortcut menu lets you quickly select the most commonly accessed settings.

 Empowering:

Press the Empowering Key to open the Acer eColor Management OSD and access the scenario modes.

**AUTO** Auto Adjust:

Press this button to activate the Auto Adjustment function. The Auto Adjustment function is used to set the HPos, VPos, Clock and Focus.

**MENU** OSD functions

Press this button to activate the OSD menu.

**Volume Up / Down**

Press to adjust volume (Only Audio-Input Model)(Optional)

**INPUT** Input Key

Use Input key to select from different video sources that may be connected to your monitor.

(a) VGA input (b) DVI input (c) HDMI input

As you cycle through the sources you will see the following messages on right top side of screen to indicate currently selected input source. It may take 1 or 2 seconds for the image to appear.

VGA or DVI or HDMI

If either VGA or DVI input is selected ,but the VGA and DVI cables are not connected, a floating dialog box indicates: "No Cable Connect" or "No Signal"

## eColor Management (OSD)



### Operation instructions

Step 1: Press “**e**” Key to open the Acer eColor Management OSD and access the scenario modes

Step 2: Press “◀” or “▶” to select the mode

Step 3: Press “AUTO” Key to confirm the mode and exit the eColor menu.

### Features and Benefits

Main Menu icon	Sub Menu icon	Sub Menu item	Description
	N/A	User mode	User defined. Settings can be fine-tuned to suit any situation
	N/A	Text mode	Optimal balance of brightness and contrast prevent eyestrain. The most comfortable way to read onscreen text
	N/A	Standard mode	Default Setting. Reflects native display capability
	N/A	Graphic mode	Enhances colors and emphasize fine detail. Pictures and photographs appear in vibrant colors with sharp detail.
	N/A	Movie mode	Displays scenes in clearest detail. Presents great visuals, even in unsuitably-lit environments.

### Adjusting the OSD settings

The OSD can be used for adjusting the settings of your LCD Monitor. Press the MENU key to open the OSD. You can use the OSD to adjust the picture quality, OSD position and general settings. For advanced settings, please refer to following page:

#### Adjusting the picture quality



1 Press the MENU key to bring up the OSD.

2 Using the ◀/▶ keys, select  Picture from the OSD. Then navigate to the picture element you wish to adjust.

3 Use the ◀/▶/ keys to adjust the sliding scales.

4 The Picture menu can be used to adjust the current Brightness, Contrast, Colour Temp, Auto Config and other image-related qualities.

Adjusting the OSD position



1 Press the MENU key to bring up the OSD.

2 Using the directional  keys, select OSD from the on screen display. Then navigate to the feature you wish to adjust.

Adjusting the setting



1 Press the MENU key to bring up the OSD.

2 Using the ◀/▶ keys, select  Setting from the OSD. Then navigate to the feature you wish to adjust.

3 The Setting menu can be used to adjust the screen Menu Language and other important settings.



## Product information



1 Press the MENU key to bring up the OSD.

2 Using the ◀/▶ keys, select  Information from the OSD. Then the basic information of LCD monitor will show up for current input.

## **How to Optimize The DOS-Mode**

### **Plug And Play**

#### **Plug & Play DDC2B Feature**

This monitor is equipped with VESA DDC2B capabilities according to the VESA DDC STANDARD. It allows the monitor to inform the host system of its identity and, depending on the level of DDC used, communicate additional information about its display capabilities.

The DDC2B is a bi-directional data channel based on the I<sup>2</sup>C protocol. The host can request EDID information over the DDC2B channel.

**This monitor will appear to be non-functional if there is no video input signal. In order for this monitor to operate properly, there must be a video input signal.**

This monitor meets the Green monitor standards as set by the Video Electronics Standards Association (VESA) and/or the United States Environmental Protection Agency (EPA) and The Swedish Confederation Employees (NUTEK). This feature is designed to conserve electrical energy by reducing power consumption when there is no video-input signal present. When there is no video input signals this monitor, following a time-out period, will automatically switch to an OFF mode. This reduces the monitor's internal power supply consumption. After the video input signal is restored, full power is restored and the display is automatically redrawn. The appearance is similar to a "Screen Saver" feature except the display is completely off. Pressing a key on the keyboard, or clicking the mouse restores the display.

### **Using the Right Power Cord**

The accessory power cord for the Northern American region is the wallet plug with NEMA 5-15 style and is UL listed and CSA labeled. The voltage rating for the power cord shall be 125 volts AC.

Supplied with units intended for connection to power outlet of personal computer: Please use a cord set consisting of a minimum No. 18 AWG, type SJT or SVT three conductors flexible cord. One end terminates with a grounding type attachment plug, rated 10A, 250V, and CEE-22 male configuration. The other end terminates with a molded-on type connector body, rated 10A, 250V, having standard CEE-22 female configuration.

Please note that power supply cord needs to use VDE 0602, 0625, 0821 approval power cord in European countries.

### **Enter into the factory mode:**

Turn off the power, press the "e-color" and turn the power on. The factory OSD will be at the left top of the panel.

This chapter contains step-by-step procedures on how to disassemble the monitor-G195HQ for maintenance.

The tool for disassembly is as follows:

Screwdriver, Hexagonal screwdriver, Putty knife.

### Disassembly Procedure

1. Lay the monitor on a flat, soft and clean surface.



2. Press the button remarked in green the remove the base.



3. Remove the two piece of cover hinge and the four screws remarked in red to remove the hinge assembly.



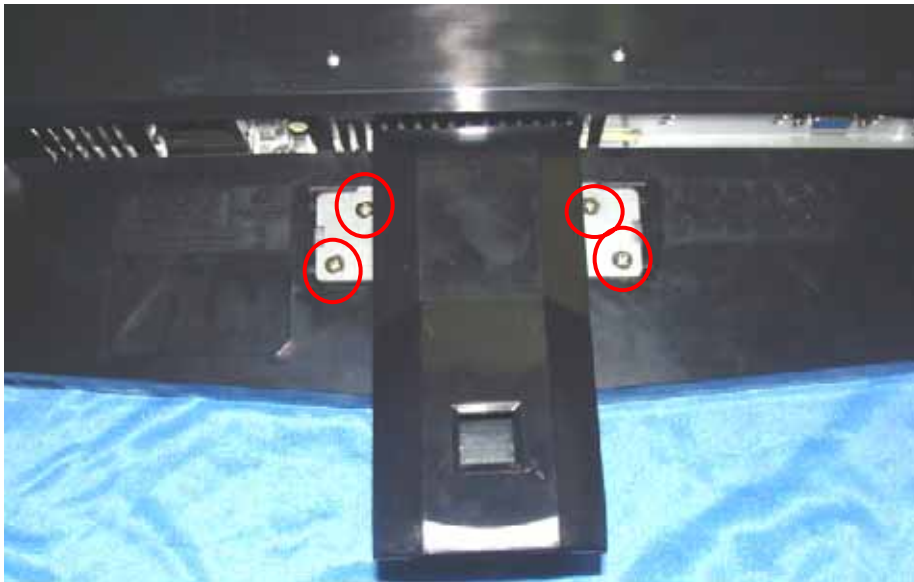

4.Remove the rear cover.

Pry the monitor up then find out the hooks' position, use the tool (like the picture or other card) to insert into the gap of bezel and rear cover.





Turn over the monitor and take off the rear cover.



4. Remove the bezel.

Disconnect the connector remarked in green.

PS: be careful to Disconnect the Key board connector, because the keyboard connector maybe damage.

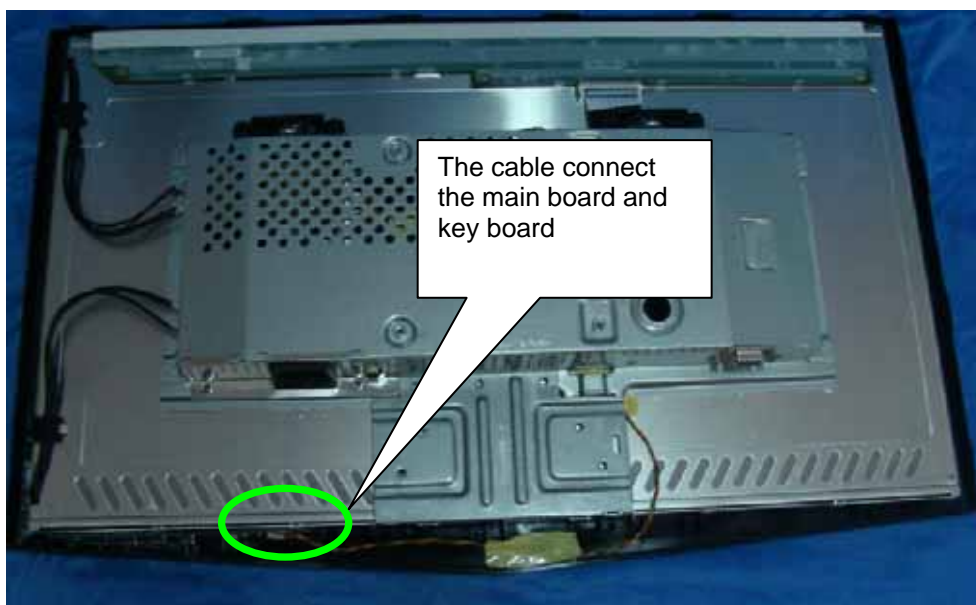

Remove the 2 screws remarked in red.

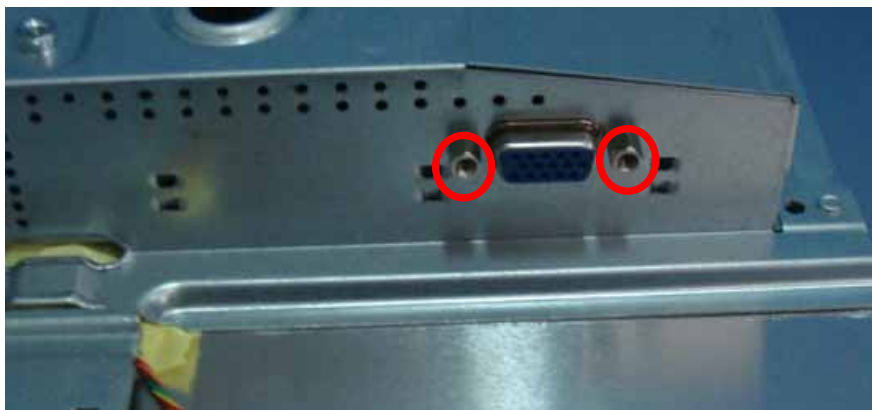

Remove the lamp connectors to remove the panel. Put attention to the LVDS cable.

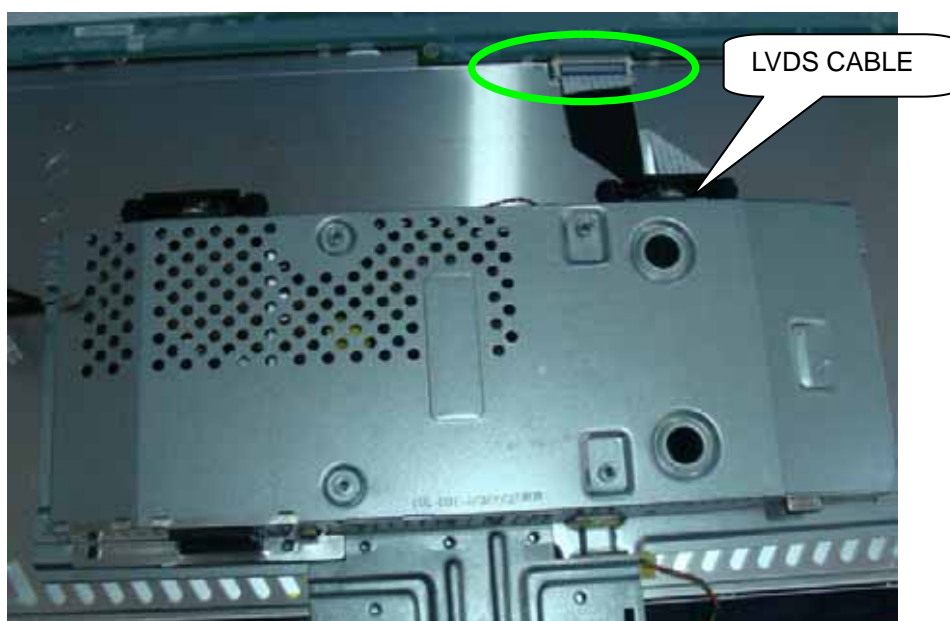



6. Turn over the main frame and remove the four screws remarked in red and disconnected remarked in green to remove the main board and power board.

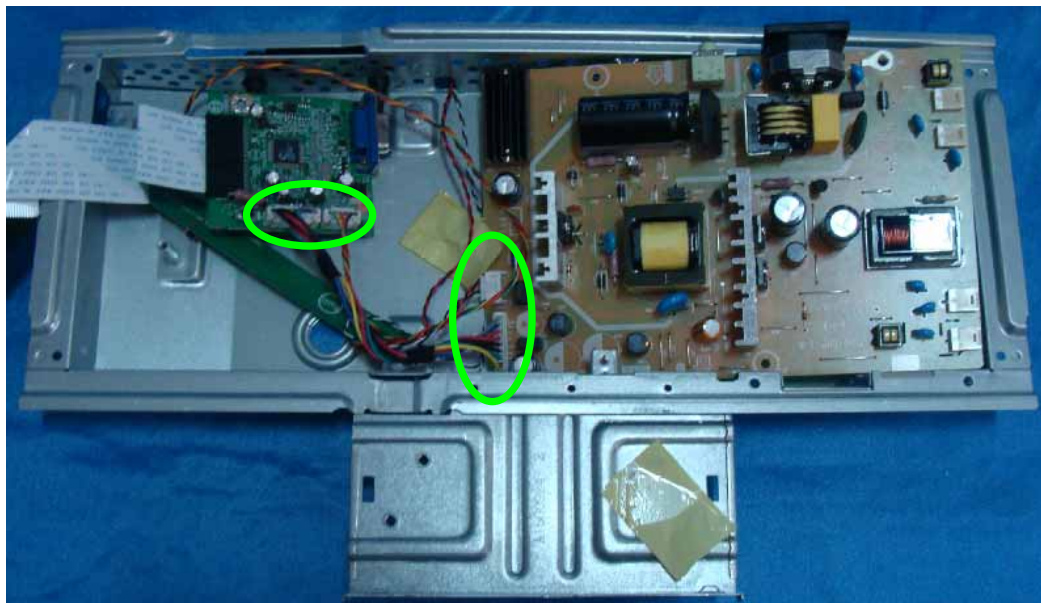
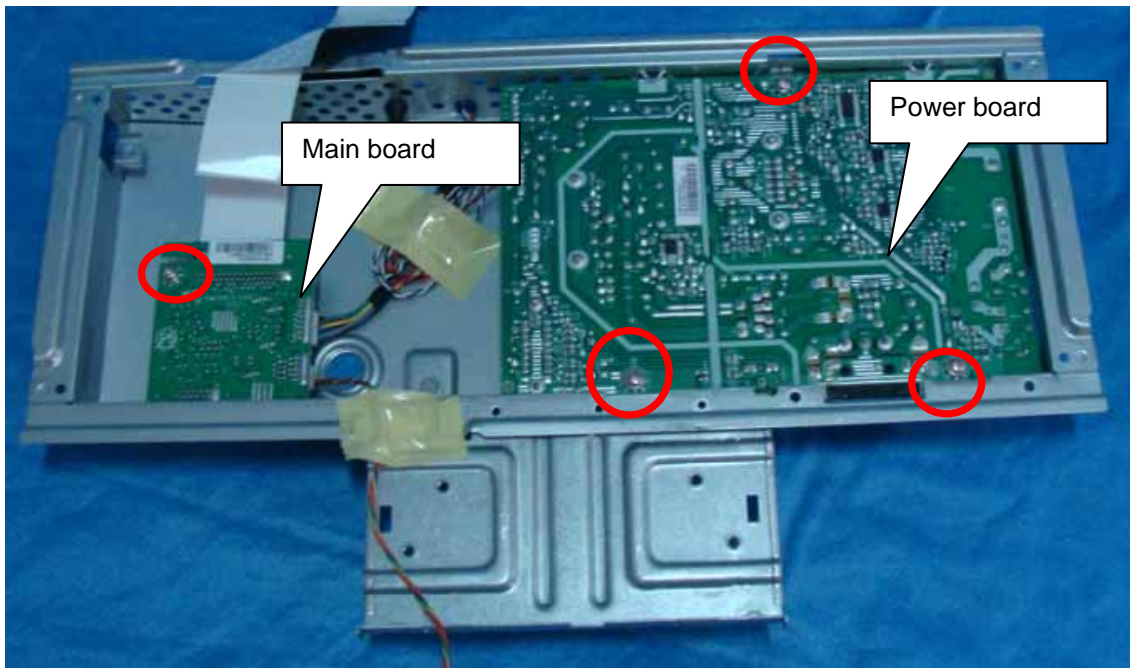

Remove the speakers.(Optional)

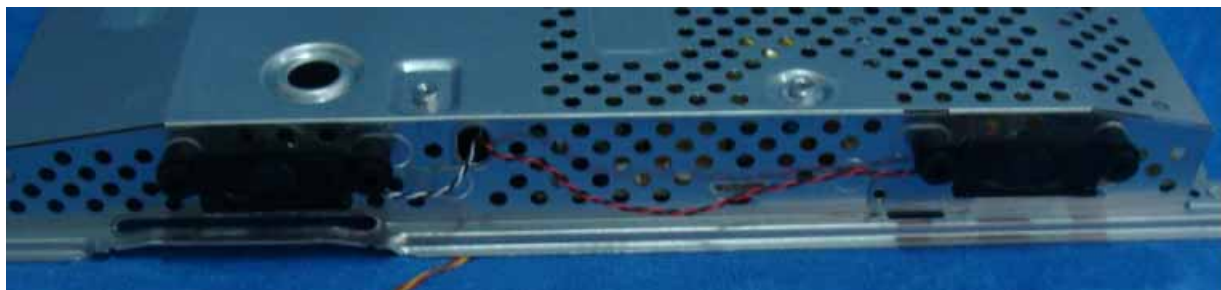

7.The panel





This chapter provides troubleshooting information for the G195HQ:

1.Main Board

1) No Power

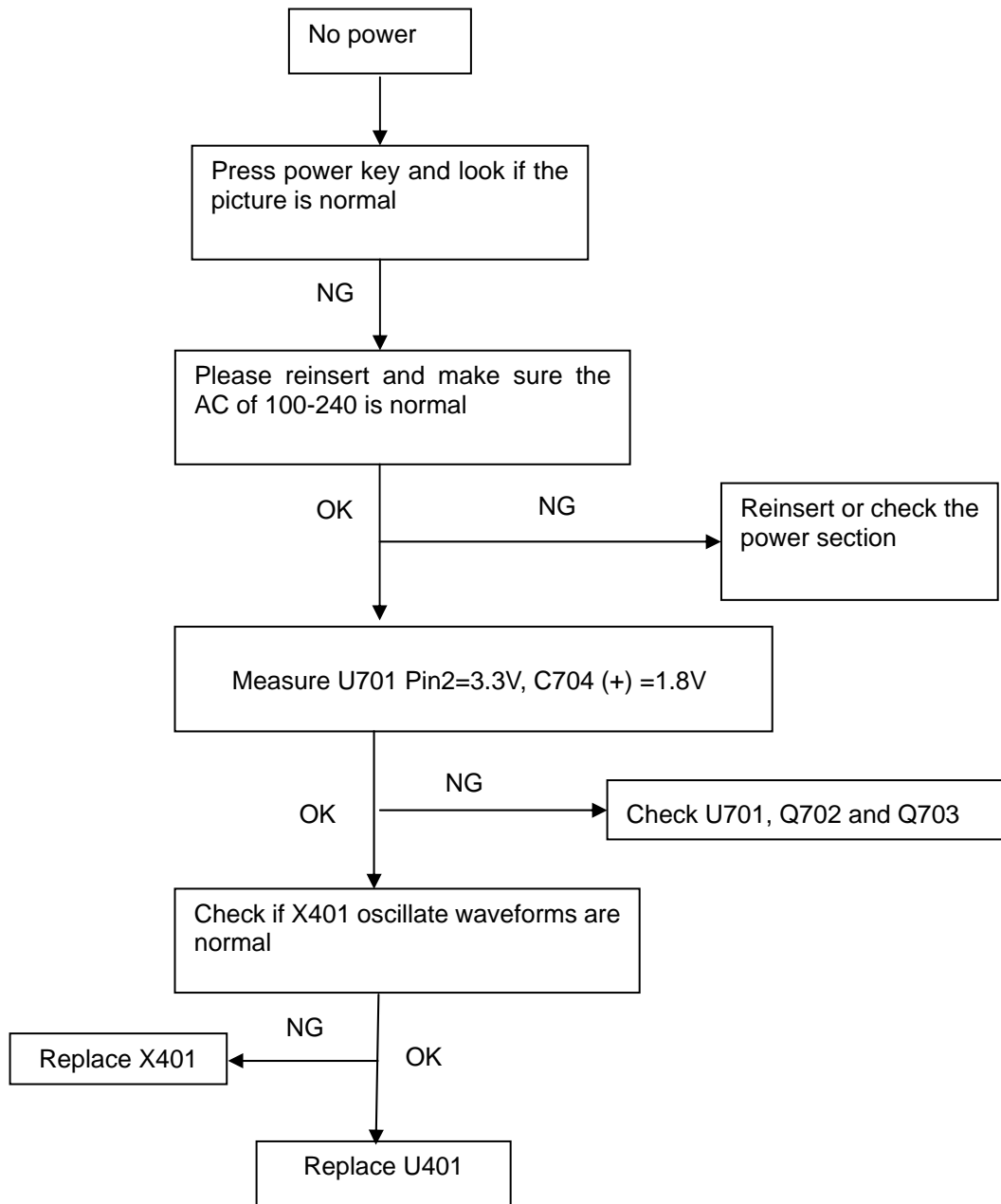

## 2) No Picture (LED is orange)

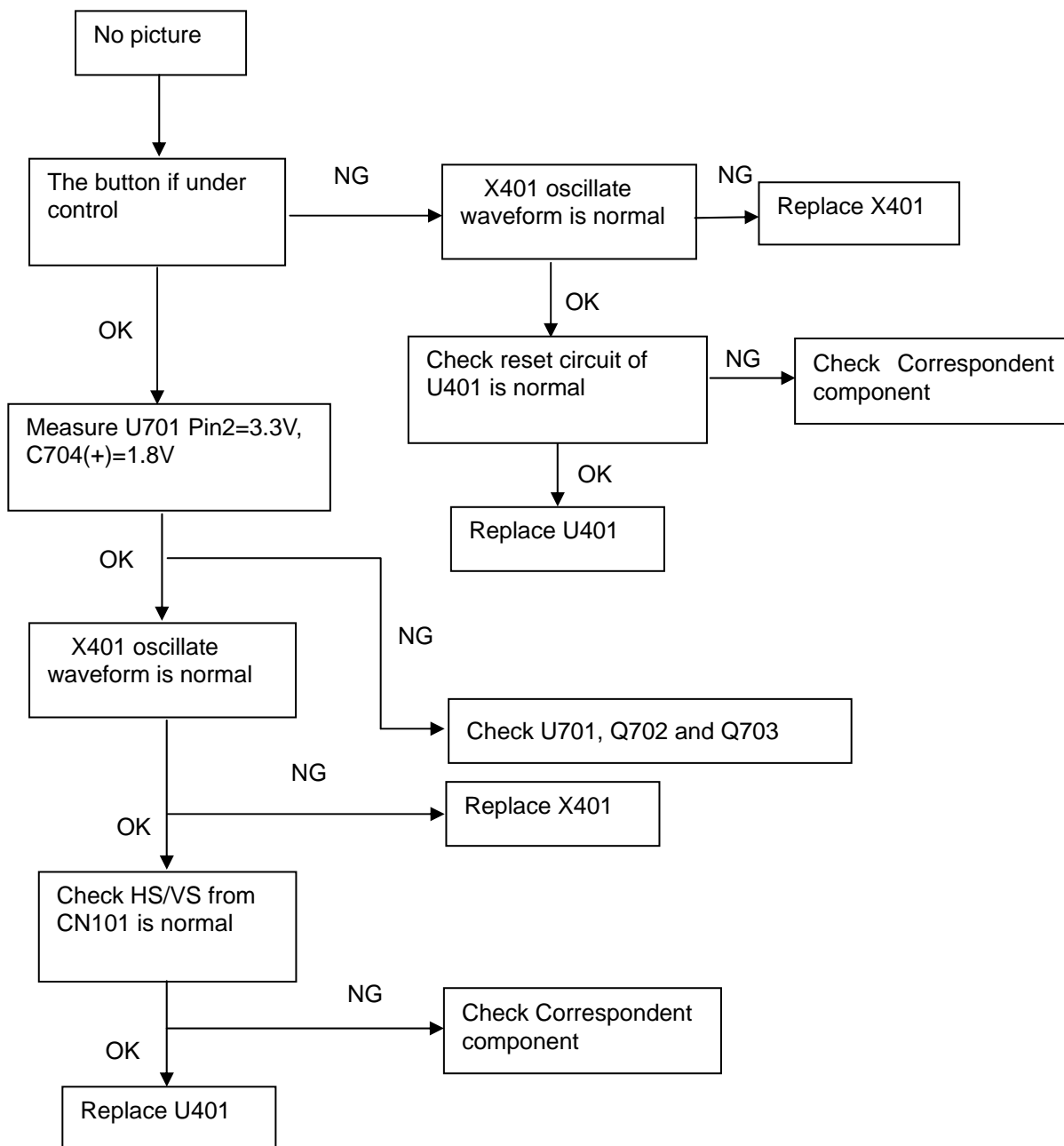

### 3) Panel Power Circuit

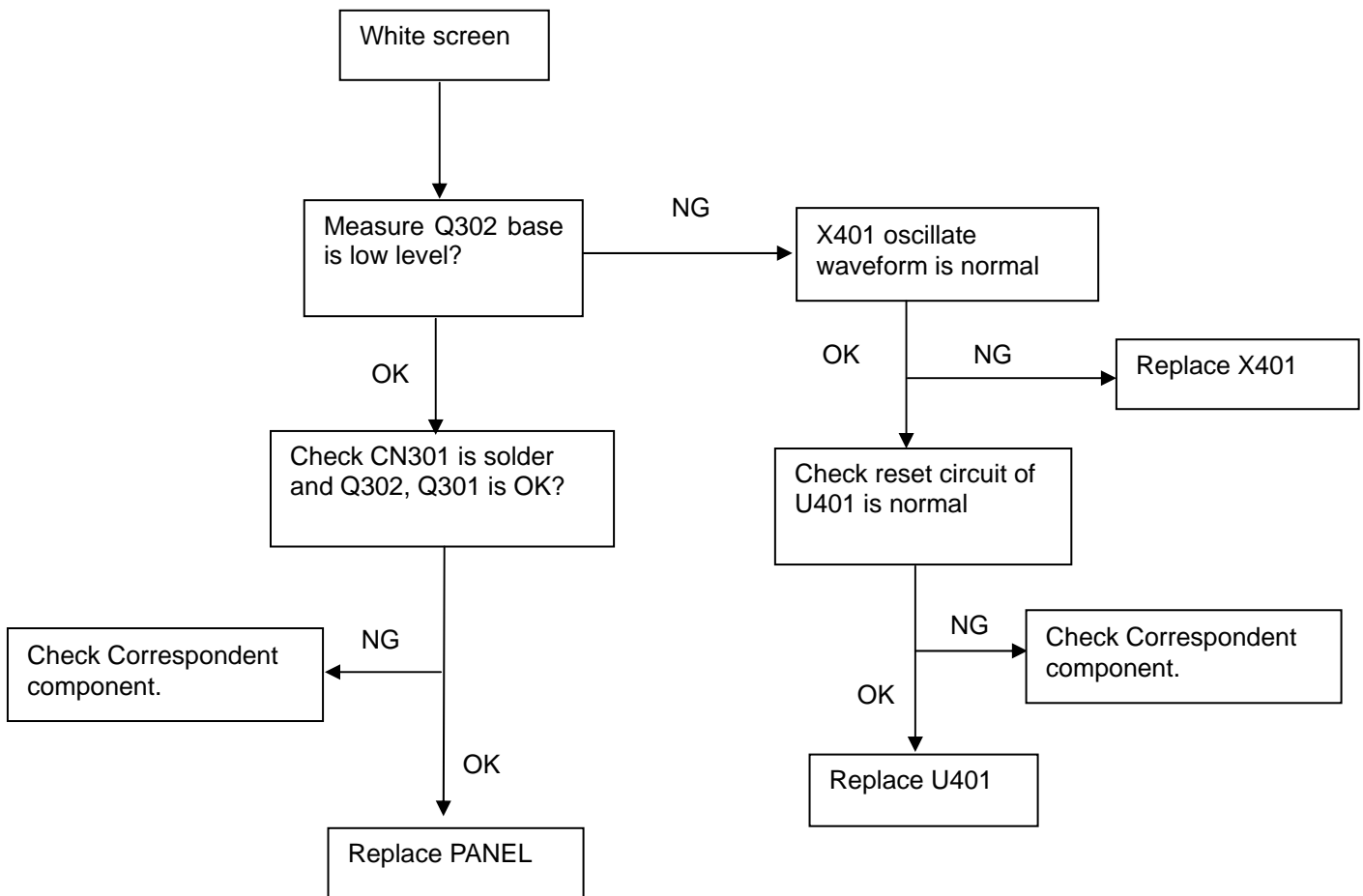

## 2. Key Board

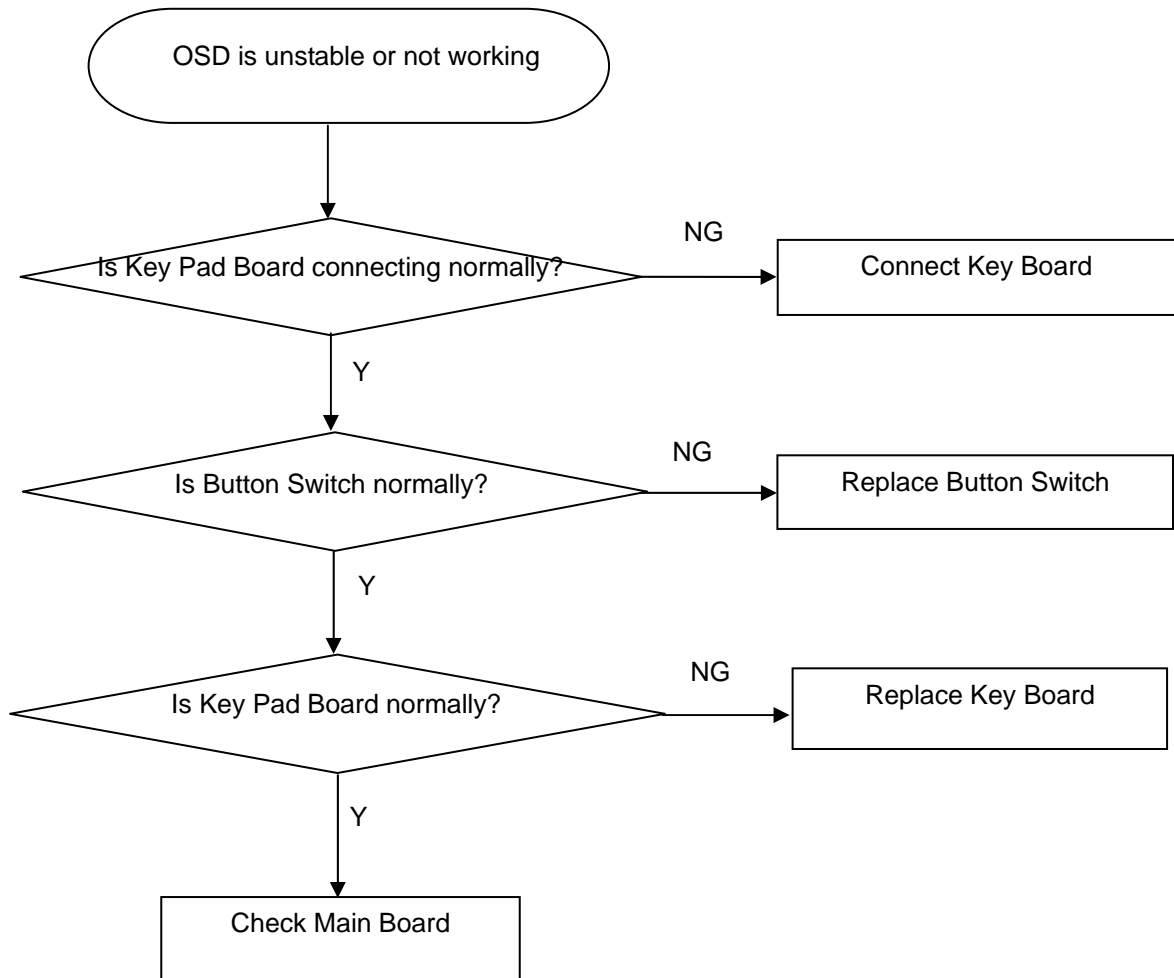

### 3. Power Board

#### 1) No power

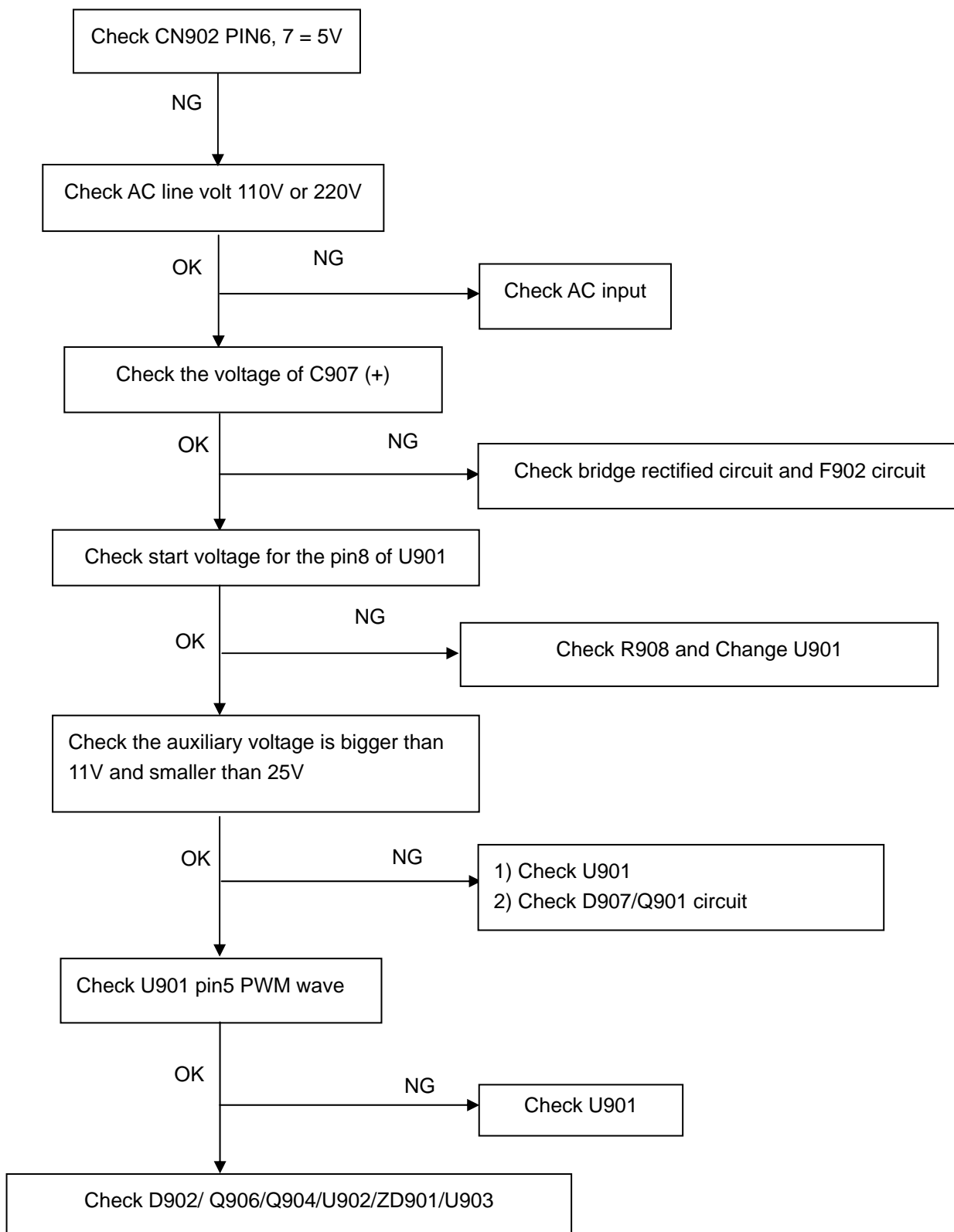

## 2.) No Backlight

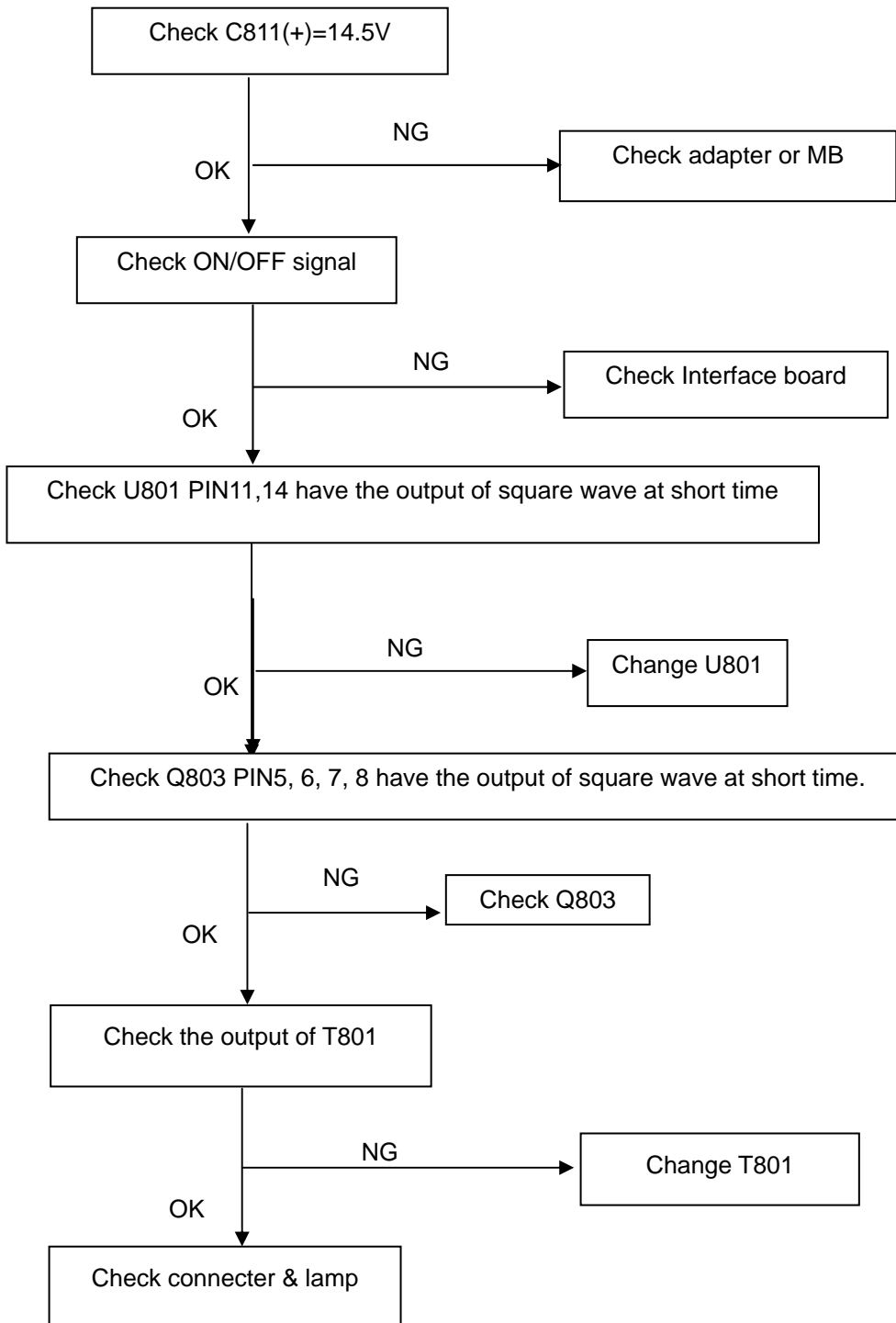

D-sub connect and DVI connect:

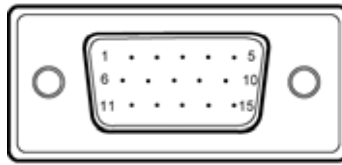

15-Pin Color Display Signal Cable

PIN NO.	DESCRIPTION	PIN NO.	DESCRIPTION
1.	Red	9.	+5V
2.	Green	10.	Logic Ground
3.	Blue	11.	Monitor Ground
4.	Monitor Ground	12.	DDC-Serial Data
5.	DDC-return	13.	H-Sync
6.	R-Ground	14.	V-Sync
7.	G-Ground	15.	DDC-Serial Clock
8.	B-Ground		

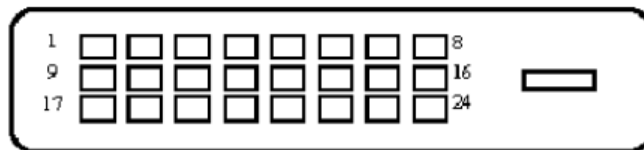

24-Pin Color Display Signal Cable (Dual-Input Model)

PIN	Meaning	PIN	Meaning
1.	TMDS Data2-	13.	NC
2.	TMDS Data2+	14.	+5V Power
3.	TMDS Data 2/4 Shield	15.	Logic Ground
4.	NC	16.	Hot Plug Detect
5.	NC	17.	TMDS Data0-
6.	DDC Clock	18.	TMDS Data0+
7.	DDC Data	19.	TMDS Data 0/5 Shield
8.	NC	20.	NC
9.	TMDS Data1-	21.	NC
10.	TMDS Data1+	22.	TMDS Clock Shield
11.	TMDS Data 1/3 Shield	23.	TMDS Clock+
12.	NC	24.	DDC TMDS Clock-

This chapter gives you the FRU (Field Replaceable Unit) listing in global configurations of G195HQ. Refer to this chapter whenever ordering for parts to repair or for RMA (Return Merchandise Authorization).

**NOTE:** Please note WHEN ORDERING FRU PARTS, that you should check the most up-to-date information available on your regional web or channel (<http://aicsl.acer.com.tw/spl/>). For whatever reasons a part number change is made, it will not be noted in the printed Service Guide. For ACER AUTHORIZED SERVICE PROVIDERS, your Acer office may have a DIFFERENT part number code from those given in the FRU list of this printed Service Guide. You MUST use the local FRU list provided by your regional Acer office to order FRU parts for repair and service of customer machines.

**NOTE:** To scrap or to return the defective parts, you should follow the local government ordinance or regulations on how to dispose it properly, or follow the rules set by your regional Acer office on how to return it.

## Exploded Diagram (Model: G195HQ)

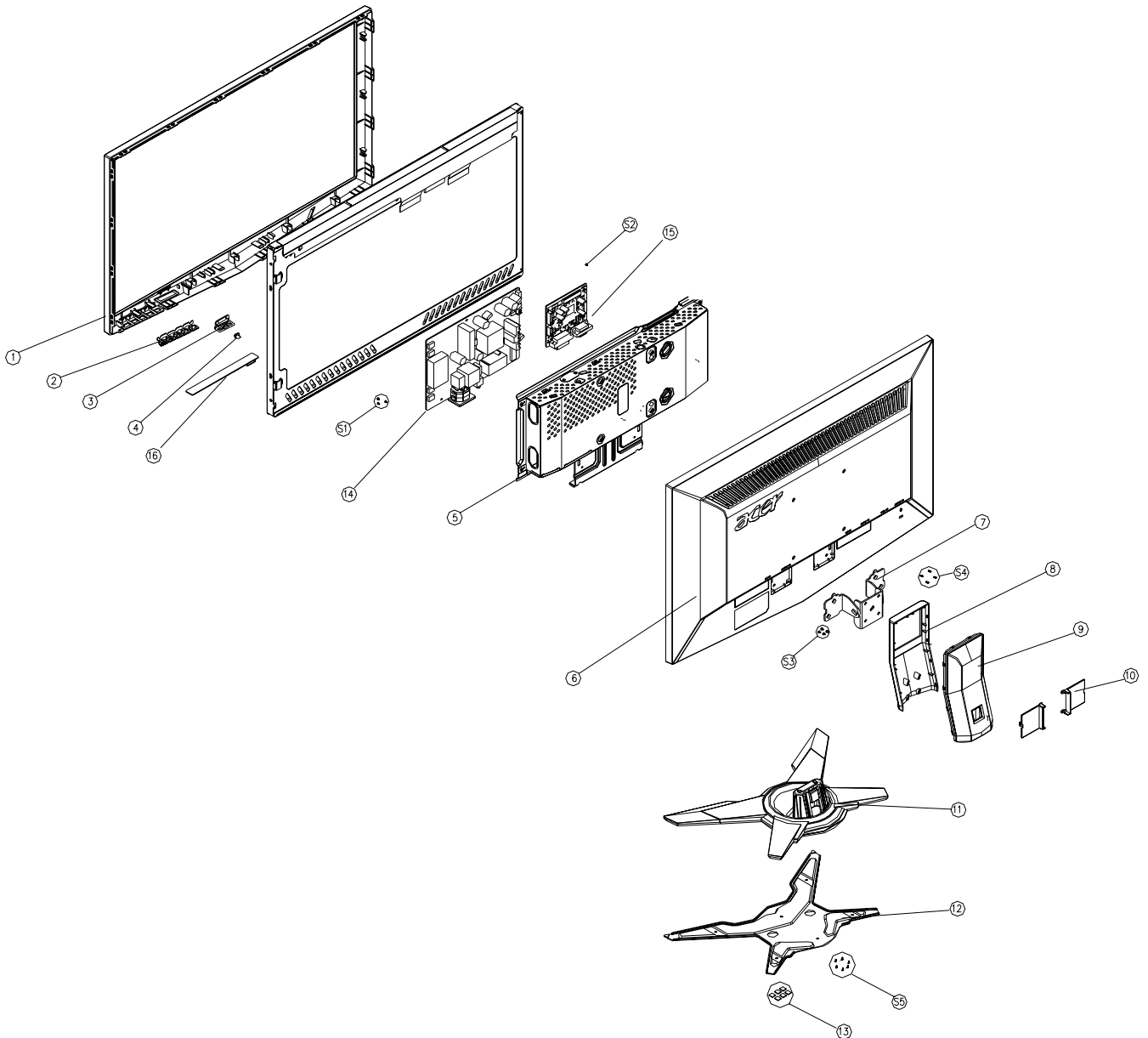



Item	Description	TPV Part No.	Acer Part No.	Q`ty
1	BEZEL L185WA-9acer5	A34G1522AEMA1B0130	60.LJM0B.001	1
2	KEY BUTTON	A33G0779AEM 1L0100	N/A	1
3	POWER BUTTON	A33G0780AEM 1L0100	N/A	1
4	LENS	A33G0768 1 1C0100	N/A	1
5	MAINFRAME	A15G0933101401 A15G0933101301 (Dual-Input Model)	60.LJM0B.008 60.LJM0B.009 (Dual-Input Model)	1
6	REAR COVER L205WA-9ACER5-S5	A34G1523AEM 4B0100 A34G1523AEM 3B0100 (Dual-Input Model)	60.LJM0B.002 60.LJM0B.003 (Dual-Input Model)	1
7	HINGE	A37G0137 1	60.LJM0B.004	1
8	STAND FRONT	A34G1524AEM 1B0100	60.LJM0B.005	1
9	STAND REAR	A34G1525AEM 1B0100	60.LJM0B.006	1
10	HINGE COVER	A33G0772AEM 1L0100	60.LJO0B.004	2
11	BASE	A34G1521AEM 1B0100	60.LJM0B.007	1
12	BRACKET BASE	A15G0932101	N/A	1
13	RUBBER	Q12G6300 95	N/A	6
14	POWER BOARD	PWPC9821AQMY	55.LJM0B.003	1
15	MAIN BOARD	756GQ9CB BA256 00 756GQ9CB BA255 00 (Dual-Input Model)	55.LJM0B.001 55.LJM0B.002 (Dual-Input Model)	1
16	KEY BOARD	KEPC9QKO	55.LJO0B.002	1
S1	SCREW(FOR PB/MAIN FRAME)	0G1G1130 8120	N/A	3
S2	SCREW,(FOR MB/MAIN FRAME)	0G1G1130 8120	N/A	1
S3	SCREW(FOR HINGE/REAR COVER)	0Q1G1740 12120	N/A	4
S4	SCREW	0M1G 140 6125	N/A	4
S5	SCREW (T3X6)	0Q1G 130 6120	N/A	6

**Part List**

Above picture show the description of the following component.

Picture	Description	TPV Part No.	Acer Part No.
	Main_frame	A15G0933101401 A15G0933101301 (Dual-Input Model)	60.LJM0B.008 60.LJM0B.009 (Dual-Input Model)
	Bezel	A34G1522AEMA1B0130	60.LJM0B.001
	Panel	750GLU185X1414N000	LK.18005.016
	Rear Cover	A34G1523AEM 4B0100 A34G1523AEM 3B0100 (Dual-Input Model)	60.LJM0B.002 60.LJM0B.003 (Dual-Input Model)
	Power Board	PWPC9821AQMY	55.LJM0B.003

	Main Board	756GQ9CB BA256 00 756GQ9CB BA255 00 (Dual-Input Model)	55.LJM0B.001 55.LJM0B.002 (Dual-Input Model)
	Key Board	KEPC9QKO	55.LJO0B.002
	Hinge	A37G0137 1	60.LJM0B.004
	Base	A34G1521AEM 1B0100	60.LJM0B.007
	Bracket Base	A15G0932101	N/A
	LVDS ASS'Y	095G8018 3XH60	50.LEF0B.002

	D-SUB Cable	089G 728CAA DB	50.LAL0B.002
	DVI Cable (Dual-Input Model)	089G1748HAA AC	50.LAN0B.003
	Power Cord	089G404A18N CX	50.LBT0B.004

## Main Board

### T89AM6D8MXAFH2 (Dual-Input Model)

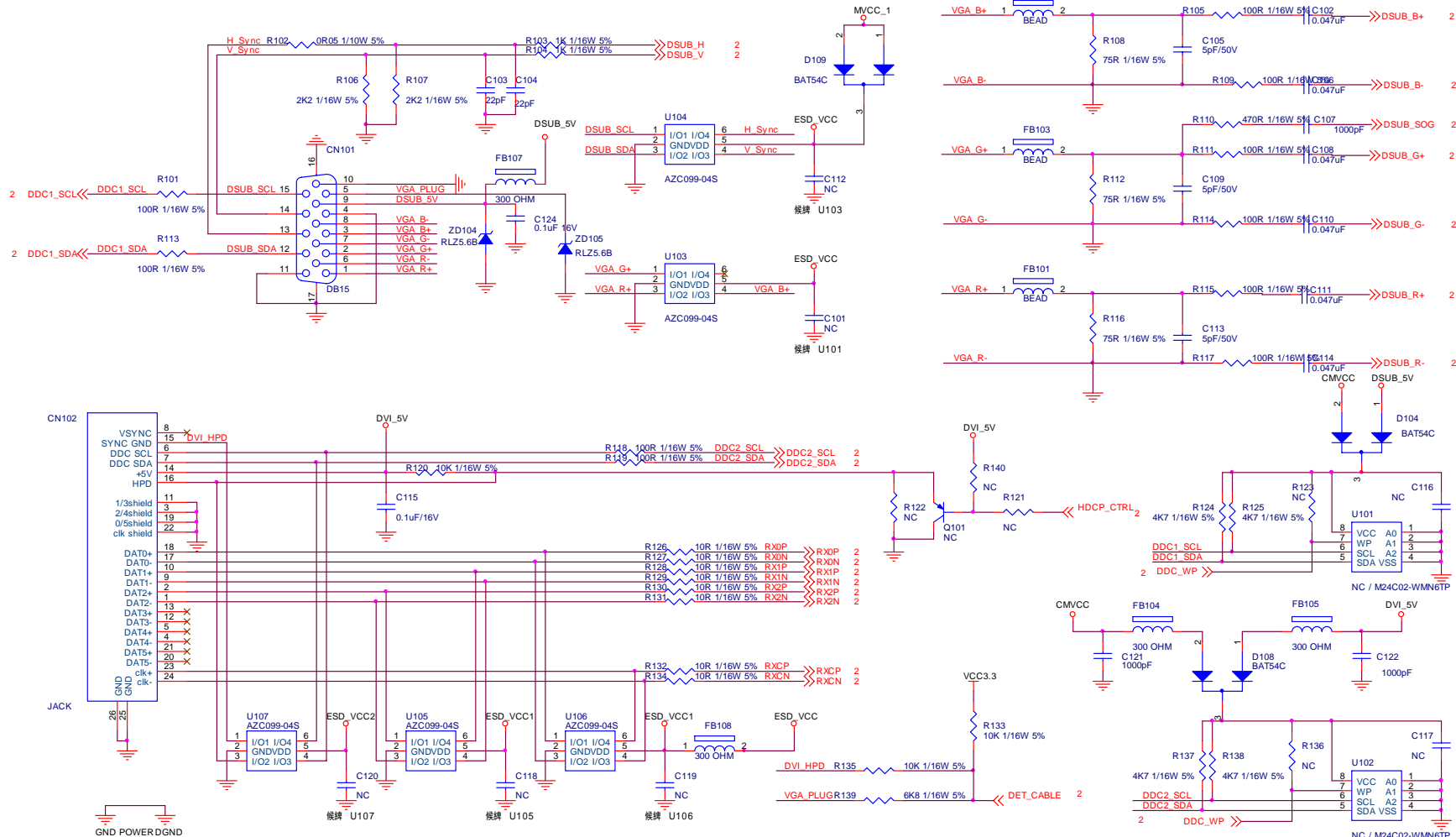

T P V ( Top Victory Electronics Co., Ltd. )	OEM MODEL	Acer G185H Dual Only		Size	B
规格书编号	G2883-1-6-X37-090901	TPV MODEL	CBPC9M6AFQH	Rev	E
Key Component	2.0.INPUT	PCB NAME		称	<称>
Date	Tuesday, September 01, 2009	Sheet	2 of 6		

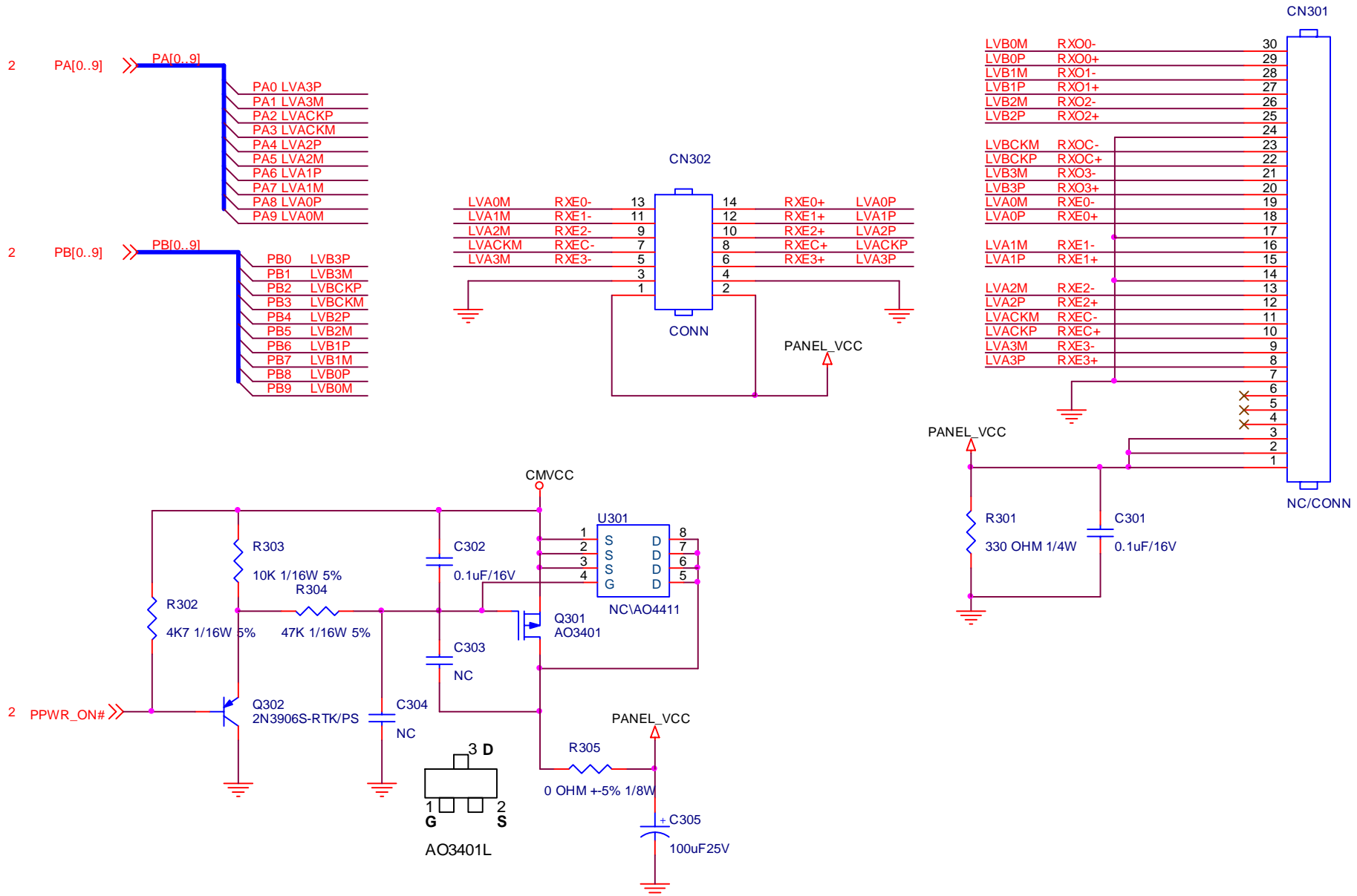

TPV (Top Victory Electronics Co., Ltd.)	OEM MODEL	Acer G185H Dual Only	Size	A	
結 隔 瓜 細 膜	G2883-1-6-X-37-090901	TPV MODEL	CBPC9M6AFQH	Rev	E
Key Component	3.0.OUTPUT	PCB NAME		稱 爹	<稱爹>
Date	Tuesday, September 01, 2009	Sheet	3 of 6		

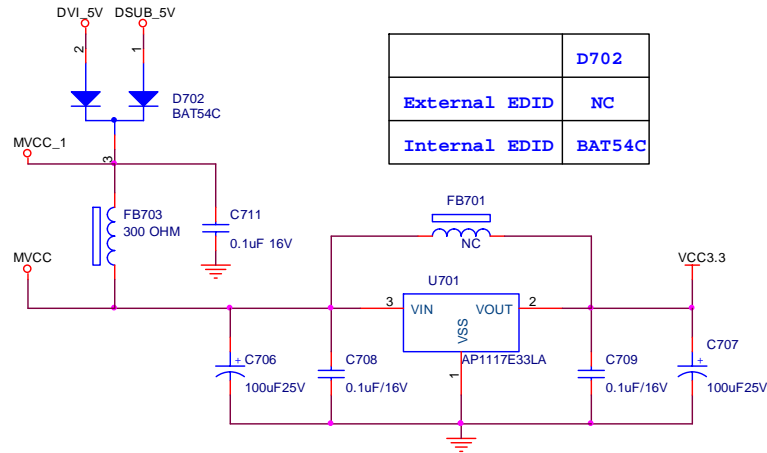
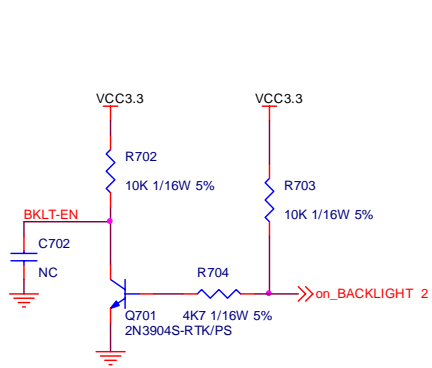
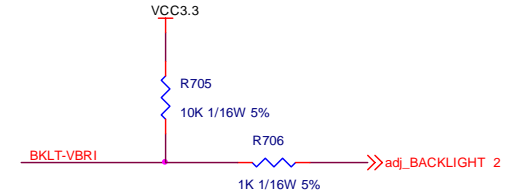
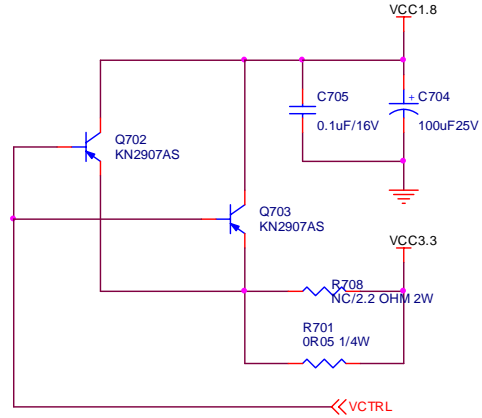
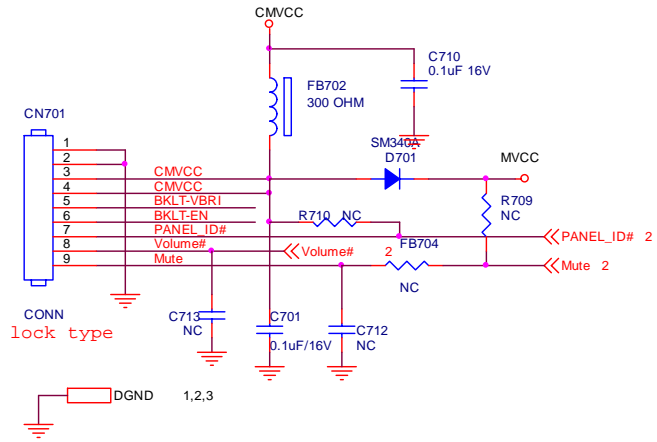

	D702
External EDID	NC
Internal EDID	BAT54C

	R701	R708	U701
TSUM5PFHL	0R05 1/4W	NC	223
TSUM58EHL	NC	3.3 OHM 2W	223
TSUM58CWHL	NC	3.3 OHM 2W	252

TPV (Top Victory Electronics Co., Ltd.)	OEM MODEL	Acer G185H Dual Only		Size	B
絲瓜 編腰	G2883-1-6-X-37-090901	TPV MODEL	CBPC9M6AFQH	Rev	E
Key Component	4.0.POWER	PCB NAME		稱號	<稱號>
Date	Tuesday, September 01, 2009	Sheet	4 of 6		

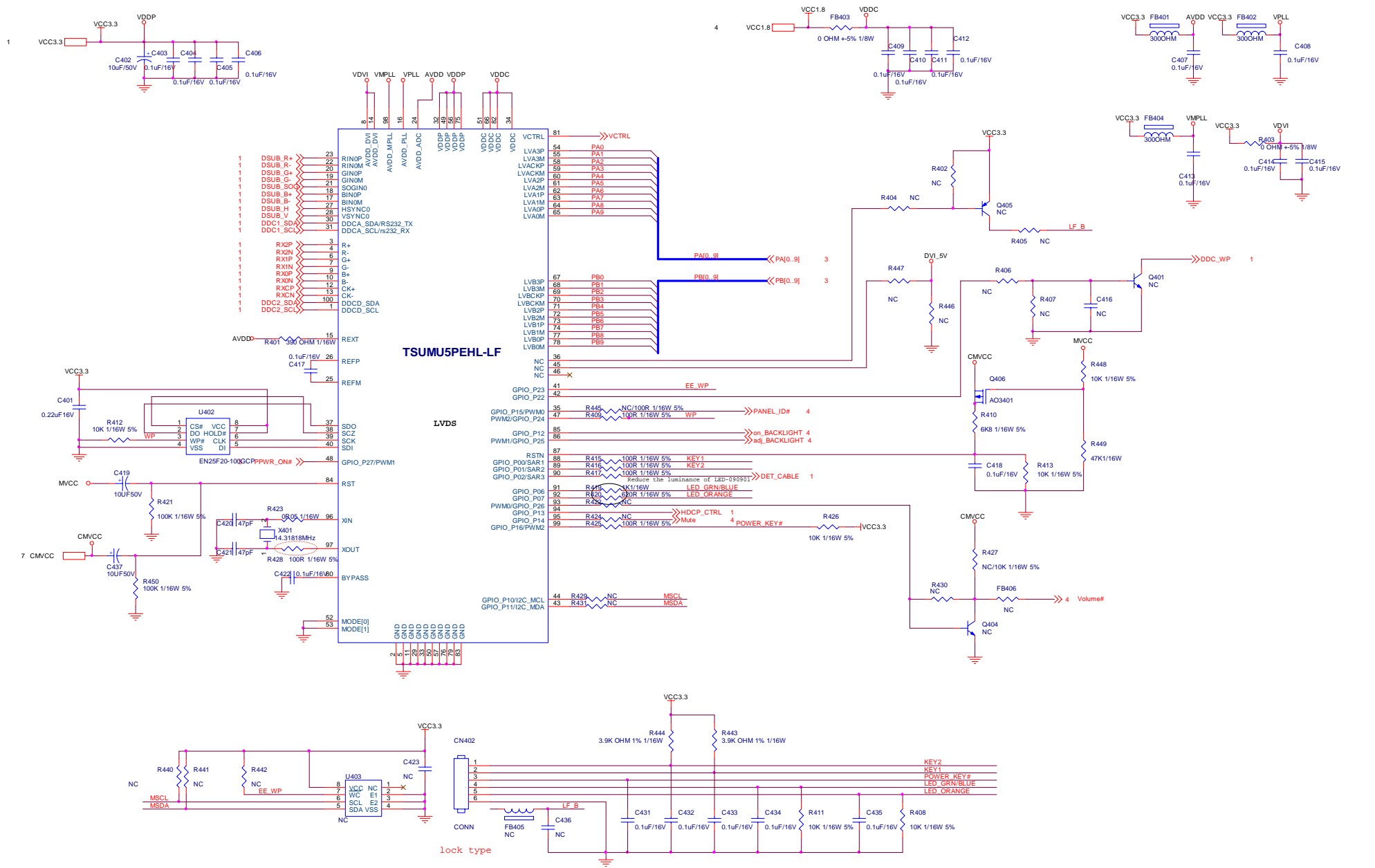

T P V ( Top Victory Electronics Co . . Ltd . )	OEM MODEL	Acer G185H Dual Only	Size	C
慈蔴瓜 總廠	TPV MODEL	G2883-1E-X-37-090901	Rev	E
Key Component	5.0_SCALER	PCB NAME	CBPC0M6AFQH	份數
Date	Tuesday, September 01, 2009	Sheet	5 of 6	<份數>



# T89AM5D8MXAFN2

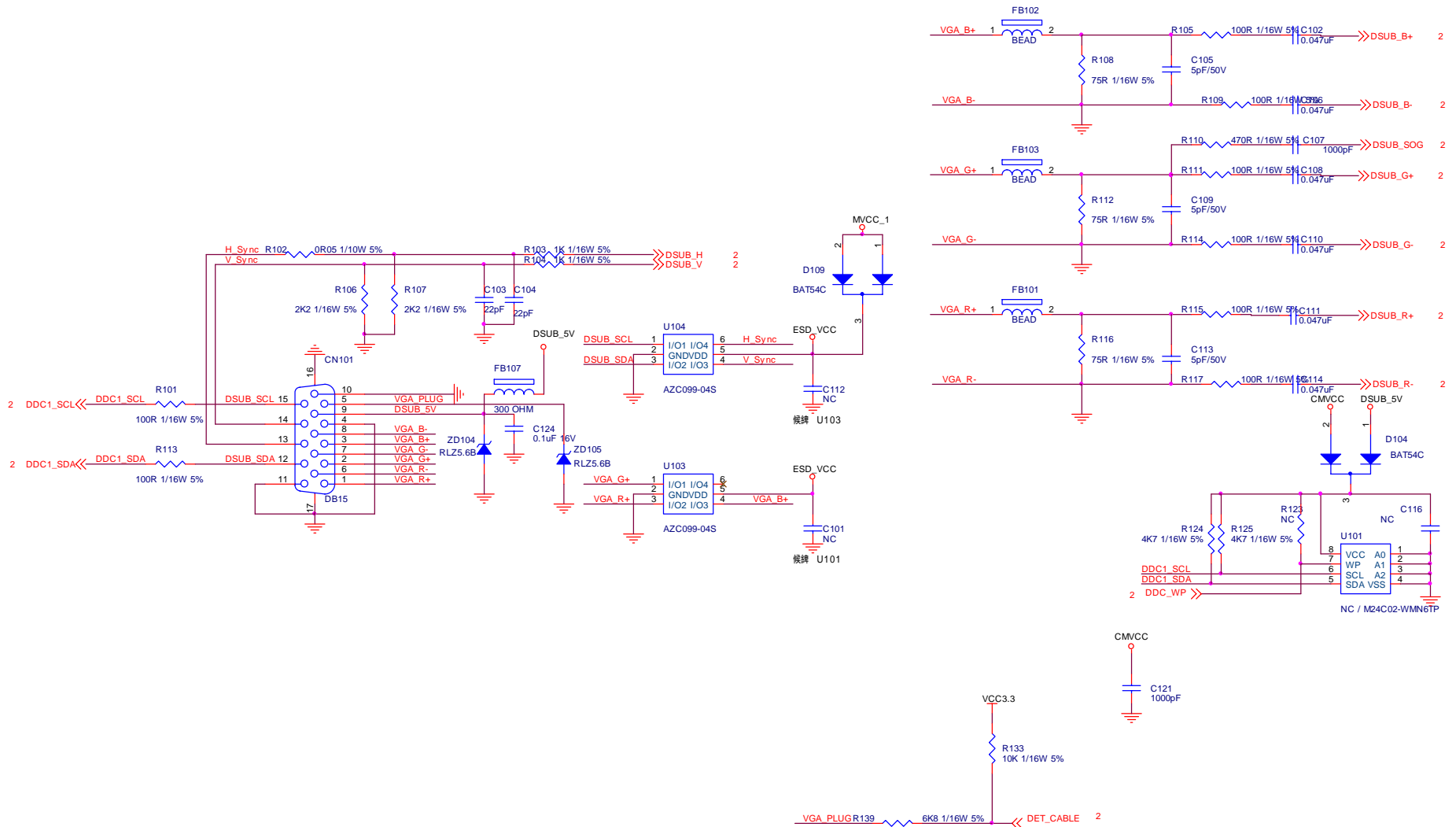

T P V (Top Victory Electronics Co., Ltd.)	OEM MODEL	Acer G185H Analog Only	Size	B	
結構圖	G2883-1-6-X-42-090901	TPV MODEL	CBPC9M5AFQN	Rev	E
Key Component	2.0.INPUT	PCB NAME		稱號	<稱號>
Date	Tuesday, September 01, 2009	Sheet	2 of 6		

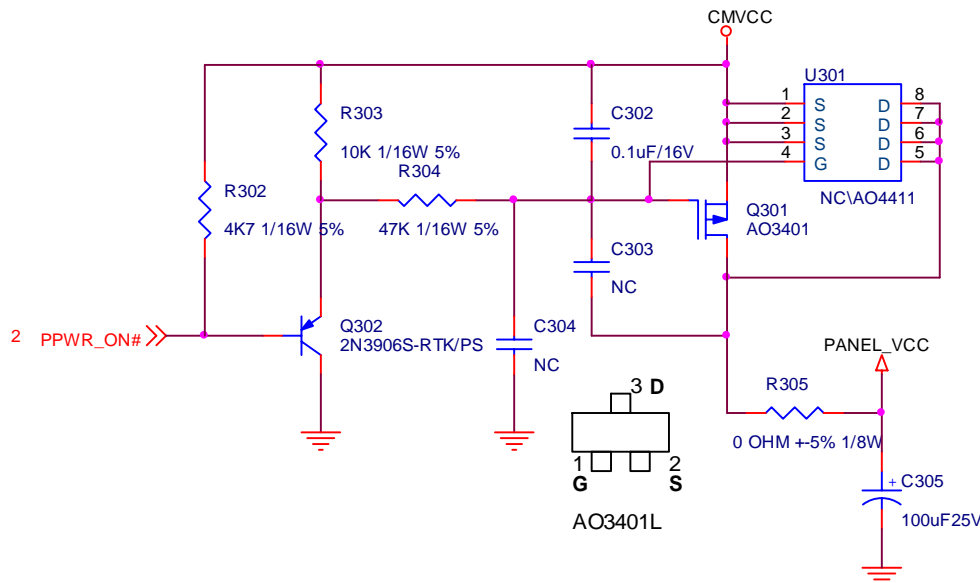
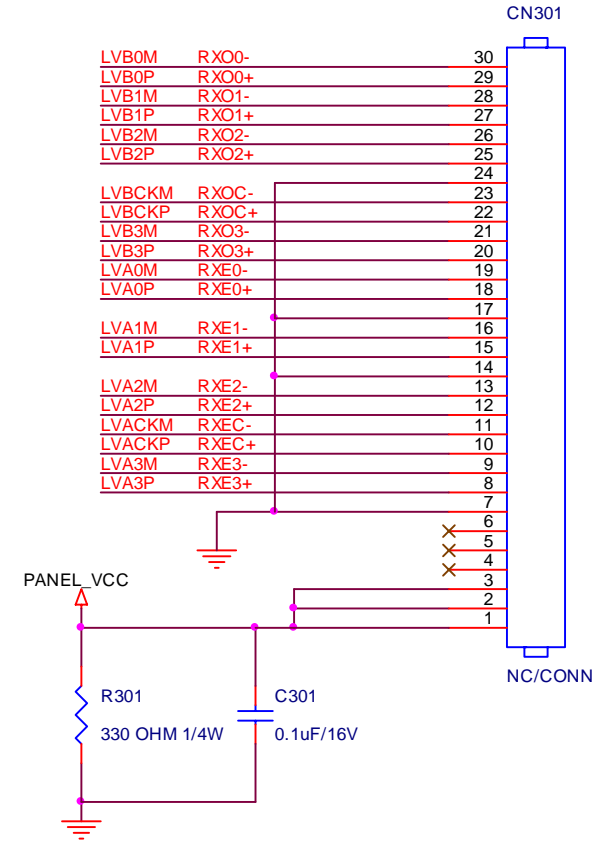
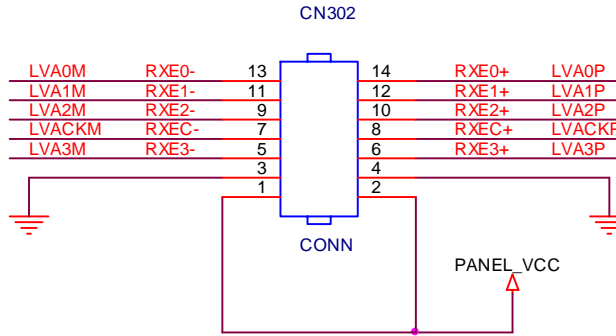
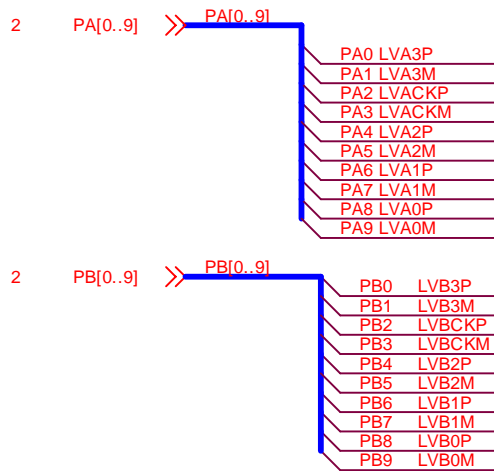

TPV (Top Victory Electronics Co., Ltd.)	OEM MODEL	Acer G185H Analog Only	Size	A	
結 隔 瓜 細 腹	G2883-1-6-X-42-090901	TPV MODEL	CBPC9M5AFQN	Rev	E
Key Component	3.0.OUTPUT	PCB NAME		稱 爹	<稱爹>
Date	Tuesday, September 01, 2009	Sheet	3 of 6		



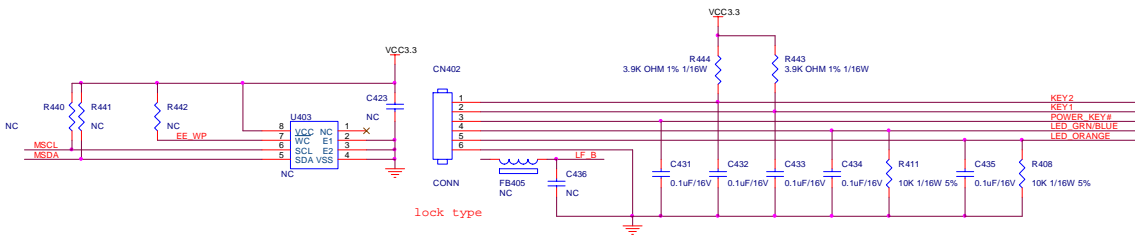
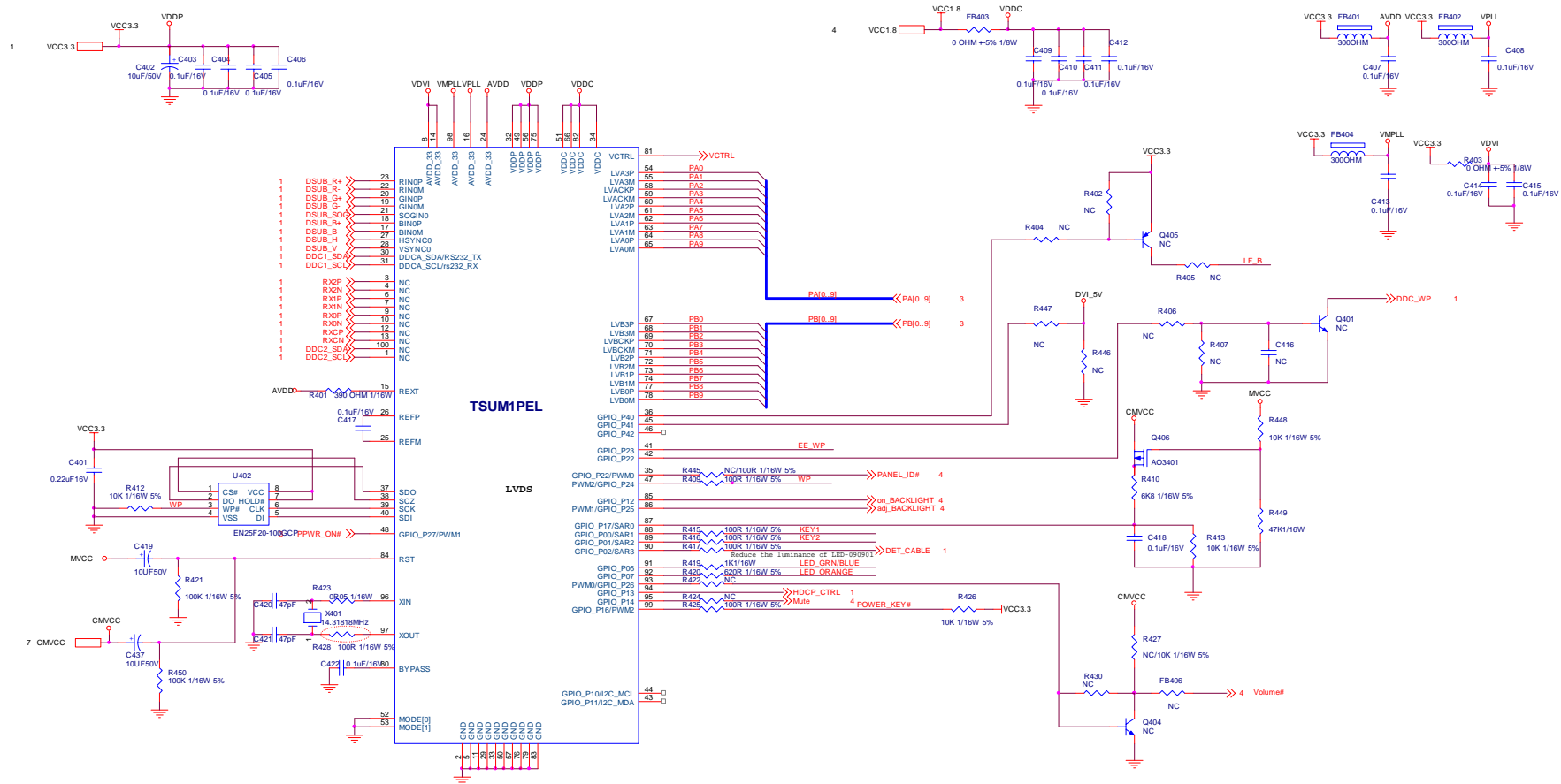

TP V (Top Victory Electronics Co., Ltd.)	OEM MODEL	Acer G185H Analog Only	Size	C
板橋広達	TPV MODEL	CBPC0M5AFQN	Rev	E
Key Component	5.0 SCALER	PCB NAME		
Date	Tuesday, September 01, 2009	Sheet	5 of 6	称数

# Power board

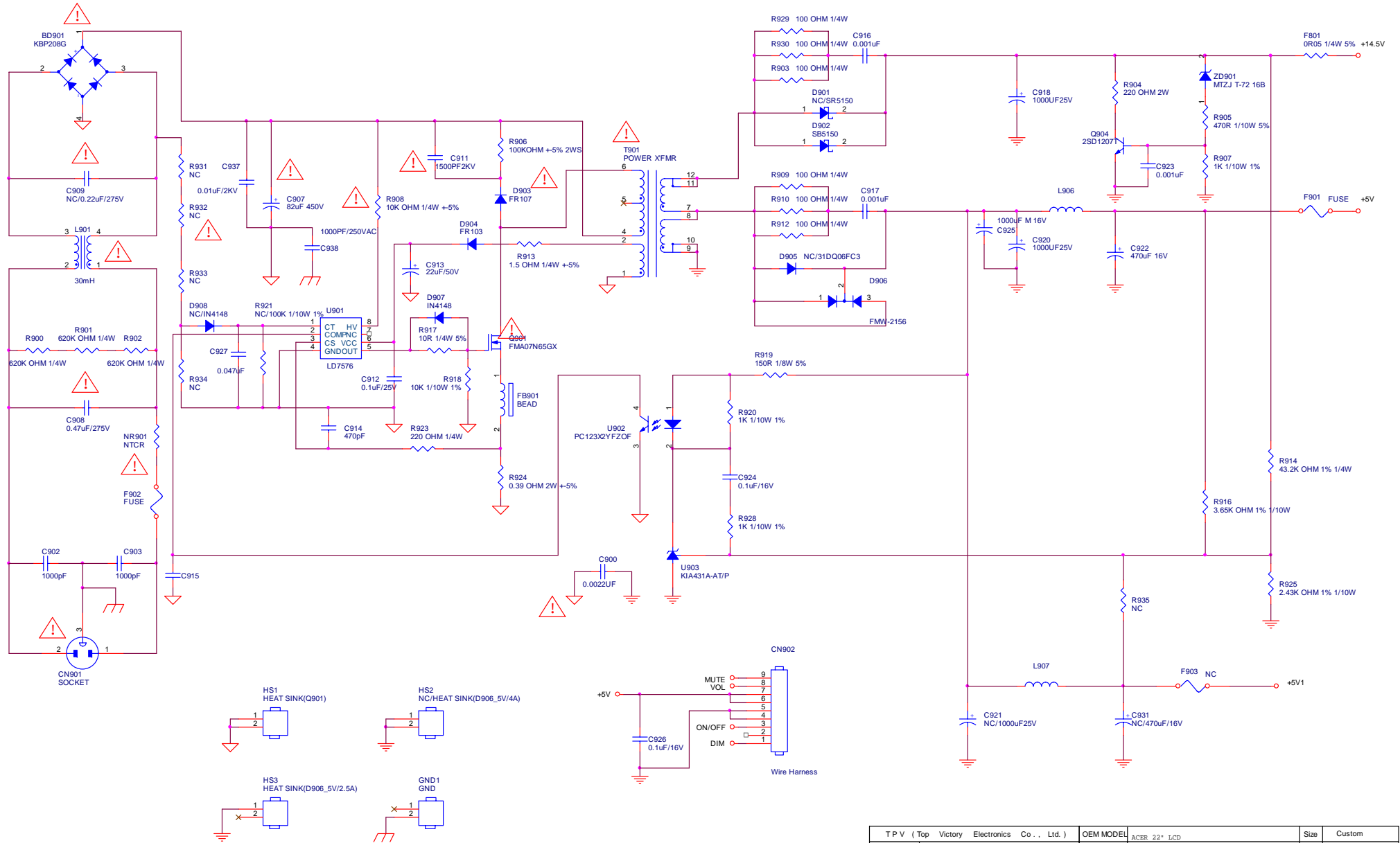

TPV (Top Victory Electronics Co., Ltd.)	OEM MODEL	ACER 22" LCD	Size	Custom
絨隔瓜 繩 腰	G2892-2-3-X-21-090817	TPV MODEL	PWPC9821AQMY	Rev
Key Component	01.POWER	PCB NAME	715G2892-2-3	称 號
Date	Saturday, August 15, 2009	Sheet	2 of 3	ODM MODEL

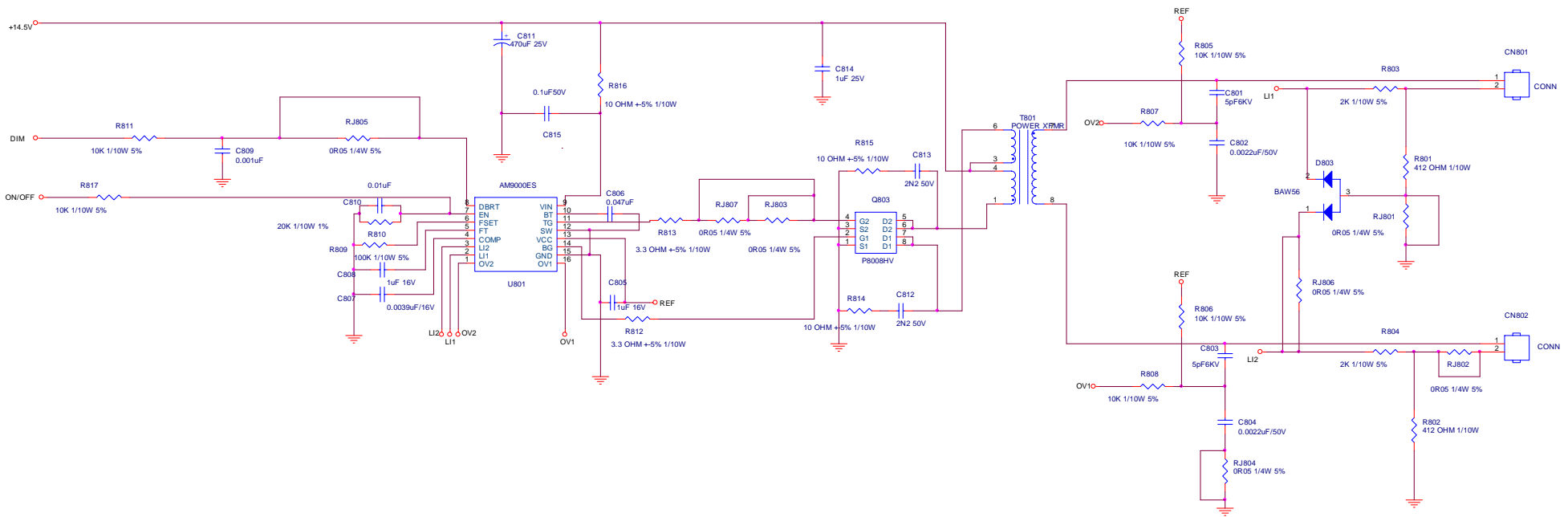

TPV (Top Victory Electronics Co., Ltd.)	OEM MODEL		Size	Custom
桂陽瓜線廠	TPV MODEL	PWPC9821AQM	Rev	1
Key Component	G2.INVERTER	PCB NAME	715G2892-2-3	稱號
Date	Saturday, August 15, 2009	Sheet	3 of 3	ODM MODEL

# Key board

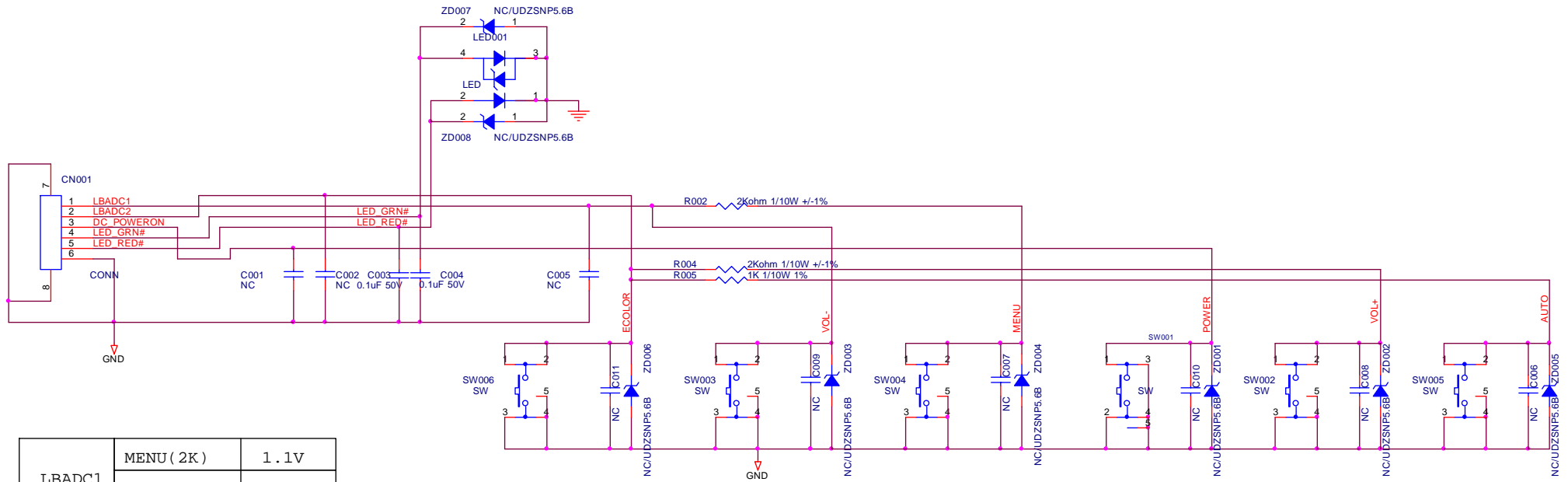

LBADC1	MENU (2K)	1.1V
	VOL- (GND)	0 V
LBADC2	VOL+ (2K)	1.1V
	AUTO (1K)	0.65V
	ECOLOR (GND)	0 V

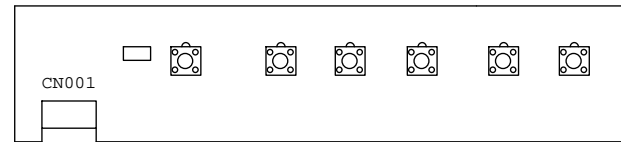

CONNECTOR LED POWER ECOLOR AUTO MENU VOL- VOL+

TPV (Top Victory Electronics Co., Ltd.)	OEM MODEL	G series	Size	B
碓隔瓜 碓隔	G3573-1-X-X-2-20090629	TPV MODEL	ACER	Rev
Key Component	02.Key Board	PCB NAME	715G3573-1	称
Date	Thursday, July 09, 2009	Sheet	2 of 2	<称>