

IMAGE[®] Symphony

Model No. IMSB53950

Serial No. _____

The serial number is on a sign behind the access panel. Write the serial number in the space above.

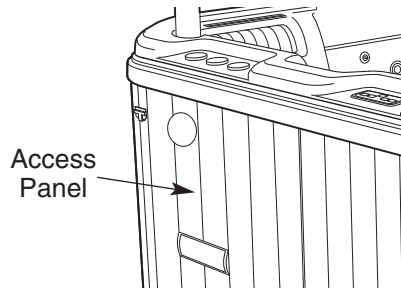

USER'S MANUAL

QUESTIONS?

If you have questions, or if there are missing parts, we will guarantee complete satisfaction through direct assistance from our factory.

TO AVOID DELAYS, PLEASE CALL DIRECT TO OUR TOLL-FREE CUSTOMER HOT LINE. The technicians on our customer hot line will provide immediate assistance, free of charge.

CUSTOMER HOT LINE:

1-877-897-7493

Mon.–Fri., 8 a.m.–5 p.m. CST

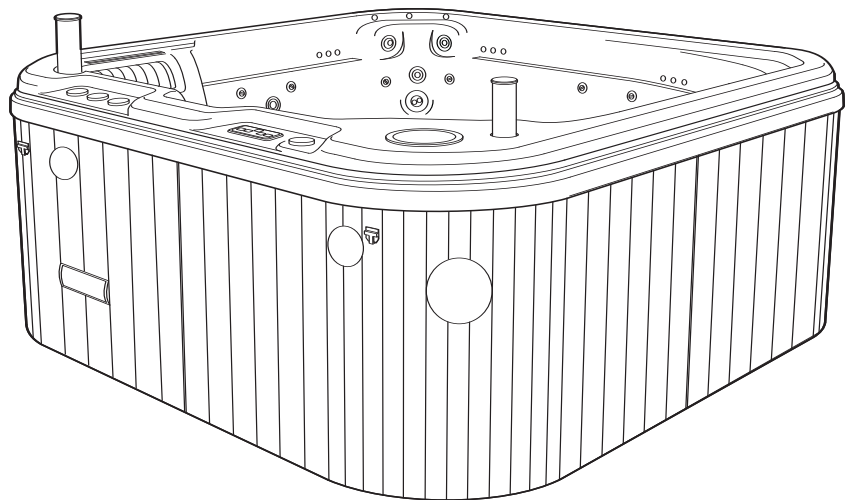

CAUTION

Read all precautions and instructions in this manual before using this equipment. Save this manual for future reference.



Visit our website at

www.workoutwarehouse.com

*new products, prizes,
fitness tips, and much more!*

Table of Contents

Posting the Warning Sign	2
Important Safety Instructions	3
Before You Begin	6
Choosing a Location for the Hydrotherapy Spa	7
Wiring the Hydrotherapy Spa	8
Assembly	9
Using the Hydrotherapy Spa	11
Jet Layout Diagram	13
Using the Controls	14
Maintenance	16
Troubleshooting	20
Part List	22
Exploded Drawing	23
Ordering Replacement Parts	Back Cover
Limited Warranty	Back Cover

Posting the Warning Sign

The warning sign, shown below, must be posted on a wall or fence where it will be visible to all users of the hydrotherapy spa. Whenever the spa is moved, the sign must also be moved and reposted near the spa. If the sign becomes lost or illegible, call our toll-free Customer Hot Line at 1-877-897-7493 to obtain a replacement sign. Post the sign as described above.

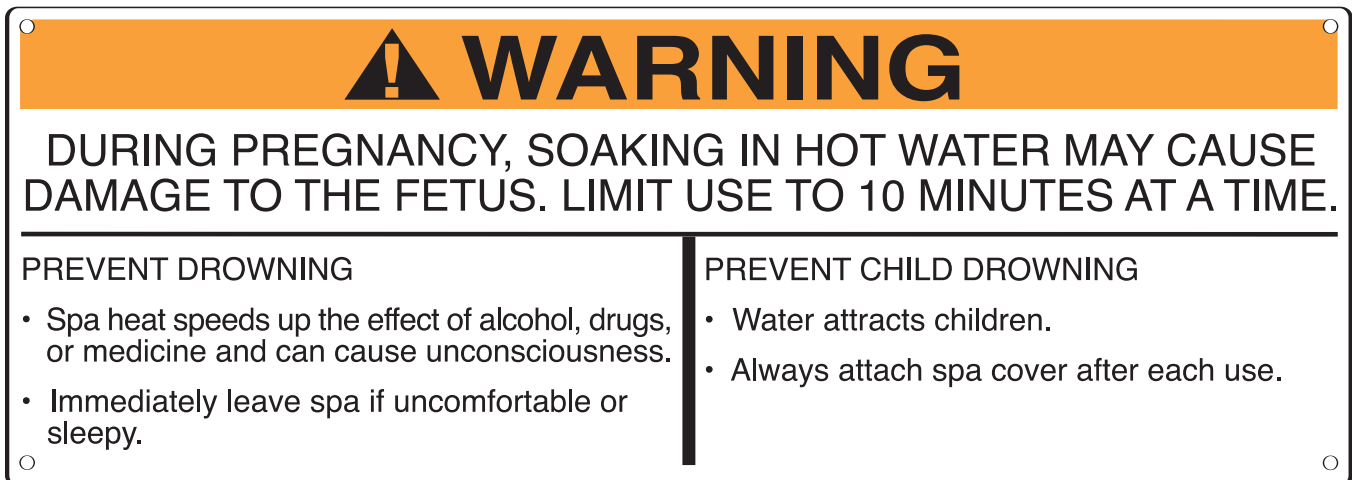

Important Safety Instructions

⚠️ WARNING: To reduce the risk of drowning, electric shock, or serious injury, read the following important precautions before using the hydrotherapy spa.

READ AND FOLLOW ALL INSTRUCTIONS

1. It is the responsibility of the owner to ensure that all users of the hydrotherapy spa are adequately informed of all precautions.
2. Use the hydrotherapy spa only as described in this manual.
3. The hydrotherapy spa is intended for home use only. Do not use the spa in a commercial, rental, or institutional setting.
4. Use the hydrotherapy spa only on a level surface. Do not use the spa on carpet or other materials that could be damaged by moisture.
5. The hydrotherapy spa will weigh approximately 3,300 pounds when it is filled with water. Make sure that the location you select for the spa will support this weight, plus the weight of the occupants.
6. Inspect and tighten all parts regularly. Replace any worn parts immediately.
7. **DANGER—Risk of injury:** Do not remove or alter the covers on the suction fittings. Never operate the hydrotherapy spa if the suction guard is missing or broken. If you need to replace a suction fitting or pump, make sure you use only manufacturer recommended replacement parts. Keep hair and body parts away from the suction guard. Do not allow long hair to float freely in the water; long hair should be restrained with a bathing cap.
8. **IMPORTANT:** Do not allow the hydrotherapy spa to be exposed to direct sunlight when it is empty. The surface of the spa shell can reach temperatures as high as 150°F in a matter of minutes if exposed to the sun while it is empty. These high temperatures can cause significant damage, such as blistering of the shell surface and warping of the spa shell. Any damage caused by sun exposure is not covered under the warranty.
9. Do not bring any object into the hydrotherapy spa that could damage the spa shell.
10. Never insert any object into any opening.
11. Do not use breakable containers in or near the hydrotherapy spa.
12. Do not sit on the spa cover or place objects on it; it is not designed to support weight.
13. Remove any water or debris that may collect on the spa cover.
14. Keep children under the age of 12 and pets away from the hydrotherapy spa when it is not in use.
15. Keep all chemicals away from children and pets.
16. The pH and chemical balance of the water must be maintained as explained in this manual (see pages 12 and 17). Failure to do so may cause injury to users or damage to the hydrotherapy spa, and will void the warranty.
17. Individuals with infections and open sores or wounds should not use the hydrotherapy spa. Bacteria thrive in warm and hot water. Always keep your spa disinfected and maintain the proper chemical balance.
18. Shower before and after using the hydrotherapy spa. This will remove any deodorant, perspiration, or body oils that could contaminate the water. Showering after will remove any residual chemicals and any bacteria that may have been in the spa.
19. **WARNING—**The Ground Fault Circuit Interrupter (GFCI), must be tested before each use. To test the GFCI, press the “test” button while the hydrotherapy spa is running. The spa should shut off. Press the “reset” button. The spa should resume normal operation. If the spa continues to run after the “test” button is pressed, then the GFCI is damaged. Do not use the spa until the GFCI has been repaired or replaced by a qualified electrician.

20. **DANGER**—Risk of electric shock. Keep all electrical appliances such as radios, telephones, televisions, and lights at least five feet away from the water.
21. A wire connector is provided on the electronics pack of the hydrotherapy spa to connect a minimum No. 6 AWG (13.3 mm²) solid copper conductor between the spa and any metal equipment, electrical enclosure made of metal, metal water pipes, or conduit within five feet of the spa.
22. **DANGER**—Risk of electric shock: Do not set the hydrotherapy spa within five feet of any metal objects or surfaces. As an alternative, you may use the spa within five feet of metal objects if each metal object is permanently connected to the wire connector on the electronics pack of the spa by a minimum No. 6 AWG (13.3 mm²) solid copper conductor (see instruction 21).
23. Do not operate the pump motor when the hydrotherapy spa is empty. The pump motor may be seriously damaged if it is operated without water circulating.
24. **DANGER**—Risk of drowning: Exercise extreme caution to prevent unauthorized and unsupervised use of the hydrotherapy spa by children. Children must always be supervised.
25. **DANGER**—To reduce the risk of drowning:
- Never use the hydrotherapy spa alone.
 - Children should not use the spa unless they are supervised by an adult.
 - Keep pets away from the spa at all times.
 - Always replace and lock the spa cover when the spa is not in use.
26. **WARNING**—To reduce the risk of injury: The water temperature should never exceed 104°F. Temperatures between 100°F and 104°F are considered to be safe for healthy adults. However, if you plan to remain in the hydrotherapy spa for more than 10 to 15 minutes, a lower temperature is recommended. Lower temperatures are also recommended for children. Children should not be allowed to swim under the surface of the water in the spa.
27. **WARNING**—To reduce the risk of injury: Before entering the hydrotherapy spa, always use an accurate thermometer to determine the water temperature.
28. **WARNING**—To reduce the risk of injury: Pregnant women should consult with their physician before using the hydrotherapy spa. Pregnant women should not use the spa if the water temperature is above 100°F; the unborn child could be seriously harmed. This is especially important during the first 90 days of the pregnancy.
29. **DANGER**—To reduce the risk of drowning: Prolonged immersion in the hydrotherapy spa may cause hyperthermia. The causes, symptoms and effects of hyperthermia may be described as follows: Hyperthermia occurs when the internal temperature of the body reaches a level several degrees above the normal body temperature of 98.6°F. The symptoms of hyperthermia include an increase in the internal temperature of the body, dizziness, lethargy, drowsiness and fainting. The effects of hyperthermia include failure to perceive heat; failure to recognize the need to exit the spa or hot tub; unawareness of impending hazard; fetal damage in pregnant women; physical inability to exit the spa or hot tub and unconsciousness resulting in danger of drowning. **WARNING:** The use of alcohol, drugs or medication can greatly increase the risk of fatal hyperthermia.
30. **WARNING**—To reduce the risk of drowning: Do not use the hydrotherapy spa if you are under the influence of alcohol or drugs. Heat from the water, in conjunction with alcohol or drugs, can cause loss of consciousness.
31. **WARNING**—To reduce the risk of injury or drowning: Consult your physician about possible side-effects of any medications you may be taking before using the hydrotherapy spa. Heat from the water, in conjunction with some medications, may cause drowsiness and increase the risk of drowning. Other medications can effect blood pressure, heart rate, and circulation.
32. Do not use the hydrotherapy spa immediately after strenuous exercise.
33. If you feel pain or dizziness at any time while using the hydrotherapy spa, discontinue use and contact a physician.
34. **WARNING**—To reduce the risk of injury: It is especially important for persons over the age of 35 or persons with pre-existing health problems, such as obesity, heart disease, high or low blood pressure, circulatory problems, or diabetes to consult their physician before using the hydrotherapy spa.

35. **WARNING:** The spa jets produce a stream of water with relatively high pressure. Prolonged exposure of a localized area of the body may cause bruises to the skin.

36. The included warning sign must be posted where all users of the hydrotherapy spa can see and read it. (See **POSTING THE WARNING SIGN** on page 2.)

37. **WARNING DECAL PLACEMENT:** Locate the decals shown below and familiarize yourself with the information on the decals.

 WARNING	
PREVENT DROWNING <ul style="list-style-type: none">• Supervise your children at all times.• Attach spa cover after each use.• Spa heat can cause hyperthermia and unconsciousness.• Spa heat in conjunction with alcohol, drugs, or medication can cause unconsciousness.	PREVENT ELECTROCUTION <ul style="list-style-type: none">• Never place any electrical appliance within 5 feet of spa.• Read and follow owner's manual and instructions
Note: This marking is to be removed only by the owner	

 WARNING
Continuous exposure of the spa surface to direct sunlight may cause damage to the spa's surface and will void the surface warranty to this spa. To avoid sun damage the cover should be in place when the spa is not in use.

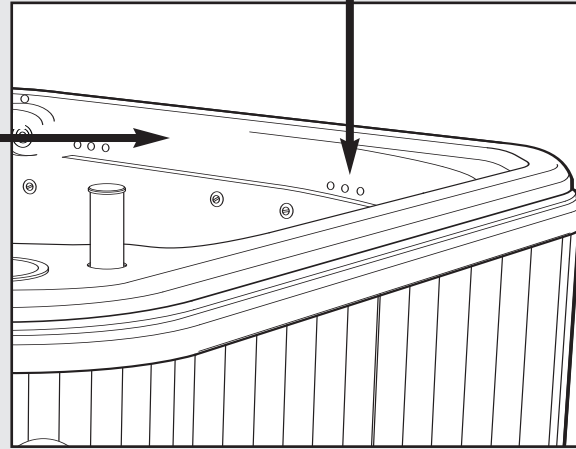

 **WARNING:** Read all instructions before using the hydrotherapy spa. ICON assumes no responsibility for personal injury or property damage sustained by or through the use of this product.

SAVE THESE INSTRUCTIONS

Before You Begin

Congratulations for selecting the new IMAGE® SYMPHONY hydrotherapy spa. The innovative SYMPHONY spa allows you to enjoy all the benefits of hydrotherapy in the comfort and privacy of your home.

Hydrotherapy is a proven method for soothing tired muscles after exercise or for relieving the stress of a busy life. The warm environment stimulates blood flow, which is essential in the healing process, and the powerful massage action further eases tension and stress throughout the body. The IMAGE SYMPHONY hydrotherapy spa gives you the specialized treatment you need to feel your best.

For your benefit, read this manual carefully before using the hydrotherapy spa. If you have questions after reading the manual, please call our Customer Service Department toll-free at 1-877-897-7493, Monday through Friday, 8 a.m. until 5 p.m. Central Time (excluding holidays). To help us assist you, please mention the product model number and serial number when calling. The model number is IMSB53950. The serial number can be found on a decal on the access panel inside the spa (see the front cover of this manual).

Before reading further, please familiarize yourself with the parts that are labeled in the drawing below.

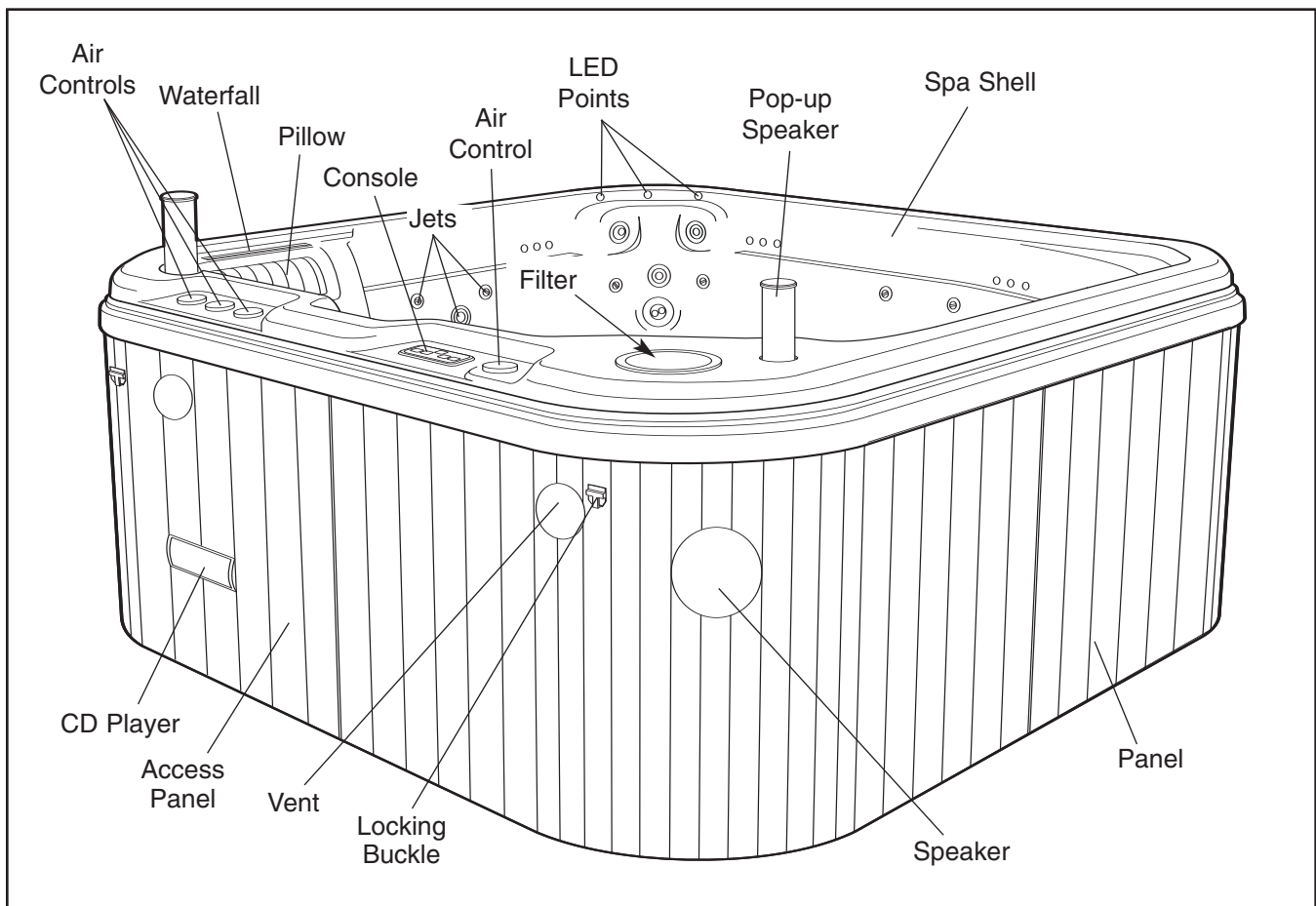

Choosing a Location for the Hydrotherapy Spa

There are many factors to consider when choosing a location to set up the hydrotherapy spa. These factors vary depending on whether you plan to use the spa inside or outside. We have listed several factors you may wish to consider as you decide where to set up the spa.

If you set up the hydrotherapy spa inside:

1. The spa will increase the level of humidity in your home. The location you choose should be well ventilated. You may need to install a ventilation fan or use a dehumidifier.
2. The spa should be located near a power source capable of supplying 240 volts AC power. It must be wired directly into a grounded circuit with a 45 amp circuit breaker and a Ground Fault Circuit Interrupter (GFCI) capable of carrying 45 amps. (See WIRING THE HYDROTHERAPY SPA on page 8). No other appliance should be on the same circuit.
3. The spa should be close to a source of water.
4. Do not use the spa on carpet or other material that may be damaged by moisture. We recommend that you place the spa on a water- and stain-resistant, non-slip surface with a floor drain for any water that may splash from the spa.
5. Make sure that the location you choose is stable. It must be able to support the weight of the spa when it is filled with water, plus the weight of the occupants. The spa weighs approximately 3,300 pounds when it is filled with water.
6. Do not use the spa above a finished living area, due to the risk of water damage.
7. Make sure that there is room around the spa to permit servicing of the unit. The dimensions of the spa are 84" W x 84" L x 36" H. You should allow for this size when choosing the location.
8. The spa is not designed for in-floor installation. However, it is compatible with a deck system that is built flush with the top of the spa, provided you leave access to the motor for service.
9. Make sure to note any other considerations, such as aesthetics or privacy concerns, that may affect the safety or enjoyment of using the spa.

If you set up the hydrotherapy spa outside:

1. Check local building codes concerning the use of outdoor spas.
2. The spa should be located near a power source capable of supplying 240 volts AC power. It must be wired directly into a grounded circuit with a 45 amp circuit breaker and a Ground Fault Circuit Interrupter (GFCI) capable of carrying 45 amps. (See WIRING THE HYDROTHERAPY SPA on page 8). No other appliance should be on the same circuit.
3. The spa should be close to a source of water.
4. We recommend that you place the spa on a water- and stain-resistant, non-slip surface. Do not use the spa on rough or sharp surfaces such as gravel or wood chips.
5. Make sure that the location you choose is stable. It must be able to support the weight of the spa when it is filled with water, plus the weight of the occupants. The spa weighs approximately 3,300 pounds when it is filled with water.
6. Consider environmental factors such as rain, wind, shade, and sunlight.
7. You should be able to monitor the use of the spa from your home, to prevent unauthorized use by children. You may want to enclose the spa with a fence and self-latching gate to prevent unauthorized use.
8. Make sure that there is room around the spa to permit servicing of the unit. The dimensions of the spa are 84" W x 84" L x 36" H. You should allow for this size when choosing the location.
9. The spa is not designed to be installed below ground level. However, it is compatible with a deck system that is built flush with the top of the spa, provided you leave access to the motor for service.
10. Make sure to note any other considerations, such as aesthetics or privacy concerns, that may affect the safety or enjoyment of using the spa.

Wiring the Hydrotherapy Spa

This procedure must be performed by a qualified, licensed electrician in accordance with the national electric code, and with all local, state, and federal electric code. Under no circumstances should the hydrotherapy spa be wired by someone other than a qualified electrician.

Before you have the spa wired, make sure it is in the desired position, and that it can be easily serviced, if needed.

The spa operates on a 240 volt power source. It must be wired directly into a grounded circuit with a 45 amp circuit breaker and a Ground Fault Circuit Interrupter (GFCI) capable of carrying 45 amps. **No other appliance should be on the same circuit.**

A wire connector is provided on the electronics pack of the spa to connect a minimum No. 6 AWG (13.3 mm²) solid copper conductor between the spa and any metal equipment, electrical enclosure made of metal, metal water pipes, or conduit within five feet of the spa.

Three options for wiring the spa are shown at the right. A wiring diagram is also found on the inside of the electronics pack for reference.

Option 1

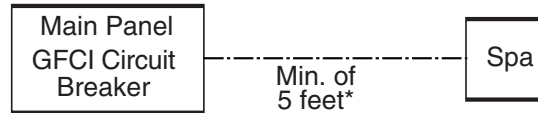

Wire Length	Suggested Wire Size
5 Feet to 25 Feet	6 AWG
25 Feet to 50 Feet	4 AWG
More than 50 feet not recommended	

* The hydrotherapy spa must be placed a minimum of five feet from the Main Panel.

Option 2

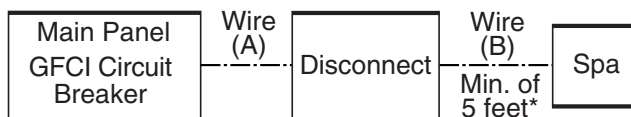

Wire Length	Suggested Wire Size	
	A	B
5 Feet to 25 Feet	6 AWG	6 AWG
25 Feet to 50 Feet	4 AWG	4 AWG
50 Feet to 100 Feet	2 AWG	4 AWG
More than 100 feet not recommended		

* The hydrotherapy spa must be placed a minimum of five feet from the Disconnect.

Option 3



Wire Length	Suggested Wire Size	
	A	B
5 Feet to 25 Feet	6 AWG	6 AWG
25 Feet to 50 Feet	4 AWG	4 AWG
50 Feet to 100 Feet	2 AWG	4 AWG
More than 100 feet not recommended		

* The hydrotherapy spa must be placed a minimum of five feet from the Disconnect.

Assembly

Place all parts of the hydrotherapy spa in a cleared area and remove the packing materials. Do not dispose of the packing materials until assembly is completed.

Assembly requires your own phillips screwdriver .

1. **Before beginning assembly, make sure that you have read and understand the information above and on the previous two pages.**

Remove the eight #10 x 2" Machine Screws (37) that secure the indicated Access Panel (25) to the spa. Carefully remove the Access Panel until the CD wire harness (not shown) is visible, and disconnect the CD wire. Set the Access Panel aside. **Be careful not to damage the spa shell.**

Insert the Pillow (38) into the lounge seat receptacle. Note: The Pillow can be rotated 180° and reattached in a high or low position.

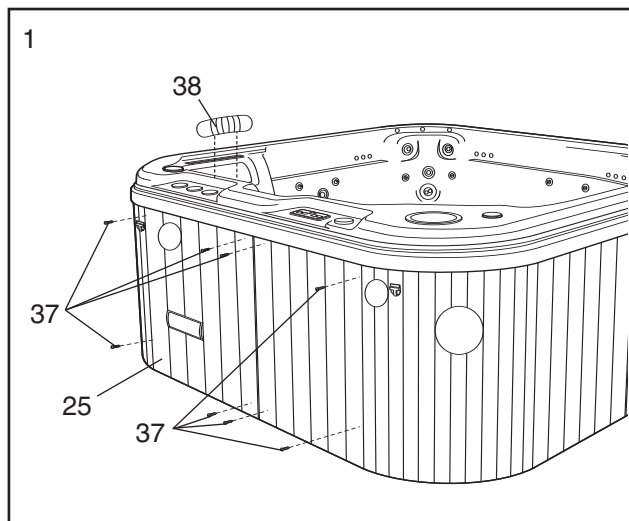

2. Close the valve knob on the drain hose. Thread the cap onto the drain hose.

Locate the four gate valves inside the access opening (there are two gate valves per pump). Turn the gate valves counterclockwise to open them.

Make sure that the six collars are tightened (there are two collars per pump and two on the heater).

See step 1. Reconnect the CD wire harness to the CD Player and reattach the Access Panel (25) to the spa.

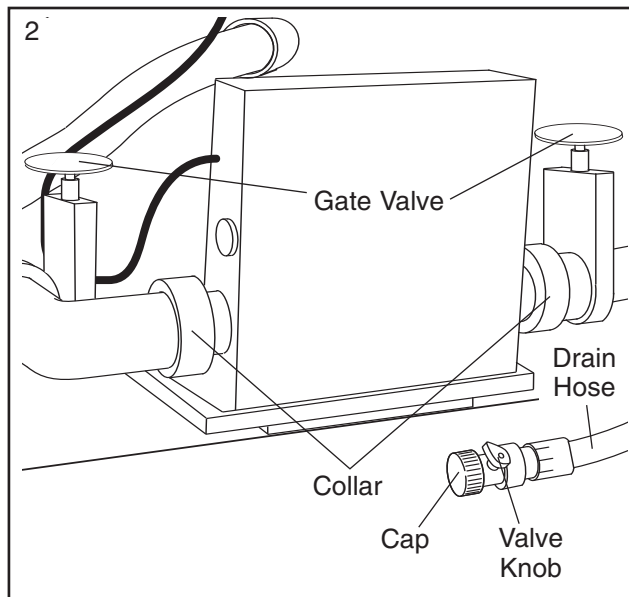

3. **Make sure that a qualified electrician has wired the spa to a 240 volt power source.**

Remove the two warning decals (see page 5) from the spa shell. Using a damp cloth, wipe the spa shell clean. **Before filling the spa, make sure that it is in the desired position and that there is room to easily service it. Once the spa is filled, it must be drained before it can be moved.**

Insert a garden hose into the filter housing, and begin filling the spa. **Do not use soft water.** The spa may be filled with cold water; however, if warm or hot water is used, the spa will be ready for use sooner. Fill the spa until the water is at the level of the molded fill line. **Do not overfill the spa.**

See the inset drawing. Set the Filter (5) and the Basket (22) in the filter housing. Next, place the Filter Cover (3) in the filter housing.

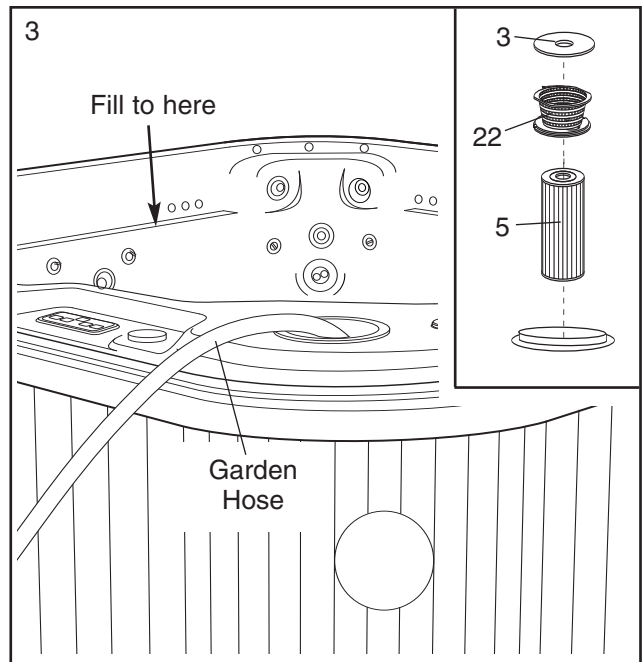

4. Pull down one of the straps on the Spa Cover (11) and hold the Buckle (26) against one of the panels on the spa. (Note: To position the Buckle correctly, have a second person hold the strap on the opposite side of the Spa Cover snug.) **The Spa Cover must be snug. Do not place the Buckle over the grooves between the premium cedar panels.** See the inset drawing. Remove the latch from the Buckle (26). Attach the Buckle to the panel with two #4 x 3/4" Screws (27).

Attach the other three Buckles (26) to the panels in the same way.

Remove the Spa Cover (11) from the spa.

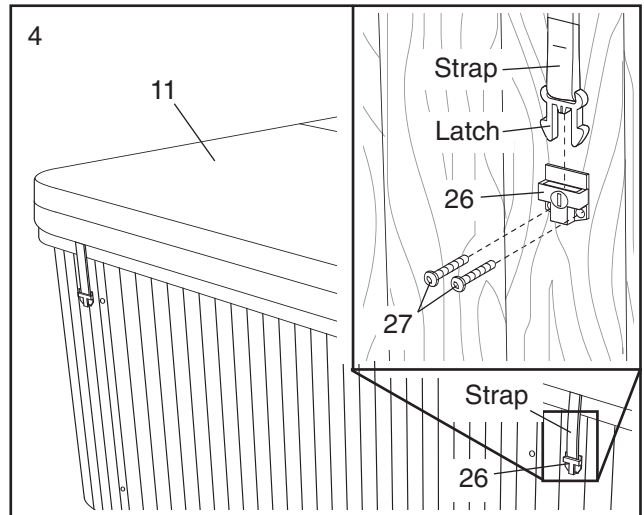

Using the Hydrotherapy Spa

The hydrotherapy spa is designed to seat seven adults. The spa holds approximately 375 gallons of water and offers a heating system (80°F to 104°F), a filtration system, and adjustable hydrotherapy jets. Follow the guidelines below to use and maintain the spa for your long-term enjoyment.

Once the spa is filled with water, the power can be turned on. **Note: If this is the first time the spa has been turned on, or if the pumps have been drained, the pumps must be primed before the spa can be used.**

PRIMING THE PUMPS

To prime the pumps, follow the steps below.

1. Remove the access panel (see ATTACHING AND REMOVING THE ACCESS PANEL on page 18).
2. Make sure all of the valves in the plumbing system are open to allow as much air as possible to escape from the plumbing and the controller during the filling process. Fill the spa to the level shown in step 3 on page 10. Use towels to soak up any water that leaks from the plumbing and pumps during the priming process.
3. Loosen the indicated collar on one of the pumps to vent the air from the pump. Repeat for the other pump. Allow a small amount of water and air to escape from the pumps and related plumbing. Then, retighten the collars.
4. Turn the power on at the breaker. The spa will begin an automatic priming sequence.

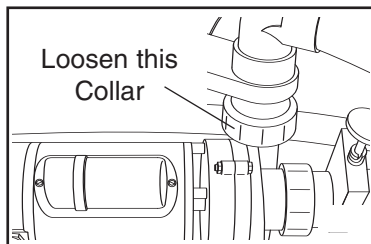

Once the countdown has reached “000,” “Pr” will be displayed. “Pr” indicates that the controller is in the two-pump priming mode. This mode will last for four to five minutes.

5. As soon as “Pr” is displayed, push pump button 1 once to start the pump on low speed and then push the button again to switch to high speed. Repeat for pump button 2.

If water is not flowing from the jets after two minutes, turn the power off. **Important: Do not allow the pumps to run without priming for more than two minutes. Under no circumstances allow a pump to run without priming beyond the end of the four to five minute priming mode.** Doing so may cause damage to the pump and cause the spa to go into an overheat condition.

Repeat the process of venting the air from the pumps and the controller and priming the pumps until water flows from the jets.

6. When the priming sequence is completed, the spa will automatically return to the normal heating and filtering mode. During the priming process, the heater is disabled to allow the pumps to be primed without activating the heater under low flow or no flow conditions.

Once the pumps are primed, push pump button 1 and pump button 2 to turn the pumps off.

7. The console will display “100F” and then “--F,” for approximately one minute. The spa requires one minute of water flowing through the heater to determine the water temperature.

A countdown from “005” to “000” will appear in the display of the console.

- After one minute, the current temperature of the water will be displayed. Push the temperature up or down button to set the temperature of the water. If the water temperature is below the set temperature, the heat indicator light will turn on to show that the water is being heated.

The controller will automatically heat the water and all of the features of the console will be available. To use the console, see USING THE CONTROLS on page 14.

- Remove the towels and reattach the access panel (see ATTACHING AND REMOVING THE ACCESS PANEL on page 18).

TESTING AND TREATING THE WATER

The first time you use the spa, you should test and treat the water. **You must also treat the water each time you refill the spa.** A test strip and a chemical pack are available at your local pool and spa store. Follow the directions carefully on the chemical pack to test and treat the water. **Always keep the chemicals away from children and pets.**

See WATER CHEMISTRY on page 17 for information concerning proper water maintenance.

STARTING THE HYDROTHERAPY SPA

You should always test the GFCI before using the hydrotherapy spa. First, turn on the spa. Press pump button 1 on the console (see USING THE CONTROLS on page 13). Once the spa is running, press the GFCI “test” button. The spa should shut off. Press the “reset” button. The spa should resume normal operation. If the spa continues to run after the “test” button is pressed, the GFCI is damaged. Do not use the spa until the GFCI has been repaired or replaced by a qualified electrician.

Once you have tested the GFCI, verify that water is flowing from the jets. Set the air controls to the lowest setting (see USING THE CONTROLS on page 14). Cover the hydrotherapy spa with the spa cover. **The spa cover must be tight** (see SECURING THE SPA COVER ON THE SPA on this page). The water will heat at about 6°F per hour with the cover on. If you are using the spa indoors, and the room temperature is maintained at 70°F, it will take approximately 6 to 8 hours for the water to reach the set temperature.

The temperature and the water flow can be set or changed with the controls on the console (see USING THE CONTROLS on page 14).

USING THE CD PLAYER AND THE POP-UP SPEAKERS

See the included user’s manual for instructions on using the CD player. To use the pop-up speakers, press down on the tops of the speakers. **To store the speakers, press down on the top of the speakers until there is an audible click.**

SECURING THE SPA COVER ON THE SPA

To secure the spa cover, snap the latches on the spa cover into the buckles on the panels. To lock the buckles, insert the key and turn it clockwise 1/4 turn. To unlock the buckles, insert the key and turn it counterclockwise 1/4 turn. **Always keep the buckles locked when the spa is not in use. Keep the keys in a safe place, out of the reach of children.**

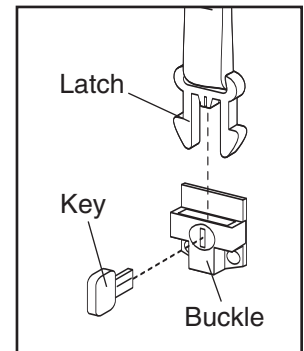

Jet Layout Diagram

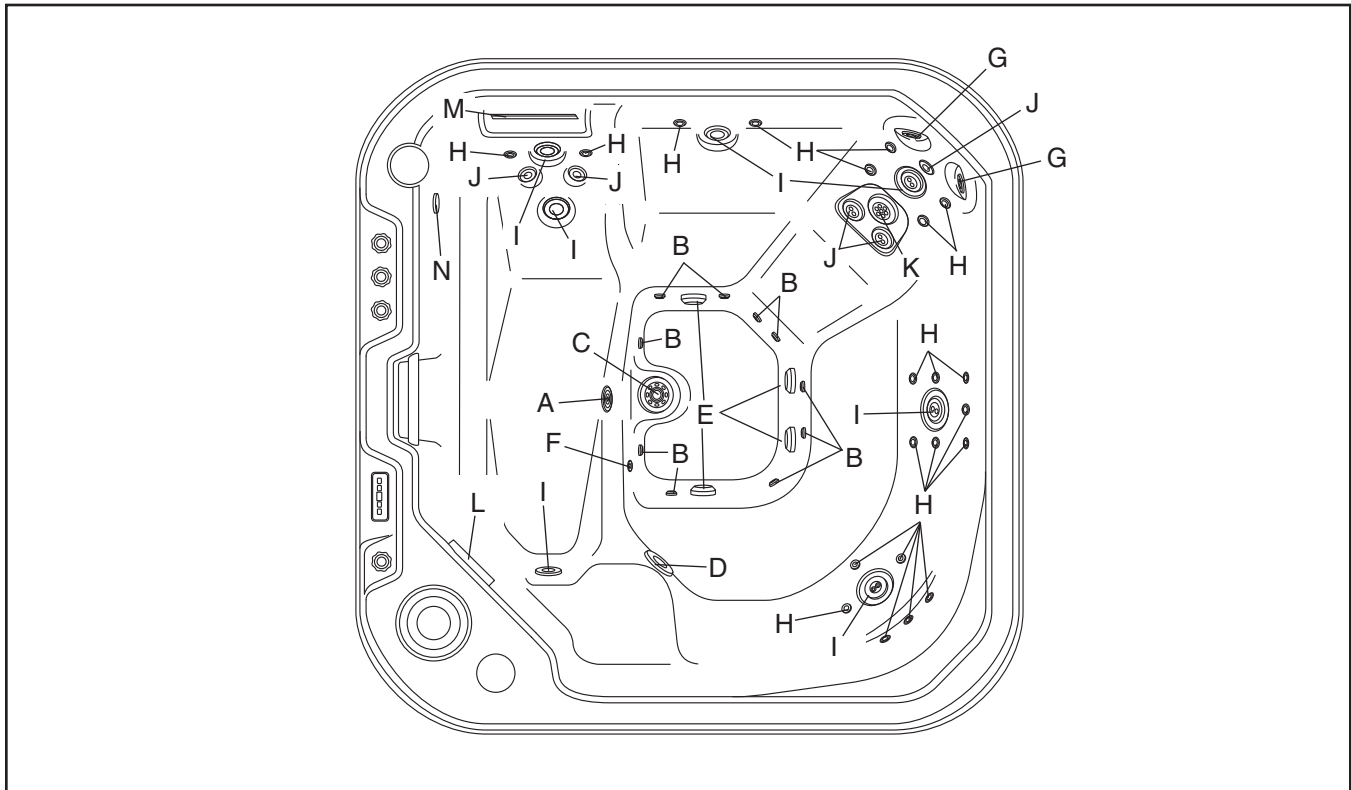

- A. The **underwater light** can be used for night operation (see USING THE CONTROLS on page 14).
- B. The ten **air injectors** create air bubbles that enhance the hydrotherapy experience.
- C. The **volcano jet** provides a soothing foot massage.
- D. The **whirlpool jet** diverts the water flow four different ways. By turning the outer ring, you can divert the water flow between the volcano jet (D), the other jets on the spa, and the whirlpool jet (E), which creates a whirlpool action. **Note: The outer ring may be difficult to turn while the pump is turned on high.**
- E. The four **suction fittings** provide water to the pumps. The suction covers should always be in place over the fittings. Never operate the spa without the suction covers in place.
- F. An optional ozone generator can be purchased and installed to utilize the **ozone jet**. Ozone helps sanitize the spa with minimal chemical treatment.
- G. The two **neck jets** can be adjusted to spray soothing water on your neck.
- H. The twenty-one **rotary jets** provide a spinning massage.
- I. The seven **dual rotary jets** provide a pulsating massage action. Rotate the outer ring counterclockwise to turn the jets on. Rotate the outer ring clockwise to turn the jets off.
- J. The five **variable-flow jets** are fully adjustable. Turn the outer rings to regulate the flow.
- K. The **power massage jet** provides a soothing massage to your lower back. Turn the outer ring to regulate the flow.
- L. The **skimmer** cleans the surface of the water.
- M. The **waterfall** provides a soothing sound and massage.
- N. The **waterfall valve** turns the waterfall off and on.

Using the Controls

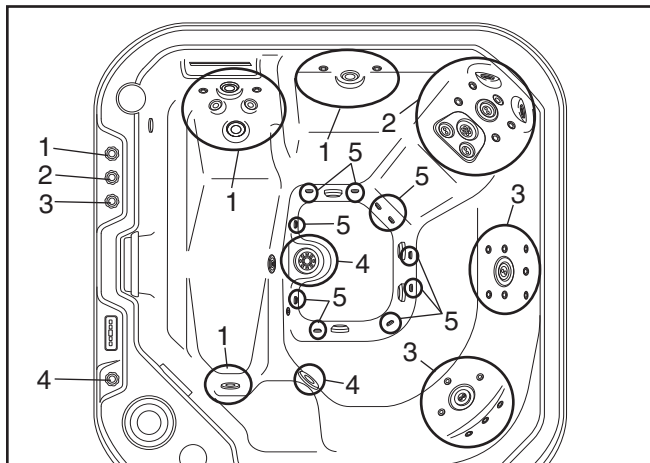
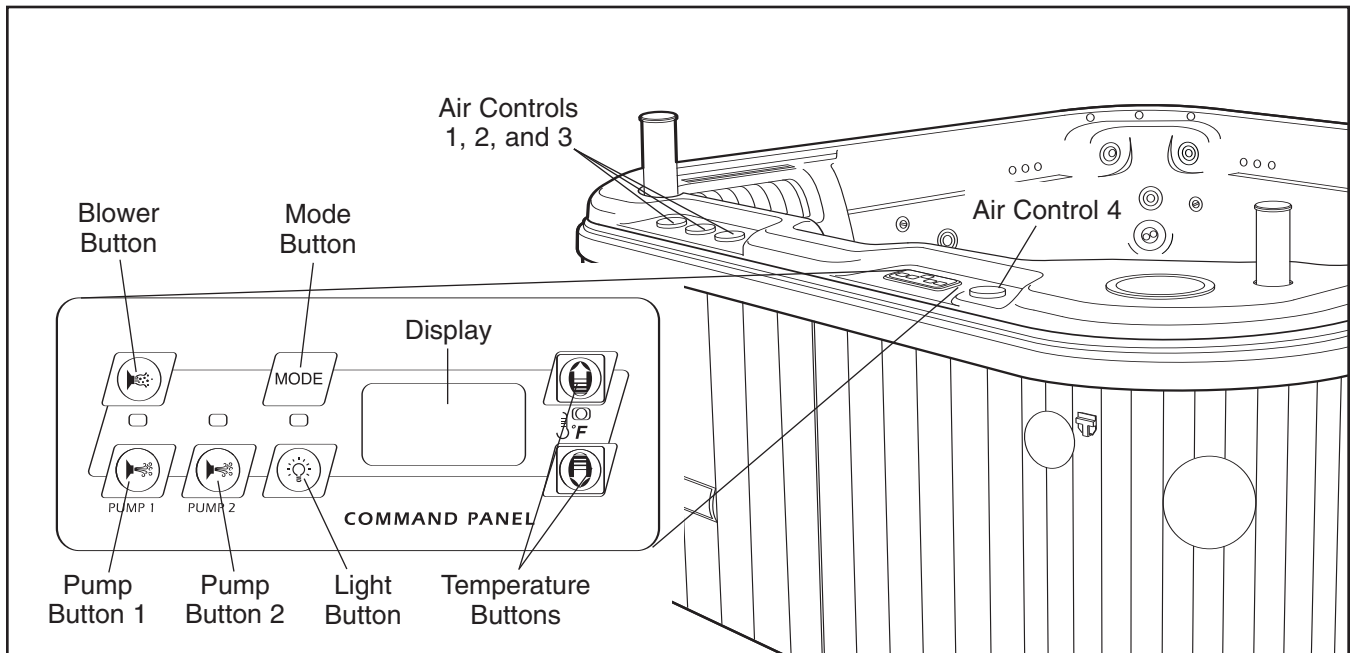

Air control 1 determines the amount of air flowing through the hydrotherapy jets labeled 1 in the drawing above. If the control is turned counterclockwise, the amount of air will increase; if the control is turned clockwise, the amount of air will decrease. Air controls 2, 3, and 4 function in the same manner.

Air controls 2, 3, and 4 determine the amount of air flowing through the hydrotherapy jets labeled 2, 3, and 4 in the drawing above.

The **Mode button** switches the console between Standard, Economy, and Sleep modes.

- Standard Mode maintains the set temperature. Note: The actual temperature displayed will equal the set temperature only when pump 1 has been operating for two minutes. "Std" displays momentarily when

standard mode is selected.

- Economy Mode heats the spa to the set temperature only during the filter cycles. "Ecn" is always displayed when the actual temperature does not equal the set temperature. "Ecn" alternates with the actual temperature when the actual temperature is the set temperature.
- Sleep Mode heats the spa to within 20°F of the set temperature during the filter cycles only. "Slp" is always displayed when the actual temperature does not equal the set temperature. "Slp" alternates with the actual temperature when the actual temperature is the set temperature.

Pump button 1 controls the spa jets labeled 3 and 4 in the drawing at the left. If the button is pressed once, the jets will run at low speed. If the button is pressed again, the jets will run at high speed. If the button is pressed a third time, the jets will shut off.

Pump button 2 controls the spa jets labeled 1 and 2 in the drawing at the left. If the button is pressed once, the jets will run, providing soothing hydrotherapy. If the button is pressed again, the jets will shut off. The spa also features an automatic mode that heats and filters the water when the spa is left unattended. When the power to the spa is first turned on, or if the water temperature is below the set temperature, the water will be heated as required. **Note: To keep the filter and heat cycles from running, the power to the spa must be turned off.**

Your spa features an LED light with twelve different programmed lighting effects:

1. Lights cycle between Red, Green, and Blue
2. Dark Blue
3. Orange
4. Purple
5. Green
6. Red
7. Hot Pink
8. Cyan
9. White
10. Color Spectrum (each color is displayed for approximately one minute)
11. Blue/Green Mix
12. Party Mode™ (colors cycle rapidly through the color spectrum)

The **light button** controls the LED light. To turn the light on, press the light button. To turn the light off, press the light button again. To select the next lighting effect, turn the light off and then within five seconds turn it on again. If the light is left off for more than five seconds, the same lighting effect will be displayed the next time the light is turned on.

The **temperature buttons** control the temperature setting of the water. The temperature setting can be from 80°F to 104°F. The startup temperature is set at 100°F. The water heats at about 6°F per hour with the cover on. Use a medical or other accurate thermometer to check the temperature of the water.

To change the water temperature, press the temperature up or down button until the desired temperature is reached. After three seconds, the console will automatically display the last measured water temperature.

If the temperature sensors detect a drop below 40°F, then pump 1 (and the heater if necessary) will automatically activate to provide freeze protection. The equipment will stay on until the sensors detect that the spa temperature has risen to within 15°F of the set temperature. Pump 2 and the blower will purge for 30 seconds to 2 minutes at the end of the freeze condition.

The **blower button** turns the ten air injectors, labeled 5 in the small drawing on page 14, on and off.

Maintenance

The hydrotherapy spa is designed to provide years of enjoyment. Please follow the guidelines below to properly maintain your spa.

MAINTENANCE SCHEDULE

Daily

- Check the water level and refill the spa to the level shown in step 3 on page 10.
- Check the pH balance and sanitizer level. Make adjustments if necessary (see WATER CHEMISTRY on page 17).

Weekly

- Clean the spa shell at the waterline.
- Check and thoroughly clean the filter (see CHECKING AND CLEANING THE FILTER on this page).
- Replace the filter if needed (see ORDERING REPLACEMENT PARTS on the back cover of this manual).

Monthly

- Clean the spa cover (see MAINTAINING THE SPA COVER on this page).
- Soak the filter for two hours in a trisodium phosphate (TSP) solution. Rinse the filter in clean water.
- Replace the filter if needed (see ORDERING REPLACEMENT PARTS on the back cover of this manual).

Every Three Months

- Drain the spa and refill it with clean water. Sanitize and test the pH of the water.
- Check for any leaks around the pump or joints in the pipes. The seals will wear out over time; detecting leaks early can reduce repair costs.
- Clean the interior of the spa. Do not use solvents or waxes.

MAINTAINING THE SPA EXTERIOR

The surround is maintenance free. The surround should be cleaned with a mild soap solution; do not use solvents or waxes.

CLEANING THE SPA SHELL

The spa shell should be cleaned with a mild soap solution; do not use solvents or waxes. The spa should always be clean and dry before being moved or stored.

MAINTAINING THE SPA COVER

The spa cover should be cleaned monthly. To clean the spa cover, use water and a non-abrasive cleaner on the entire cover. Rinse the cover with a garden hose to remove any cleaner residue. Dry the cover entirely. Use a non-silicone-based vinyl conditioner on the cover after you clean it. This will help protect the cover from sun damage.

CHECKING AND CLEANING THE FILTER

The filter should be checked periodically for build-up of dirt and oil. If the filter needs to be cleaned, follow the steps below:

1. Turn off the power.
2. Lift the filter cover.
3. Lift the basket and the filter out of the filter housing.
4. Check the filter for dirt and debris. If the filter needs to be cleaned, rinse the filter with a hose. If the filter is still dirty, soak it in cleaning solution from a pool and spa supply store.
5. Inspect the filter for damage. Replace the filter if it is damaged.
6. Insert the cleaned or new filter and the basket into the filter housing.
7. Reattach the filter cover.

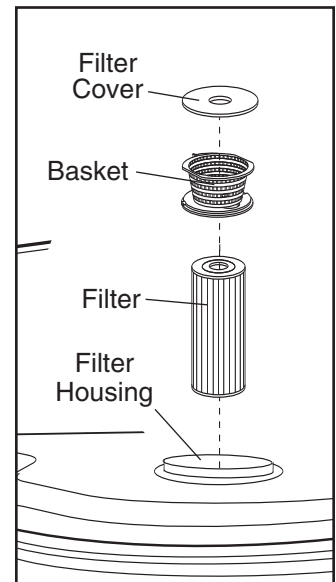

WATER CHEMISTRY

Maintaining the pH level of the water is very important to the operation of the spa. To maintain the proper pH level and to sanitize the spa, you can purchase a chemical starter kit from your local pool and spa supply store.

CAUTION: The chemicals used to maintain the pH balance of the water and to sanitize the water can be dangerous. Always follow these basic guidelines when handling the chemicals:

- 1. Always read and follow the directions on the label, unless directed otherwise.**
- 2. Never mix different chemicals.**
- 3. Do not exceed the recommended amounts of chemicals—follow the directions on the label.**
- 4. Keep all chemicals out of the reach of children and pets.**
- 5. Keep all containers closed tightly when not in use.**
- 6. Never add water to the chemicals—always add the chemicals to the water as directed.**
- 7. Always store chemicals in a cool, dry place.**

MAINTAINING THE PROPER PH BALANCE

The pH factor is a measure of the relative acidity or alkalinity in the water, and is measured on a scale of 1 to 14. Pure water has a value of 7, which is neutral. Any value above 7 is alkaline, and any value below 7 is acidic. You should maintain a slightly alkaline pH level, between 7.2 and 7.8, in the hydrotherapy spa.

Severe problems can occur when the pH balance is not maintained within this range. If the pH level exceeds 7.8, dissolved minerals can build up and clog the plumbing in the spa jet unit. If the pH level falls below 7.2, the acid level in the water will begin to corrode the metal parts in the spa jet unit. Also, the sanitation agents in the water will not be effective if the pH level is not properly maintained. Damage caused by improper pH levels is not covered under the warranty.

To maintain the proper pH level, test the pH of the water regularly. To test the water, purchase a pH test kit at a pool and spa supply store. The pH reading should be between 7.2 and 7.8. If the level is too low, add a pH increaser (usually soda ash). If the level is too high, add a pH reducer (usually sodium bisulfate). Test the water again after five minutes. See the instructions with your pH test kit for additional information about testing and adjusting the pH.

SANITIZING THE HYDROTHERAPY SPA

The most common sanitizing agent is a solid bromine concentrate. The amount required varies according to several factors, such as user load, temperature, and water conditions. Proper water maintenance is a complex process. Contact your local pool and spa supplier for information concerning which chemicals you should use in your area to sanitize the spa.

CHANGING THE FILTER CYCLE

The spa will filter the water every 12 hours. The duration of the cycle can be adjusted to last 2, 4, 6, or 8 hours or run indefinitely. Press the temperature up or down button on the console. When the display begins to flash, press pump button 1. The display will read "F2." To change the time, press the temp up button until the desired time is reached. Press pump button 2 to confirm the selection.

Pump 2 purges for five minutes and the blower purges for 30 seconds at the beginning of each filter cycle. Pump 1 will run on low during filtration and the ozone generator will be enabled.

As spa usage increases, the duration of the filter cycle may need to be increased.

ATTACHING AND REMOVING THE ACCESS PANEL

Turn off the spa power. Remove the eight #10 x 2" Machine Screws (37) that secure the indicated Access Panel (25) to the spa. Carefully remove the Access Panel until the CD wire harness (not shown) is visible and disconnect it. Set the Access Panel aside. **Be careful not to damage the spa shell.**

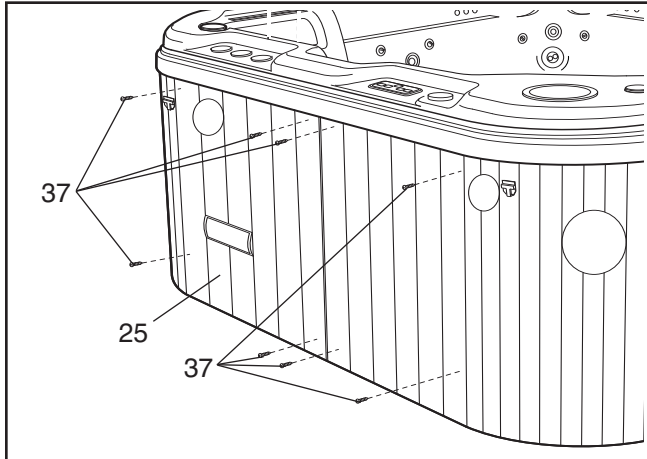

To replace the Access Panel (25), hold the Access Panel in place, connect the CD wire harness to the CD Player and reattach the Access Panel to the spa with the eight #10 x 2" Machine Screws (37). **Be careful not to overtighten the Screws.**

DRAINING THE HYDROTHERAPY SPA

The hydrotherapy spa should be drained at least four times per year and refilled with clean water. You may need to drain the spa more often, depending on the user load. This must be done because after repeated chemical treatment the water becomes chemically saturated. Once this happens, additional chemical treatment of the water is no longer effective. The spa should also be drained if you will not be using it for long periods of time. The spa must always be drained before major repairs are made.

The hydrotherapy spa should always be covered when it is empty. Direct sunlight can cause extensive damage. The surface of the spa shell can reach temperatures as high as 150°F in a matter of minutes if exposed to the sun while it is empty. These high temperatures can cause significant damage, such as blistering of the shell surface and warping of the spa shell. Any damage caused by sun exposure is not covered under warranty.

To drain the hydrotherapy spa, follow the steps below:

1. Using the console, adjust the temperature to the lowest setting.
2. Shut off the power to the spa, at the circuit breaker or GFCI.
3. Remove the access panel from the spa (see ATTACHING AND REMOVING THE ACCESS PANEL on this page).
4. Pull the drain hose out and hold it above the waterline. Remove the cap, open the valve knob, and attach a garden hose to the drain hose. Lower the drain hose and drain the spa.

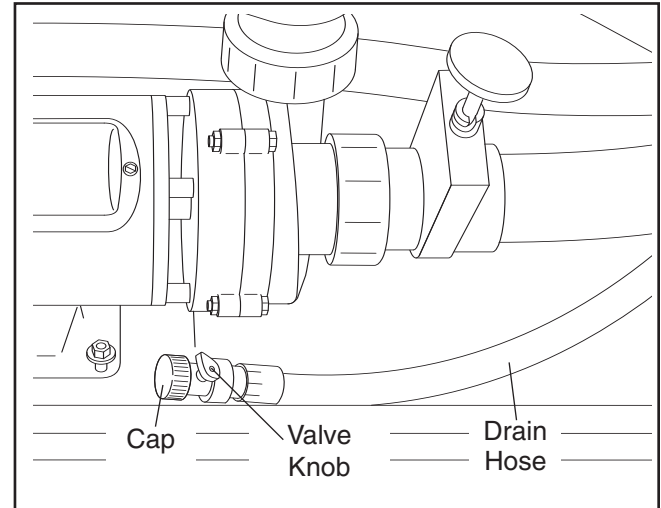

5. When the spa is empty, remove the garden hose, close the valve knob, and reattach the cap and return the drain hose inside the spa.
6. Reattach the access panel.
7. Refill the spa and treat the water with chemicals (see pages 12 and 17).

DRAINING THE PUMPS

After the hydrotherapy spa is drained, the jet pumps should also be drained if the spa will be stored for more than thirty days or if it may be exposed to freezing temperatures.

Turn off the power to the spa. To drain the jet pumps, remove the access panel from the spa (see ATTACHING AND REMOVING THE ACCESS PANEL on page 18). Locate the jet pumps inside the spa. Loosen the indicated collar on each of the pumps.

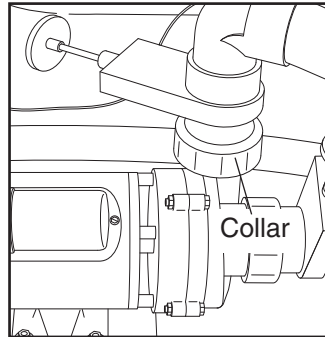

WINTER USE AND CARE

The hydrotherapy spa is designed for year-round use. If you decide to store the spa for the winter, store it in a warm, dry location. Follow the steps below to winterize the spa.

1. Make sure the power to the spa is turned off.
2. Drain the spa (see DRAINING THE HYDROTHERAPY SPA on page 18).
3. Remove all remaining water from the spa shell. Dry the spa shell with towels.
4. Set the air controls to the lowest setting. Use a wet/dry vacuum to pull any remaining water from the system. To do this, place the vacuum nozzle over each jet, starting with the highest jet and finishing with the lowest jet.
5. Set the air controls to the highest setting and repeat step 3.
6. Drain the pumps (see DRAINING THE PUMPS on this page). Once the water is drained from the pumps, place the vacuum nozzle over the drainage hole in the pumps and vacuum any additional water from the pumps. **Note: For additional protection, remove the pumps/motors from the spa and store them in a climate-controlled room.**
7. Clean the spa shell (see page 16).
8. Clean the filter (see page 16).
9. Shut the power off at the breaker. **Label the breaker in such a way that the breaker will not be turned on accidentally.**
10. Reattach the access panel and the spa cover.

REPLACING THE LED LIGHT

Remove the access panels (see ATTACHING AND REMOVING THE ACCESS PANELS on page 18). Make sure the spa power is turned off. Next, locate the light housing. Turn the light housing counterclockwise and remove it from the spa shell.

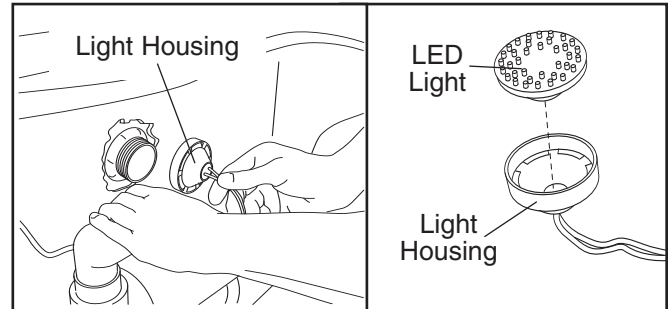

To replace the LED light, pull the old LED light out of the housing and insert a new LED light. Reattach the light housing to the spa shell. Reattach the access panels to the spa.

Troubleshooting

Most problems can be solved by following the simple steps below. Find the symptom that applies, and follow the steps listed. If further assistance is needed, call our Customer Service Department toll-free at 1-877-897-7493, Monday through Friday, 8 a.m. until 5 p.m. Central Time.

1. SYMPTOM: THE SPA WILL NOT OPERATE

- a. Check to see if the GFCI breaker is tripped or was not turned on. Reset the GFCI breaker.

2. SYMPTOM: THE CIRCUIT BREAKER OR THE GFCI TRIPS WHILE THE SPA IS OPERATING

- a. Reset the circuit breaker or the GFCI. If the circuit breaker or the GFCI trips again, contact a qualified electrician for service.

3. SYMPTOM: THE PUMP HUMS

- a. The filter may be dirty or damaged. Remove the filter from the filter housing and clean or replace the filter (see page 16).
- b. The pump may have a foreign object stuck in the impeller. Contact our Customer Service Department.
- c. The pump may have a loose wire connection. Contact our Customer Service Department.

4. SYMPTOM: THE PUMP HUMS, BUT DOES NOT ROTATE

- a. The pump may be jammed. Contact our Customer Service Department. If your spa is no longer under warranty, contact a local spa and pool service provider.

5. SYMPTOM: THE PUMP IS NOISY WHILE OPERATING

- a. There may be debris in the pump. Contact our Customer Service Department.
- b. The pump may have a bad bearing. Contact our Customer Service Department.

6. SYMPTOM: THE WATER DOES NOT HEAT

- a. Make sure that the hydrotherapy spa is fully covered with the spa cover. **The spa cover must be tight for the water to heat.** Set the air control to low. The water will heat at a rate of 6°F per hour. If you are using the spa indoors and the room temperature is maintained at 70°F, it will take approximately 6 to 8 hours for the water to reach the set temperature.
- b. If you are using the hydrotherapy spa outdoors, it may take longer for the water to heat. See the chart below for the approximate heating time.

<u>Air Temperature</u>	<u>Heating Time</u>
70°F +	6 to 8 hours
50°F to 70°F	9 to 11 hours
30°F to 50°F	12 to 14 hours

If the water still has not heated after four days, contact our customer service department.

7. SYMPTOM: THE WATER IS NOT BEING CLEANED BY THE FILTER

- a. Check to see if the filter is in place. Clean the filter if it is dirty.
- b. Check the chemical balance of the water. If the pH is incorrect, the sanitizing agents will not function properly. See the section on maintaining the proper pH balance on page 16.

8. SYMPTOM: THE WATER PULSATES OR THERE IS MINIMUM WATER FLOW

- a. This usually occurs only when the water level is low. Add water until it is 2" to 4" above the skimmer basket.
- b. The filter cover may not be tight. Make sure the filter cover is tight.

9. SYMPTOM: THE WATER LEVEL DROPS

- a. A clamp or seal inside the pump compartment may be loose. Check inside the pump compartment for excess water and watch the pump unit while it is operating to see if water drips from any of the plumbing. If you can identify the location of the leak inside of the spa jet unit, tighten the clamp or replace the damaged seal.
- b. Some water loss due to evaporation is normal. If rapid water loss occurs, or if you notice wetness on the floor around the hydrotherapy spa, the spa shell may have a leak. Contact your local pool and spa service provider for repairs.

10. SYMPTOM: THE SPA JET UNIT CONTINUES TO RUN AFTER IT HAS BEEN SHUT OFF

- a. To turn off the main jets, press pump button 1 once or twice. Note: If the actual temperature of the water in the spa is below the set temperature, or if the spa is running a filter cycle, the heater pump/motor will not shut off.

11. SYMPTOM: THE CONSOLE DISPLAYS "--," "OHH," "ICE," "SnA," "SnB," "SnS," "HFL," "LF," "dr," "OHS," or "drY"

- a. If the console displays one of the messages listed above, or if the console does not function correctly, please call our Customer Service Department.

Part List—Model No. IMSB53950

R0604A

Key No.	Qty.	Description	Key No.	Qty.	Description
1	1	Console With Overlay	32	1	Face Plate
2	2	3-wire Power Cord	33	6	Panel
3	1	Filter Cover	34	2	Heater Collar With Screw
4	8	Rubber Washer	35	1	Volcano Jet
5	1	Filter Cartridge	36	2	Drain Plug
6	2	Rubber Isolator	37	48	#10 x 2" Machine Screw
7	1	CD Player	38	2	Pillow
8	1	Power Supply	39	2	Drain Plug O-ring
9	6	#8 x 1" Sheet Metal Screw	40	4	Corner Panel
10	1	2-speed Pump	41	2	Neck Jet
11	1	Spa Cover	42	1	Filter Housing
12	21	Small Adjustable Pulsating Jet	43	2	Heater Gasket
13	4	Jet Pump/Motor O-ring	44	1	Waterfall Valve
14	1	Controller	45	10	Air Injector
15	5	Adjustable Directional Jet	46	1	Blower
16	7	Adjustable Pulsating Jet	47	1	CD Cover
17	4	Suction Cover	48	2	6" Speaker
18	4	Air Control Knob	49	2	Pop-up Speaker
19	1	1-speed Pump	50	2	4" Vent
20	1	4-wire Power Cord	51	20	LED Point
21	1	Large Rotary Jet	#	2	Ground Wire
22	1	Basket Assembly	#	2	Key
23	8	1/4" Lock Washer	#	1	User's Manual
24	1	Filter Housing Door	#	1	Large Warning Sign
25	2	Access Panel	#	1	Warning Sign
26	4	Buckle	#	1	LED Light
27	8	#4 x 3/4" Screw			
28	8	1/4" x 1 1/2" Screw			
29	1	Overlay			
30	1	Whirlpool Jet			
31	14	1/4" Washer			

#Indicates a non-illustrated part.

Specifications are subject to change without notice.



Air Injector
(45)



Small
Adjustable
Pulsating
Jet (12)



Adjustable
Directional
Jet (15)



Neck Jet (41)

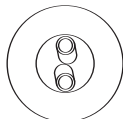

Adjustable
Pulsating
Jet (16)

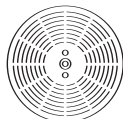

Suction
Cover (17)

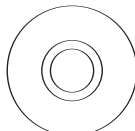

Whirlpool
Jet (30)

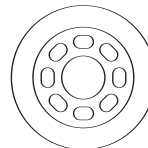

Volcano Jet (35)

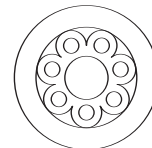

Large Rotary
Jet (21)

Exploded Drawing—Model No. IMSB53950

R0604A

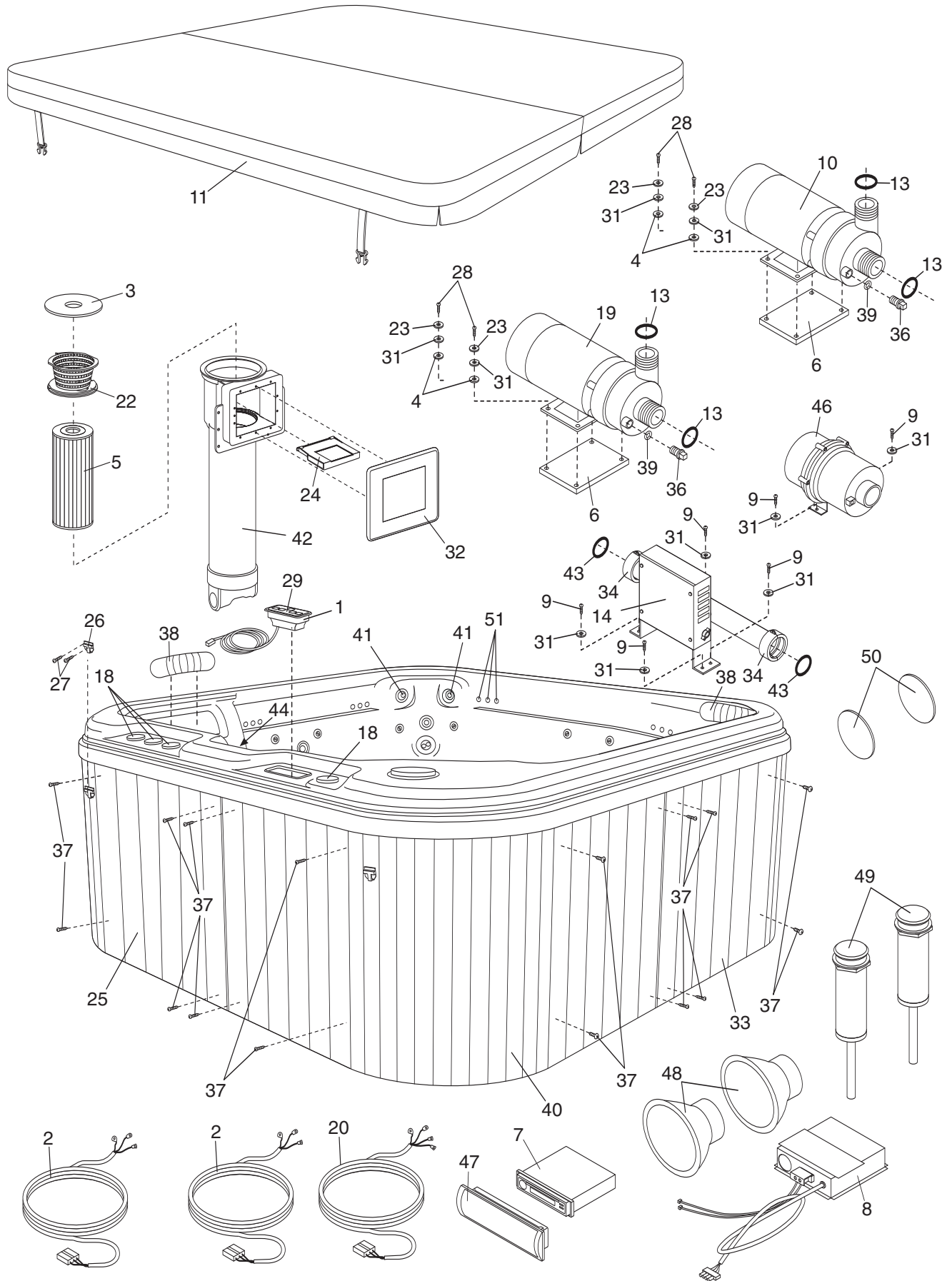

Ordering Replacement Parts

To order replacement parts, simply call our Customer Service Department toll-free at 1-877-897-7493, Monday through Friday, 8 a.m. until 5 p.m. Central Time (excluding holidays). To help us assist you, please be prepared to give the following information when calling:

- The MODEL NUMBER of the product (IMSB53950)
- The NAME of the product (IMAGE SYMPHONY hydrotherapy spa)
- The SERIAL NUMBER of the product (see the front cover of this manual)
- The KEY NUMBER and DESCRIPTION of the part(s) (see the PART LIST and the EXPLODED DRAWING on pages 22 and 23)

Limited Warranty

ICON Health & Fitness, Inc. (ICON), warrants this product to be free from defects in workmanship and material, under normal use and service conditions, for a period of ninety (90) days from the date of purchase. ICON extends a limited five (5) year warranty on the spa shell structure. ICON extends a limited two (2) year warranty on the pump, motor, and electronics package. This warranty extends only to the original purchaser. ICON's obligation under this warranty is limited to replacing or repairing, at ICON's option, the product through one of its authorized service centers. All repairs for which warranty claims are made must be pre-authorized by ICON. This warranty does not extend to any product or damage to a product caused by or attributable to freight damage, abuse, misuse, improper or abnormal usage, or repairs not provided by ICON authorized service personnel; to products used for commercial or rental purposes; or to products used as store display models. Specifically excluded are damages caused by or attributable to the following incidents: any damage to the premium cedar surround or frame attributable to improper handling or freight damage; damage resulting from improper winterization; damage to the spa shell resulting from improper chemical treatment, damage to the spa shell resulting from exposure to extreme temperatures, or damage to the spa shell resulting from exposure to direct sunlight and ultraviolet rays while the spa is empty; damage to the pump, motor, plumbing, and components due to improper maintenance, chemical treatment, or exposure; or damage resulting from failure to properly follow user's manual installation, operating, or maintenance instructions. Also excluded are consumable components, including but not restricted to filter cartridges. No other warranty beyond that specifically set forth above is authorized by ICON.

ICON is not responsible or liable for indirect, special or consequential damages arising out of or in connection with the use or performance of the product or damages with respect to any economic loss, loss of or damage to property including water damage, loss of revenues or profits, loss of enjoyment or use, costs of removal, installation or other consequential damages of whatsoever nature. Some states do not allow the exclusion or limitation of incidental or consequential damages. Accordingly, the above limitation may not apply to you.

The warranty extended hereunder is in lieu of any and all other warranties and any implied warranties of merchantability or fitness for a particular purpose is limited in its scope and duration to the terms set forth herein. Some states do not allow limitations on how long an implied warranty lasts. Accordingly, the above limitation may not apply to you.

This warranty gives you specific legal rights. You may also have other rights which vary from state to state.

ICON HEALTH & FITNESS, INC., 1500 S. 1000 W., LOGAN, UT 84321-9813