

# Microwave Oven

Model: HDA-2070M

Owner's Manual

# Haier

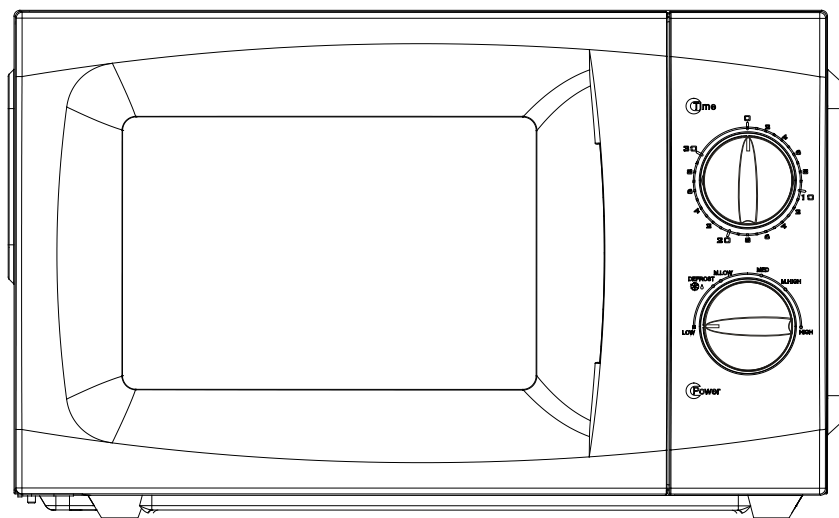

*Please read this booklet carefully before fixing and using and save it for future reference.*

## **OPERATION THEORY OF MICROWAVE OVEN**

1. Microwave is a kind of high frequency electromagnetic wave, which is commonly distributed in the nature. But the existing form of microwave is dispersed so that it cannot be collected together for heating purpose. The key component of magnetron of microwave oven will transform the energy of electricity to microwave and huge energy of microwave field is established under the closed cavity. So the molecule of food is caused to vibrate at very high speed and the friction heat produced will cook the food in a fast way.

2. There are 3 properties of microwave:

a) Absorbability: the microwave can cause the excess vibration of molecule of various food so as to obtain the heating purpose. But the infiltration ability is largely depends on the size, thickness and properties of the food.

b) Penetrability: microwave can penetrate through ceramics, glass, temperature-resistant plastics. It is required to use the containers whose material have good microwave penetrability to achieve best heating result. Please see the below utensils guide.

c) Reflectivity: microwave would be reflected by the metal wall of interior cavity so as to establish an even magnetic field, thus can prevent the overheating of partial area.

## **INSTALLATION OF MICROWAVE OVEN**

1) To ensure sufficient ventilation, the distance from the back of microwave to the wall should be above 10cm, the side to the wall above 5cm, the top to the ceiling above 20 cm.

2) Do not place any objects on the top of microwave oven.

3) Keep the microwave oven far from the TV, Radio or antenna as picture disturbance or noise may occur.

4) Keep the plug to accessible to the socket.

5) The microwave oven is intended to be used freestanding and shall not be placed in a cabinet.

6) To keep the microwave oven at a distance from the wall, it is necessary to install a distance limiter. Here, we have two types of distance limiters in different shape for your reference, however, the case will be that first you take the distance limiter out of the accessories bag in the cavity, and then decide between the alternatives given below to make an available installation.

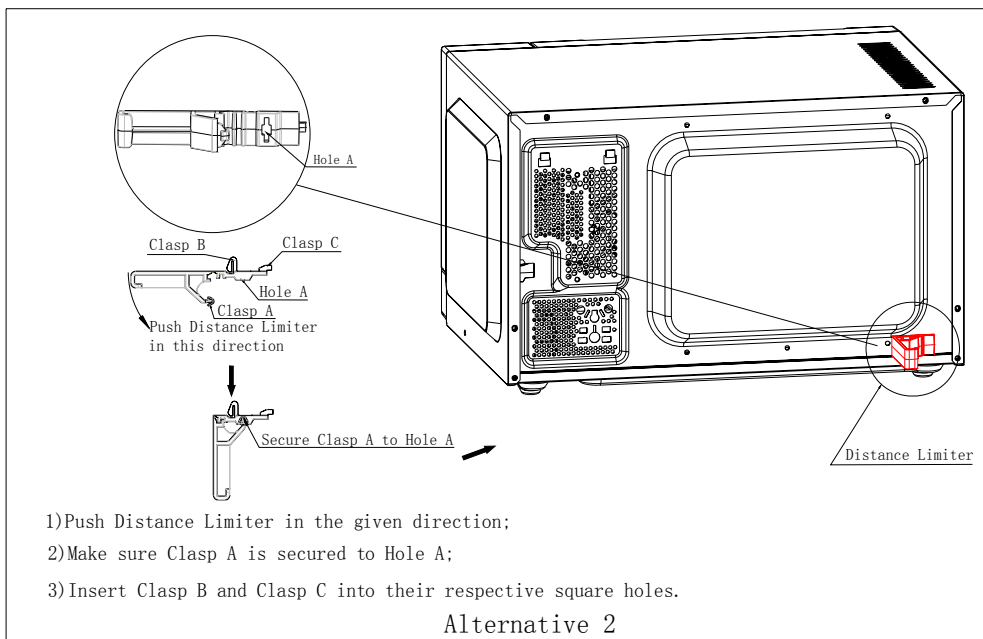
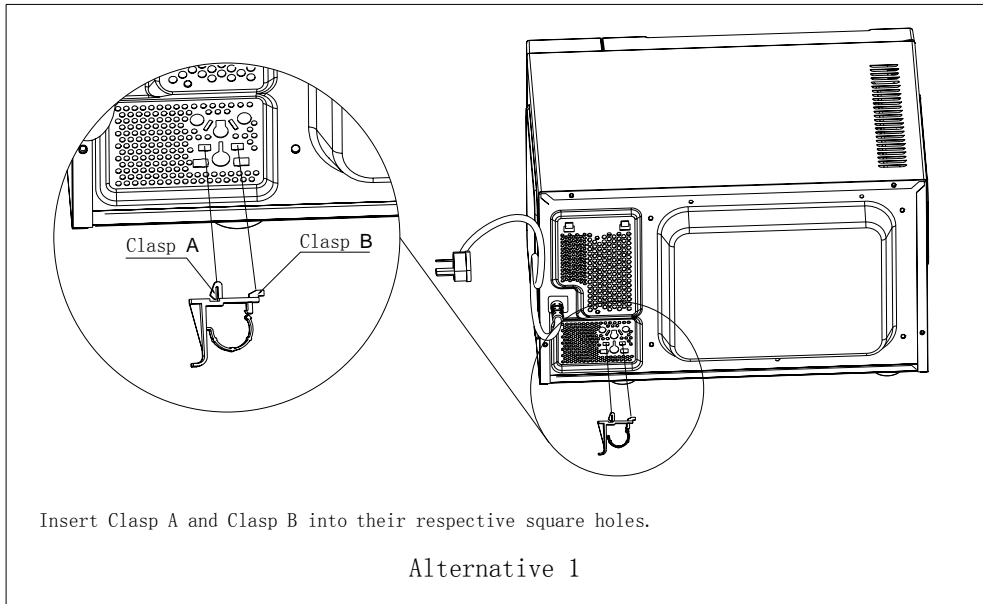

## UTENSILS GUIDELINE

Before use, check whether the utensils used are suitable for cooking in this microwave oven. Please take the table below for your reference. In the table, “o” means applicable while “X” not applicable.

Material of container	Microwave
Heat-resistant glass	o
Ceramic	o
Ordinary glass	X
Heat-resistant plastic	o

Ordinary plastic	X
Thin Plastic film	o
Metal Grill	X
Metal container	X

## FOR THE FIRST USE

As there is manufacturing residue or oil remained on the oven cavity or heat element, it usually would smell the odor, even a slight smoke. It is a normal case and would not occur after several times use, keep the door or window open to ensure good ventilation. So it is strongly recommended to place a cup of water in the turntable and set at high power and operate for several times

## Household use only

### PRODUCT INSTRUCTION

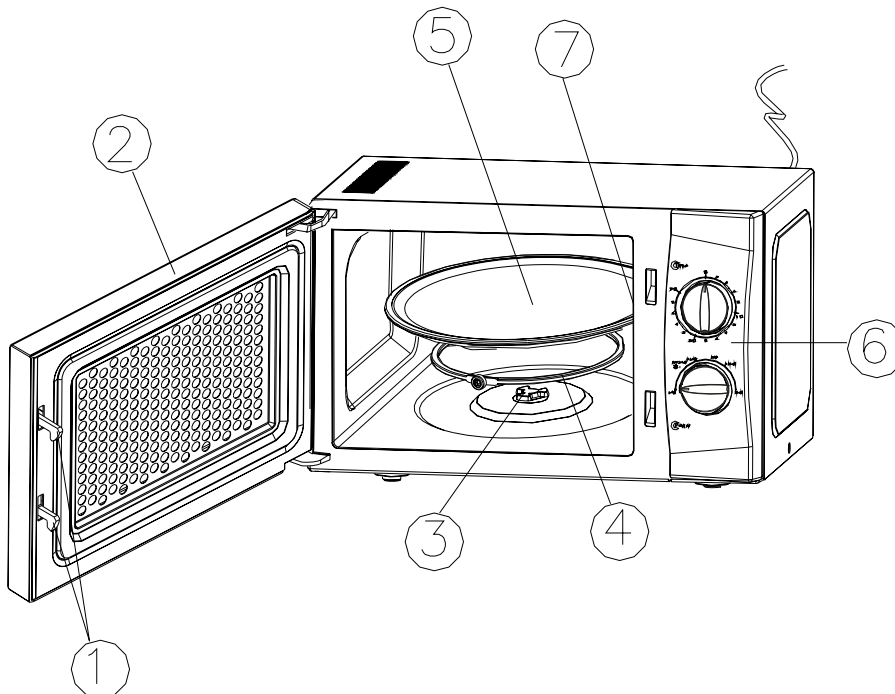

- 1) Door interlock Ensure that microwave oven can only be activated when the door is properly closed.
- 2) Viewing Window Cooking status can be viewed through metal mesh.
- 3) Rotating axis Drive the glass turntable rotating
- 4) Rotating ring Support the glass turntable
- 5) Turntable It turns to make food heated evenly when cooking, recommend using it when cooking.
- 6) Control panel See below in details (the control panel is subject to change without prior notice)
- 7) Wave guide cover (inside) **WARNING:** Never remove it during cleaning. See fig.1

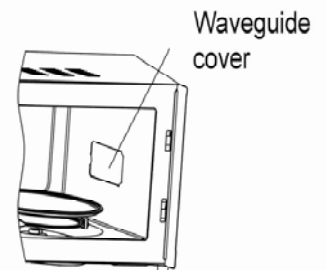

Fig.1

## **IMPORTANT SAFEGUARDS**

The following basic precautions should always be followed when using electrical appliance:

1. Read all instructions before using.
2. Make sure the voltage in your living area corresponding to the one shown on the rating label of the appliance. And the wall socket is properly grounded.
3. To reduce the risk of fire in the oven cavity:
  - a. Do not overcook the food.
  - b. Remove wire twist-ties from paper or plastic bags before placing bags in the oven.
  - c. Do not heat oil or fat for deep drying as the temperature of oil cannot be controlled.
  - d. After use wipe the waveguide cover with a damp cloth, followed by dry cloth to remove any food splashes and grease. Built-up grease may overheat and begin to cause smoke or catch fire.
  - e. If materials inside the oven should smoke or ignite, keep oven door closed, turn oven off and disconnect the power supply.
  - f. Close supervision is necessary when using disposable containers made from plastic, paper or other combustible material.
4. To reduce the risk of explosion and sudden boiling:
  - a. Do not place sealed containers in the oven. Baby bottles fitted with a screw cap or teat are considered to be sealed containers.
  - b. When boiling liquid in the oven, use the wide-mouthed container and stand about 20 seconds at the end of cooking to avoid delayed eruptive boiling of liquids.
  - c. Potatoes, sausage and chestnut should be peeled or pierced before cooking. Eggs in their shell, whole hard-boiled eggs should not be heated in microwave ovens since they may explode, even after microwave heating has ended.
  - d. The cooked liquid should not be removed out immediately. Several moments should be waited before removing In order to avoid possible hazards caused by delayed eruptive boiling of liquids.
  - e. The contents of feeding bottles and baby food jars are to be stirred or shaken and the temperature is to be checked before consumption, in order to avoid burns.
5. Never operate the oven further if the door or door seals are damaged or the oven is malfunctioned or supply cord is damaged. Return the appliance to the nearest authorized service center for repair and maintenance. Never try to adjust or repair the oven yourself.
6. If the supply cord is damaged it must be replaced by the manufacturer or its service agent or a qualified technician in order to avoid a shock hazard.
7. After cooking, the container is very hot. Using gloves to take out the food and avoid steam burns by directing steam away from the face and hands.
8. Slowly lift the furthest edge of dishes cover and microwave plastic wrap and carefully open popcorn and oven cooking bags away from the face.
9. To prevent the turntable from breaking:
  - a. Let the turntable cool down before cleaning.
  - b. Do not place hot foods or utensils on the cold turntable.
  - c. Do not place frozen foods or utensils on the hot turntable.
10. Make sure the utensils do not touch the interior walls during cooking.
11. Failure to maintain the oven in a clean condition could lead to deterioration of the surface that could adversely affect the life of the appliance and possibly result in a hazardous situation.

12. Only use utensils that are suitable for use in microwave ovens.
13. Do not store food or any other things inside the oven.
14. Do not operate the oven without any liquid or food inside the oven. This would do damage the oven.
15. This appliance is not intended for using by young children or infirm persons without supervision.
16. Any accessories not recommended by the manufacturer may cause injuries to persons.
17. Do not use outdoors.
18. Save these instructions.
19. This appliance is not intended for used by persons (including children) with reduced physical, sensory or mental capabilities, or lack of experience and knowledge, unless they have been given supervision or instruction concerning use of the appliances by a person responsible for their safety.  
Children should be supervised to ensure that they do not play with the appliance.

## CONTROL PANEL

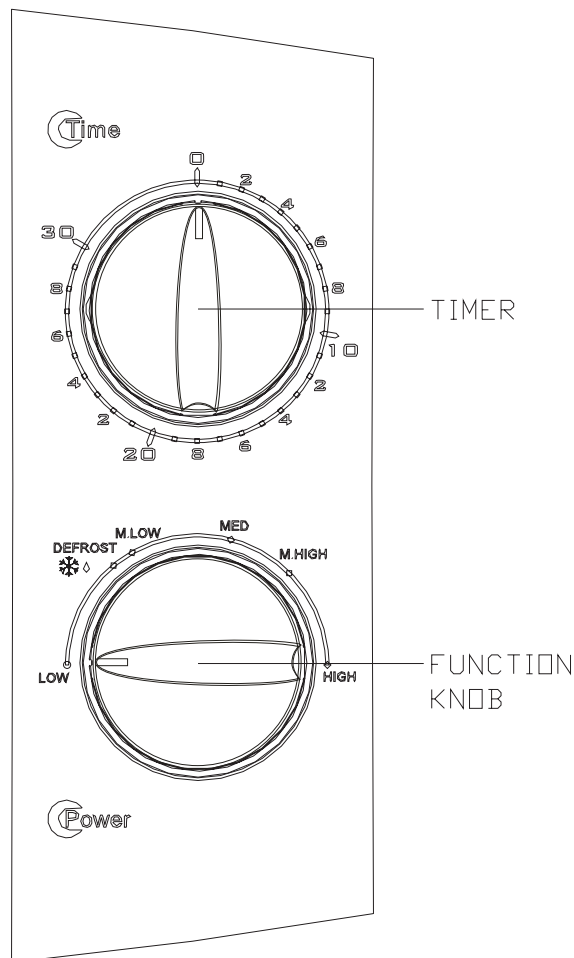

### 1、Timer

The max length could be set is 30 minutes, and a bell prompt will be heard at zero position.

## 2、 Function knob

Six power level options for microwave cooking:

- 1) HIGH: 100% power input (suitable for quick cooking)
- 2) M. HIGH: 85% power input (suitable for roasting)
- 3) MED: 66% power input (suitable for slow cooking)
- 4) M.LOW: 40% power input
- 5) DEFROST: 37% power input
- 6) LOW: 17% power input (suitable for keeping warm)

## OPERATION

1. Connect the cord.
2. Place the food on the glass turntable and close the door.
3. Select your desired function menu
4. Set the timer. If your set time is less than 2 minutes, first turn the timer to over 3 minutes position and then turn back to your desired time.
5. Then the oven begins to work. Make the cooking pause by opening the door at any time and close the door to continue.
6. A bell ring will be heard after time out. And the oven is de-energized and the lamp will be off.

**Caution: If food is removed before time out, make sure the timer is set back to "0" position so as to avoid unintentional running without load.**

## DEFROST NOTES

Defrosting frozen food is one of utilities of microwave oven, it is more acceptable with a reduced risk of deleterious bacteria than normal defrost.

- 1、 Turn the function knob to Defrost position.
- 2、 Set the timer by the food to defrost. It usually required longer time than ordinary cooking. Turn the food one time or more to check the doneness. Take the food for good if it could be easily cut by a knife.

**Note: Microwave have a food penetrability of 4cm each side. To maximize defrosting effect of thick and chunky food, it is necessary to turn over the food constantly and remove out the defrosted portion or thin parts.**

### Defrost guide

#### Steak chops

- Shield thin end of chops or steaks with foil.
- Position the food with thinner parts in the center in a single layer on a shallow dish. If pieces are stuck together, try to separate as soon as possible.
- Turn over the food in the middle course. Then rearrange and shield the defrosted portions.
- Close the door to continue defrosting.
- After defrost time, stand covered with aluminum foil for 5-15 minutes.

#### Minced Beef

- Place frozen minced beef on a shallow dish. Shield edges.
- Turn over the food in the middle course. Remove defrosted portions, turn over and shield edges with foil strips.
- Close the door to continue defrosting.

- After defrost time, stand covered with aluminum foil for 5-15 minutes.

#### **Roast Meat (Beef/pork/lamb)**

- Shield the edges with foil strips.
- Place joint with lean side face upwards (if possible) on a shallow dish.
- turn over the food in the middle course. And then shield the defrosted portions.
- Close the door to continue defrosting.
- After defrost time, stand covered with aluminum foil for 10-30 minutes.

#### **Poultry**

- Remove from original wrapper. Shield wing and leg tips with foil.
- Place breast side down on a shallow dish.
- turn over the food in the middle course. And then shield the defrosted portions.
- Close the door to continue defrosting.
- After defrost time, stand covered with aluminium foil for 15-30 minutes.

**Note:** After standing run under cold water to remove giblets if necessary.

#### **Chicken pieces ( chicken wings and drumstick)**

- shield the exposed bone with foil.
- Place chicken pieces on a shallow dish.
- turn over the food in the middle course. And then rearrange and shield the defrosted portions.
- Close the door to continue defrosting.
- After defrost time, stand covered with aluminum foil for 5-30 minutes.

## **CLEANING & MAINTENANCE**

The oven should be cleaned regularly and any food deposits removed.

Suggest you perform below steps after every time use.

Never use hard detergent, gasoline, abrasive powder or metal brush to clean any part of the appliance.

Clean the oven at regular intervals

Disconnect the power supply cord before cleaning. And if possible leave the door open to inactive the oven during cleaning.

Remove rotating ring, glass turntable out and wash them in warm soapy water.

Use a wet soft cloth to wipe the outer and inner wall of the door, cavity and control panel.

If the oil or soup splashed on the wall of cavity, it must be cleaned otherwise smoke may occur in next use.

If the cavity emit odor, following 3 methods can get rid of them:

Place several lemon slices in a cup, then heat them with high power for 2-3 minutes.

Place a cup of red tea in oven, then heat it with high power.

Put some orange peels into oven, then heat them with high power for 1 minute.

Dry all parts thoroughly and replace them.

## **SERVICING**

**Warning:** It is hazardous for anyone, other than a qualified service technician, to carry out any service for repairing operation which involves removal of any cover which gives protection against exposure to microwave energy.

**Caution: MICROWAVE RADIATION**



**Do not become exposed to radiation from the microwave generator or other parts conducting microwave energy.**

**During servicing below listed parts are liable to be removed and give access to potentials above 250V to earth.**

- 1. Magnetron**
- 2. High voltage transformer**
- 3. High voltage capacitor**
- 4. High voltage Diode**
- 5. High voltage fuse**

**The following conditions may cause undue microwave exposure during servicing.**

**Improper fitting of magnetron.**

**Improper matching of door interlock, door hinge and door.**

**Improper fitting of switch support.**

**Door, door seal or enclosure has been damaged.**

### **Cooking Tips**

**1) Arrange food carefully, place thickest areas toward outside of dish.**

**2) Watch cooking time, cook for the shortest amount of time indicated and add more time as needed.**

**3) Cover foods before cooking**

**check recipe for suggestions: paper towels, microwave plastic wrap or a lid.**

**Covers prevent spattering and help foods to cook evenly. (Helps keep oven clean).**

**4) Shield foods**

**Use small pieces of aluminum foil to cover thin areas of meats or poultry to avoid overcooking.**

**5) Stir foods**

**From outside to center of dish once or twice during cooking, if possible.**

**6) Turn foods**

**Foods such as chicken, hamburgers or steaks should be turned over once during cooking.**

**7) Rearrange foods**

**Like meatballs halfway through cooking both from top to bottom and from the center of the dish to the outside.**

**8) Allow standing time**

**Heated liquid or beverage may result in delayed eruptive boiling. After cooking ensure adequate standing time.**

**Remove food from oven and stir if possible.**

**Cover for standing time which allows the food to finish cooking without overcooking.**

**8) Check for doneness**

**Look for signs indicating that cooking temperature has been reached. Doneness signs include:**

**-Food steams throughout, not just at edge.**

**-Poultry thigh joints move easily.**

**-Pork and poultry show no pinkness..**

**-Fish is opaque and flakes easily with a fork.**

**9) Condensation**

**A normal part of microwave cooking. The humidity and moisture in food will influence the amount of moisture in the oven. Generally, covered foods will not cause as much condensation as uncovered foods. Ensure that the ventilation openings are not blocked.**

**10) Browning dish**

**when using a browning dish or self-heating material, always place a heat-resistant insulator such**

as a porcelain plate under it to prevent damage to the turntable, rotating ring due to heat stress. The preheating time specified in the dishes instructions must not be exceeded.

**11) Microwave safe plastic wrap**

for cooking food with high fat content, do not bring the wrap in contact with the food as it may melt.

**12) Microwave safe plastic cookware**

Some microwave safe plastic cookware are not suitable for cooking foods with high fat and sugar content.

**13) Liquid and similar food must not be cooked in sealed containers since they are liable to explode.**

**14) Eggs in the shell, whole hard-boiled eggs, potatoes, sausage must be pierced or peeled before cooking otherwise they may explode.**

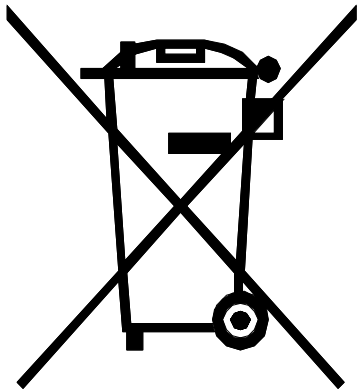

**DISPOSAL:** Do not dispose this product as unsorted municipal waste, collection of such waste separately for special treatment is necessary.