

Lynx™ L-3X



DEALER: This manual **MUST** be given to the user of the scooter.

USER: **BEFORE** using this scooter, read this manual and save for future reference.

For more information regarding
Invacare products, parts, and services,
please visit www.invacare.com



Yes, you can.®

⚠ WARNING

Procedures other than those described in this manual must be performed by a Qualified technician.

DO NOT use this product or any available optional equipment without first completely reading and understanding these instructions and any additional instructional material such as owner's manuals, service manuals or instruction sheets supplied with this product or optional equipment. If you are unable to understand the warnings, cautions or instructions, contact a healthcare professional, dealer or technical personnel before attempting to use this equipment - otherwise, injury or damage may occur.

⚠ ACCESSORIES WARNING

Invacare products are specifically designed and manufactured for use in conjunction with Invacare accessories. Accessories designed by other manufacturers have not been tested by Invacare and are not recommended for use with Invacare products.

NOTE: Updated versions of this manual are available on www.invacare.com.

TABLE OF CONTENTS

REGISTER YOUR PRODUCT	4
SPECIAL NOTES	5
LABEL LOCATIONS	7
TYPICAL PRODUCT PARAMETERS	8
SECTION 1—GENERAL GUIDELINES	9
Repair or Service Information	9
Operation Information	9
Electrical	11
Batteries	12
Rain Test	12
Weight Training	12
Weight Limitation	12
SECTION 2—EMI INFORMATION	13
SECTION 3—SAFETY/HANDLING OF POWERED SCOOTERS	15
Stability and Balance	15
Stairways	16
Escalators	16
SECTION 4—SAFETY INSPECTION	17
Safety Inspection Checklists	17
SECTION 5—MAINTENANCE AND TROUBLESHOOTING	20
Suggested Maintenance Procedures	20
Troubleshooting	21
Service Indicator Error Codes	22
SECTION 6—OPERATION OF THE POWERED SCOOTER	23
Control Panel	23
Operating the Scooter	24
Engaging/Disengaging the Brake Release Lever	26
SECTION 7—SEAT AND ARMS	27
Removing/Installing the Seat	27
Adjusting Seat Height	28
Adjusting 90° Seat Swivel	29
Adjusting the Seat Slide	29
Adjusting the Arm Width	30
Replacing Armrest Pads	30

TABLE OF CONTENTS

SECTION 8—TILLER ADJUSTMENT	31
Adjusting the Tiller Angle	31
SECTION 9—WHEELS AND CASTERS	32
Removing/Installing the Drive Wheels	32
Removing/Installing the Front Wheel	33
SECTION 10—BATTERIES	34
Recommended Battery Type	34
Removing/Installing the Batteries	35
Connecting/Disconnecting the Battery Cables	37
Charging the Batteries	40
SECTION 11—TRANSPORTING	42
Transporting the Scooter	42
SECTION 12—ACCESSORIES	44
Installing/Removing the Crutch/Cane Holder	44
Installing/Removing the Safety Flag	45
Installing/Removing/Using the Walker Holder	45
Installing/Removing the Rear Mounted Basket	47
LIMITED WARRANTY	48

REGISTER YOUR PRODUCT

The benefits of registering include:

1. Safeguarding your investment.
2. Ensuring long-term maintenance and servicing of your product.
3. Receiving updates with product information, maintenance tips and industry news.

Register ONLINE at warranty.invacare.com

Please have your model number and purchase date available to complete your registration.

Any registration information you submit will only be used by Invacare Corporation and protected as required by applicable laws and regulations.

SPECIAL NOTES

Signal words are used in this manual and apply to hazards or unsafe practices which could result in personal injury or property damage. Refer to the table below for definitions of the signal words.

SIGNAL WORD	MEANING
DANGER	Danger indicates an imminently hazardous situation which, if not avoided, will result in death or serious injury.
WARNING	Warning indicates a potentially hazardous situation which, if not avoided, could result in death or serious injury.
CAUTION	Caution indicates a potentially hazardous situation which, if not avoided, may result in property damage.

NOTICE

THE INFORMATION CONTAINED IN THIS DOCUMENT IS SUBJECT TO CHANGE WITHOUT NOTICE.

As a distributor of powered scooters, Invacare endeavors to supply a wide variety of powered scooters to meet many needs of the end user. However, final selection of the type of powered scooter to be used by an individual rests solely with the user and his/her healthcare professional capable of making such a selection.

TIE-DOWN RESTRAINTS AND SEAT RESTRAINTS

Powered scooter users should **NOT** be transported in vehicles of any kind while in the powered scooter. As of this date, the Department of Transportation has not approved any tie-down systems for transportation of a user while in a powered scooter, in a moving vehicle of any type.

It is Invacare's position that users of powered scooters should be transferred into appropriate seating in vehicles for transportation and use be made of the restraints made available by the auto industry. Invacare cannot and does not recommend any powered scooter transportation systems.

⚠ WARNING

Invacare products are specifically designed and manufactured for use in conjunction with Invacare accessories. Accessories designed by other manufacturers have not been tested by Invacare and are not recommended for use with Invacare products.

Scooters should be examined during maintenance for signs of corrosion (water exposure, incontinence, etc.). Electrical components damaged by corrosion should be replaced IMMEDIATELY.

Scooters that are used by incontinent users and/or are frequently exposed to water may require replacement of electrical components more frequently.

LABEL LOCATIONS



WEIGHT CAPACITY
300 LBS. (136 kgs.)
 REFER TO OWNER'S MANUAL
P/N 1111016

⚠ WARNING
 Ensure that seat lock lever is locked. Refer to Owner's Manual.
P/N 1125058

⚠ WARNING ⚠
 DO NOT operate the scooter unless the tiller is in the locked position.
 DO NOT lean against or pull forward on the tiller while mounting or dismounting the scooter. Otherwise, injury may occur.
 DO NOT lift scooter up by the front or rear shroud. Otherwise injury or damage to the scooter may occur.
1118373 Rev A

Serial
 Number
 Label

NOTE: The battery wiring label is on the underside of the battery box lid.

⚠ WARNING DO NOT REMOVE THIS LABEL.

The POSITIVE (+) RED battery cable MUST connect to the POSITIVE (+) battery terminal. The NEGATIVE (-) BLACK battery cable MUST connect to the NEGATIVE (-) battery terminal. DO NOT allow battery cables to contact the opposite battery terminal. Replace cables IMMEDIATELY if cable insulation becomes damaged. Failure to observe these warnings may result in an electrical short with serious personal injury and/or damage to the electrical system. See Owner's Manual. P/N 1148111 REV A - 03/30/07

TYPICAL PRODUCT PARAMETERS

	LYNX L-3X
OVERALL DIMENSIONS	
BASE LENGTH:	44 inches
BASE WIDTH:	21.5 inches
STEP HEIGHT (Floor Pan to Ground):	5 inches
SEAT HEIGHT (Floor Pan to Seat Cushion):	16 inches
OVERALL HEIGHT	36 inches
SEAT DIMENSIONS	
WIDTH:	18 inches
DEPTH:	16 inches
BACK HEIGHT:	13.5 inches
ARM DIMENSIONS	
LENGTH:	11.25 inches
HEIGHT BETWEEN SEAT AND ARMS:	7 inches
WIDTH BETWEEN ARMS:	17 - 24 inches
SPEED RANGE	0 - 5 m.p.h.
WHEELS	
FRONT WHEEL:	8 inches x 2 inches
DRIVE WHEEL:	9 inches x 2 inches
TURNING RADIUS:	44.7 inches
WEIGHT OF PRODUCT:	
FRONT BASE SECTION:	30 lbs
REAR BASE SECTION:	43 lbs
BATTERIES:	56 lbs
SEAT:	28 lbs
BASKET:	1 lb
TOTAL WEIGHT OF PRODUCT:	158 lbs
MAXIMUM WEIGHT LIMITATION	300 lbs

SECTION I—GENERAL GUIDELINES

⚠ WARNING

SECTION I - GENERAL GUIDELINES contains important information for the safe operation and use of this product.

Repair or Service Information

Set-up of the Electronics Control Unit is to be performed only by a qualified technician. The final adjustments of the controller may affect other activities of the scooter. Damage to the equipment could occur if improperly set-up or adjusted.

DO NOT service or adjust your powered scooter while occupied, unless otherwise noted.

Scooters should be examined during maintenance for signs of corrosion (water exposure, incontinence, etc.). Electrical components damaged by corrosion should be replaced IMMEDIATELY.

Scooters that are used by incontinent users and/or are frequently exposed to water may require replacement of electrical components more frequently.

Operation Information

Invacare products are specifically designed and manufactured for use in conjunction with Invacare accessories. Accessories designed by other manufacturers have not been tested by Invacare and are not recommended for use with Invacare products.

Performance adjustments should only be made by professionals of the healthcare field or persons fully conversant with this process and the driver's capabilities. Incorrect settings could cause injury to the driver, bystanders and damage to the scooter and to surrounding property.

ALWAYS wear your seat positioning strap. Inasmuch as the seat positioning strap is an option on this scooter (you may order with or without the seat positioning strap), Invacare strongly recommends ordering the seat positioning strap as an additional safeguard for the scooter user. The seat positioning strap is a positioning belt only. It is not designed for use as a safety device withstanding high stress loads such as auto or aircraft safety belts. If signs of wear appear, belt must be replaced immediately.

Before using the scooter, verify that the motor is plugged into the harness.

DO NOT connect any medical devices such as ventilators, life support machines, etc., to the battery. This could cause unexpected failure of the device and the powered scooter.

DO NOT operate the powered scooter until you have checked that the surroundings are clear and that the area is safe for travel.

DO NOT make sharp turns in the forward or reverse direction at excessive speed. Failure to observe the warning can cause the scooter to tip over and may result in injury to user and/or damage to the product.

DO NOT operate on roads, streets or highways.

DO NOT attempt to move up or down an incline with water, ice or oil film.

Avoid operating the scooter in dark or poorly lit areas.

DO NOT climb and/or go up or down ramps or traverse slopes greater than 8°.

When negotiating ramps, if the throttle control lever is released while in the forward motion, the powered scooter will roll back approximately one foot before the brake engages. If the throttle control lever is released while in the reverse motion, the powered scooter will roll back approximately three feet before the brake engages.

DO NOT attempt to drive over curbs or obstacles. Doing so may cause your powered scooter to turn over and cause bodily harm and/or damage to the scooter.

DO NOT use an escalator to move a powered scooter between floors. Serious bodily injury may occur.

Powered scooter with batteries and seat weighs 158 lbs. Use proper lifting techniques (lift with your legs) to avoid injury.

Before attempting to sit in or exit the powered scooter, remove the key from the ignition. This will ensure that the power is off and the powered scooter will not drive.

DO NOT remove the key or shut off while the powered scooter is in motion.

Remove the key from the ignition while the powered scooter is not in use so as to avoid injury and/or damage to the scooter and surrounding areas.

DO NOT attempt to lift the powered scooter by any removable (detachable) parts. Lifting by means of any removable (detachable) parts of a powered scooter may result in injury to the user or damage to the powered scooter.

DO NOT attempt to lift the powered scooter by its tiller, seat or shrouds.

DO NOT stand on the frame of the powered scooter.

DO NOT stand on the shroud(s) of the powered scooter.

DO NOT operate the powered scooter without the rear shroud installed, to avoid injury and/or damage to scooter.

Before use, ensure that the front frame assembly properly engages the rear frame assembly pins and that the release lever is locked. Otherwise, injury and/or damage may result.

DO NOT attempt to reach objects if you have to move forward in the seat or pick them up from the floor by reaching between your knees.

DO NOT lean over the top of the back upholstery to reach objects behind you, as this may cause the powered scooter to tip over.

DO NOT shift your weight or sitting position toward the direction you are reaching as the powered scooter may tip over.

Determine and establish your particular safety limits by practicing bending, reaching and transferring activities in the presence of a qualified healthcare professional before attempting active use of the powered scooter.

For individuals with balance problems, DO NOT attempt to transfer into or out of the powered scooter without assistance. Practice transferring activities with an assistant in the presence of a qualified healthcare professional.

Ensure that the seat is properly locked before use. Otherwise the user may fall from the scooter resulting in bodily harm. Attempting unsafe transfers may cause the user to fall, resulting in serious injury.

Ensure that the seat is locked in the forward position before and during the operation of the scooter. Otherwise, injury to the user and/or damage to the scooter may result.

Ensure that the tiller is properly adjusted before driving the scooter.

After making any tiller angle adjustment and before use, the tiller must be securely locked into position. Otherwise the user may fall from the scooter resulting in bodily harm and/or damage to the scooter. Gently push/pull the tiller to ensure that the tiller is securely engaged.

DO NOT overtighten hardware attaching to the frame. This could cause damage to the frame tubing.

ALWAYS keep hands and fingers clear of moving parts to avoid injury.

ALWAYS check hand grips for looseness before using the powered scooter. If loose and/or worn, replace immediately.

If scooter is exposed to extreme temperature (above 100°F or below 32°F), high humidity and/or becomes wet, prior to use, ensure handgrips DO NOT twist on scooter handles. Otherwise, damage or injury may occur.

Avoid storing or using the scooter near open flame or combustible products. Serious injury or damage to property may result.

Never leave an unoccupied scooter on an incline.

ALWAYS use anti-tippers. When outdoors on wet, soft ground or on gravel surfaces, anti-tippers may not provide the same level of protection against tip over. Extra caution MUST be observed when traversing such surfaces.

Electrical

Check to ensure that all electrical connections are secure at all times.

Grounding Instructions

DO NOT, under any circumstances, cut or remove the round grounding prong from any plug used with or for Invacare products. Some devices are equipped with three-prong (grounding) plugs for protection against possible shock hazards. Where a two-prong wall receptacle is encountered, it is the personal responsibility and obligation of the customer to contact a qualified electrician and have the two-prong receptacle replaced with a properly grounded three-prong wall receptacle in accordance with the National Electrical Code. If you must use an extension cord, use ONLY a three-wire extension cord having the same or higher electrical rating as the device being connected. In addition, Invacare has placed RED/ORANGE warning tags on some equipment. DO NOT remove these tags.

Batteries

The warranty and performance specifications contained in this manual are based on the use of deep cycle gel cell batteries. Invacare strongly recommends their use as the power source for this unit.

Carefully read battery/battery charger information prior to installing, servicing or operating your powered scooter.

Rain Test

Invacare has tested its powered scooters in accordance with ISO 7176 “Rain Test”. This provides the end user or his/her attendant sufficient time to remove his/her power powered scooter from a rain storm and retain powered scooter operation.

DO NOT leave the powered scooter in a rain storm of any kind.

DO NOT use the powered scooter in a shower.

DO NOT leave the powered scooter in a damp area for any length of time.

Direct exposure to rain or dampness will cause the scooter to malfunction electrically and mechanically; may cause the powered scooter to prematurely rust.

Check to ensure that all electrical connections are secure at all times.

Weight Training

Invacare does not recommend the use of its powered scooters as a weight training apparatus. Invacare powered scooters have not been designed or tested as a seat for any kind of weight training. If occupant uses said powered scooter as a weight training apparatus, Invacare shall not be liable for bodily injury and the warranty is void.

Weight Limitation

The weight limitation is 300 lbs.

SECTION 2—EMI INFORMATION

⚠ WARNING

CAUTION: IT IS VERY IMPORTANT THAT YOU READ THIS INFORMATION REGARDING THE POSSIBLE EFFECTS OF ELECTROMAGNETIC INTERFERENCE ON YOUR POWERED WHEELCHAIR.

Electromagnetic Interference (EMI) From Radio Wave Sources

Powered wheelchairs and motorized scooters (in this text, both will be referred to as powered wheelchairs) may be susceptible to electromagnetic interference (EMI), which is interfering electromagnetic energy (EM) emitted from sources such as radio stations, TV stations, amateur radio (HAM) transmitters, two way radios, and cellular phones. The interference (from radio wave sources) can cause the powered wheelchair to release its brakes, move by itself, or move in unintended directions. It can also permanently damage the powered wheelchair's control system. The intensity of the interfering EM energy can be measured in volts per meter (V/m). Each powered wheelchair can resist EMI up to a certain intensity. This is called its "immunity level." The higher the immunity level, the greater the protection. At this time, current technology is capable of achieving at least a 20 V/m immunity level, which would provide useful protection from the more common sources of radiated EMI.

There are a number of sources of relatively intense electromagnetic fields in the everyday environment. Some of these sources are obvious and easy to avoid. Others are not apparent and exposure is unavoidable. However, we believe that by following the warnings listed below, your risk to EMI will be minimized.

The sources of radiated EMI can be broadly classified into three types:

- 1) Hand-held Portable transceivers (transmitters-receivers with the antenna mounted directly on the transmitting unit. Examples include: citizens band (CB) radios, "walkie talkie", security, fire and police transceivers, cellular telephones, and other personal communication devices).

NOTE: Some cellular telephones and similar devices transmit signals while they are ON, even when not being used.

- 2) Medium-range mobile transceivers, such as those used in police cars, fire trucks, ambulances and taxis. These usually have the antenna mounted on the outside of the vehicle; and
- 3) Long-range transmitters and transceivers, such as commercial broadcast transmitters (radio and TV broadcast antenna towers) and amateur (HAM) radios.

NOTE: Other types of hand-held devices, such as cordless phones, laptop computers, AM/FM radios, TV sets, CD players, cassette players, and small appliances, such as electric shavers and hair dryers, so far as we know, are not likely to cause EMI problems to your powered wheelchair.

⚠ WARNING

Powered Wheelchair Electromagnetic Interference (EMI)

Because EM energy rapidly becomes more intense as one moves closer to the transmitting antenna (source), the EM fields from hand-held radio wave sources (transceivers) are of special concern. It is possible to unintentionally bring high levels of EM energy very close to the powered wheelchair's control system while using these devices. This can affect powered wheelchair movement and braking. Therefore, the warnings listed below are recommended to prevent possible interference with the control system of the powered wheelchair.

Electromagnetic interference (EMI) from sources such as radio and TV stations, amateur radio (HAM) transmitters, two-way radios, and cellular phones can affect powered wheelchairs and motorized scooters.

FOLLOWING THE WARNINGS LISTED BELOW SHOULD REDUCE THE CHANCE OF UNINTENDED BRAKE RELEASE OR POWERED WHEELCHAIR MOVEMENT WHICH COULD RESULT IN SERIOUS INJURY.

- 1) Do not operate hand-held transceivers (transmitters receivers), such as citizens band (CB) radios, or turn ON personal communication devices, such as cellular phones, while the powered wheelchair is turned ON;
- 2) Be aware of nearby transmitters, such as radio or TV stations, and try to avoid coming close to them;
- 3) If unintended movement or brake release occurs, turn the powered wheelchair OFF as soon as it is safe;
- 4) Be aware that adding accessories or components, or modifying the powered wheelchair, may make it more susceptible to EMI (NOTE: There is no easy way to evaluate their effect on the overall immunity of the powered wheelchair); and
- 5) Report all incidents of unintended movement or brake release to the powered wheelchair manufacturer, and note whether there is a source of EMI nearby.

Important Information

- 1) 20 volts per meter (V/m) is a generally achievable and useful immunity level against EMI (as of May 1994) (the higher the level, the greater the protection);
- 2) This device has been tested to a radiated immunity level of 20 volts per meter.
- 3) The immunity level of the product is unknown.

Modification of any kind to the electronics of this scooter as manufactured by Invacare may adversely affect the EMI immunity levels.

SECTION 3—SAFETY/HANDLING OF POWERED SCOOTERS

“Safety and Handling” of the powered scooter requires the close attention of the user. This manual points out the most common procedures and techniques involved in the safe operation and maintenance. It is important to practice and master these safe techniques until you are comfortable in maneuvering the powered scooter.

Use this information only as a “basic” guide. The techniques that are discussed have been used successfully by many. Individual users often develop skills to deal with daily living activities that may differ from those described in this manual. Invacare recognizes and encourages each individual to try what works best for him/her in overcoming obstacles that they may encounter; however, all warnings and cautions given in this manual **MUST** be followed. Techniques in this manual are a starting point for the new powered scooter user with “safety” as the most important consideration for all.

Stability and Balance

⚠ WARNING

DO NOT make sharp turns in the forward or reverse direction at excessive speed. Failure to observe the warning can cause the scooter to tip over and may result in injury to user and/ or damage to the product.

ALWAYS wear your seat positioning strap. Inasmuch as the seat positioning strap is an option on this scooter (you may order with or without the seat positioning strap), Invacare strongly recommends ordering the seat positioning strap as an additional safeguard for the scooter user. The seat positioning strap is a positioning belt only. It is not designed for use as a safety device withstanding high stress loads such as auto or aircraft safety belts. If signs of wear appear, belt **MUST** be replaced immediately.

DO NOT attempt to reach objects if you have to move forward in the seat or pick them up from the floor by reaching down between your knees.

Be aware that carrying heavy objects on your lap while occupying the scooter may adversely affect the stability of the scooter, resulting in serious bodily injury to the user, damage to the scooter and surrounding property.

This scooter has been designed to accommodate one individual. If more than one individual occupies the scooter this may adversely affect the stability of the scooter, resulting in serious bodily injury to the user and passenger and damage to the scooter and surrounding property.

To assure stability and proper operation of your powered scooter, you **MUST**, at all times, maintain proper balance. Your powered scooter has been designed to remain upright and stable during normal daily activities.

Many activities require the scooter owner to reach, bend and transfer in and out of the powered scooter. These movements cause a change to the normal balance, the center of gravity, and the weight distribution of the powered scooter. To determine and establish your particular safety limits, practice bending, reaching and transferring activities in several combinations in the presence of a qualified healthcare professional before attempting active use of the scooter. Proper positioning is essential for your safety.

Stairways

WARNING

DO NOT attempt to move an occupied powered scooter between floors using a stairway. Use an elevator to move an occupied powered scooter between floors.

If moving a powered scooter between floors by means of a stairway, the occupant **MUST** be removed and transported independently of the powered scooter. Extreme caution is advised when moving an unoccupied powered scooter up or down the stairs. Invacare recommends disassembling the scooter and transporting the components independently up or down the stairs. **ONLY** use secure, non-detachable parts on each component for hand-hold supports.

DO NOT attempt to lift a powered scooter by any removable (detachable) parts. Lifting by means of removable (detachable) parts may result in injury to the user or assistants or damage to the powered scooter.

Escalators

WARNING

DO NOT use an escalator to move a powered scooter between floors. Serious bodily injury may occur.

Powered scooter without the batteries can weigh between 80 and 89 lbs. Use proper lifting techniques (lift with your legs) to avoid injury.

Follow this procedure for moving the powered scooter between floors when an elevator is not available:

1. Remove the occupant from the powered scooter.
2. Disassemble the scooter. Refer to [Transporting the Scooter](#) on page 42.
3. Carefully move the powered scooter components up or down the stairway.
4. Once all the components of the scooter are transported to the desired location reassemble the scooter. Refer to [Transporting the Scooter](#) on page 42.

SECTION 4—SAFETY INSPECTION

NOTE: Every six months take your powered scooter to a qualified technician for a thorough inspection and servicing. Regular cleaning will reveal loose or worn parts and enhance the smooth operation of your powered scooter. To operate properly and safely, your powered scooter must be cared for just like any other vehicle. Routine maintenance will extend the life and efficiency of your powered scooter.

⚠ WARNING

Before performing any maintenance, adjustment or service, turn power Off and remove key from ignition.

CAUTION

As with any vehicle, the wheels and tires should be checked periodically for cracks and wear, and should be replaced.

Safety Inspection Checklists

Initial adjustments should be made to suit your personal body structure needs and preference. Thereafter follow these maintenance procedures:

Inspect/Adjust Initially

- Ensure powered scooter drives straight (no excessive drag or pull to one side).
- Check frame for damage and corrosion.
- Ensure that the brake release lever is easy to engage/disengage.
- Ensure that tiller adjustment mechanism engages and disengages properly and securely.
- Ensure that the scooter stops completely when throttle is released (i.e., does not continue to roll as if the throttle is activated).
- Clean upholstery and armrests.
- Ensure armrest pad sits flush against arm tube.
- Inspect the seat upholstery for rips and tears.
- Inspect seat swivel for release and engagement (seat locks into the determined swivel positions).
- Inspect for excessive side movement or binding when the drive wheels are raised or turned.
- Inspect front wheel/fork assembly for proper tension by spinning the wheel. The front wheel should come to a gradual stop.
- Check the front fork for damage or corrosion.

- Tighten locknut if the front wheel wobbles noticeably or loosen locknut if the wheel binds to a stop.
- Ensure that wheel bearings are clean and free of moisture.
- Ensure that the bolts and fasteners on the caster assemblies are tight.
- Inspect tires for flat spots and wear.
- Clean molded body shrouds.
- Check that all labels are present and legible.

Inspect/Adjust Weekly

- Ensure that tiller adjustment mechanism engages and disengages properly and securely.
- Ensure that the scooter stops completely when throttle is released (i.e., does not continue to roll as if the throttle is activated).
- Inspect tires for flat spots and wear.

Inspect/Adjust Monthly

- Check brake for binding or interference with travel.
- Inspect front wheel/fork assembly for proper tension by spinning the wheel. The front wheel should come to a gradual stop.
- Tighten locknut if the front wheel wobbles noticeably or loosen locknut if the wheel binds to a stop.
- Inspect seat swivel for release and engagement (seat locks into the determined swivel positions).
- Ensure that the bolts and fasteners on the caster assemblies are tight.

Inspect/Adjust Periodically

- Ensure that the powered scooter drives straight (no excessive drag or pull to one side).
- Check frame for damage and corrosion.
- Ensure that the brake release lever is easy to engage/disengage.
- Inspect for no excessive side movement or binding when the drive wheels are raised or turned.
- Check front fork for damage or corrosion.
- Ensure wheel bearings are clean and free of moisture.
- Clean upholstery and armrests.
- Inspect the seat upholstery for rips and tears.
- Ensure armrest pad sits flush against arm tube.
- Check that all labels are present and legible.
- Inspect electrical components for signs of corrosion. Replace if corroded or damaged.

SECTION 5—MAINTENANCE AND TROUBLESHOOTING

⚠ WARNING

After any adjustments, repair or service and before use, make sure that all attaching hardware is tightened securely - otherwise, injury or damage may occur.

Before performing any maintenance, adjustment or service, turn power Off and remove key from ignition.

DO NOT overtighten hardware attaching to the frame. This could cause damage to the frame.

When storing scooter for prolonged periods of time, remove batteries. Refer to Removing/Installing the Batteries on page 35. After reinstallation, always recharge batteries before use. Refer to Charging the Batteries on page 40.

Use care in storage. **DO NOT** allow any metallic objects to contact the exposed terminals.

Suggested Maintenance Procedures

1. Before using the powered scooter, make sure all nuts and bolts are tight. Check any parts for damage or wear and replace. Check all parts for proper adjustment.
2. Ensure that batteries are properly maintained and charged as required.
3. The wheels and tires should be checked periodically for cracks and wear, and should be replaced by a qualified technician.
4. Regularly check for loose nuts and/or bolts in the front and drive wheels. If loose, have them adjusted by a qualified technician.
5. Clean dirt, dust and grease from exposed components.
6. Periodically have the bearings of the front wheel checked to make sure they are clean and free from moisture.

Troubleshooting

SYMPTOM	PROBABLE CAUSE	SOLUTION
Limited Driving Distance.	Battery not charged long enough. Batteries weak, won't hold charge.	Charge batteries overnight or ensure eight hours of charge between use. Replace batteries. Refer to <u>Removing/Installing the Batteries</u> on page 35.
Batteries not Charging.	Charger not working. Battery connections loose. No current at wall outlet. Bad connection on charger, charger cable, plug or internal wiring problem.	Replace charger. Contact Dealer or a qualified technician. Check all connections. Secure connections. Refer to <u>Removing/Installing the Batteries</u> on page 35. Switch another wall outlet. Replace charger or internal repairs required. Contact Dealer or a qualified technician.
Batteries draw excessive current when charging.	Battery failure.	Replace batteries. Refer to <u>Removing/Installing the Batteries</u> on page 35.
Battery indicator shows the charge level is low too soon after being recharged.	Charger not working. Weak batteries.	Have charger checked. Service or replace the charger. Contact Dealer or a qualified technician. Replace batteries. Refer to <u>Removing/Installing the Batteries</u> on page 35.
Scooter will not drive.	Brake release lever disengaged. Batteries require charging. Key not fully plugged in. Charger plugged in. Fuse blown in battery box. Soft stop engaged. If key is turned off while driving, the scooter holds power for 1.5 seconds slowly decelerating to a stop. Battery connections loose.	Engage brake release lever. Refer to <u>Engaging/Disengaging the Brake Release Lever</u> on page 26. Charge batteries. Refer to <u>Charging the Batteries</u> on page 40. Ensure key is inserted fully into keyswitch. Unplug charger from scooter. Contact Dealer or qualified technician. With key in the off position, wait for 30 seconds and turn key to the on position. Check all connections. Secure connections. Refer to <u>Removing/Installing the Batteries</u> on page 35.

Service Indicator Error Codes

NUMBER OF FLASHES	PROBLEM	SOLUTION
1	Batteries need charging.	Recharge the batteries. Refer to <u>Removing/Installing the Batteries</u> on page 35.
2	Low battery voltage.	Recharge the batteries before using. Refer to <u>Charging the Batteries</u> on page 40.
3	Battery voltage too high.	Check battery condition and connections. Contact a qualified technician to check your battery charger.
4	Motor current error.	Scooter has drawn too much current. Verify there are no objects blocking the tires.
5	Brake release lever is disengaged.	Engage the brake release lever. Refer to <u>Engaging/Disengaging the Brake Release Lever</u> on page 26. Turn the key off, then on to reset. If this does not correct the problem, contact a qualified technician.
6	Throttle control lever not in neutral.	Turn the scooter power off, verify the throttle control lever is in the center position, and turn the power back on. If this does not correct the problem, contact a qualified technician.
7	Throttle control lever malfunction or speed pot error.	Contact a qualified technician.
8	Motor problems.	Contact a qualified technician.
9	Other internal errors.	Contact a qualified technician.

SECTION 6—OPERATION OF THE POWERED SCOOTER

Control Panel

NOTE: For the following information, refer to FIGURE 6.1 on page 24.

1. Speed Control Knob - The speed control knob is located on the right side of the control panel. The Turtle icon represents the slowest speed and the Rabbit icon represents the fastest speed.
2. Battery Charge Display - The battery charge display is located at the top center of the control panel. When the scooter is turned on, the needle on the battery charge display will move to the right to indicate the amount of battery charge. The amount of battery charge is indicated by the colors on the display. If the charge is full, the needle will be to the right, in the GREEN area. As the battery charge decreases, the needle moves, from right to left. When the needle is in the YELLOW area, the batteries are draining and should be charged soon. When the needle is to the far left in the RED area, charge the batteries immediately. If the needle does not move when the scooter is turned on, the batteries should be charged as soon as possible.

⚠ WARNING

When negotiating ramps, if the throttle control lever is released while in forward motion, the powered scooter will roll back approximately one foot before brake engages. If the throttle control lever is released while in reverse motion the powered scooter will roll back approximately three feet before brake engages.

3. Key - The key is just below the control panel. Turn the key:
 - To the Left - Turn the scooter off.
 - To the Right - Turn the scooter on.
4. Horn Button - The horn button is located on left side of the control panel.
5. Throttle Control Lever - The throttle control lever is located in front of the handles on the tiller assembly.
6. Service Indicator - The service indicator will flash if there is a problem with the scooter. The number of flashes indicates the type of error. Refer to Service Indicator Error Codes on page 22.

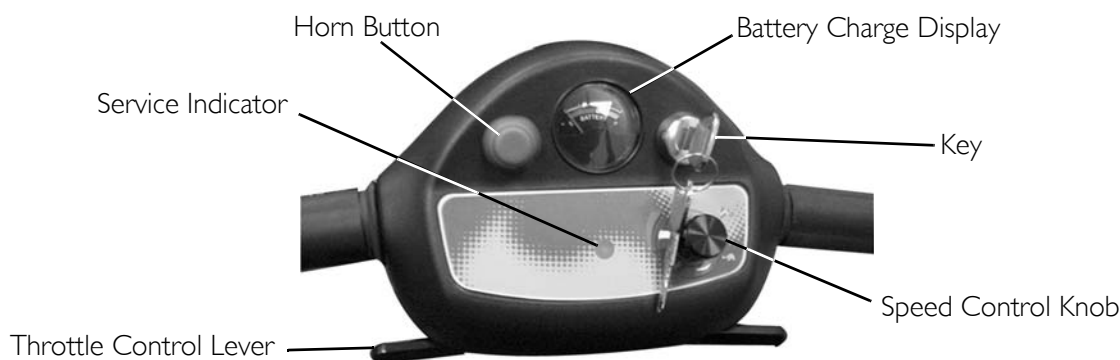

FIGURE 6.1 Control Panel

Operating the Scooter

⚠ WARNING

After any adjustments, repair or service and before use, make sure that all attaching hardware is tightened securely - otherwise injury or damage may result.

DO NOT make sharp turns in the forward or reverse direction at excessive speed. Failure to observe the warning can cause the scooter to tip over and may result in injury to user and/ or damage to the product.

To determine and establish your particular safety limits, practice bending, reaching and transferring activities in several combinations in the presence of a qualified healthcare professional before attempting active use of the powered scooter.

Ensure seat is properly locked before attempting transfer into or out of the powered scooter. Attempting unsafe transfers may cause a fall from the powered scooter resulting in bodily injury.

For individuals with balance problems, practice transferring activities with an assistant in the presence of a qualified healthcare professional. DO NOT attempt to transfer into or out of the powered scooter without assistance.

1. Before operating the powered scooter, review [Control Panel](#) on page 23.
2. Install the batteries. Refer to [Removing/Installing the Batteries](#) on page 35.
3. Charge the batteries. Refer to [Charging the Batteries](#) on page 40.
4. Transferring to and from the seat can be accomplished in one of two ways:
 - Flipping up the armrest makes entering/exiting easier.
 - Rotating seat to the direction of transfer. Refer to [Adjusting 90° Seat Swivel](#) on page 29.
5. Once you have transferred into the seat, rotate seat to the forward position and flip arms down.
6. Adjust the tiller to a comfortable angle. Refer to [Adjusting the Tiller Angle](#) on page 31.
7. Adjust speed control knob to the appropriate setting.

NOTE: For driving indoors or on uneven terrain, a slower speed is recommended. For soft terrain or steep inclines (no greater than 8°), a faster speed may be necessary.

8. Insert the key into the ignition and turn it to the on position.

⚠ WARNING

ALWAYS depress the throttle control lever gradually. This will ensure smooth safe starts.

NOTE: Throttle control levers operate such that moving one will also move the opposite side throttle control lever.

9. To operate the scooter, depress the throttle control lever in the following manner:

- To Move Forward - Push the right side throttle control lever (away from the user) or pull the left side throttle control lever towards the user).
- To Move in Reverse - Push the left side throttle control lever (away from the user) or pull the right side throttle control lever (towards the user).
- To Stop - Release the throttle control lever and the powered scooter will quickly slow down and the brake will engage.

NOTE: To equip the scooter for left hand operation, contact a qualified technician.

The powered scooter is equipped with a "proportional" control meaning that the farther you depress the throttle control lever, the faster the powered scooter travels. With a proportional control, you can drive as slowly in the high speed setting as you can in the low speed setting. Your top speed, however, is limited by the setting of the speed-control knob. For safety reasons, reverse speed is limited to approximately 50% of forward speed.

When first learning to drive, adjust speed control knob for a slow speed and try to drive the powered scooter as slowly as possible by depressing the throttle control lever only slightly. This exercise will help you learn to utilize the full potential of the proportional control and allow you to start and stop smoothly.

Engaging/Disengaging the Brake Release Lever

⚠ WARNING

Ensure that the brake-release lever is in the engaged position before driving. There should be an audible "click" when stopping and starting the scooter.

NOTE: For the following procedure, refer to FIGURE 6.2.

The brake release lever manually engages and disengages the brake. The brake release lever is located under the seat on the right side.

The brake must be engaged in normal driving conditions. Activation of the throttle control lever automatically releases the brake so that the powered scooter can drive. Releasing the throttle control lever automatically engages the brake to prevent the powered scooter from rolling on its own.

When the brake release lever is disengaged and the key is removed, the powered scooter can be pushed. The powered scooter cannot be driven with the brake in the disengaged position.

1. To Engage the Brake Release Lever (Drive) - Push the brake release lever down.
2. To Disengage the Brake Release Lever (Push) - Pull the brake release lever up.

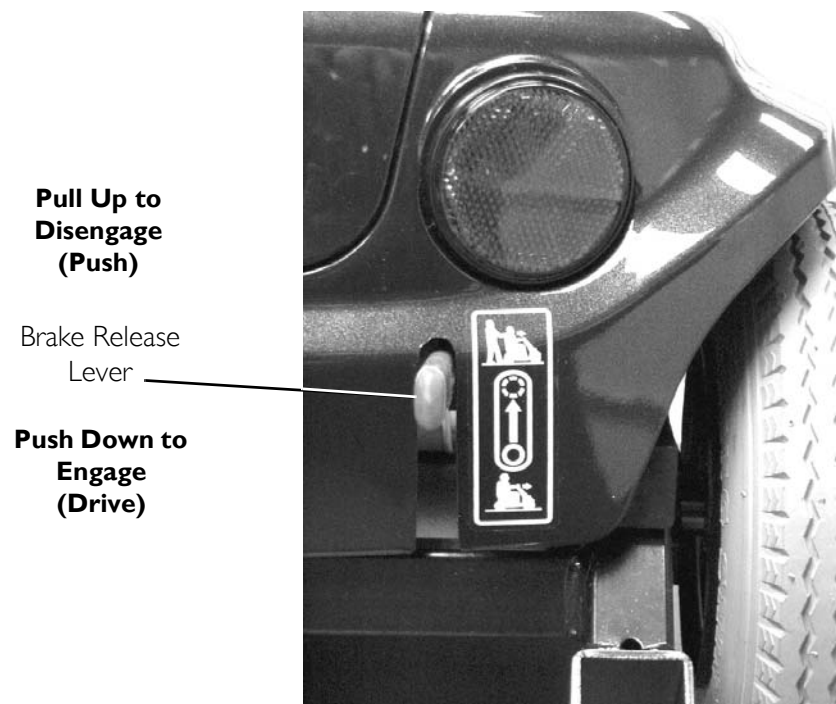

FIGURE 6.2 Engaging/Disengaging the Brake Release Lever

SECTION 7—SEAT AND ARMS

⚠ WARNING

After any adjustments, repair or service and before use, make sure that all attaching hardware is tightened securely - otherwise injury or damage may result.

Before performing any maintenance, adjustment or service, turn power off and remove key from ignition.

NOTE: Refer to *Label Locations* on page 7 for pinch point location.

Removing/Installing the Seat

⚠ WARNING

Before use, ensure that the seat is in the locked position. The seat lever **MUST** be pulled up to the 90° position to allow the seat to drop into the locked position. Otherwise, a fall from the scooter could occur causing bodily injury and/or damage to the scooter.

NOTE: For this procedure, refer to FIGURE 7.1.

NOTE: Seat lock lever located on left side of seat.

Removing

1. Fold down seat back.
2. Pull up the seat lock lever.
3. Lift the seat assembly up and away from the seat post.

Installing

1. Lower the seat assembly onto the seat post.
2. Pull the seat lock lever up to allow the seat to drop into the locked position.
3. Lift up on seat assembly to ensure the seat is secure.



FIGURE 7.1 Removing/Installing the Seat

Adjusting Seat Height

NOTE: For this procedure, refer to FIGURE 7.2.

1. Remove the seat. Refer to Removing/Installing the Seat on page 27.
2. Remove the mounting bolt, two curved washers and lock nut securing the seat post to the frame tube.
3. Align the frame tube mounting hole with one of three seat post mounting holes to achieve desired seat height.
4. Using the mounting bolt, two curved washers and locknut, secure the seat post to the frame tube.
5. Install the seat. Refer to Removing/Installing the Seat on page 27.

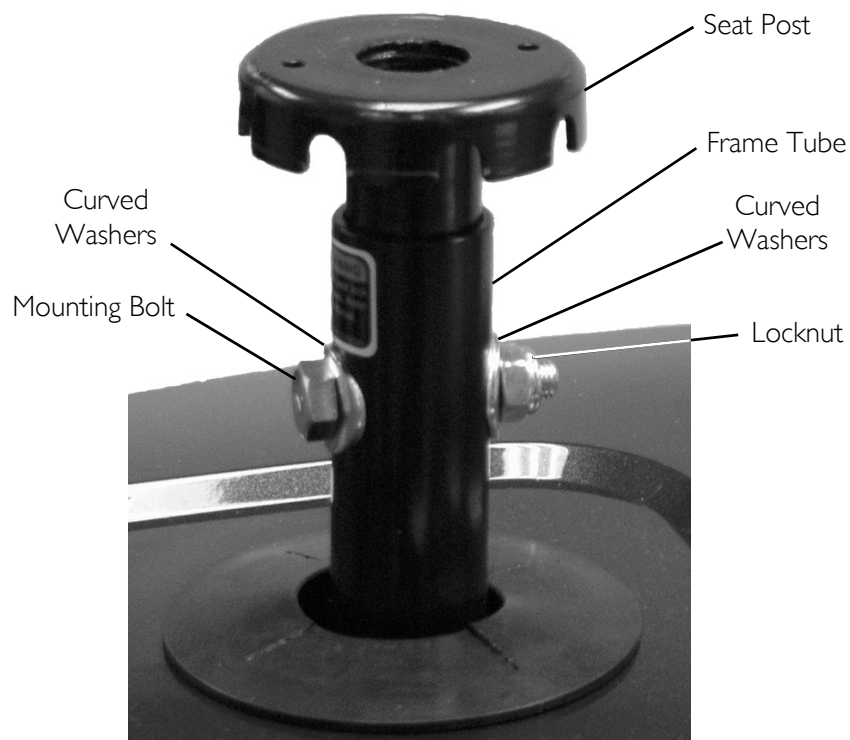

FIGURE 7.2 Adjusting Seat Height

Adjusting 90° Seat Swivel

⚠ WARNING

Ensure that seat is locked into the forward position before and during operation of the scooter. Otherwise, injury to the user and/or damage to the scooter may result.

CAUTION

Use the seat swivel option with caution when accessories are installed (such as safety flag, crutch/cane holder, etc.). Otherwise, damage to the scooter or property may occur.

NOTE: For this procedure, refer to FIGURE 7.3.

1. Pull up the seat lock lever to unlock the seat.
2. Rotate the seat to the desired position.
3. Release the seat lock lever to lock the seat in the desired position.

NOTE: Ensure that the seat is locked in the forward facing position before operating the scooter.

Adjusting the Seat Slide

NOTE: For this procedure, refer to FIGURE 7.3

1. Lift the seat slide lever located on the right side of the seat.
2. Slide the seat forward or back to the desired position.
3. Release the seat slide lever and allow the seat to lock into position.



FIGURE 7.3 Adjusting 90° Seat Swivel

Adjusting the Arm Width

NOTE: For this procedure, refer to FIGURE 7.4.

NOTE: When installing the arms during set up, the four mounting screws are installed on the seat hinge for shipping purposes.

1. Loosen the knob securing the arm tube to the seat frame.
2. Push the arm in or out to the desired position.

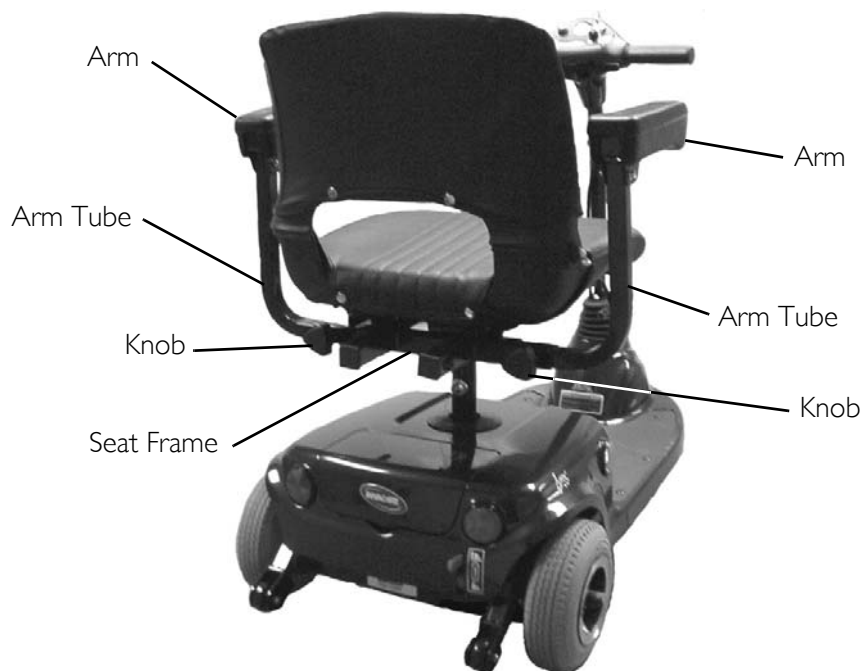

FIGURE 7.4 Adjusting the Arm Width

Replacing Armrest Pads

NOTE: For this procedure, refer to FIGURE 7.5.

1. Remove the one mounting screw that secure the armrest pad to arm.
2. Remove the old armrest pad.
3. Install new armrest pad and securely tighten with existing mounting screw.
4. If necessary, repeat STEPS 1-3 to replace the other armrest pad.

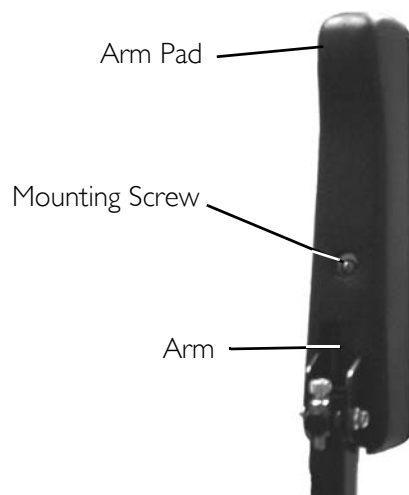

FIGURE 7.5 Replacing Armrest Pads

SECTION 8—TILLER ADJUSTMENT

Adjusting the Tiller Angle

⚠ WARNING

Before performing any maintenance, adjustment or service, turn power **Off** and remove key from ignition.

Ensure that tiller is properly adjusted before driving the scooter.

After making any tiller angle adjustments and before use, the tiller **MUST** be securely locked into position. Otherwise, a fall from the scooter could occur causing bodily injury and/or damage to the scooter. Gently, push/pull against tiller to ensure that the tiller is securely engaged into the adjustment plate.

NOTE: For this procedure, refer to FIGURE 8.1.

NOTE: The powered scooters feature an adjustable tiller. The tiller locks into one of three positions.

NOTE: The tiller can also be folded down and locked into this position for transportation and storage.

1. Pull out the tiller adjustment lever until the pin disengages from the mounting hole.
2. Move the tiller to the desired position.
3. Release the tiller adjustment lever to lock the pin into the desired mounting hole.
4. Gently push/pull against tiller to ensure that the tiller is securely locked.

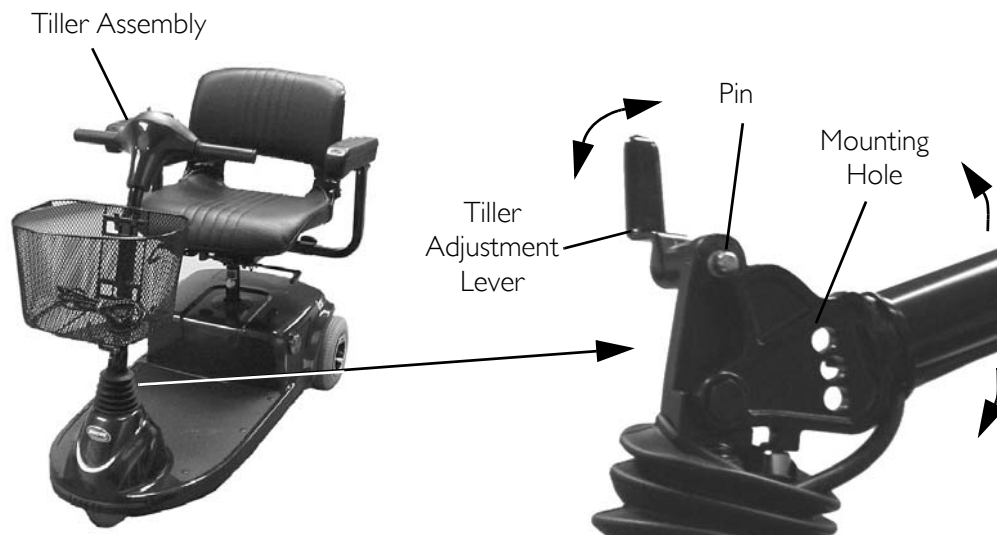

FIGURE 8.1 Adjusting the Tiller Angle

SECTION 9—WHEELS AND CASTERS

⚠ WARNING

After any adjustments, repair or service and before use, make sure that all attaching hardware is tightened securely - otherwise injury or damage may result.

Before performing any maintenance, adjustment or service, turn power Off and remove key from ignition.

Removing/Installing the Drive Wheels

NOTE: For this procedure, refer to FIGURE 9.1 on page 33.

Removing

1. Turn power off and remove the key from the ignition.
2. Remove the seat. Refer to Removing/Installing the Seat on page 27.
3. Place the rear frame assembly (not shown) up on blocks so that the drive wheels are off the ground.
4. Remove the cap, nut, large washer and small washer that secure the drive wheel to the drive shaft.
5. Remove the existing drive wheel assembly from the drive shaft.

NOTE: Use a wheel puller if necessary to remove the wheel from the drive shaft.

6. Remove keystock from drive shaft. Set aside.
7. If necessary, repeat STEPS 1-6 to remove other drive wheel.

Installing

1. Place keystock in cutout on drive shaft as shown in FIGURE 9.1.

NOTE: The keystock in the drive shaft MUST lineup with the cutout in the wheel hub.

NOTE: If necessary, use a rubber hammer to gently tap drive wheel completely into position on the drive shaft.

2. Install the drive wheel onto the drive shaft.
3. Secure wheel to drive shaft using the large washer, small washer and nut. Securely tighten.
4. Install the cap onto the nut.
5. Repeat STEPS 1-4 to install the other drive wheel.
6. Install the seat. Refer to Removing/Installing the Seat on page 27.

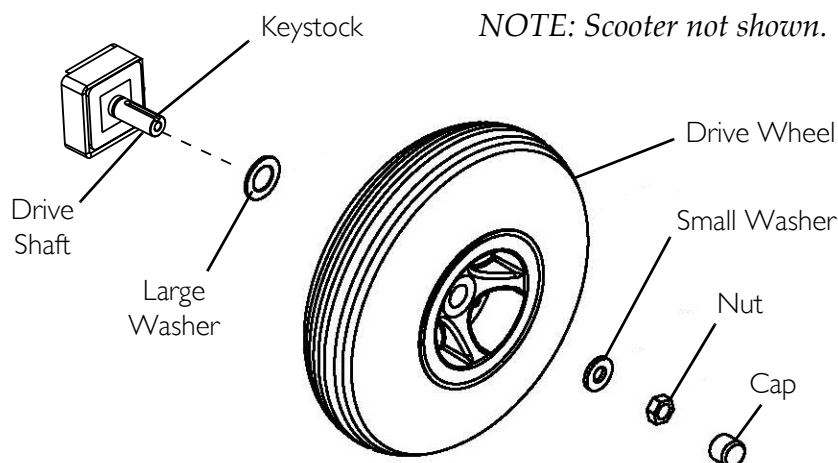

FIGURE 9.1 Removing/Installing the Drive Wheels

Removing/Installing the Front Wheel

NOTE: For this procedure, refer to FIGURE 9.2.

NOTE: Take note of position and orientation of wheel and mounting hardware before removing.

Removing

1. Turn power off and remove the key from the ignition.
2. Place the front of the powered scooter up on blocks so that the front wheel is off the ground.
3. Remove the mounting screw, locknut, two spacers and washer that secure the front wheel to the fork.
4. Remove the front wheel from the fork.

Installing

1. Align the front wheel with the fork mounting holes.
2. Using the mounting screw, locknut, two spacers and washer, secure the front wheel to the fork.
3. Securely tighten the front wheel mounting hardware.

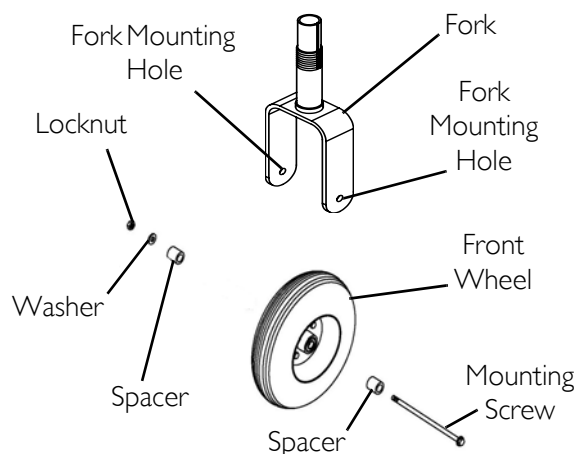

FIGURE 9.2 Removing/Installing the Front Wheel

SECTION 10—BATTERIES

⚠ WARNING

Before performing any maintenance adjustment or service, turn power off and remove key from ignition.

NEVER allow any of your tools and/or battery cables to contact both battery terminals at the same time. An electrical short may occur and serious personal injury or damage may occur.

The use of rubber gloves is recommended when working with batteries.

DO NOT tip the batteries. Keep the batteries in an upright position.

Invacare strongly recommends that battery installation and battery replacement always be done by a qualified technician.

All battery terminals caps (two on the left battery and two on the right battery) **MUST** be installed prior to use.

CAUTION

When connecting the battery cables to the batteries, the battery cables **MUST** be connected to the battery terminals/posts as shown in **FIGURE 10.3** - otherwise damage to the battery may result.

NOTE: If there is battery acid in the bottom of the battery box or on the sides of the batteries, apply baking soda to these areas to neutralize the battery acid. Before reinstalling the existing or new batteries, clean the baking soda from the battery tray or batteries being sure to avoid contact with skin and eyes. Determine source of contamination. Never install/reinstall a battery with a cracked or otherwise damaged case.

Recommended Battery Type

⚠ WARNING

The warranty and performance specifications contained in this manual are based on the use of deep cycle gel cell batteries. Invacare strongly recommends their use as the power source for this unit.

CAUTION

Failure to use the correct battery size and/or voltage may cause damage to the powered scooter and give unsatisfactory performance.

NOTE: For this procedure, refer to FIGURE 10.1 on page 35.

The Lynx L-3X powered scooters are designed to use two 12 volt, 36-Amp-hour (36 AH) batteries.

NOTE: Recommended battery type is spill proof and requires no maintenance except routine charging.

NOTE: Charge batteries daily. DO NOT allow batteries to completely discharge.

NOTE: Invoacare recommends that both batteries be replaced if one battery is defective.

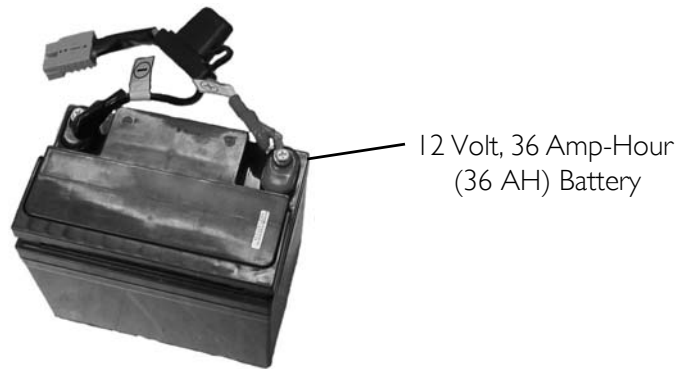

FIGURE 10.1 Recommended Battery Type

Removing/Installing the Batteries

NOTE: For this procedure, refer to FIGURE 10.2 on page 36.

Removing

1. Place the powered scooter in a well ventilated area.

CAUTION

Work should be performed in an area without risking damage to carpeting or floor covering.

2. Turn power off and remove the key from the ignition.
3. Remove the seat. Refer to [Removing/Installing the Seat](#) on page 27.
4. Lifting up to release the hook and loop strips, remove the rear shroud from the scooter.
5. Disconnect the two GRAY battery connectors from the wiring harness connectors.
6. Perform the following to remove a battery from the battery tray:
 - A. Pull the hook and loop fastening battery strap apart.
 - B. Lift the battery from the battery tray.
7. Repeat STEP 6 to remove the remaining battery.
8. If necessary, remove the battery cables. Refer to [Connecting/Disconnecting the Battery Cables](#) on page 37.

Installing

1. Place the powered scooter in a well ventilated area where work can be performed without risking damage to carpeting or floor covering.
2. Turn power off and remove the key from the ignition.

3. If necessary, connect the battery cable. Refer to Connecting/Disconnecting the Battery Cables on page 37.
4. Remove the seat. Refer to Removing/Installing the Seat on page 27.
5. Lifting up to release the hook and loop strips, remove the rear shroud from the scooter.
6. Perform the following to install a battery from the battery tray:
 - A. With the battery terminals facing towards the center of the scooter, position the battery onto the battery tray.
 - B. Position the hook and loop fastening battery strap around the battery and to secure the battery to the battery tray.
7. Repeat STEP 6 to install the remaining battery into the battery tray.
8. Connect the two GRAY battery connectors to the wiring harness connectors.
9. Align tabs on the rear shroud with the slots (not shown in figure) in the front shroud.
10. Place rear shroud on the frame and press down slightly.
11. Reinstall the seat. Refer to Removing/Installing the Seat on page 27.

NOTE: New batteries MUST be fully charged before using, otherwise the life of the batteries will be reduced.

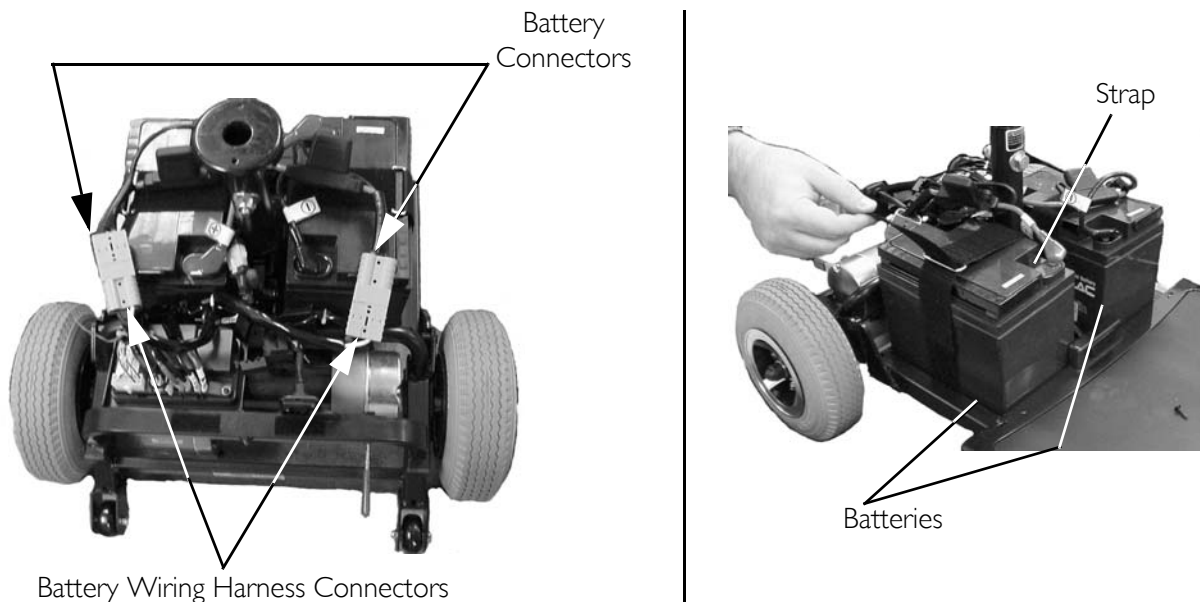
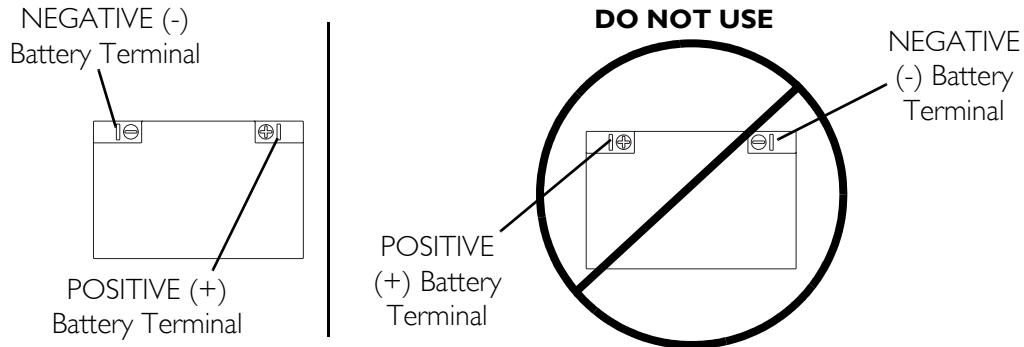

FIGURE 10.2 Removing/Installing the Batteries

Connecting/Disconnecting the Battery Cables

⚠ WARNING

Battery terminal configuration shown below **MUST** be used. Batteries that have the reversed terminal configuration **MUST NOT** be used - otherwise serious injury or damage may occur.



NEVER allow any of your tools and/or battery cable(s) to contact **BOTH** battery terminal(s)/post(s) at the same time. An electrical short may occur and serious personal injury or damage may occur.

The use of rubber gloves and chemical goggles and face shield is recommended when working with batteries.

Do not remove fuse or mounting hardware from the **POSITIVE (+) RED** battery cable/mounting screw.

NEVER defeat or bypass any fuse. **ONLY** replace with a fuse of the same rating.

NOTE: For this procedure, refer to FIGURE 10.3 on page 39.

Connecting

1. Install battery terminal cap(s) onto battery cable(s) as follows:
 - A. RED battery terminal cap onto RED battery cable.
 - B. GREY battery terminal cap onto BLACK battery cable.

⚠ WARNING

When connecting the battery cables to the batteries, the battery cables **MUST be connected to the battery terminals/posts as shown in **FIGURE 10.3**, otherwise damage to the battery cable may result when installing battery terminal caps.**

2. Connect battery cables to battery terminals:
 - A. NEGATIVE (-) BLACK battery cable to NEGATIVE (-) battery terminal/post.
 - B. POSITIVE (+) RED battery cable to POSITIVE (+) battery terminal/post.
3. Secure the battery cables ring terminal to the battery terminals, BLACK to NEGATIVE (-) and red to POSITIVE (+), with the provided mounting bolt and locknut. Securely tighten.
4. Verify all battery cables ring terminal are correctly installed and securely tightened.
5. Slide terminal caps down battery cables and onto battery clamps.
6. Position the batteries on the scooter. Refer to Removing/Installing the Batteries on page 35.

NOTE: New Battery(ies) MUST be fully charged before using, otherwise the life of the battery(ies) will be reduced.

7. If necessary, charge the battery(ies). Refer to Charging the Batteries on page 40.
8. Install the rear shroud. Refer to Removing/Installing the Rear Shroud on page 44.
9. Install the seat. Refer to Removing/Installing the Seat on page 34.

Disconnecting

⚠ WARNING

The use of rubber gloves and chemical goggles and face shield is recommended when working with batteries.

NEVER allow any of your tools and/or battery cable(s) to contact both battery terminal(s)/post(s) at the same time. An electrical short may occur and serious personal injury or damage may occur.

1. Remove the batteries. Refer to Removing/Installing the Batteries on page 35.
2. Slide terminal caps up on the battery cables.
3. Disconnect the battery cables from the battery terminals by remove the mounting bolts and locknuts securing the battery cables from battery terminals:
 - A. POSITIVE (+) RED battery cable from the POSITIVE (+) battery terminal.
 - B. NEGATIVE (-) BLACK battery cable from NEGATIVE (-) battery terminal.

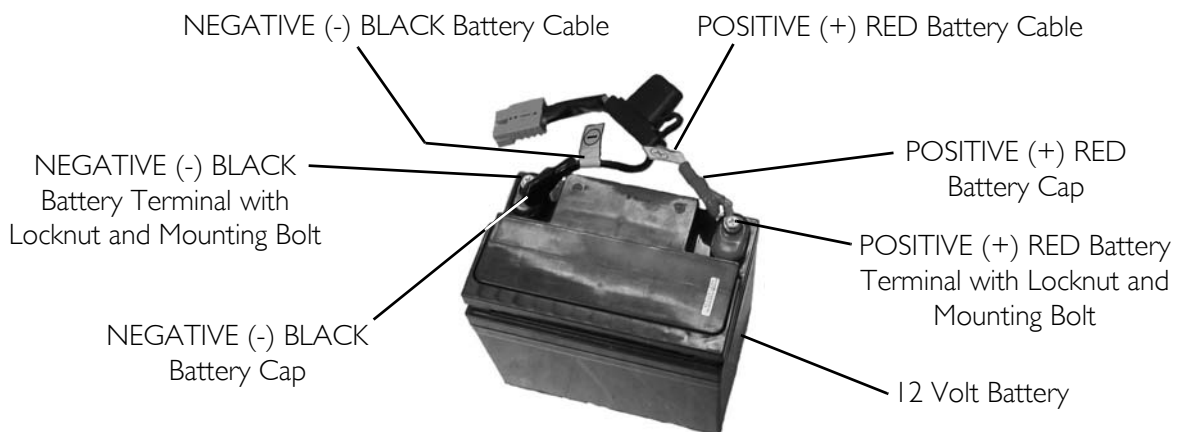

FIGURE 10.3 Connecting/Disconnecting the Battery Cables

Charging the Batteries

⚠ WARNING

NEVER attempt to recharge the batteries by attaching cables directly to the battery terminals or clamps.

DO NOT attempt to recharge the batteries and operate the powered scooter at the same time.

Only use the provided charger with this product.

CAUTION

New batteries MUST be fully charged prior to initial use of the powered scooter.

DO NOT sit in the scooter while recharging the batteries.

ALWAYS charge new batteries before initial use or battery life will be reduced.

As a general rule, you should recharge your batteries as frequently as possible to assure the longest possible life and to minimize required charging time. Plan to recharge them when you do not anticipate using the powered scooter.

The range per battery charge using recommended batteries should be approximately five to nine hours of typical operation. Extensive use on inclines may substantially reduce per charge mileage.

NOTE: For this procedure, refer to FIGURE 10.4 on page 41.

NOTE: The powered scooter is designed with an electrical lockout to prevent it from being driven while the charger is plugged into an outlet.

NOTE: Always charge the batteries completely until the battery charger light turns GREEN.

1. Turn the key to the Off position.
2. Ensure the brake release lever is engaged. Refer to Engaging/Disengaging the Brake Release Lever on page 26.
3. Lifting up on trunk lid, release the hook and loop strips and remove the trunk lid from the scooter.
4. Open the charger port cover.
5. Plug one end of the charger cable into the battery charger port located on the scooter.
6. Plug the other end of the charger cable into 110-volt wall outlet.

NOTE: The battery charger light will be YELLOW or RED.

7. Allow the batteries to charge until the charger light turns GREEN.

8. Perform one of the following:
 - Battery charger light turns GREEN - Unplug the charger cable from the scooter and the wall outlet.
 - Battery charger light flashes GREEN for over 40 minutes - Perform the following steps:
 - i. Check that the charger cable is correctly connected to the scooter and the wall outlet.
 - ii. Check that the scooter is turned off.
 - iii. If steps i and ii do not correct the problem, contact a qualified technician.
9. Unplug the charger cable from the wall outlet.
10. Unplug the charger cable from the scooter.
11. Close the charger port cover.
12. Position the trunk lid onto the scooter and press to secure the hook and loop strips.

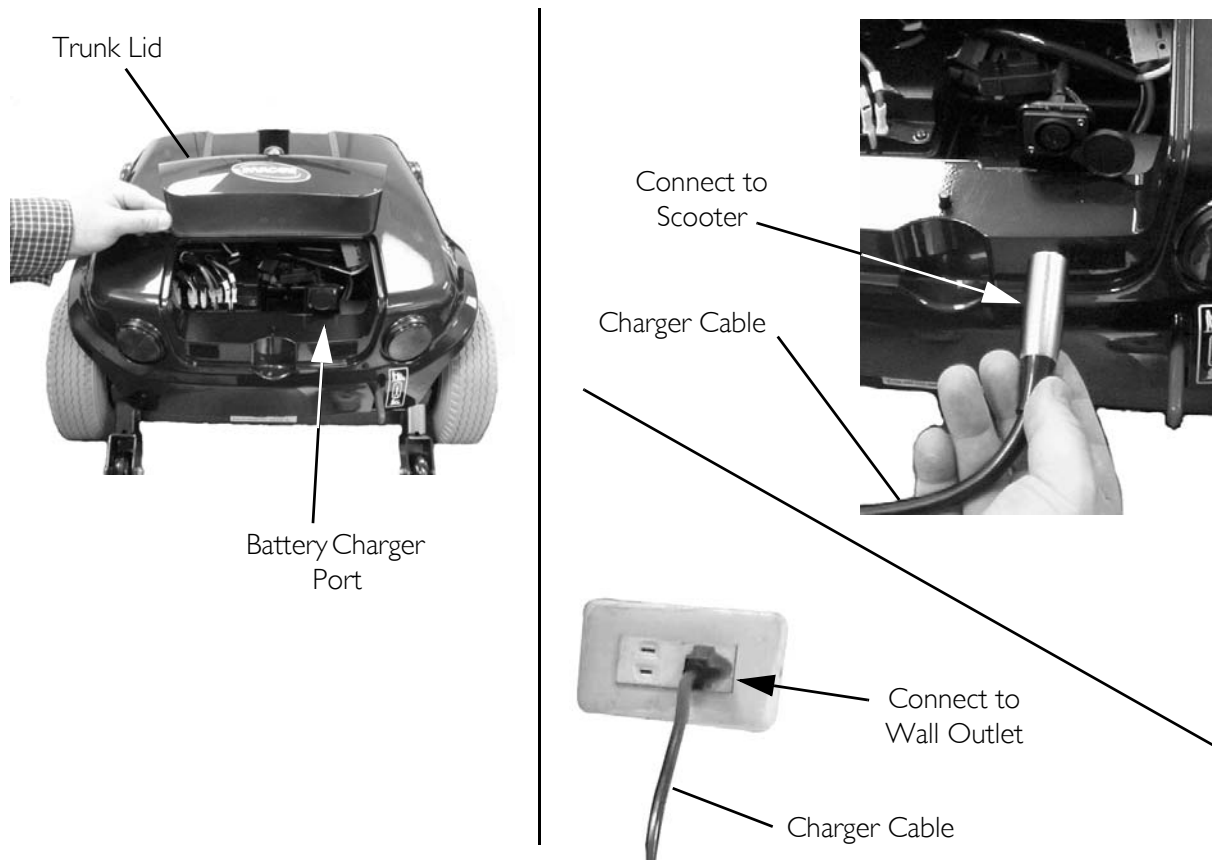

FIGURE 10.4 Charging the Batteries

SECTION 11—TRANSPORTING

⚠ WARNING

After any adjustments, repair or service and before use, make sure that all attaching hardware is tightened securely - otherwise injury or damage may result.

Before performing any maintenance, adjustment or service, turn power off and remove key from ignition.

DO NOT lift the scooter by the rear shroud - otherwise damage to the scooter may occur.

Transporting the Scooter

NOTE: For this procedure, refer to FIGURE 11.1 on page 43.

Disassembling

1. Turn power off and remove the key from the ignition.
2. Remove any installed accessories.
3. Remove the seat. Refer to Removing/Installing the Seat on page 27.
4. Remove the batteries. Refer to Removing/Installing the Batteries on page 35.
5. Disconnect the tiller wiring connector from the controller wiring connector (Detail "A").
6. Hold the seat post with one hand.
7. With the other hand, push the release lever to the rear of the scooter (Detail "A").
8. Lift the seat post to separate the front frame assembly from the rear frame assembly pins.
9. Fold tiller down to lowest locked position. Refer to Adjusting the Tiller Angle on page 31.

Assembling

1. Unfold tiller. Refer to Adjusting the Tiller Angle on page 31.
2. Position the rear frame between the curved locking brackets of the front frame assembly.
3. Hold the seat post and align the curved locking brackets on the front frame assembly with the rear frame assembly pins.
4. While holding the seat post, slowly lower the front frame assembly onto the rear frame assembly pins until the release lever locks.
5. Connect the tiller wiring connector to the controller wiring connector.

6. Install the batteries. Refer to Removing/Installing the Batteries on page 35.
7. Install the seat. Refer to Removing/Installing the Seat on page 27.
8. If necessary, install any accessories to be used.

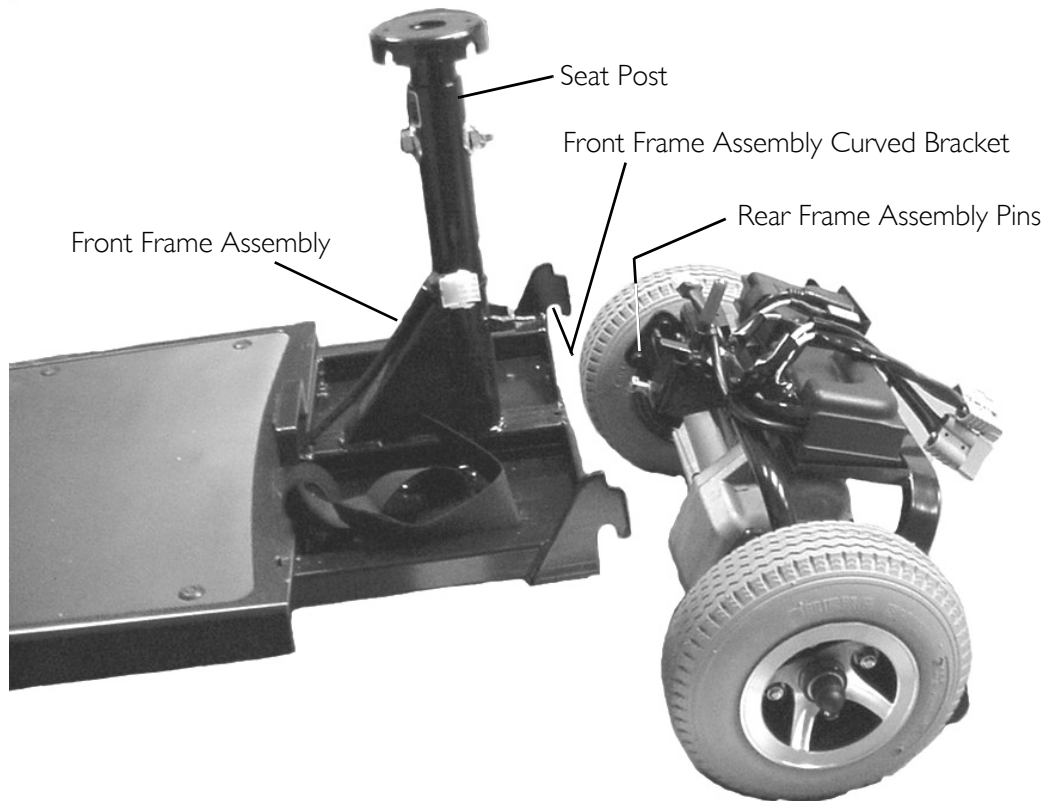
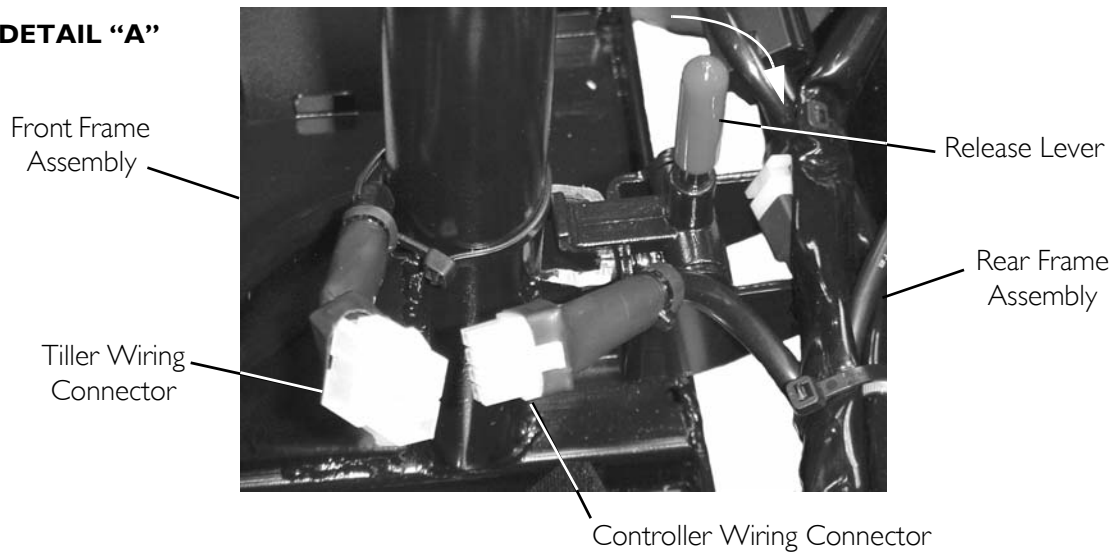
DETAIL "A"**FIGURE 11.1** Transporting the Scooter

SECTION 12—ACCESSORIES

⚠ WARNING

After **ANY** adjustments, repair or service and before use, make sure that all attaching hardware is tightened securely - otherwise injury or damage may result. Before performing any maintenance, adjustment or service, turn power off and remove key from ignition.

NOTE: The crutch/cane holder, safety flag, rear mounted basket and oxygen holder all install into one of two accessory tubes. More than one accessory may be installed at one time depending on accessories installed.

Installing/Removing the Crutch/Cane Holder

⚠ WARNING

The installation of the crutch/cane holder onto the back of the scooter seat significantly increases the length of the scooter. When turning the scooter or swiveling the scooter seat, it is important to take note of this increased length - otherwise, injury and/or damage to the surrounding property may result.

NOTE: For this procedure, refer to FIGURE 12.1.

Installing

1. Install the crutch/cane holder into the accessory tube located on the back of the seat.
2. Install the mounting knob to secure the crutch/cane holder in place. Securely tighten.
3. Align the slot on the base with the hook on the crutch/cane holder and slide base down into position.

Removing

1. Remove the crutch/cane holder from the accessory tube.
2. Remove the mounting knob that secures the crutch/cane holder in place.
3. Remove the crutch/cane holder from the accessory tube.

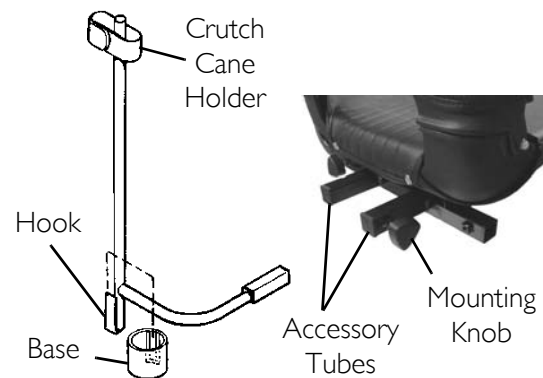

FIGURE 12.1 Installing/Removing the Crutch/Cane Holder

Installing/Removing the Safety Flag

⚠ WARNING

The installation of the safety flag onto the back of the scooter seat significantly increases the length of the scooter. When turning the scooter or swiveling the scooter seat, it is important to take note of this increased length - otherwise, injury and/or damage to the surrounding property may result.

NOTE: For this procedure, refer to FIGURE 12.2.

Installing

1. Install the bracket into the accessory tube located on the back of the seat.
2. Install mounting knob to secure the bracket in place. Securely tighten.
3. Install safety flag into bracket.

Removing

1. Remove the safety flag from the bracket.
2. Remove the mounting knob that secures the bracket in place.
3. Remove the bracket from the accessory tube located on the back of the seat.

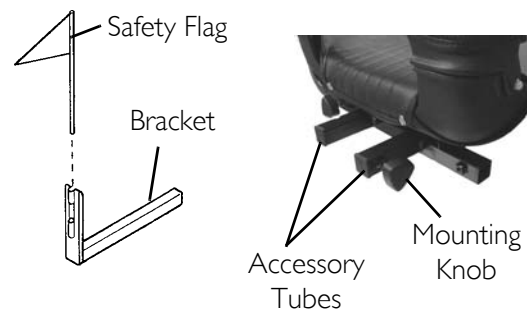

FIGURE 12.2 Installing/Removing the Safety Flag

Installing/Removing/Using the Walker Holder

⚠ INSTALLATION WARNINGS

After ANY adjustments, repair or service and before use, make sure that all attaching hardware is tightened securely.

The installation of the walker holder onto the back of the scooter seat significantly increases the length of the scooter. When turning the scooter or swiveling the scooter seat, it is important to take note of this increased length - otherwise, injury and/or damage to the surrounding property may result.

Installing/Removing the Walker Holder

NOTE: For this procedure, refer to FIGURE 12.3.

NOTE: Reverse this procedure to remove the walker holder.

1. If necessary, loosen but **DO NOT** remove the mounting knob.
2. Install the walker holder into the accessory tube.
3. Thread the mounting knob into the welded nut on the accessory tube. Securely tighten.

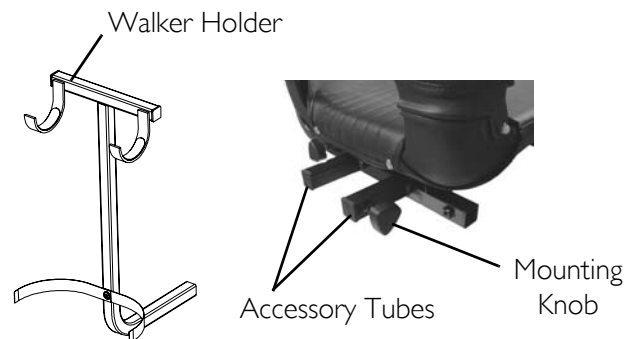

FIGURE 12.3 Installing/Removing the Walker Holder

Using the Walker Holder

NOTE: For this procedure, refer to FIGURE 12.4.

1. Fold walker. Refer to walker instructions.

NOTE: Walker MUST be folded before using walker holder.

2. Hang folded walker on walker holder hooks.
3. Secure walker with hook and loop straps.

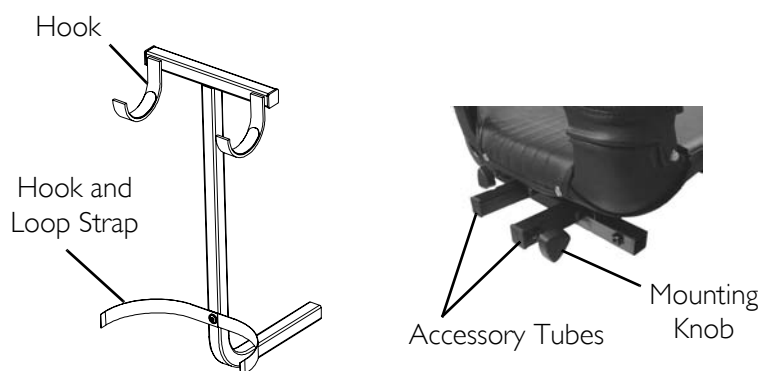

FIGURE 12.4 Using the Walker Holder

Installing/Removing the Rear Mounted Basket

⚠ WARNING

The rear mounted basket is rated for a maximum capacity of ten lbs.

After **ANY** adjustments, repair or service and before use, make sure that all attaching hardware is tightened securely.

The installation of the basket and basket bracket onto the back of the scooter seat increases the length of the scooter. When turning the scooter or swiveling the scooter seat, it is important to take note of this increased length - otherwise, injury and/or damage to surrounding property may occur.

NOTE: For this procedure, refer to FIGURE 12.5.

Installing

1. Loosen but **DO NOT** remove the mounting knob.
2. Install the basket bracket into the accessory tube.
3. Thread the mounting knob into the welded nut on the accessory tube. Securely tighten.
4. Align the mounting clips on the bracket with the slots on the basket and slide the basket down securely into position.

Removing

1. Remove the basket from the bracket.
2. Loosen the mounting knob.
3. Remove the basket bracket from the accessory tube.
4. Tighten the mounting knob.

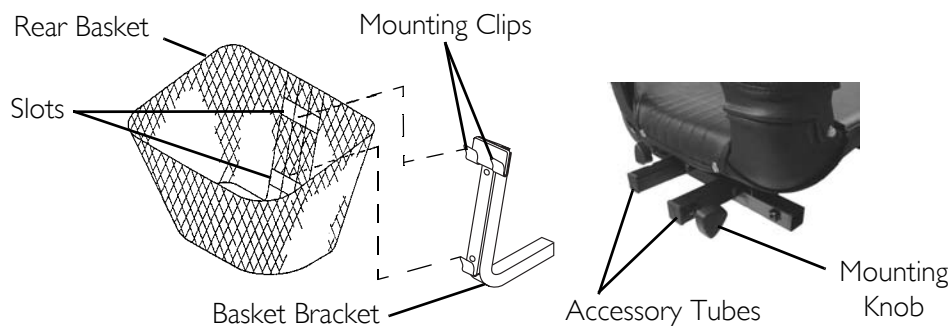

FIGURE 12.5 Installing/Removing the Rear Mounted Basket

LIMITED WARRANTY

PLEASE NOTE: THE WARRANTY BELOW HAS BEEN DRAFTED TO COMPLY WITH FEDERAL LAW APPLICABLE TO PRODUCTS MANUFACTURED AFTER JULY 4, 1975.

This warranty is extended only to the original purchaser/user of our products.

This warranty gives you specific legal rights and you may also have other legal rights which vary from state to state.

Invacare warrants all electronics and electrical components (excluding batteries), transaxle and frame to be free from defects in materials and workmanship for a period of twelve (12) months from the date of purchase from Invacare or a dealer. Invacare warrants all batteries for a period of six (6) months from the date of purchase from Invacare or a dealer. If within such warranty period any such product shall be proven to be defective, such product shall be repaired or replaced at Invacare's option. This warranty does not include any labor or shipping charges incurred in replacement part installation or repair of any such product. Invacare's sole obligation and your exclusive remedy under this warranty shall be limited to such repair and/or replacement.

For warranty service, please contact the dealer from whom you purchased your Invacare product. In the event you do not receive satisfactory warranty service, please write directly to Invacare at the address on the bottom of the back cover. Provide dealer's name address, date of purchase, indicate nature of the defect and, if the product is serialized, indicate the serial number. Do not return products to our factory without our prior consent.

LIMITATIONS AND EXCLUSIONS: THE FOREGOING WARRANTY SHALL NOT APPLY TO SERIAL NUMBERED PRODUCTS IF THE SERIAL NUMBER HAS BEEN REMOVED OR DEFACED, PRODUCTS SUBJECT TO NEGLIGENCE, ACCIDENT, IMPROPER OPERATION, MAINTENANCE OR STORAGE, COMMERCIAL OR INSTITUTIONAL USE, PRODUCTS MODIFIED WITHOUT INVACARE'S EXPRESS WRITTEN CONSENT INCLUDING, BUT NOT LIMITED TO, MODIFICATION THROUGH THE USE OF UNAUTHORIZED PARTS OR ATTACHMENTS; PRODUCTS DAMAGED BY REASON OF REPAIRS MADE TO ANY COMPONENT WITHOUT THE SPECIFIC CONSENT OF INVACARE, OR TO A PRODUCT DAMAGED BY CIRCUMSTANCES BEYOND INVACARE'S CONTROL, AND SUCH EVALUATION WILL BE SOLELY DETERMINED BY INVACARE. THE WARRANTY SHALL NOT APPLY TO PROBLEMS ARISING FROM NORMAL WEAR OR FAILURE TO ADHERE TO THESE INSTRUCTIONS. A CHANGE IN OPERATING NOISE, PARTICULARLY RELATIVE TO MOTORS AND GEARBOXES DOES NOT CONSTITUTE A FAILURE. ALL SUCH DEVICES WILL EXHIBIT A CHANGE IN OPERATING NOISE DUE TO AGING.

THE FOREGOING EXPRESS WARRANTY IS EXCLUSIVE AND IN LIEU OF ANY OTHER WARRANTIES WHATSOEVER, WHETHER EXPRESS OR IMPLIED, INCLUDING THE IMPLIED WARRANTIES OF MERCHANTABILITY AND FITNESS FOR A PARTICULAR PURPOSE, AND THE SOLE REMEDY FOR VIOLATIONS OF ANY WARRANTY WHATSOEVER, SHALL BE LIMITED TO REPAIR OR REPLACEMENT OF THE DEFECTIVE PRODUCT PURSUANT TO THE TERMS CONTAINED HEREIN, THE APPLICATION OF ANY IMPLIED WARRANTY WHATSOEVER SHALL NOT EXTEND BEYOND THE DURATION OF THE EXPRESS WARRANTY PROVIDED HEREIN. INVACARE SHALL NOT BE LIABLE FOR ANY CONSEQUENTIAL OR INCIDENTAL DAMAGES WHATSOEVER.

THIS WARRANTY SHALL BE EXTENDED TO COMPLY WITH STATE/PROVINCIAL LAWS AND REQUIREMENTS.

Invacare Corporation www.invacare.com



Yes, you can.

USA
One Invacare Way
Elyria, Ohio USA
44036-2125
800-333-6900

Canada
570 Matheson Blvd E Unit 8
Mississauga Ontario
L4Z 4G4 Canada
800-668-5324

All rights reserved. Trademarks are identified by the symbols [™] and [®]. All trademarks are owned by or licensed to Invacare Corporation unless otherwise noted.

© 2007 Invacare Corporation

Part No. 1145807

Rev B - 10/07