



Cuisine Series Heavy Duty Combination Top Range

Item: _____
 Quantity: _____
 Project: _____
 Approval: _____
 Date: _____

Models:

- C836-12 C0836-12 C0836-12M
 C836-12C C0836-12C C0836-12CM C836-12L C0836-12L C0836-12LM

Range with 2 Open Burners and 12" Even Heat Hot Tops



Model C836-12

Note: Range-based convection oven models can be located in the middle of a battery, banked back-to-back with other equipment, and can be positioned against a wall

Standard Features:

- 12" (305mm) hot top section 25,000 BTUs
- Open top burners 30,000 BTU
- Full-range burner valve control
- One-piece cast iron top grates
- Stainless steel front and sides
- Stainless steel front rail w/position adjustment bar
- 1-1/4" NPT front gas manifold
- Ranges can be installed individually or in a battery
- Automatic lighting - all burners
- 6" (152mm) high stainless steel stub back
- 6" (152mm) chrome steel adj. legs
- Stainless steel oven interior w/removable porcelain bottom
- 40,000 BTU oven burner
- Chrome plated rack with four positions, 1 per oven
- Fully insulated oven interior
- 100% safety oven pilot
- Oven thermostat control - 150°-500°F (66°-260°C)

Optional Features:

- Range base convection oven (add RC)

- Porcelain oven interior in lieu of stainless steel interior - NC
- Single or double deck high shelf or back riser
- Modular unit with legs and shelf (suffix M)
- Modular unit w/o legs on Refrig. Base (change suffix M to PC)
- Stainless steel intermediate shelf for cabinet base
- Stainless steel door(s) for cabinet base units
- Stainless steel back
- Continuous plate shelf, 48-72" for battery installations
- Gas shut-off valves - 3/4", 1", 1 1/4" NPT (Specify size)
- Gas regulator: 3/4" - 1 1/4" NPT (Specify)
- Gas flex hose w/ quick disconnect 3/4", 1", 1 1/4" (Specify)
- Stainless steel legs (set of four)
- Flanged feet set of four
- Swivel casters (4) w/ front locking
- Casters w/ polyurethane wheels - non marking
- Extra oven rack
- Rear Gas Connection; 3/4" NPT (max 250,000 BTU's) or 1-1/4" NPT

Specifications:

U.S. Range Cuisine 36" (914mm) wide Heavy Duty Range Series. Model _____ with total BTU/hr rating of _____ when used with natural/propane gas. Stainless steel front and sides. 6" (152mm) legs with adjustable feet.

Ovens - One piece oven door. Stainless steel oven interior with a heavy-duty, "keep-cool" door handle. Standard oven comes with a thermostat with a temperature range from 150° (low) to 500°F (66°-260°C). One chrome plated oven rack for standard ovens and three for convection ovens.

Open Burners - 30,000 BTU/hr per burner with center pilot and a one piece, cast iron top grate over two open burners.

12" (305mm) Section Hot Tops - 25,000 BTU/hr each burner with one per plate.



NOTE: Ranges supplied with casters must be installed with an approved restraining device.

Cuisine Series Heavy Duty Combination Top Range

Garland Commercial Industries, LLC
185 East South Street
Freeland, PA 18224
Phone: (570) 636-1000
Fax: (570) 636-3903

Garland Commercial Ranges Ltd
1177 Kamato Road,
Mississauga, Ontario
L4W 1X4 CANADA
Phone: 905-624-0260
Fax: 905-624-5669

Enodis UK LTD
Swallowfield Way,
Hayes, Middlesex
UB3 1DQ ENGLAND
Telephone: 081-561-0433
Fax: 081-848-0041

Enodis

Model #*	Description	Total BTU (NAT. Gas)
C836-12*	(2) OB (L) / (2) 12" HT/STD Oven	150,000
C0836-12	(2) OB (L) / (2) 12" HT/Cabinet Base	110,000
C0836-12M	(2) OB (L) / (2) 12" HT/Modular Top	110,000
C836-12C*	(2) OB (C) / (2) 12" HT/STD Oven	150,000
C0236-12C	(2) OB (C) / (2) 12" HT/Cabinet Base	110,000
C0836-12CM	(2) OB (C) / (2) 12" HT/Modular Top	110,000
C836-12R*	(2) OB (R) / (2) 12" HT/STD Oven	150,000
C0836-12R	(2) OB (R) / (2) 12" HT/Cabinet Base	110,000
C0836-12RM	(2) OB (R) / (2) 12" HT/Modular Top	110,000

Individual Burner Ratings (BTU/hr)		
Burner	NAT.	PRO.
Open Top	30,000	28,000
12" Hot Top	25,000	
Std. Oven	40,000	35,000
Conv. Oven	37,000	35,000

Gas Pressure	NAT.	PRO.
Minimum Supply	7" WC	11" WC
Manifold Operating Pressure	6" WC	10" WC
Gas Manifold 1-1/4" NPT		

HT = Hot Top OB = Open Burners
L=Left C=Center R=Right

* Add Suffix "RC" for Convection Oven Base

Interior Dimensions: In (mm)			
Product	Height	Width	Depth
Standard Oven	13-1/2(323)	26-1/4 (667)	29 (737)
Convection	13-1/2(323)	26-1/4 (667)	25 (635)
Cabinet Base	20-1/2 (521)	32-1/4 (819)	31 (787)

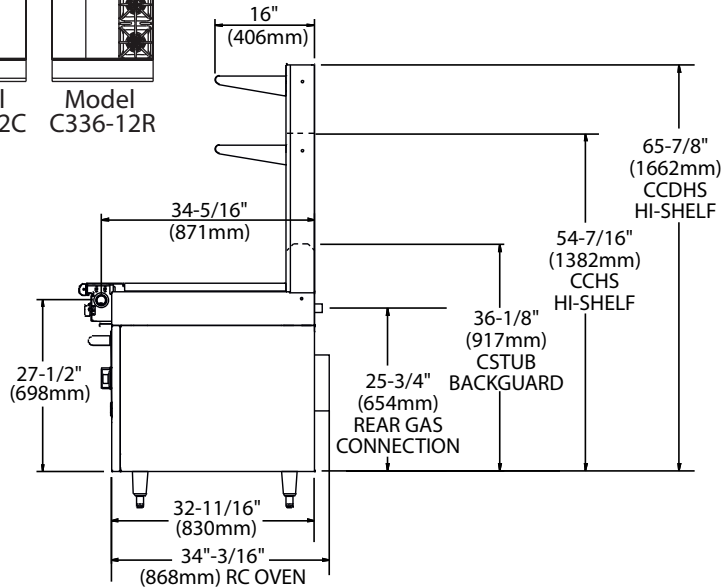
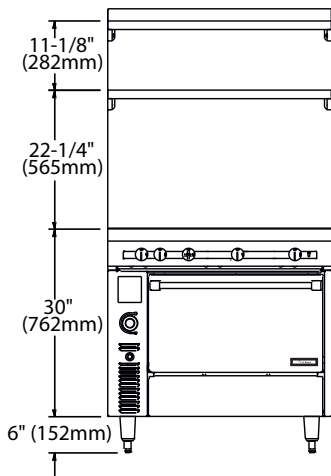
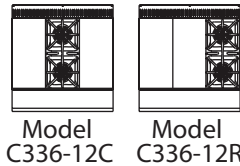
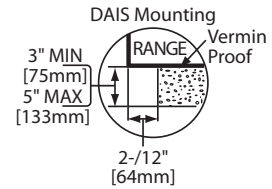
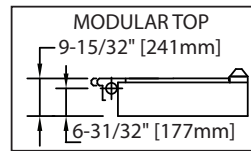
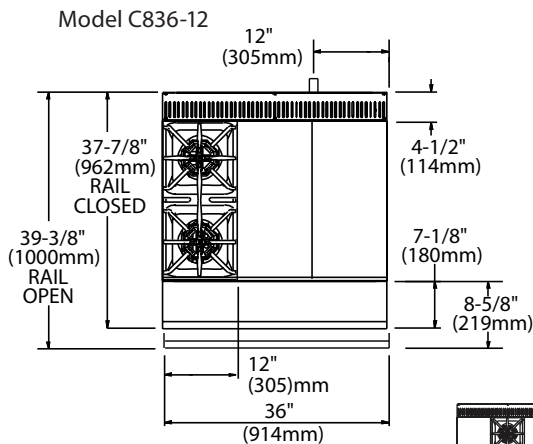

Combustible Wall Clearance	
Sides	Back
6" (152mm)	6" (152mm)

Form# C836-12 (08/07)