



Processes



Multiprocess Welding

Description



Arc Welding Power Source

EXTREME 360 CC/CV Auto-Line

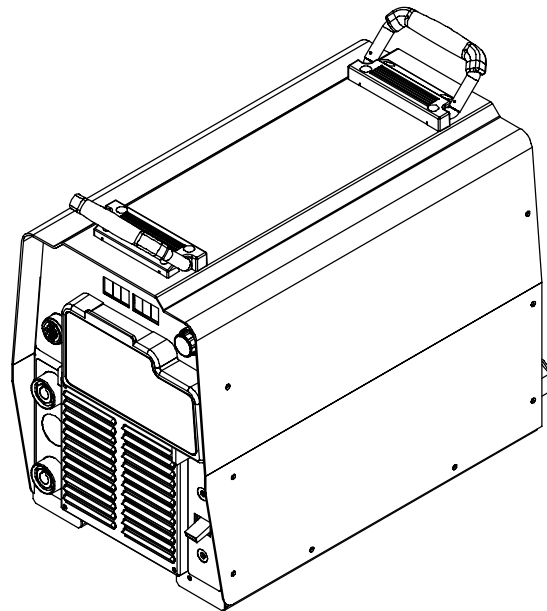

OWNER'S MANUAL

TABLE OF CONTENTS

SECTION 1 – SAFETY PRECAUTIONS - READ BEFORE USING	1
1-1. Symbol Usage	1
1-2. Arc Welding Hazards	1
1-3. Additional Symbols For Installation, Operation, And Maintenance	3
1-4. California Proposition 65 Warnings	4
1-5. Principal Safety Standards	4
1-6. EMF Information	4
SECTION 2 – CONSIGNES DE SÉCURITÉ – LIRE AVANT UTILISATION	5
2-1. Symboles utilisés	5
2-2. Dangers relatifs au soudage à l'arc	5
2-3. Dangers supplémentaires en relation avec l'installation, le fonctionnement et la maintenance	7
2-4. Proposition californienne 65 Avertissements	8
2-5. Principales normes de sécurité	9
2-6. Information EMF	9
SECTION 3 – INTRODUCTION	11
3-1. Specifications	11
3-2. Volt-Ampere Curves	11
3-3. Duty Cycle And Overheating	12
SECTION 4 – INSTALLATION	13
4-1. Dimensions And Weight	13
4-2. Selecting a Location	13
4-3. Connecting 1-Phase Input Power	14
4-4. Connecting 3-Phase Input Power	15
4-5. Electrical Service Guide	16
4-6. Weld Output Receptacles And Selecting Cable Sizes	17
4-7. Remote 14 Receptacle Information	18
4-8. Optional 115 Volts AC Duplex Receptacle And Circuit Breakers	18
4-9. Optional Gas Valve Operation And Shielding Gas Connection	19
SECTION 5 – OPERATION	20
5-1. Front Panel Controls	20
5-2. Meter Functions	21
5-3. Mode Switch Settings	21
5-4. Lift-Arc TIG Procedure	22
5-5. Stick Start Procedure	22
SECTION 6 – MAINTENANCE & TROUBLESHOOTING	23
6-1. Routine Maintenance	23
6-2. Blowing Out Inside Of Unit	23
6-3. Voltmeter/Ammeter Help Displays	24
6-4. Troubleshooting	24
SECTION 7 – ELECTRICAL DIAGRAM	26
SECTION 8 – PARTS LIST	28
WARRANTY	



SECTION 1 – SAFETY PRECAUTIONS - READ BEFORE USING

som_2007-04

 Protect yourself and others from injury — read and follow these precautions.

1-1. Symbol Usage



DANGER! – Indicates a hazardous situation which, if not avoided, will result in death or serious injury. The possible hazards are shown in the adjoining symbols or explained in the text.



Indicates a hazardous situation which, if not avoided, could result in death or serious injury. The possible hazards are shown in the adjoining symbols or explained in the text.

NOTICE – Indicates statements not related to personal injury.

 Indicates special instructions.



This group of symbols means Warning! Watch Out! ELECTRIC SHOCK, MOVING PARTS, and HOT PARTS hazards. Consult symbols and related instructions below for necessary actions to avoid the hazards.

1-2. Arc Welding Hazards



The symbols shown below are used throughout this manual to call attention to and identify possible hazards. When you see the symbol, watch out, and follow the related instructions to avoid the hazard. The safety information given below is only a summary of the more complete safety information found in the Safety Standards listed in Section 1-5. Read and follow all Safety Standards.



Only qualified persons should install, operate, maintain, and repair this unit.



During operation, keep everybody, especially children, away.



ELECTRIC SHOCK can kill.

Touching live electrical parts can cause fatal shocks or severe burns. The electrode and work circuit is electrically live whenever the output is on. The input power circuit and machine internal circuits are also live when power is on. In semiautomatic or automatic wire welding, the wire, wire reel, drive roll housing, and all metal parts touching the welding wire are electrically live. Incorrectly installed or improperly grounded equipment is a hazard.

- Do not touch live electrical parts.
- Wear dry, hole-free insulating gloves and body protection.
- Insulate yourself from work and ground using dry insulating mats or covers big enough to prevent any physical contact with the work or ground.
- Do not use AC output in damp areas, if movement is confined, or if there is a danger of falling.
- Use AC output ONLY if required for the welding process.
- If AC output is required, use remote output control if present on unit.
- Additional safety precautions are required when any of the following electrically hazardous conditions are present: in damp locations or while wearing wet clothing; on metal structures such as floors, gratings, or scaffolds; when in cramped positions such as sitting, kneeling, or lying; or when there is a high risk of unavoidable or accidental contact with the workpiece or ground. For these conditions, use the following equipment in order presented: 1) a semiautomatic DC constant voltage (wire) welder, 2) a DC manual (stick) welder, or 3) an AC welder with reduced open-circuit voltage. In most situations, use of a DC, constant voltage wire welder is recommended. And, do not work alone!
- Disconnect input power or stop engine before installing or servicing this equipment. Lockout/tagout input power according to OSHA 29 CFR 1910.147 (see Safety Standards).
- Properly install and ground this equipment according to its Owner's Manual and national, state, and local codes.

- Always verify the supply ground – check and be sure that input power cord ground wire is properly connected to ground terminal in disconnect box or that cord plug is connected to a properly grounded receptacle outlet.
- When making input connections, attach proper grounding conductor first – double-check connections.
- Keep cords dry, free of oil and grease, and protected from hot metal and sparks.
- Frequently inspect input power cord for damage or bare wiring – replace cord immediately if damaged – bare wiring can kill.
- Turn off all equipment when not in use.
- Do not use worn, damaged, undersized, or poorly spliced cables.
- Do not drape cables over your body.
- If earth grounding of the workpiece is required, ground it directly with a separate cable.
- Do not touch electrode if you are in contact with the work, ground, or another electrode from a different machine.
- Do not touch electrode holders connected to two welding machines at the same time since double open-circuit voltage will be present.
- Use only well-maintained equipment. Repair or replace damaged parts at once. Maintain unit according to manual.
- Wear a safety harness if working above floor level.
- Keep all panels and covers securely in place.
- Clamp work cable with good metal-to-metal contact to workpiece or worktable as near the weld as practical.
- Insulate work clamp when not connected to workpiece to prevent contact with any metal object.
- Do not connect more than one electrode or work cable to any single weld output terminal.

SIGNIFICANT DC VOLTAGE exists in inverter-type welding power sources after removal of input power.

- Turn Off inverter, disconnect input power, and discharge input capacitors according to instructions in Maintenance Section before touching any parts.



HOT PARTS can cause severe burns.

- Do not touch hot parts bare handed.
- Allow cooling period before working on gun or torch.
- To handle hot parts, use proper tools and/or wear heavy, insulated welding gloves and clothing to prevent burns.



FUMES AND GASES can be hazardous.

Welding produces fumes and gases. Breathing these fumes and gases can be hazardous to your health.

- Keep your head out of the fumes. Do not breathe the fumes.
- If inside, ventilate the area and/or use local forced ventilation at the arc to remove welding fumes and gases.
- If ventilation is poor, wear an approved air-supplied respirator.
- Read and understand the Material Safety Data Sheets (MSDSs) and the manufacturer's instructions for metals, consumables, coatings, cleaners, and degreasers.
- Work in a confined space only if it is well ventilated, or while wearing an air-supplied respirator. Always have a trained watchperson nearby. Welding fumes and gases can displace air and lower the oxygen level causing injury or death. Be sure the breathing air is safe.
- Do not weld in locations near degreasing, cleaning, or spraying operations. The heat and rays of the arc can react with vapors to form highly toxic and irritating gases.
- Do not weld on coated metals, such as galvanized, lead, or cadmium plated steel, unless the coating is removed from the weld area, the area is well ventilated, and while wearing an air-supplied respirator. The coatings and any metals containing these elements can give off toxic fumes if welded.



ARC RAYS can burn eyes and skin.

Arc rays from the welding process produce intense visible and invisible (ultraviolet and infrared) rays that can burn eyes and skin. Sparks fly off from the weld.

- Wear an approved welding helmet fitted with a proper shade of filter lenses to protect your face and eyes when welding or watching (see ANSI Z49.1 and Z87.1 listed in Safety Standards).
- Wear approved safety glasses with side shields under your helmet.
- Use protective screens or barriers to protect others from flash, glare and sparks; warn others not to watch the arc.
- Wear protective clothing made from durable, flame-resistant material (leather, heavy cotton, or wool) and foot protection.



WELDING can cause fire or explosion.

Welding on closed containers, such as tanks, drums, or pipes, can cause them to blow up. Sparks can fly off from the welding arc. The flying sparks, hot workpiece, and hot equipment can cause fires and explosions. Accidental contact of electrode to metal objects can cause sparks, explosion, overheating, or fire. Check and be sure the area is safe before doing any welding.

- Remove all flammables within 35 ft (10.7 m) of the welding arc. If this is not possible, tightly cover them with approved covers.
- Do not weld where flying sparks can strike flammable material.
- Protect yourself and others from flying sparks and hot metal.
- Be alert that welding sparks and hot materials from welding can easily go through small cracks and openings to adjacent areas.
- Watch for fire, and keep a fire extinguisher nearby.
- Be aware that welding on a ceiling, floor, bulkhead, or partition can cause fire on the hidden side.
- Do not weld on closed containers such as tanks, drums, or pipes, unless they are properly prepared according to AWS F4.1 (see Safety Standards).
- Do not weld where the atmosphere may contain flammable dust, gas, or liquid vapors (such as gasoline).
- Connect work cable to the work as close to the welding area as practical to prevent welding current from traveling long, possibly unknown paths and causing electric shock, sparks, and fire hazards.

- Do not use welder to thaw frozen pipes.
- Remove stick electrode from holder or cut off welding wire at contact tip when not in use.
- Wear oil-free protective garments such as leather gloves, heavy shirt, cuffless trousers, high shoes, and a cap.
- Remove any combustibles, such as a butane lighter or matches, from your person before doing any welding.
- After completion of work, inspect area to ensure it is free of sparks, glowing embers, and flames.
- Use only correct fuses or circuit breakers. Do not oversize or bypass them.
- Follow requirements in OSHA 1910.252 (a) (2) (iv) and NFPA 51B for hot work and have a fire watcher and extinguisher nearby.

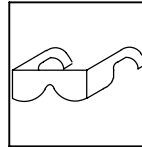

FLYING METAL or DIRT can injure eyes.

- Welding, chipping, wire brushing, and grinding cause sparks and flying metal. As welds cool, they can throw off slag.
- Wear approved safety glasses with side shields even under your welding helmet.



BUILDUP OF GAS can injure or kill.

- Shut off shielding gas supply when not in use.
- Always ventilate confined spaces or use approved air-supplied respirator.

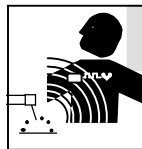

MAGNETIC FIELDS can affect Implanted Medical Devices.

- Wearers of Pacemakers and other Implanted Medical Devices should keep away.
- Implanted Medical Device wearers should consult their doctor and the device manufacturer before going near arc welding, spot welding, gouging, plasma arc cutting, or induction heating operations.

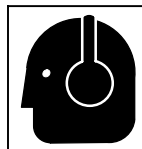

NOISE can damage hearing.

Noise from some processes or equipment can damage hearing.

- Wear approved ear protection if noise level is high.

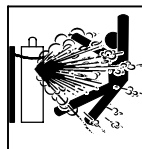

CYLINDERS can explode if damaged.

Shielding gas cylinders contain gas under high pressure. If damaged, a cylinder can explode. Since gas cylinders are normally part of the welding process, be sure to treat them carefully.

- Protect compressed gas cylinders from excessive heat, mechanical shocks, physical damage, slag, open flames, sparks, and arcs.
- Install cylinders in an upright position by securing to a stationary support or cylinder rack to prevent falling or tipping.
- Keep cylinders away from any welding or other electrical circuits.
- Never drape a welding torch over a gas cylinder.
- Never allow a welding electrode to touch any cylinder.
- Never weld on a pressurized cylinder – explosion will result.
- Use only correct shielding gas cylinders, regulators, hoses, and fittings designed for the specific application; maintain them and associated parts in good condition.
- Turn face away from valve outlet when opening cylinder valve.
- Keep protective cap in place over valve except when cylinder is in use or connected for use.
- Use the right equipment, correct procedures, and sufficient number of persons to lift and move cylinders.
- Read and follow instructions on compressed gas cylinders, associated equipment, and Compressed Gas Association (CGA) publication P-1 listed in Safety Standards.

1-3. Additional Symbols For Installation, Operation, And Maintenance



FIRE OR EXPLOSION hazard.

- Do not install or place unit on, over, or near combustible surfaces.
- Do not install unit near flammables.
- Do not overload building wiring – be sure power supply system is properly sized, rated, and protected to handle this unit.



FALLING UNIT can cause injury.

- Use lifting eye to lift unit only, NOT running gear, gas cylinders, or any other accessories.
- Use equipment of adequate capacity to lift and support unit.
- If using lift forks to move unit, be sure forks are long enough to extend beyond opposite side of unit.

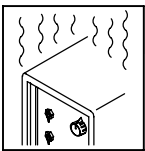

OVERUSE can cause OVERHEATING

- Allow cooling period; follow rated duty cycle.
- Reduce current or reduce duty cycle before starting to weld again.
- Do not block or filter airflow to unit.

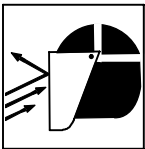

FLYING SPARKS can cause injury.

- Wear a face shield to protect eyes and face.
- Shape tungsten electrode only on grinder with proper guards in a safe location wearing proper face, hand, and body protection.
- Sparks can cause fires — keep flammables away.

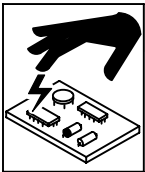

STATIC (ESD) can damage PC boards.

- Put on grounded wrist strap BEFORE handling boards or parts.
- Use proper static-proof bags and boxes to store, move, or ship PC boards.



MOVING PARTS can cause injury.

- Keep away from moving parts.
- Keep away from pinch points such as drive rolls.



WELDING WIRE can cause injury.

- Do not press gun trigger until instructed to do so.
- Do not point gun toward any part of the body, other people, or any metal when threading welding wire.



MOVING PARTS can cause injury.

- Keep away from moving parts such as fans.
- Keep all doors, panels, covers, and guards closed and securely in place.
- Have only qualified persons remove doors, panels, covers, or guards for maintenance as necessary.
- Reinstall doors, panels, covers, or guards when maintenance is finished and before reconnecting input power.

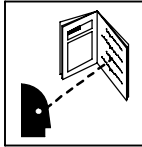

READ INSTRUCTIONS.

- Read Owner's Manual before using or servicing unit.
- Use only genuine replacement parts from the manufacturer.

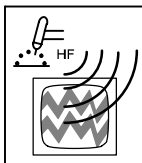

H.F. RADIATION can cause interference.

- High-frequency (H.F.) can interfere with radio navigation, safety services, computers, and communications equipment.
- Have only qualified persons familiar with electronic equipment perform this installation.
- The user is responsible for having a qualified electrician promptly correct any interference problem resulting from the installation.
- If notified by the FCC about interference, stop using the equipment at once.
- Have the installation regularly checked and maintained.
- Keep high-frequency source doors and panels tightly shut, keep spark gaps at correct setting, and use grounding and shielding to minimize the possibility of interference.

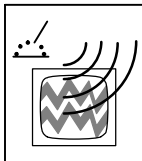

ARC WELDING can cause interference.

- Electromagnetic energy can interfere with sensitive electronic equipment such as computers and computer-driven equipment such as robots.
- Be sure all equipment in the welding area is electromagnetically compatible.
- To reduce possible interference, keep weld cables as short as possible, close together, and down low, such as on the floor.
- Locate welding operation 100 meters from any sensitive electronic equipment.
- Be sure this welding machine is installed and grounded according to this manual.
- If interference still occurs, the user must take extra measures such as moving the welding machine, using shielded cables, using line filters, or shielding the work area.

1-4. California Proposition 65 Warnings

 **Welding or cutting equipment produces fumes or gases which contain chemicals known to the State of California to cause birth defects and, in some cases, cancer. (California Health & Safety Code Section 25249.5 et seq.)**

 **Battery posts, terminals and related accessories contain lead and lead compounds, chemicals known to the State of California to cause cancer and birth defects or other reproductive harm. Wash hands after handling.**

For Gasoline Engines:

 **Engine exhaust contains chemicals known to the State of California to cause cancer, birth defects, or other reproductive harm.**

For Diesel Engines:

 **Diesel engine exhaust and some of its constituents are known to the State of California to cause cancer, birth defects, and other reproductive harm.**

1-5. Principal Safety Standards

Safety in Welding, Cutting, and Allied Processes, ANSI Standard Z49.1, from Global Engineering Documents (phone: 1-877-413-5184, website: www.global.ihs.com).

Recommended Safe Practices for the Preparation for Welding and Cutting of Containers and Piping, American Welding Society Standard AWS F4.1, from Global Engineering Documents (phone: 1-877-413-5184, website: www.global.ihs.com).

National Electrical Code, NFPA Standard 70, from National Fire Protection Association, P.O. Box 9101, Quincy, MA 02269-9101 (phone: 617-770-3000, website: www.nfpa.org and www.sparky.org).

Safe Handling of Compressed Gases in Cylinders, CGA Pamphlet P-1, from Compressed Gas Association, 4221 Walney Road, 5th Floor, Chantilly, VA 20151 (phone: 703-788-2700, website: www.cganet.com).

Code for Safety in Welding and Cutting, CSA Standard W117.2, from Canadian Standards Association, Standards Sales, 5060 Mississauga,

Ontario, Canada L4W 5NS (phone: 800-463-6727 or in Toronto 416-747-4044, website: www.csa-international.org).

Safe Practice For Occupational And Educational Eye And Face Protection, ANSI Standard Z87.1, from American National Standards Institute, 25 West 43rd Street, New York, NY 10036-8002 (phone: 212-642-4900, website: www.ansi.org).

Standard for Fire Prevention During Welding, Cutting, and Other Hot Work, NFPA Standard 51B, from National Fire Protection Association, P.O. Box 9101, Quincy, MA 02269-9101 (phone: 617-770-3000, website: www.nfpa.org).

OSHA, Occupational Safety and Health Standards for General Industry, Title 29, Code of Federal Regulations (CFR), Part 1910, Subpart Q, and Part 1926, Subpart J, from U.S. Government Printing Office, Superintendent of Documents, P.O. Box 371954, Pittsburgh, PA 15250-7954 (phone: 1-866-512-1800) (there are 10 Regional Offices—phone for Region 5, Chicago, is 312-353-2220, website: www.osha.gov).

1-6. EMF Information

Considerations About Welding And The Effects Of Low Frequency Electric And Magnetic Fields

Welding current, as it flows through welding cables, will cause electromagnetic fields. There has been and still is some concern about such fields. However, after examining more than 500 studies spanning 17 years of research, a special blue ribbon committee of the National Research Council concluded that: "The body of evidence, in the committee's judgment, has not demonstrated that exposure to power-frequency electric and magnetic fields is a human-health hazard." However, studies are still going forth and evidence continues to be examined. Until the final conclusions of the research are reached, you may wish to minimize your exposure to electromagnetic fields when welding or cutting.

To reduce magnetic fields in the workplace, use the following procedures:

1. Keep cables close together by twisting or taping them, or using a cable cover.
2. Arrange cables to one side and away from the operator.
3. Do not coil or drape cables around your body.
4. Keep welding power source and cables as far away from operator as practical.
5. Connect work clamp to workpiece as close to the weld as possible.

About Implanted Medical Devices:

Implanted Medical Device wearers should consult their doctor and the device manufacturer before performing or going near arc welding, spot welding, gouging, plasma arc cutting, or induction heating operations. If cleared by your doctor, then following the above procedures is recommended.

SECTION 2 – CONSIGNES DE SÉCURITÉ – LIRE AVANT UTILISATION

fre_som_2007-04

! Se protéger et protéger les autres contre le risque de blessure — lire et respecter ces consignes.

2-1. Symboles utilisés



DANGER! – Indique une situation dangereuse qui si on l'évite pas peut donner la mort ou des blessures graves. Les dangers possibles sont montrés par les symboles joints ou sont expliqués dans le texte.



Indique une situation dangereuse qui si on l'évite pas peut donner la mort ou des blessures graves. Les dangers possibles sont montrés par les symboles joints ou sont expliqués dans le texte.

NOTE – Indique des déclarations pas en relation avec des blessures personnelles.

 Indique des instructions spécifiques.



Ce groupe de symboles veut dire Avertissement! Attention! DANGER DE CHOC ELECTRIQUE, PIECES EN MOUVEMENT, et PIECES CHAUDES. Consulter les symboles et les instructions ci-dessous y afférant pour les actions nécessaires afin d'éviter le danger.

2-2. Dangers relatifs au soudage à l'arc



Les symboles représentés ci-dessous sont utilisés dans ce manuel pour attirer l'attention et identifier les dangers possibles. En présence de l'un de ces symboles, prendre garde et suivre les instructions afférentes pour éviter tout risque. Les instructions en matière de sécurité indiquées ci-dessous ne constituent qu'un sommaire des instructions de sécurité plus complètes fournies dans les normes de sécurité énumérées dans la Section 2-5. Lire et observer toutes les normes de sécurité.



Seul un personnel qualifié est autorisé à installer, faire fonctionner, entretenir et réparer cet appareil.



Pendant le fonctionnement, maintenir à distance toutes les personnes, notamment les enfants de l'appareil.



UNE DÉCHARGE ÉLECTRIQUE peut entraîner la mort.

Le contact d'organes électriques sous tension peut provoquer des accidents mortels ou des brûlures graves. Le circuit de l'électrode et de la pièce est sous tension lorsque le courant est délivré à la sortie. Le circuit d'alimentation et les circuits internes de la machine sont également sous tension lorsque l'alimentation est sur Marche. Dans le mode de soudage avec du fil, le fil, le dérouleur, le bloc de commande du rouleau et toutes les parties métalliques en contact avec le fil sont sous tension électrique. Un équipement installé ou mis à la terre de manière incorrecte ou impropre constitue un danger.

- Ne pas toucher aux pièces électriques sous tension.
- Porter des gants isolants et des vêtements de protection secs et sans trous.
- S'isoler de la pièce à couper et du sol en utilisant des housses ou des tapis assez grands afin d'éviter tout contact physique avec la pièce à couper ou le sol.
- Ne pas se servir de source électrique à courant électrique dans les zones humides, dans les endroits confinés ou là où on risque de tomber.
- Se servir d'une source électrique à courant électrique UNIQUEMENT si le procédé de soudage le demande.
- Si l'utilisation d'une source électrique à courant électrique s'avère nécessaire, se servir de la fonction de télécommande si l'appareil en est équipé.
- D'autres consignes de sécurité sont nécessaires dans les conditions suivantes : risques électriques dans un environnement humide ou si l'on porte des vêtements mouillés ; sur des structures métalliques telles que sols, grilles ou échafaudages ; en position coincée comme assise, à genoux ou couchée ; ou s'il y a un risque élevé de contact inévitable ou accidentel avec la pièce à souder ou le sol. Dans ces conditions, utiliser les équipements suivants, dans l'ordre indiqué : 1) un poste à souder DC à tension constante (à fil), 2) un poste à souder DC manuel (électrode) ou 3) un poste à souder AC à tension à vide réduite. Dans la plupart des situations, l'utilisation d'un poste à souder DC à fil à tension constante est recommandée. En outre, ne pas travailler seul !
- Couper l'alimentation ou arrêter le moteur avant de procéder à l'installation, à la réparation ou à l'entretien de l'appareil. Déverrouiller l'alimentation selon la norme OSHA 29 CFR 1910.147 (voir normes de sécurité).
- Installer le poste correctement et le mettre à la terre convenablement selon les consignes du manuel de l'opérateur et les normes nationales, provinciales et locales.
- Toujours vérifier la terre du cordon d'alimentation. Vérifier et s'assurer que le fil de terre du cordon d'alimentation est bien raccordé à la borne de terre du sectionneur ou que la fiche du cordon est raccordée à une prise correctement mise à la terre.
- En effectuant les raccordements d'entrée, fixer d'abord le conducteur de mise à la terre approprié et contre-vérifier les connexions.
- Les câbles doivent être exempts d'humidité, d'huile et de graisse; protégez-les contre les étincelles et les pièces métalliques chaudes.
- Vérifier fréquemment le cordon d'alimentation afin de s'assurer qu'il n'est pas altéré ou à nu, le remplacer immédiatement s'il l'est. Un fil à nu peut entraîner la mort.
- L'équipement doit être hors tension lorsqu'il n'est pas utilisé.
- Ne pas utiliser des câbles usés, endommagés, de grosseur insuffisante ou mal épissés.
- Ne pas enrouler les câbles autour du corps.
- Si la pièce soudée doit être mise à la terre, le faire directement avec un câble distinct.
- Ne pas toucher l'électrode quand on est en contact avec la pièce, la terre ou une électrode provenant d'une autre machine.
- Ne pas toucher des porte électrodes connectés à deux machines en même temps à cause de la présence d'une tension à vide doublée.
- N'utiliser qu'un matériel en bon état. Réparer ou remplacer sur-le-champ les pièces endommagées. Entretenir l'appareil conformément à ce manuel.
- Porter un harnais de sécurité si l'on doit travailler au-dessus du sol.
- S'assurer que tous les panneaux et couvercles sont correctement en place.
- Fixer le câble de retour de façon à obtenir un bon contact métal-métal avec la pièce à souder ou la table de travail, le plus près possible de la soudure.
- Isoler la pince de masse quand pas mis à la pièce pour éviter le contact avec tout objet métallique.
- Ne pas raccorder plus d'une électrode ou plus d'un câble de masse à une même borne de sortie de soudage.

Il reste une TENSION DC NON NÉGLIGEABLE dans les sources de soudage onduleur quand on a coupé l'alimentation.

- Arrêter les convertisseurs, débrancher le courant électrique et décharger les condensateurs d'alimentation selon les instructions indiquées dans la partie Entretien avant de toucher les pièces.



DES PIÈCES CHAUDES peuvent provoquer des brûlures graves.

- Ne pas toucher à mains nues les parties chaudes.
- Prévoir une période de refroidissement avant de travailler à l'équipement.
- Ne pas toucher aux pièces chaudes, utiliser les outils recommandés et porter des gants de soudage et des vêtements épais pour éviter les brûlures.



LES FUMÉES ET LES GAZ peuvent être dangereux.

Le soudage génère des fumées et des gaz. Leur inhalation peut être dangereux pour votre santé.

- Eloigner votre tête des fumées. Ne pas respirer les fumées.
- À l'intérieur, ventiler la zone et/ou utiliser une ventilation forcée au niveau de l'arc pour l'évacuation des fumées et des gaz de soudage.
- Si la ventilation est médiocre, porter un respirateur anti-vapeurs approuvé.
- Lire et comprendre les spécifications de sécurité des matériaux (MSDS) et les instructions du fabricant concernant les métaux, les consommables, les revêtements, les nettoyants et les dégraissants.
- Travailler dans un espace fermé seulement s'il est bien ventilé ou en portant un respirateur à alimentation d'air. Demander toujours à un surveillant dûment formé de se tenir à proximité. Des fumées et des gaz de soudage peuvent déplacer l'air et abaisser le niveau d'oxygène provoquant des blessures ou des accidents mortels. S'assurer que l'air de respiration ne présente aucun danger.
- Ne pas souder dans des endroits situés à proximité d'opérations de dégraissage, de nettoyage ou de pulvérisation. La chaleur et les rayons de l'arc peuvent réagir en présence de vapeurs et former des gaz hautement toxiques et irritants.
- Ne pas souder des métaux munis d'un revêtement, tels que l'acier galvanisé, plaqué en plomb ou au cadmium à moins que le revêtement n'ait été enlevé dans la zone de soudure, que l'endroit soit bien ventilé, et en portant un respirateur à alimentation d'air. Les revêtements et tous les métaux renfermant ces éléments peuvent dégager des fumées toxiques en cas de soudage.

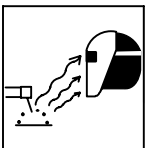

LES RAYONS DE L'ARC peuvent provoquer des brûlures dans les yeux et sur la peau.

Le rayonnement de l'arc du procédé de soudage génère des rayons visibles et invisibles intenses (ultraviolets et infrarouges) susceptibles de provoquer des brûlures dans les yeux et sur la peau. Des étincelles sont projetées pendant le soudage.

- Porter un casque de soudage approuvé muni de verres filtrants appropriés pour protéger visage et yeux pendant le soudage (voir ANSI Z49.1 et Z87.1 énuméré dans les normes de sécurité).
- Porter des lunettes de sécurité avec écrans latéraux même sous votre casque.
- Avoir recours à des écrans protecteurs ou à des rideaux pour protéger les autres contre les rayonnements les éblouissements et les étincelles ; prévenir toute personne sur les lieux de ne pas regarder l'arc.
- Porter des vêtements confectionnés avec des matières résistantes et ignifuges (cuir, coton lourd ou laine) et des bottes de protection.

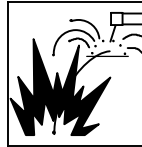

LE SOUDAGE peut provoquer un incendie ou une explosion.

Le soudage effectué sur des conteneurs fermés tel que des réservoirs, tambours ou des conduites peut provoquer leur éclatement. Des étincelles peuvent être projetées de l'arc de soudure. La projection d'étincelles, des pièces chaudes et des équipements chauds peut provoquer des incendies et des brûlures. Le contact accidentel de l'électrode avec des objets métalliques peut provoquer des étincelles, une explosion, un surchauffement ou un incendie. Avant de commencer le soudage, vérifier et s'assurer que l'endroit ne présente pas de danger.

- Déplacer toutes les substances inflammables à une distance de 10,7 m de l'arc de soudage. En cas d'impossibilité les recouvrir soigneusement avec des protections homologués.
- Ne pas souder dans un endroit où des étincelles peuvent tomber sur des substances inflammables.
- Se protéger et d'autres personnes de la projection d'étincelles et de métal chaud.
- Des étincelles et des matériaux chauds du soudage peuvent facilement passer dans d'autres zones en traversant de petites fissures et des ouvertures.
- Surveiller tout déclenchement d'incendie et tenir un extincteur à proximité.
- Le soudage effectué sur un plafond, plancher, paroi ou séparation peut déclencher un incendie de l'autre côté.
- Ne pas effectuer le soudage sur des conteneurs fermés tels que des réservoirs, tambours, ou conduites, à moins qu'ils n'aient été préparés correctement conformément à AWS F4.1 (voir les normes de sécurité).
- Ne soudez pas si l'air ambiant est chargé de particules, gaz, ou vapeurs inflammables (vapeur d'essence, par exemple).
- Brancher le câble de masse sur la pièce la plus près possible de la zone de soudage pour éviter le transport du courant sur une longue distance par des chemins inconnus éventuels en provoquant des risques d'électrocution, d'étincelles et d'incendie.
- Ne pas utiliser le poste de soudage pour dégeler des conduites gelées.
- En cas de non utilisation, enlever la baguette d'électrode du porte-électrode ou couper le fil à la pointe de contact.
- Porter des vêtements de protection dépourvus d'huile tels que des gants en cuir, une chemise en matériau lourd, des pantalons sans revers, des chaussures hautes et un couvre chef.
- Avant de souder, retirer toute substance combustible de vos poches telles qu'un allumeur au butane ou des allumettes.
- Une fois le travail achevé, assurez-vous qu'il ne reste aucune trace d'étincelles incandescentes ni de flammes.
- Utiliser exclusivement des fusibles ou coupe-circuits appropriés. Ne pas augmenter leur puissance; ne pas les ponter.
- Une fois le travail achevé, assurez-vous qu'il ne reste aucune trace d'étincelles incandescentes ni de flammes.
- Utiliser exclusivement des fusibles ou coupe-circuits appropriés. Ne pas augmenter leur puissance; ne pas les ponter.
- Suivre les recommandations dans OSHA 1910.252(a)(2)(iv) et NFPA 51B pour les travaux à chaud et avoir de la surveillance et un extincteur à proximité.

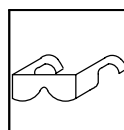

DES PIÈCES DE METAL ou DES SALETES peuvent provoquer des blessures dans les yeux.

- Le soudage, l'écaillage, le passage de la pièce à la brosse en fil de fer, et le meulage génèrent des étincelles et des particules métalliques volantes. Pendant la période de refroidissement des soudures, elles risquent de projeter du laitier.
- Porter des lunettes de sécurité avec écrans latéraux ou un écran facial.



LES ACCUMULATIONS DE GAZ risquent de provoquer des blessures ou même la mort.

- Fermer l'alimentation du gaz protecteur en cas de non-utilisation.
- Veiller toujours à bien aérer les espaces confinés ou se servir d'un respirateur d'adduction d'air homologué.



LES CHAMPS MAGNETIQUES peuvent affecter des implants médicaux.

- Porteur de simulateur cardiaque ou autre implants médicaux, rester à distance.
- Les porteurs d'implants doivent d'abord consulter leur médecin avant de s'approcher des opérations de soudage à l'arc, de soudage par points, de gougeage, du coupage plasma ou de chauffage par induction.

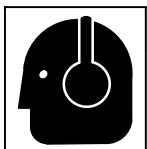

LE BRUIT peut endommager l'ouïe.

Le bruit des processus et des équipements peut affecter l'ouïe.

- Porter des protections approuvées pour les oreilles si le niveau sonore est trop élevé.

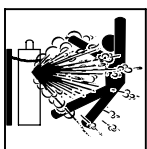

LES BOUTEILLES peuvent exploser si elles sont endommagées.

Des bouteilles de gaz protecteur contiennent du gaz sous haute pression. Si une bouteille est endommagée, elle peut exploser. Du fait que les bouteilles de gaz font normalement partie du procédé de soudage, les manipuler avec précaution.

- Protéger les bouteilles de gaz comprimé d'une chaleur excessive, des chocs mécaniques, des dommages physiques, du laitier, des flammes ouvertes, des étincelles et des arcs.
- Placer les bouteilles debout en les fixant dans un support stationnaire ou dans un porte-bouteilles pour les empêcher de tomber ou de se renverser.
- Tenir les bouteilles éloignées des circuits de soudage ou autres circuits électriques.
- Ne jamais placer une torche de soudage sur une bouteille à gaz.
- Une électrode de soudage ne doit jamais entrer en contact avec une bouteille.
- Ne jamais souder une bouteille pressurisée – risque d'explosion.
- Utiliser seulement des bouteilles de gaz protecteur, régulateurs, tuyaux et raccords convenables pour cette application spécifique ; les maintenir ainsi que les éléments associés en bon état.
- Détourner votre visage du détendeur-régulateur lorsque vous ouvrez la soupape de la bouteille.
- Le couvercle du détendeur doit toujours être en place, sauf lorsque la bouteille est utilisée ou qu'elle est reliée pour usage ultérieur.
- Utiliser les équipements corrects, les bonnes procédures et suffisamment de personnes pour soulever et déplacer les bouteilles.
- Lire et suivre les instructions sur les bouteilles de gaz comprimé, l'équipement connexe et le dépliant P-1 de la CGA (Compressed Gas Association) mentionné dans les principales normes de sécurité.

2-3. Dangers supplémentaires en relation avec l'installation, le fonctionnement et la maintenance



Risque D'INCENDIE OU D'EXPLOSION.

- Ne pas placer l'appareil sur, au-dessus ou à proximité de surfaces inflammables.
- Ne pas installer l'appareil à proximité de produits inflammables.
- Ne pas surcharger l'installation électrique – s'assurer que l'alimentation est correctement dimensionnée et protégée avant de mettre l'appareil en service.

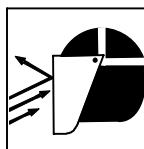

LES ÉTINCELLES VOLANTES risquent de provoquer des blessures.

- Porter un écran facial pour protéger le visage et les yeux.
- Affûter l'électrode au tungstène uniquement à la meuleuse dotée de protecteurs. Cette manœuvre est à exécuter dans un endroit sûr lorsque l'on porte l'équipement homologué de protection du visage, des mains et du corps.
- Les étincelles risquent de causer un incendie – éloigner toute substance inflammable.



LA CHUTE DE L'APPAREIL peut blesser.

- Utiliser l'anneau de levage uniquement pour soulever l'appareil, NON PAS les chariots, les bouteilles de gaz ou tout autre accessoire.
- Utiliser un équipement de levage de capacité suffisante pour lever l'appareil.
- En utilisant des fourches de levage pour déplacer l'unité, s'assurer que les fourches sont suffisamment longues pour dépasser du côté opposé de l'appareil.

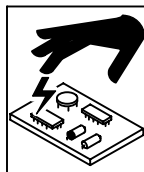

LES CHARGES ÉLECTROSTATIQUES peuvent endommager les circuits imprimés.

- Établir la connexion avec la barrette de terre avant de manipuler des cartes ou des pièces.
- Utiliser des pochettes et des boîtes antistatiques pour stocker, déplacer ou expédier des cartes de circuits imprimés.

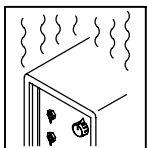

L'EMPLOI EXCESSIF peut SURCHAUFFER L'ÉQUIPEMENT.

- Prévoir une période de refroidissement ; respecter le cycle opératoire nominal.
- Réduire le courant ou le facteur de marche avant de poursuivre le soudage.
- Ne pas obstruer les passages d'air du poste.



DES ORGANES MOBILES peuvent provoquer des blessures.

- Ne pas s'approcher des organes mobiles.
- Ne pas s'approcher des points de coincement tels que des rouleaux de commande.



LES FILS DE SOUDAGE peuvent provoquer des blessures.

- Ne pas appuyer sur la gâchette avant d'en avoir reçu l'instruction.
- Ne pas diriger le pistolet vers soi, d'autres personnes ou toute pièce mécanique en engageant le fil de soudage.



DES ORGANES MOBILES peuvent provoquer des blessures.

- S'abstenir de toucher des organes mobiles tels que des ventilateurs.
- Maintenir fermés et verrouillés les portes, panneaux, recouvrements et dispositifs de protection.
- Seules des personnes qualifiées sont autorisées à enlever les portes, panneaux, recouvrements ou dispositifs de protection pour l'entretien.
- Remettre les portes, panneaux, recouvrements ou dispositifs de protection quand l'entretien est terminé et avant de rebrancher l'alimentation électrique.

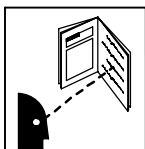

LIRE LES INSTRUCTIONS.

- Lisez le manuel d'instructions avant l'utilisation ou la maintenance de l'appareil.
- N'utiliser que les pièces de rechange recommandées par le constructeur.
- Effectuer régulièrement le contrôle et l'entretien de l'installation.
- Maintenir soigneusement fermés les portes et les panneaux des sources de haute fréquence, maintenir les éclateurs à une distance correcte et utiliser une terre et un blindage pour réduire les interférences éventuelles.

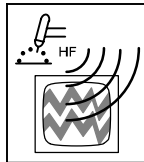

LE RAYONNEMENT HAUTE FRÉQUENCE (H.F.) risque de provoquer des interférences.

- Le rayonnement haute fréquence (H.F.) peut provoquer des interférences avec les équipements de radio-navigation et de communication, les services de sécurité et les ordinateurs.
- Demander seulement à des personnes qualifiées familiarisées avec des équipements électroniques de faire fonctionner l'installation.
- L'utilisateur est tenu de faire corriger rapidement par un électricien qualifié les interférences résultant de l'installation.
- Si le FCC signale des interférences, arrêter immédiatement l'appareil.

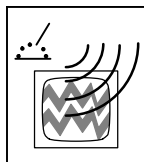

LE SOUDAGE À L'ARC risque de provoquer des interférences.

- L'énergie électromagnétique risque de provoquer des interférences pour l'équipement électronique sensible tel que les ordinateurs et l'équipement commandé par ordinateur tel que les robots.
- Veiller à ce que tout l'équipement de la zone de soudage soit compatible électromagnétiquement.
- Pour réduire la possibilité d'interférence, maintenir les câbles de soudage aussi courts que possible, les grouper, et les poser aussi bas que possible (ex. par terre).
- Veiller à souder à une distance de 100 mètres de tout équipement électronique sensible.
- Veiller à ce que ce poste de soudage soit posé et mis à la terre conformément à ce mode d'emploi.
- En cas d'interférences après avoir pris les mesures précédentes, il incombe à l'utilisateur de prendre des mesures supplémentaires telles que le déplacement du poste, l'utilisation de câbles blindés, l'utilisation de filtres de ligne ou la pose de protecteurs dans la zone de travail.

2-4. Proposition californienne 65 Avertissements



Les équipements de soudage et de coupage produisent des fumées et des gaz qui contiennent des produits chimiques dont l'État de Californie reconnaît qu'ils provoquent des malformations congénitales et, dans certains cas, des cancers. (Code de santé et de sécurité de Californie, chapitre 25249.5 et suivants)



Les batteries, les bornes et autres accessoires contiennent du plomb et des composés à base de plomb, produits chimiques dont l'État de Californie reconnaît qu'ils provoquent des cancers et des malformations congénitales ou autres problèmes de procréation. Se laver les mains après manipulation.

Pour les moteurs à essence :



Les gaz d'échappement des moteurs contiennent des produits chimiques dont l'État de Californie reconnaît qu'ils provoquent des cancers et des malformations congénitales ou autres problèmes de procréation.

Pour les moteurs diesel :



Les gaz d'échappement des moteurs diesel et certains de leurs composants sont reconnus par l'État de Californie comme provoquant des cancers et des malformations congénitales ou autres problèmes de procréation.

2-5. Principales normes de sécurité

Safety in Welding, Cutting, and Allied Processes, ANSI Standard Z49.1, de Global Engineering Documents (téléphone : 1-877-413-5184, site Internet : www.global.ihc.com).

Recommended Safe Practices for the Preparation for Welding and Cutting of Containers and Piping, American Welding Society Standard AWS F4.1 de Global Engineering Documents (téléphone : 1-877-413-5184, site Internet : www.global.ihc.com).

National Electrical Code, NFPA Standard 70, de National Fire Protection Association, P.O. Box 9101, Quincy, MA 02269-9101 (téléphone : 617-770-3000, site Internet : www.nfpa.org).

Safe Handling of Compressed Gases in Cylinders, CGA Pamphlet P-1, de Compressed Gas Association, 4221 Walney Road, 5th Floor, Chantilly, VA 20151 (téléphone : 703-788-2700, site Internet : www.cganet.com).

Code for Safety in Welding and Cutting, CSA Standard W117.2, de Canadian Standards Association, 5060 Mississauga, Ontario, Canada

L4W 5NS (téléphone : 800-463-6727 ou à Toronto 416-747-4044, site Internet : www.csa-international.org).

Safe Practice For Occupational And Educational Eye And Face Protection, ANSI Standard Z87.1, de American National Standards Institute, 11 West 43rd Street, New York, NY 10036-8002 (téléphone : 212-642-4900, site Internet : www.ansi.org).

Standard for Fire Prevention During Welding, Cutting, and Other Hot Work, NFPA Standard 51B, de National Fire Protection Association, P.O. Box 9101, Quincy, MA 02269-9101 (téléphone : 617-770-3000, site Internet : www.nfpa.org).

OSHA, Occupational Safety and Health Standards for General Industry, Title 29, Code of Federal Regulations (CFR), Part 1910, Subpart Q, and Part 1926, Subpart J, de U.S. Government Printing Office, Superintendent of Documents, P.O. Box 371954, Pittsburgh, PA 15250-7954 (téléphone : 1-866-512-1800) (il y a 10 bureaux régionaux—le téléphone de la région 5, Chicago, est 312-353-2220, site Internet : www.osha.gov).

2-6. Information EMF

Considérations sur le soudage et les effets de basse fréquence et des champs magnétiques et électriques.

Le courant de soudage, pendant son passage dans les câbles de soudage, causera des champs électromagnétiques. Il y a eu et il y a encore un certain souci à propos de tels champs. Cependant, après avoir examiné plus de 500 études qui ont été faites pendant une période de recherche de 17 ans, un comité spécial ruban bleu du National Research Council a conclu : « L'accumulation de preuves, suivant le jugement du comité, n'a pas démontré que l'exposition aux champs magnétiques et champs électriques à haute fréquence représente un risque à la santé humaine ». Toutefois, des études sont toujours en cours et les preuves continuent à être examinées. En attendant que les conclusions finales de la recherche soient établies, il vous serait souhaitable de réduire votre exposition aux champs électromagnétiques pendant le soudage ou le coupage.

Pour réduire les champs magnétiques sur le poste de travail, appliquer les procédures suivantes :

1. Garder les câbles ensemble, les torsader, les scotcher, ou les recouvrir d'une housse.
2. Disposer les câbles d'un côté et à distance de l'opérateur.
3. Ne pas courber pas et ne pas entourer pas les câbles autour de votre corps.
4. Garder le poste de soudage et les câbles le plus loin possible de vous.
5. Connecter la pince sur la pièce aussi près que possible de la soudure.

En ce qui concerne les implants médicaux :

Les porteurs d'implants doivent d'abord consulter leur médecin avant de s'approcher des opérations de soudage à l'arc, de soudage par points, de gougeage, du coupage plasma ou de chauffage par induction. Si le médecin approuve, il est recommandé de suivre les procédures précédentes.

SECTION 3 – INTRODUCTION

3-1. Specifications

Input Power	Rated Output	Voltage Range in CV Mode	Amperage Range in CC Mode	Max. Open-Circuit Voltage	RMS Amps Input at Rated Load Output, 60 Hz 3-Phase at NEMA Load Voltages and Class I Rating					KVA	KW
					208 V	230 V	400 V	460 V	575 V		
3-Phase	350 A at 34 VDC, 60% Duty Cycle	10–38 V	5–425 A	75 VDC	40.4	36.1	20.6	17.8	14.1	14.2	13.6
1-Phase	300 A at 32 VDC, 60% Duty Cycle*				60.8	54.6	29.7	25.4	19.9	11.7	11.2

*See Section 3-3 for Duty Cycle Rating.

3-2. Volt-Ampere Curves

A. CC Mode

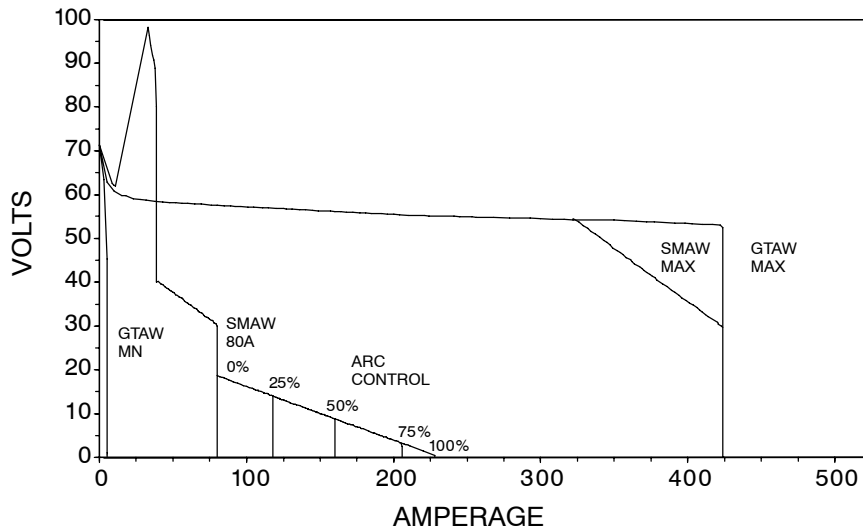

Volt-ampere curves show minimum and maximum voltage and amperage output capabilities of welding power source. Curves of other settings fall between curves shown.

B. CV Mode

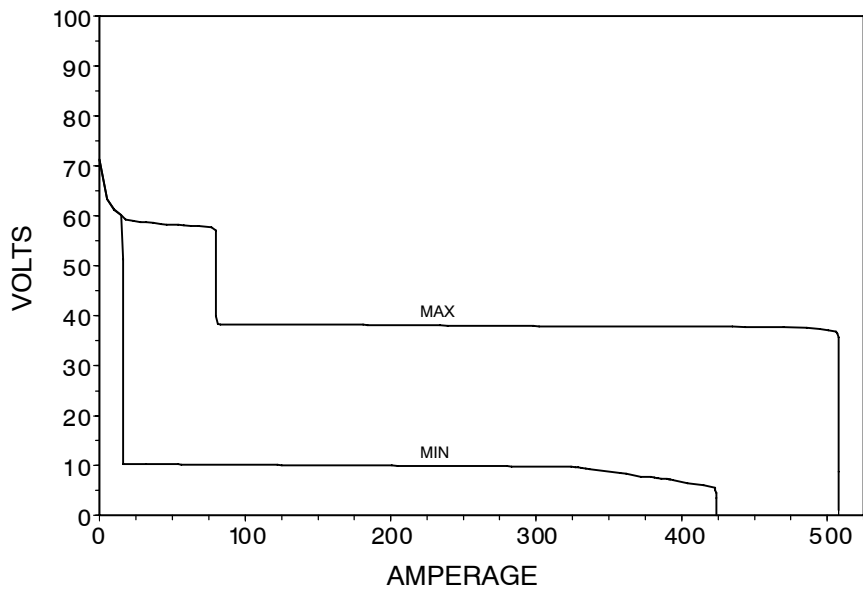

3-3. Duty Cycle And Overheating



Duty Cycle is percentage of 10 minutes that unit can weld at rated load without overheating.

If unit overheats, output stops, a Help message is displayed and cooling fan runs. Wait fifteen minutes for unit to cool. Reduce amperage or voltage, or duty cycle before welding.

Single Phase Operation: The unit is supplied with a 8 AWG power cord. The rated output with 8 AWG is 300 amps, 32 volts at 40% duty cycle. To achieve 60% duty cycle change cord to 6 AWG.

NOTICE - Exceeding duty cycle can damage unit and void warranty.

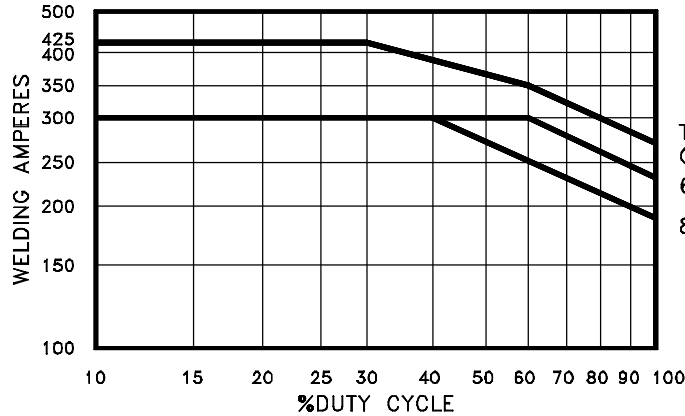

THREE PHASE OPERATION
 6AWG POWER CORD } SINGLE PHASE OPERATION
 8AWG POWER CORD }

60% Duty Cycle

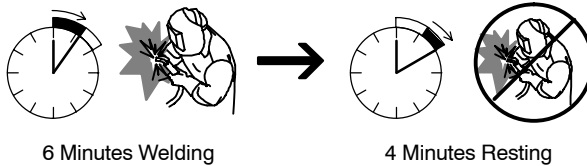

Overheating

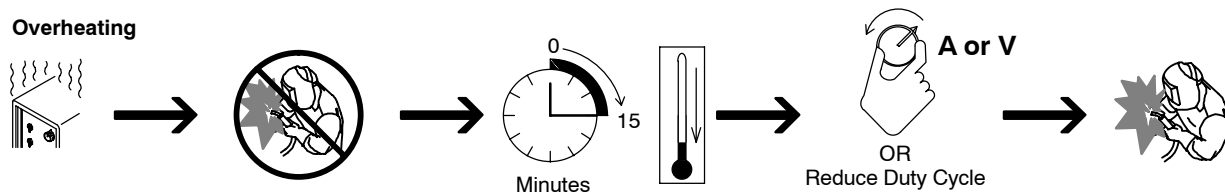

Ref. 216 568-A

Notes

SECTION 4 – INSTALLATION

4-1. Dimensions And Weight

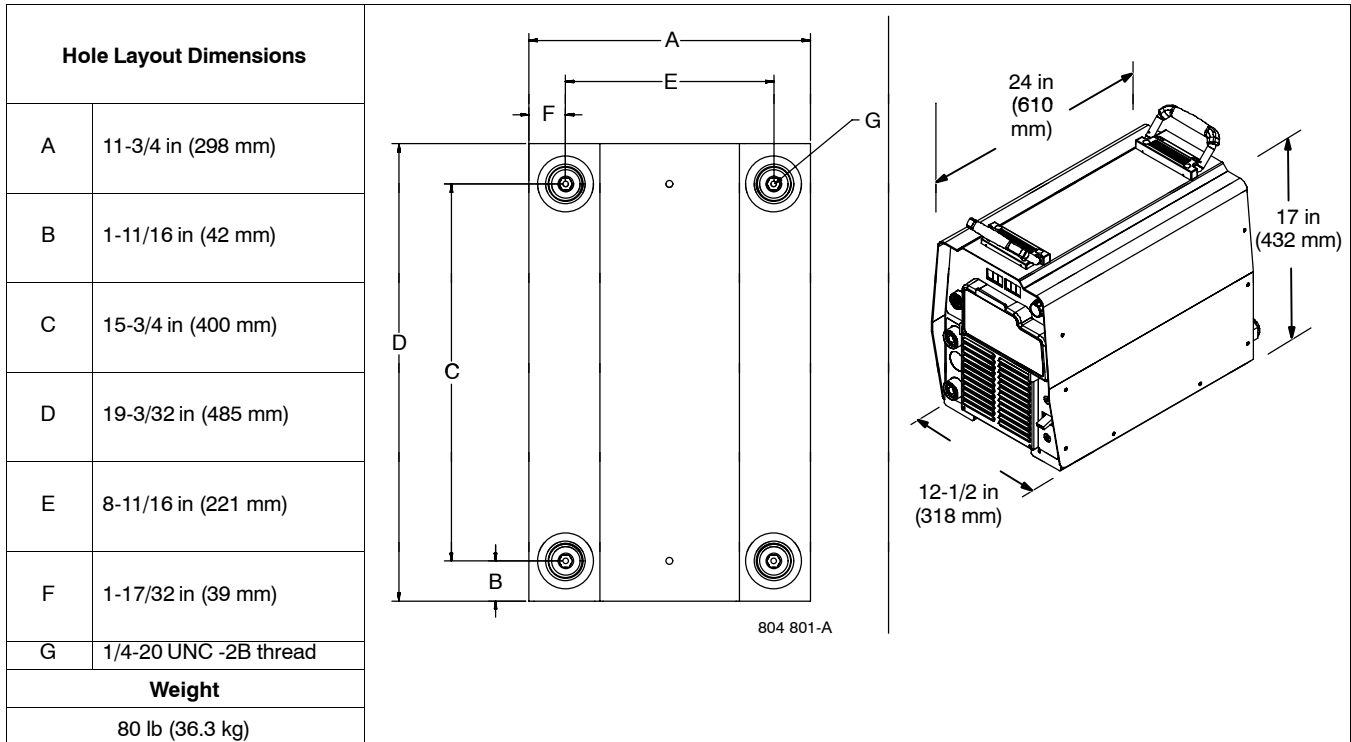

4-2. Selecting a Location

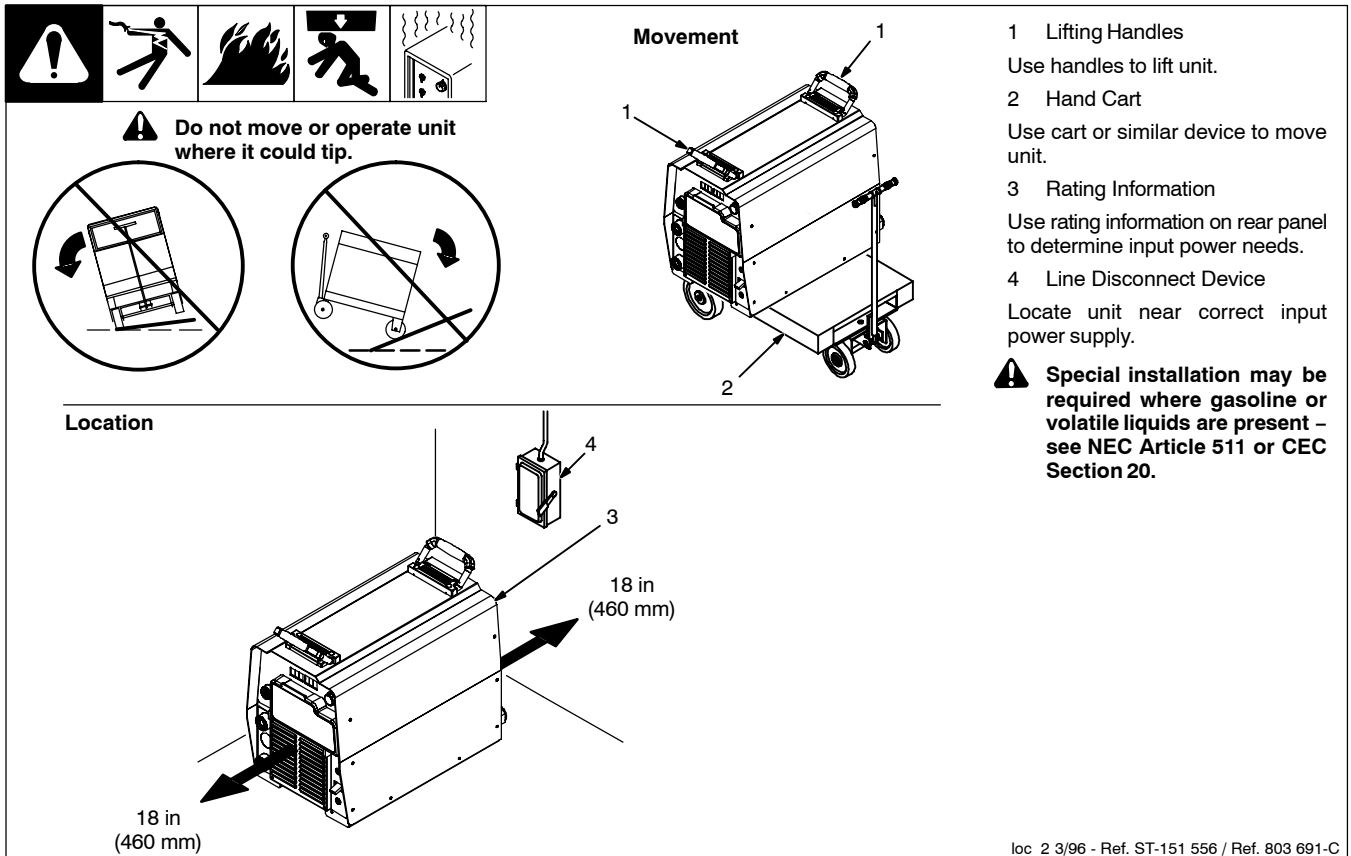

4-3. Connecting 1-Phase Input Power

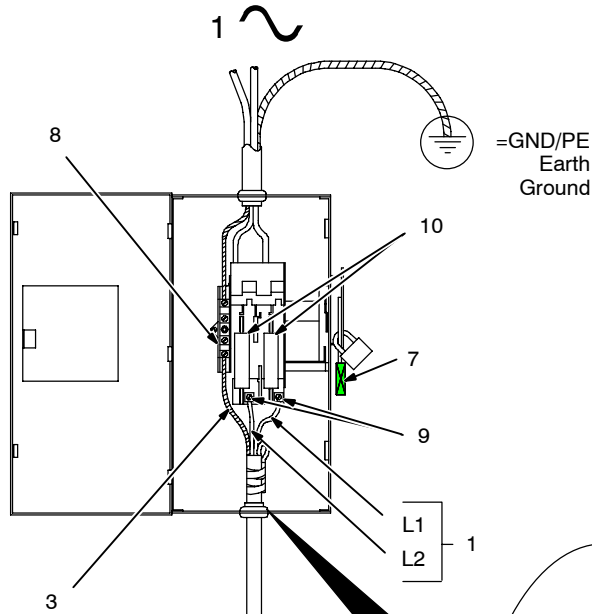

=GND/PE
Earth
Ground

L1
L2

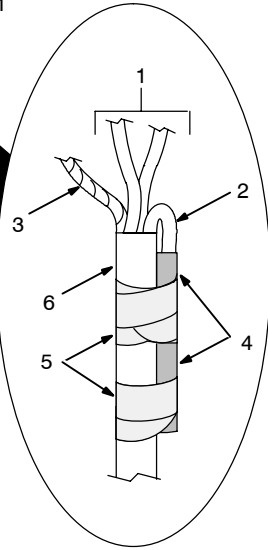

- ⚠** Installation must meet all National and Local Codes – have only qualified persons make this installation.
- ⚠** Disconnect and lockout/tagout input power before connecting input conductors from unit.
- ⚠** Always connect green or green/yellow conductor to supply grounding terminal first, and never to a line terminal.

☞ The Auto-Line circuitry in this unit automatically adapts the power source to the primary voltage being applied. Check input voltage available at site. This unit can be connected to any input power between 208 and 575 VAC without removing cover to relink the power source.

- 1 Black And White Input Conductor (L1 And L2)
- 2 Red Input Conductor
- 3 Green Or Green/Yellow Grounding Conductor
- 4 Insulation Sleeving
- 5 Electrical Tape

Insulate and isolate red conductor as shown.

- 6 Input Power Cord.
- 7 Disconnect Device (switch shown in the OFF position)
- 8 Disconnect Device Grounding Terminal
- 9 Disconnect Device Line Terminals

Connect green or green/yellow grounding conductor to disconnect device grounding terminal first.

Connect input conductors L1 and L2 to disconnect device line terminals.

- 10 Overcurrent Protection

Select type and size of overcurrent protection using Section 4-5 (fused disconnect switch shown).

Close and secure door on disconnect device. Remove lockout/tagout device, and place switch in the On position.

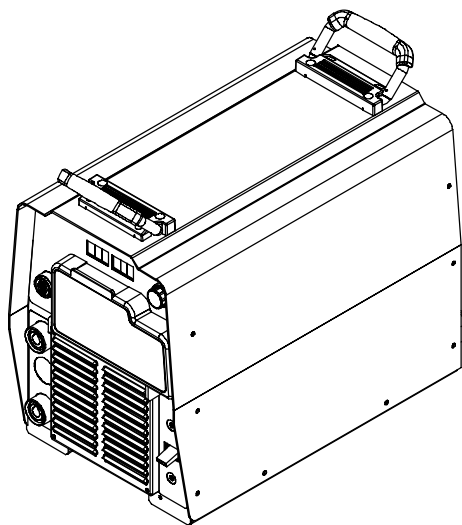

Tools Needed:



804 531-A

4-4. Connecting 3-Phase Input Power

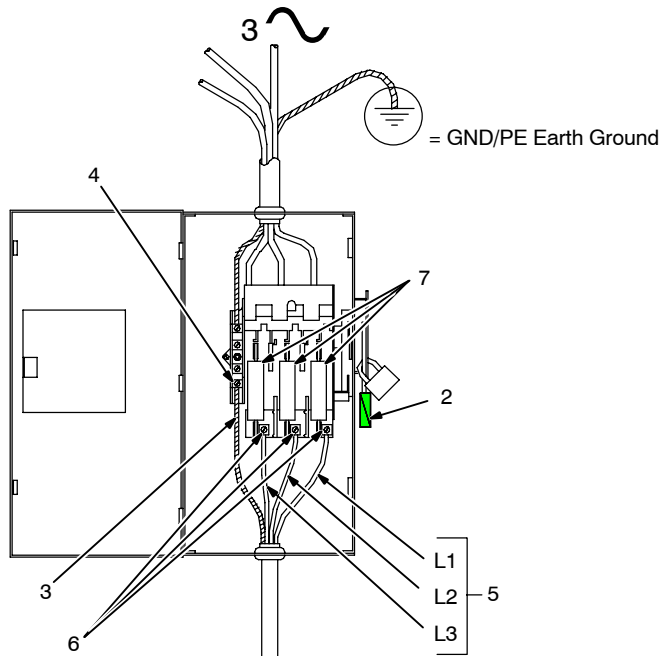

⚠ Installation must meet all National and Local Codes – have only qualified persons make this installation.

⚠ Disconnect and lockout/tagout input power before connecting input conductors from unit.

⚠ Always connect green or green/yellow conductor to supply grounding terminal first, and never to a line terminal.

ℹ The Auto-Line circuitry in this unit automatically adapts the power source to the primary voltage being applied. Check input voltage available at site. This unit can be connected to any input power between 208 and 575 VAC without removing cover to relink the power source.

For Three-Phase Operation

- 1 Input Power Cord.
- 2 Disconnect Device (switch shown in the OFF position)
- 3 Green Or Green/Yellow Grounding Conductor
- 4 Disconnect Device Grounding Terminal
- 5 Input Conductors (L1, L2 And L3)
- 6 Disconnect Device Line Terminals

Connect green or green/yellow grounding conductor to disconnect device grounding terminal first.

Connect input conductors L1, L2, and L3 to disconnect device line terminals.

7 Overcurrent Protection

Select type and size of overcurrent protection using Section 4-5 (fused disconnect switch shown).

Close and secure door on disconnect device. Remove lockout/tagout device, and place switch in the On position.

Tools Needed:

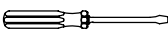

4-5. Electrical Service Guide

NOTICE – INCORRECT INPUT POWER can damage this welding power source. Phase to ground voltage shall not exceed +10% of rated input voltage.

NOTICE – Actual input voltage should not be 10% less than minimum and/or 10% more than maximum input voltages listed in table. If actual input voltage is outside this range, output may not be available.

⚠ Failure to follow these electrical service guide recommendations could create an electric shock or fire hazard. These recommendations are for a dedicated branch circuit sized for the rated output and duty cycle of the welding power source.

Input Voltage	Single-Phase				
	208	230	400	460	575
Input Amperes At Rated Output	60.8	54.6	29.7	25.4	19.9
Max Recommended Standard Fuse Rating In Amperes ¹	70 60 35 30 25				
Time-Delay ²					
Normal Operating ³	80	80	45	40	30
Min Input Conductor Size In AWG/Kcmil ⁴	8	8	10	12	12
Max Recommended Input Conductor Length In Feet (Meters)	72 (22)	89 (27)	176 (54)	140 (43)	219 (67)
Min Grounding Conductor Size In AWG/Kcmil ⁴	8	8	10	12	12

Input Voltage	Three-Phase				
	208	230	400	460	575
Input Amperes At Rated Output	40.4	36.1	20.6	17.8	14.1
Max Recommended Standard Fuse Rating In Amperes ¹	45 40 25 20 15				
Time-Delay ²					
Normal Operating ³	60	50	30	25	20
Min Input Conductor Size In AWG/Kcmil ⁴	8	10	12	14	14
Max Recommended Input Conductor Length In Feet (Meters)	119 (36)	96 (29)	175 (53)	150 (46)	234 (71)
Min Grounding Conductor Size In AWG/Kcmil ⁴	10	10	12	14	14

Reference: 2005 National Electrical Code (NEC) (including article 630)

1 Consult factory for circuit breaker applications.

2 "Time-Delay" fuses are UL class "RK5" .

3 "Normal Operating" (general purpose - no intentional delay) fuses are UL class "K5" (up to and including 60 amp), and UL class "H" (65 amp and above).

4 Conductor data in this section specifies conductor size (excluding flexible cord or cable) between the panelboard and the equipment per NEC Table 310.16. If a flexible cord or cable is used, minimum conductor size may increase. See NEC Table 400.5(A) for flexible cord and cable requirements.

4-6. Weld Output Receptacles And Selecting Cable Sizes



⚠️ ARC WELDING can cause Electromagnetic Interference.

To reduce possible interference, keep weld cables as short as possible, close together, and down low, such as on the floor. Locate welding operation 100 meters from any sensitive electronic equipment. Be sure this welding machine is installed and grounded according to this manual. If interference still occurs, the user must take extra measures such as moving the welding machine, using shielded cables, using line filters, or shielding the work area.



Weld Output Terminals

⚠️ Turn off power before connecting to weld output terminals.

⚠️ Do not use worn, damaged, undersized, or poorly spliced cables.

Weld Cable Size** and Total Cable (Copper) Length in Weld Circuit Not Exceeding***

Welding Amperes	Weld Cable Size** and Total Cable (Copper) Length in Weld Circuit Not Exceeding***								
	100 ft (30 m) or Less		150 ft (45 m)	200 ft (60 m)	250 ft (70 m)	300 ft (90 m)	350 ft (105 m)	400 ft (120 m)	
	10 – 60% Duty Cycle	60 – 100% Duty Cycle	10 – 100% Duty Cycle						
100	4	4	4	3	2	1	1/0	1/0	
150	3	3	2	1	1/0	2/0	3/0	3/0	
200	3	2	1	1/0	2/0	3/0	4/0	4/0	
250	2	1	1/0	2/0	3/0	4/0	2-2/0	2-2/0	
300	1	1/0	2/0	3/0	4/0	2-2/0	2-3/0	2-3/0	
350	1/0	2/0	3/0	4/0	2-2/0	2-3/0	2-3/0	2-4/0	
400	1/0	2/0	3/0	4/0	2-2/0	2-3/0	2-4/0	2-4/0	
500	2/0	3/0	4/0	2-2/0	2-3/0	2-4/0	3-3/0	3-3/0	
600	3/0	4/0	2-2/0	2-3/0	2-4/0	3-3/0	3-4/0	3-4/0	

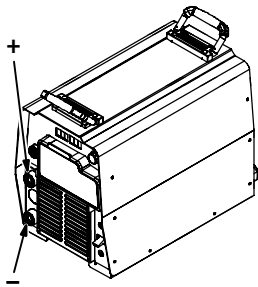

Output Receptacles





* This chart is a general guideline and may not suit all applications. If cable overheats, use next size larger cable.

**Weld cable size (AWG) is based on either a 4 volts or less drop or a current density of at least 300 circular mils per ampere.
() = mm² for metric use

S-0007-F-

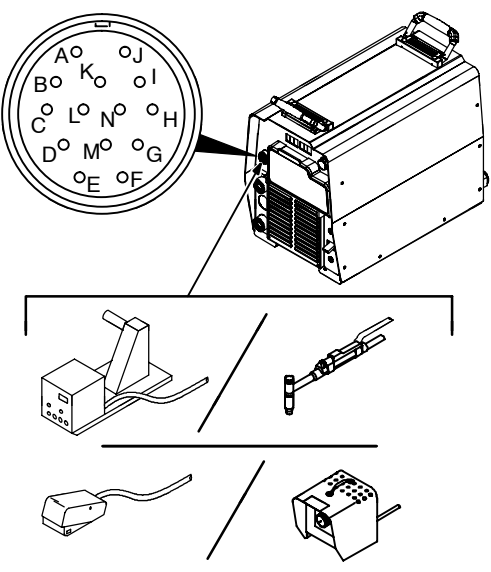
***For distances longer than those shown in this guide, call a factory applications representative at 920-735-4505.

4-7. Remote 14 Receptacle Information

	 REMOTE 14	Socket*	Socket Information
	24 VOLTS AC  OUTPUT (CONTACTOR)	115 VOLTS AC  OUTPUT (CONTACTOR)	A
B			Contact closure to A completes 24 volts ac contactor control circuit.
REMOTE OUTPUT CONTROL	C	Output to remote control; 0 to +10 volts dc, +10 volts dc in MIG mode.	
	D	Remote control circuit common.	
	E	0 to +10 volts dc input command signal from remote control.	
A/V AMPERAGE VOLTAGE	M	CC/CV select	
	F	Current feedback; +1 volt dc per 100 amperes.	
GND	H	Voltage feedback; +1 volt dc per 10 output receptacle volts.	
	G	Circuit common for 24 and 115 volts ac circuits.	
		K	Chassis common.

*The remaining sockets are not used.

4-8. Optional 115 Volts AC Duplex Receptacle And Circuit Breakers

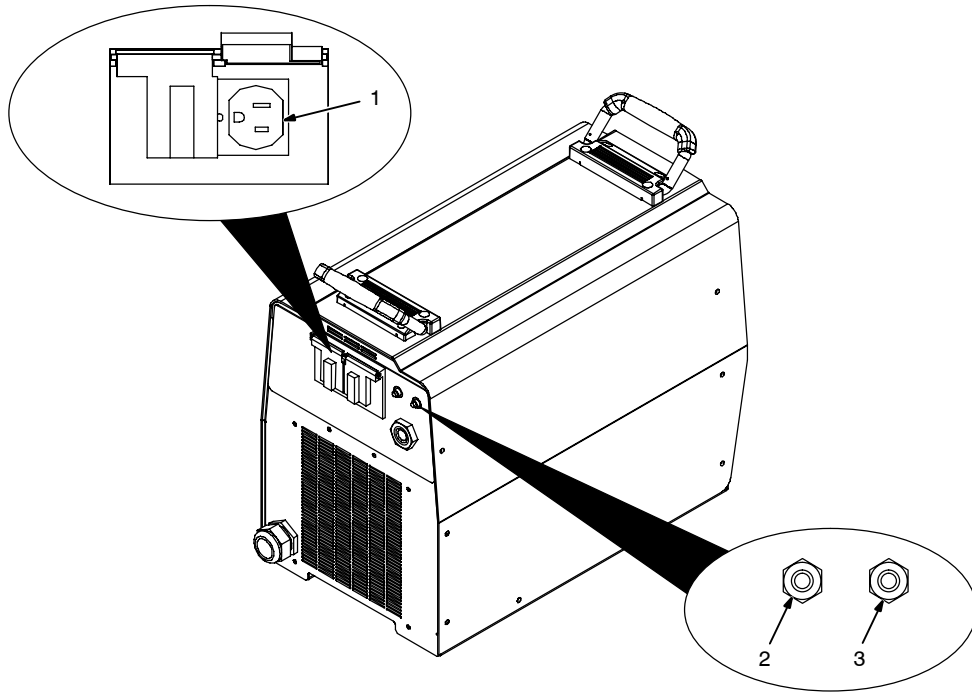

1 115 V 10 Amp AC Receptacle
 Power is shared between duplex receptacle and Remote 14 receptacle (see Section 4-7).

2 Circuit Breaker CB1
 3 Circuit Breaker CB2

CB1 protects duplex receptacle and 115 volts ac portion of Remote 14 receptacle from overload.

CB2 protects 24 volts ac portion of Remote 14 receptacle from overload.

Press button to reset breaker.

803 691-C

4-9. Optional Gas Valve Operation And Shielding Gas Connection

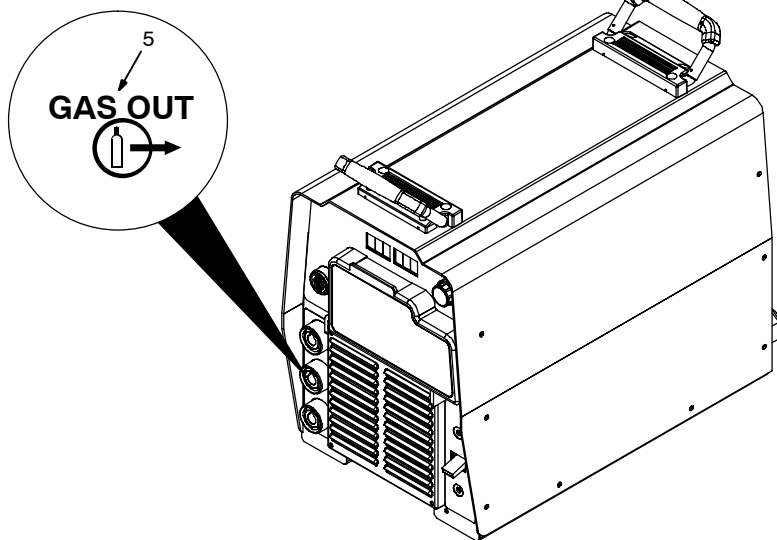
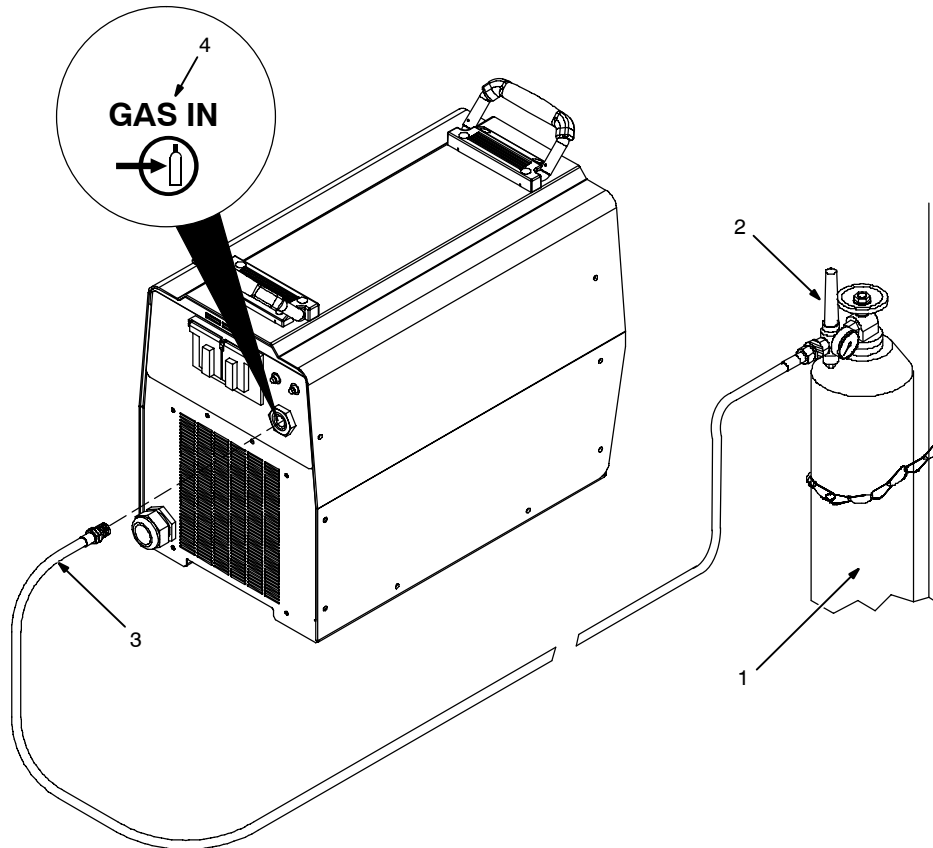

Obtain gas cylinder and chain to running gear, wall, or other stationary support so cylinder cannot fall and break off valve.

- 1 Cylinder
- 2 Regulator/Flowmeter
- 3 Gas Hose Connection

Fitting has 5/8-18 right-hand threads. Obtain and install gas hose.

- 4 Gas In Fitting
- 5 Gas Out Fitting

The Gas In and Gas Out fittings have 5/8-18 right-hand threads. Obtain proper size, type, and length hose and make connections as follows:

Connect hose from shielding gas supply regulator/flowmeter to Gas In fitting.

Connect hose coupler to torch. Connect one end of gas hose to hose coupler. Connect remaining end of gas hose to Gas Out fitting.

Operation

The gas solenoid controls gas flow during the TIG process as follows:

Remote TIG

Gas flow starts with remote contactor on.

Gas flow stops at end of post-flow if current was detected, or with remote contactor off if no current was detected.

Lift-Arc TIG

Gas flow starts when tungsten touches work (touch sensed).

Gas flow stops at end of post-flow.

Scratch Start TIG

Gas flow starts when current is detected.

Gas flow stops at end of post-flow.

Post-flow time is factory set to 5 seconds per 100 amps of weld current. The minimum post-flow time is 5 seconds. The maximum post-flow is 20 seconds (post flow settings are not adjustable by the end user).

SECTION 5 – OPERATION

5-1. Front Panel Controls

1 Power Switch

 The fan motor is thermostatically controlled and only runs when cooling is needed.

2 Voltmeter

3 Ammeter

4 V/A (Voltage/Amperage) Adjustment Control

5 Mode Switch

The Mode switch setting determines both the process and output On/Off control (see Section 5-3).

For Air Carbon Arc (CAC-A) cutting and gouging, place switch in Stick position. For best results, place Arc Control in the maximum position.

tion.

6 Remote 14 Receptacle

For remote control, make connections to Remote 14 receptacle. In TIG modes and the REMOTE STICK mode, remote control is a percent of V/A Adjust control setting (value selected on V/A Adjust is maximum available on remote). In ELECTRODE HOT mode the remote control is not used. In the MIG mode, remote control provides full range of unit output regardless of V/A Adjust control setting.

7 Arc Control

Control adjusts Dig when Stick or CC mode is selected on mode switch. When set towards minimum, short-circuit amperage at low arc

voltage is the same as normal welding amperage.

When set towards maximum, short-circuit amperage is increased at low arc voltage to assist with arc starts as well as reduce sticking while welding.

Select setting best suited for application.

Control adjusts inductance when MIG or V-Sense Feeder position is selected on the mode switch. Inductance determines the “wetness” of the weld puddle. When set towards maximum, “wetness” (puddle fluidity) increases.

When Pulsed MIG or one of the TIG modes is selected, this control is not functional.

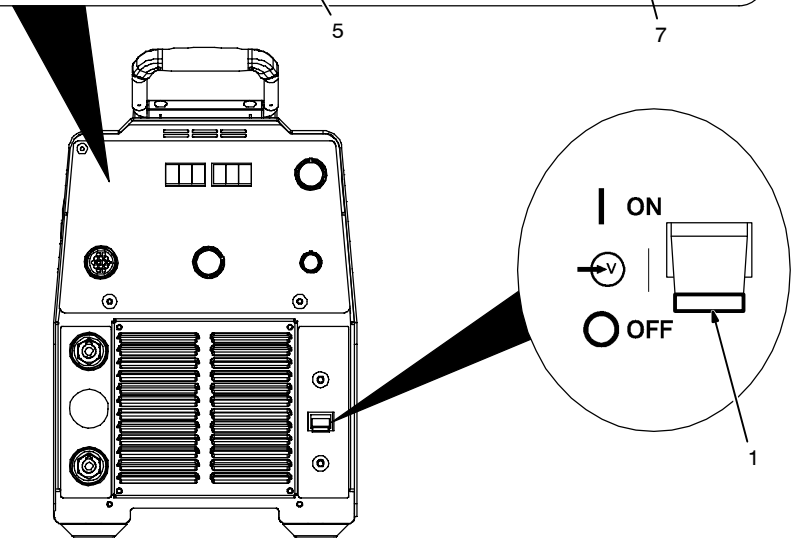
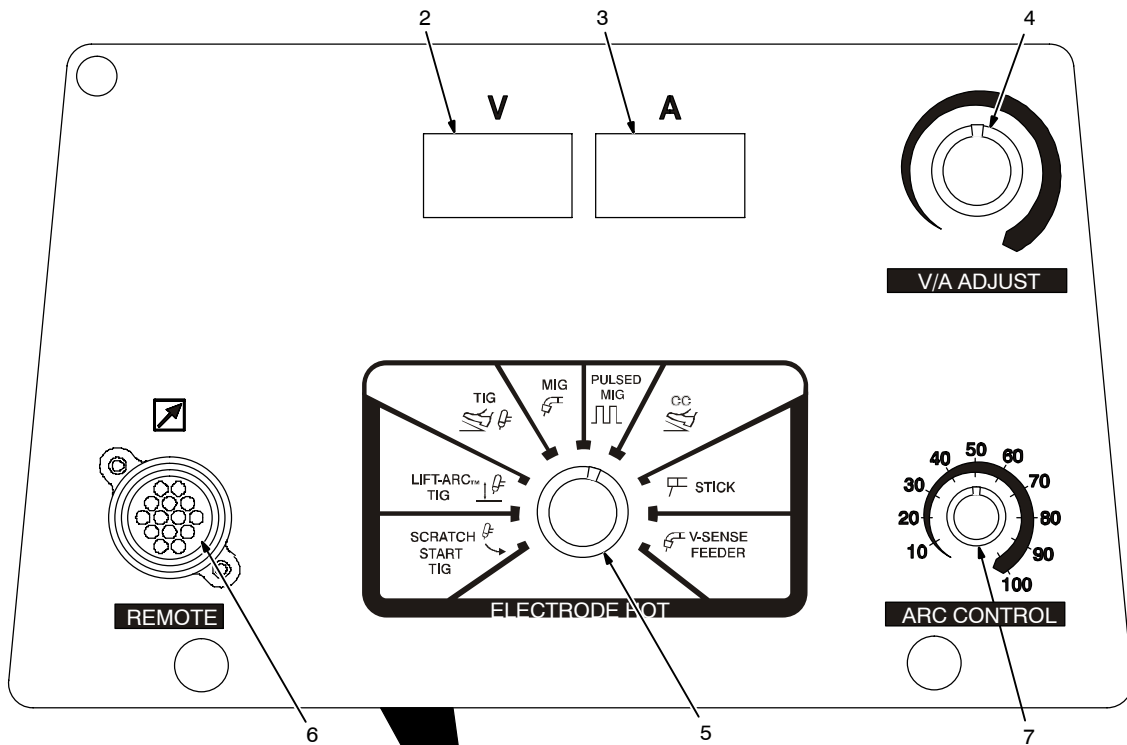

Ref. 803 692-B / Ref. 212 064

5-2. Meter Functions

 The meters display the actual weld output values for approximately three seconds after the arc is broken.

Mode	Meter Reading At Idle		Meter Reading While Welding	
	V	A	V	A
Scratch Start TIG	71.7 Actual Volts (OCV)	85 Preset Amps	10.3 Actual Volts	85 Actual Amps
Lift-Arc TIG	14.1 Actual Volts	85 Preset Amps	10.3 Actual Volts	85 Actual Amps
TIG	Blank	85 Preset Amps	10.3 Actual Volts	85 Actual Amps
MIG	24.5 Preset Volts	Blank	24.5 Actual Volts	250 Actual Amps
Pulsed MIG	PPP Pulse Display	PPP Pulse Display	24.5 Actual Volts	250 Actual Amps
CC	Blank	85 Preset Amps	24.5 Actual Volts	85 Actual Amps
Stick	71.7 Actual Volts (OCV)	85 Preset Amps	24.5 Actual Volts	85 Actual Amps
V-Sense Feeder	71.7 Flashes OCV And Preset	Blank	24.5 Actual Volts	250 Actual Amps

5-3. Mode Switch Settings

 The Stick and CC modes provide the Adaptive Hot Start™ feature, which automatically increases the output amperage at the start of a weld should the start require it. This eliminates electrode sticking at arc start.

Mode Switch Setting	Process	Output On/Off Control
Scratch Start TIG	GTAW	Electrode Hot
Lift-Arc TIG	GTAW – See Section 5-4	Electrode Hot
TIG	GTAW With HF Unit, Pulsing Device, Or Remote Control	At Remote 14
MIG	GMAW	At Remote 14
Pulsed MIG	GMAW-P (Requires an external pulsing device.)	At Remote 14
CC	Stick (SMAW) With Remote On/Off	At Remote 14
Stick	SMAW	Electrode Hot
V-Sense Feeder	MIG (GMAW) With Voltage Sensing Wire Feeder	Electrode Hot

5-4. Lift-Arc TIG Procedure

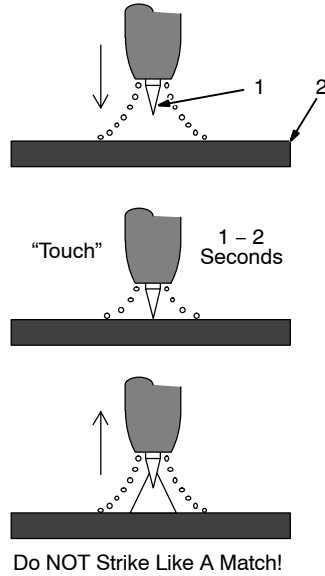

With Process Switch in the Lift-Arc TIG position, start an arc as follows:

- 1 TIG Electrode
- 2 Workpiece

Touch tungsten electrode to workpiece at weld start point, **hold electrode to workpiece for 1-2 seconds**, and slowly lift electrode. An arc will form when electrode is lifted.

Normal open-circuit voltage is not present before tungsten electrode touches workpiece; only a low sensing voltage is present between electrode and workpiece. The solid-state output contactor does not energize until after electrode is touching workpiece. This allows electrode to touch workpiece without overheating, sticking, or getting contaminated.

Ref. S-156 279

5-5. Stick Start Procedure

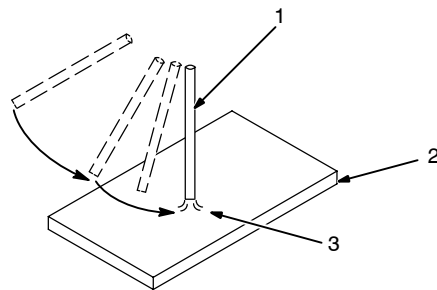

With Stick selected, start arc as follows:

- 1 Electrode
- 2 Workpiece
- 3 Arc

Drag electrode across workpiece like striking a match; lift electrode slightly after touching work. If arc goes out electrode was lifted to high. If electrode sticks to workpiece, use a quick twist to free it.

Low OCV Stick

The unit can be optionally configured for low open circuit voltage (OCV) operation. When the unit is configured for low OCV operation only a low sensing voltage (approximately 15 VDC) is present between the electrode and the workpiece prior to the electrode touching the workpiece. Consult a Factory Authorized Service Agent for information regarding how to configure the unit for low OCV stick welding operation.

SECTION 6 – MAINTENANCE & TROUBLESHOOTING

6-1. Routine Maintenance

		Disconnect power before maintaining.		<i>Maintain more often during severe conditions.</i>
3 Months				
		Replace Damaged Or Unreadable Labels		Repair Or Replace Cracked Cables
				Replace Cracked Torch Body
				Repair Or Replace Cracked Cables And Cords
				Clean And Tighten Weld Connections
6 Months				
Blow Out Inside				

6-2. Blowing Out Inside Of Unit

		Do not remove case when blowing out inside of unit.
		To blow out unit, direct airflow through front and back louvers as shown.
Ref. 803 691-C		

6-3. Voltmeter/Ammeter Help Displays

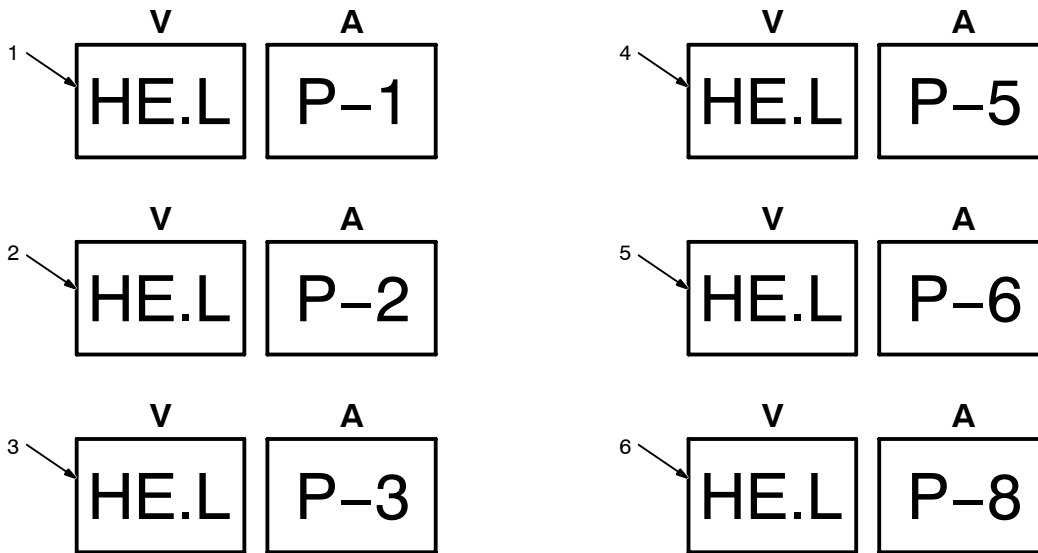

 All directions are in reference to the front of the unit. All circuitry referred to is located inside the unit.

1 Help 1 Display

Indicates a malfunction in the primary power circuit. If this display is shown, contact a Factory Authorized Service Agent.

2 Help 2 Display

Indicates a malfunction in the thermal protection circuitry. If this display is shown, contact a Factory Authorized Service Agent.

3 Help 3 Display

Indicates the left side of the unit has overheated. The unit has shut down to allow the fan to cool it (see Section 3-3). Operation will continue when the unit has cooled.

4 Help 5 Display

Indicates the right side of the unit has overheated. The unit has shut down to allow the fan to cool it (see Section 3-3). Operation will continue when the unit has cooled.

5 Help 6 Display

Indicates operation at maximum input current. The unit has a maximum allowable input

current limit. As the line voltage decreases, the required input current increases. If the line voltage is too low, the output power is limited by the input current. When this limit is reached, the unit automatically reduces output power to continue operation. If this display is shown, have a qualified electrician check the input voltage.

6 Help 8 Display

Indicates a malfunction in the secondary power circuit of the unit. If this display is shown, contact a Factory Authorized Service Agent.

6-4. Troubleshooting

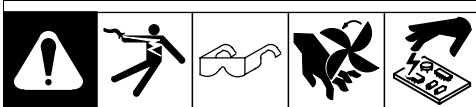

Trouble	Remedy
No weld output; unit completely inoperative.	Place line disconnect switch in On position (see Sections 4-3 and 4-4).
	Check and replace line fuse(s), if necessary, or reset circuit breaker (see Sections 4-3 and 4-4).
	Check for proper input power connections (see Sections 4-3 and 4-4).
No weld output; meter display On.	Input voltage outside acceptable range of variation (see Section 4-5).
	Check, repair, or replace remote control.
	Unit overheated. Allow unit to cool with fan On (see Section 3-3).
Erratic or improper weld output.	Use proper size and type of weld cable (see Section 4-6).
	Clean and tighten all weld connections.
	Check for correct polarity.
No 115 volts ac output at optional duplex receptacle or Remote 14 receptacle.	Reset circuit breaker CB1.
No 24 volts ac output at Remote 14 receptacle.	Reset circuit breaker CB2.

SECTION 7 – ELECTRICAL DIAGRAM

⚠ WARNING  ELECTRIC SHOCK HAZARD	<ul style="list-style-type: none"> • Do not touch live electrical parts. • Disconnect input power or stop engine before servicing. • Do not operate with covers removed. • Have only qualified persons install, use, or service this unit.
---	--

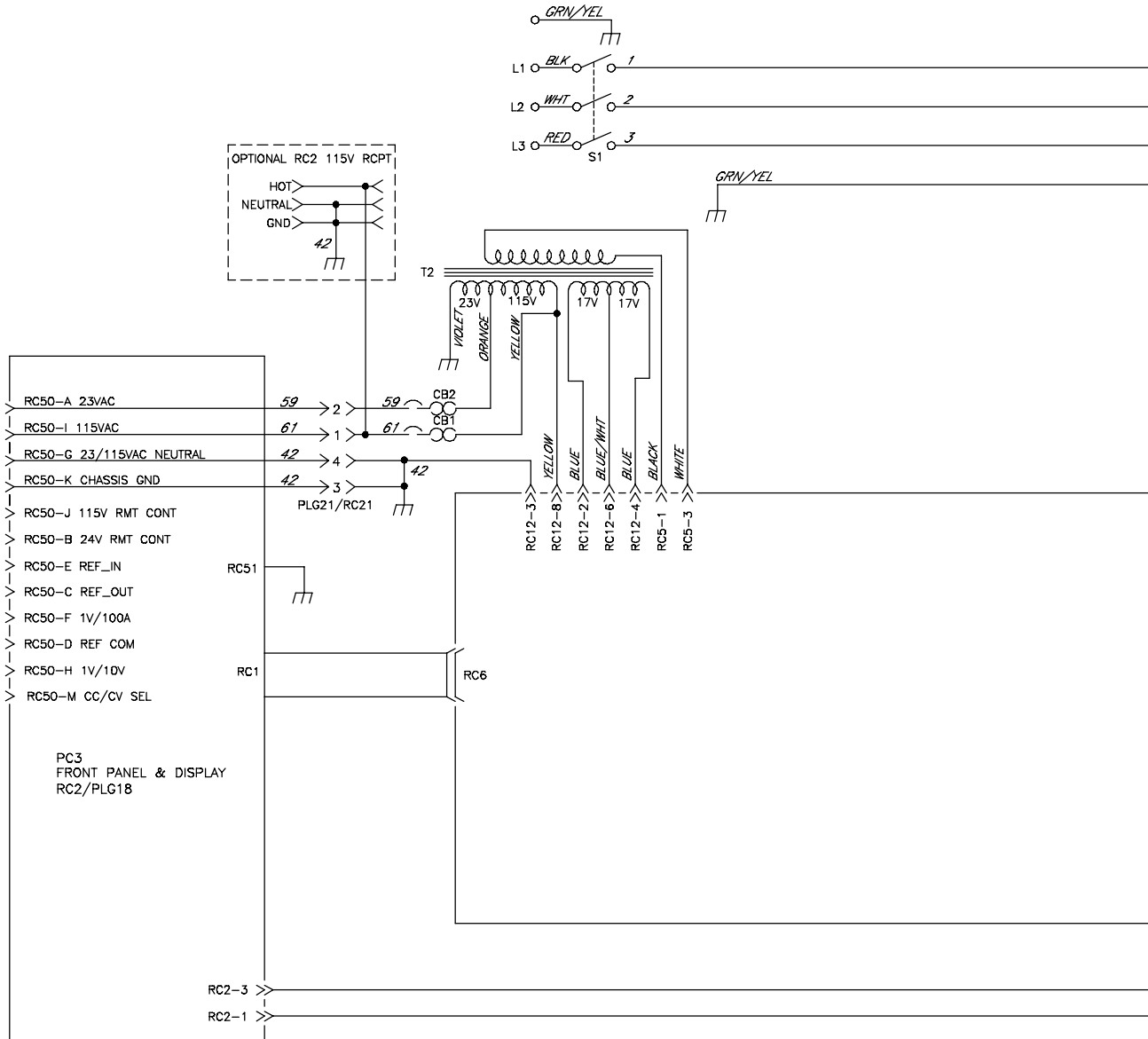
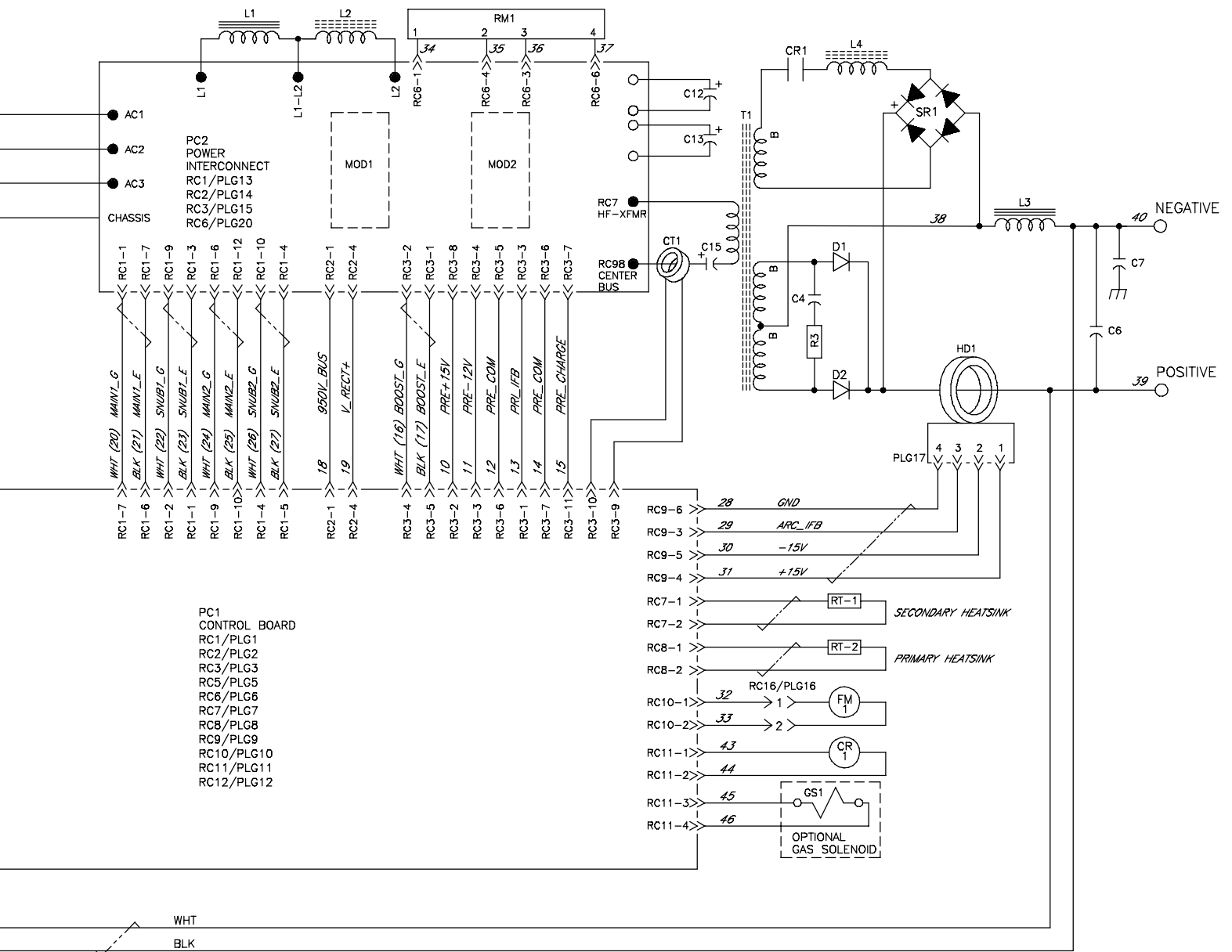
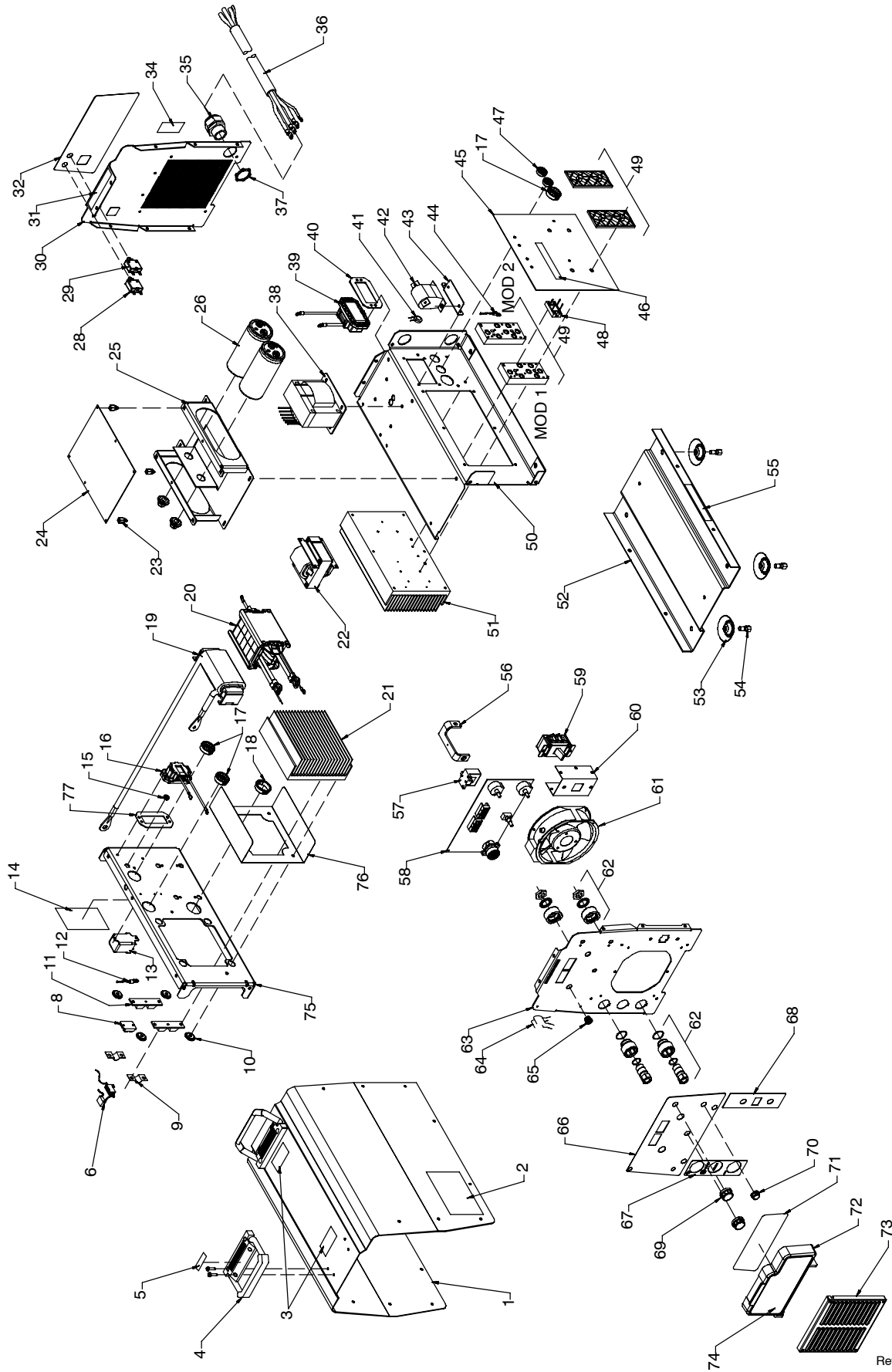

Figure 7-1. Circuit Diagram



SECTION 8 - PARTS LIST



Ref. 803 690-H

Figure 8-1. Parts Assembly

Item No.	Dia. Mkgs.	Part No.	Description	Quantity
----------	------------	----------	-------------	----------

Figure 8-1. Parts Assembly

1		229 541	Wrapper (Includes Insulators and Safety Labels)	1
		175 256	Insulator, Side Rh (Not Shown)	1
		178 551	Insulator, Side (Not Shown)	1
2		134 327	Label, Warning General Precautionary Static & Wire Feed	1
3		138 442	Label, Caution Falling Equip Can Cause Injury	2
4		195 585	Handle, Rubberized Carrying	2
5		135 483	Label, Important Remove These Two Handle Screws	2
6	R3/C4	233 052	Resistor/Capacitor	1
7		Deleted		
8	SR1	201 530	Kit, Diode Fast Recovery Bridge	1
9		199 840	Bus Bar, Diode	2
10		196 355	Insulator, Screw	4
11	D1,D2	201 531	Kit, Diode Power Module	2
12	RT1	199 798	Thermistor, NTC 30K Ohm @ 25 Deg C 18In Lead	1
13	CR1	198 549	Relay, Encl 24VDC Spst 35a/300VAC 4pin Flange Mtg	1
14		227 127	Label, Warning Electric Shock/Exploding Parts	1
15		010 546	Bushing, Snap-In Nyl .375 Id X .500 Mtg Hole	1
16	L4	218 020	Inductor, Boost	1
17		179 276	Bushing, Snap-In Nyl 1.000 Id X 1.375 Mtg Hole Cent	3
18		170 647	Bushing, Snap-In Nyl 1.312 Id X 1.500 Mtg Hole	1
19	L3	212 150	Inductor, Output	1
20	T1	212 132	XFMR, HF Litz/Litz W/Boost	1
21		225 097	Heat Sink, Lh Rect	1
22	L1	212 091	Inductor, Input	1
23		083 147	Grommet, Scr No 8/10 Panel Hole .312 Sq .500 High	4
24	PC1	218 007	Circuit Card Assy, Control W/Program	1
24	PC1	◆223 656	Circuit Card Assy, Control/Aux Power W/Program	1
		216 113	Stand-Off Support, PC Card .187 Dia W/P&I .375	2
	PLG1	115 091	Housing Plug+Pins (Service Kit) RC1	1
	PLG2	201 665	Housing Plug+Pins (Service Kit) RC2	1
	PLG3	131 056	Housing Plug+Pins (Service Kit) RC3	1
	PLG5	131 204	Housing Plug+Pins (Service Kit) RC5	1
	PLG7	131 054	Housing Plug+Pins (Service Kit) RC7	1
	PLG8	131 054	Housing Plug+Pins (Service Kit) RC8	1
	PLG9	115 093	Housing Plug+Pins (Service Kit) RC9	1
	PLG10	115 094	Housing Plug+Pins (Service Kit) RC10	1
	PLG11	115 094	Housing Plug+Pins (Service Kit) RC11	1
	PLG12	115 092	Housing Plug+Pins (Service Kit) RC12	1
25		212 072	Bracket, Mtg Capacitor/Pc Board	1
26	C12,13	219 930	Kit, Capacitor Elclt Replacement (Includes)	1
		193 738	Capacitor, Elclt 1800 Uf 500 VDC Can 2.52 Dia	2
		217 040	Nut, Nylon M12 Thread Capacitor Mounting	2
	RC2	◆604 176	Rcpt, Str Dx Grd 2P3W 15A 125V *5-15R	1
28	CB2	083 432	Circuit Breaker, Man Reset 1P 10A 250VAC Frict	1
29	CB1	089 807	Circuit Breaker, Man Reset 1P 2.5A 250VAC Frict	1
29	CB1	◆083 432	Circuit Breaker, Man Reset 1P 10A 250VAC Frict	1
30		+212 071	Panel, Rear Standard	1
30		◆+212 202	Panel, Rear	1
31		126 026	Label, Warning Electric Shock Can Kill Significant	1
32			Nameplate, Rear (Order by Model and Serial Number)	1
32		◆	Nameplate, Rear Aux (Order by Model and Serial Number)	1
		◆175 282	Cover, Receptacle Weatherproof Duplex Rcpt	1
34		217 480	Label, Warning Incorrect Connections	1
35		215 980	Bushing, Strain Relief .709/.984 Id X1.375 Mtg Hole	1
36		219 487	Cable, Power 12 Ft 8Ga 4C (Non-Stripped End)	1

+When ordering a component originally displaying a precautionary label, the label should also be ordered.

◆Part of 115V Aux Power Option. (Not Available On French Units)

BE SURE TO PROVIDE MODEL AND SERIAL NUMBER WHEN ORDERING REPLACEMENT PARTS.

Item No.	Dia. Mkgs.	Part No.	Description	Quantity
37		234 126	Nut, Conduit 1.000 Npt Knurled	1
38	T2	211 109	XFMR, Control 665V 336Va Syn Aux Pwr	1
38	T2	◆211 968	XFMR, Control Toroidal 665 VAC Pri 1536 Va 60 Hz	1
		◆212 947	Plate, Mtg Toroid XFMR	1
39	L2	218 018	Inductor, Pre-Regulator	1
40		218 566	Gasket, Inductor Mounting	1
41	CT1	196 231	XMFR, Current Sensing 200/1	1
42	C15	196 143	Capacitor, Polyp Met Film 16. Uf 400 VAC 10%	1
43		216 117	Bracket, Mtg Capacitor Series	1
44	RT2	199 798	Thermistor, Ntc 30K Ohm @ 25 Deg C 18in Lead	1
45	PC2	225 442	Circuit Card Assy, Interconnect W/Label & Clips (Includes)	1
46		126 026	Label, Warning Electric Shock Can Kill Significant	1
		223 343	Clip, Wire Stdf .40-.50 Bndl .156Hole .031-.078Thk	2
	PLG13	130 203	Housing Plug+Pins (Service Kit) RC1	1
	PLG14	201 665	Housing Plug+Pins (Service Kit) RC2	1
	PLG15	115 092	Housing Plug+Pins (Service Kit) RC3	1
	PLG20	115 093	Housing Plug+Pins (Service Kit) RC6	1
47		153 403	Bushing, Snap-In Nyl .750 Id X 1.000 Mtg Hole Cent	2
48	RM1	205 751	Module, Power Resistor W/Plug	1
49		217 625	Kit, Input/Pre-Regulator And Inverter Module (Includes)	1
			MOD 1, SKiip 83 HEC	1
			MOD 2, SKiip 83 EC	1
50		212 206	Windtunnel, Rh	1
51		196 330	Heat Sink, Power Module	1
52		+175 132	Base	1
53		229 325	Foot, Mtg Unit	4
54		176 736	Screw, Mtg Foot	4
55		153 178	Label, Warning Exploding Parts Can Serious Injury	1
56		212 074	Bus Bar, Output	1
57	HD1	182 918	Transducer, Current 400A Module Supply V +/- 15V	1
58	PC3	218 008	Circuit Card Assy, Front Panel & Display W/Program	1
	PLG18	131 204	Housing Plug+Pins (Service Kit) RC2	1
	RC50	210 233	Rcpt, W/Pins (Service Kit)	1
	PLG21	212 088	Plug, W/Leads	1
	RC21	167 640	Housing Plug+Pins (Service Kit)	1
59	S1	231 191	Switch, Tgl 3Pst 50A 600VAC Scr Term Wide Tgl	1
60		176 226	Insulator, Switch Power	1
61	FM1	196 313	Fan, Muffin 115V 50/60Hz 3000 Rpm 6.378 Mtg Holes	1
	PLG16	131 054	Housing Plug+Pins (Service Kit)	1
	RC16	135 635	Housing Plug+Pins (Service Kit)	1
62		218 183	Rcpt Assy, Tw Lk Insul Fem (Tweco Type) (Fac-op) (Includes)	2
		209 473	Receptacle, Twist Lock Tweco Style (Female) Power	1
		185 712	Insulator, Bulkhead Front	1
		185 713	Insulator, Bulkhead Rear	1
		185 714	Washer, Tooth 22Mmid X 31.5Mmod 1.310-1Mmt Intern	1
		185 717	Nut, M20-1.5 1.00Hex .19H Brs Locking	1
		185 718	O-Ring, 0.989 Id X 0.070 H	1
		186 228	O-Ring, 0.739 Id X 0.070 H	1
63		212 070	Panel, Front Standard	1
64	C6,7	214 749	Capacitor Assy, W/Plug & Leads (Voltage Feedback)	1
65		216 112	Fastener, Panel Receptacle Quick Access	2
66			Nameplate (Order by Model and Serial Number)	1
67			Nameplate, Connection (Order by Model and Serial Number)	1
68			Nameplate, Power (Order by Model and Serial Number)	1
69		174 991	Knob, Pointer 1.250 Dia X .250 Id W/Spring Clip-.21	2

+When ordering a component originally displaying a precautionary label, the label should also be ordered.

◆Part of 115V Aux Power Option. (Not Available On French Units)

BE SURE TO PROVIDE MODEL AND SERIAL NUMBER WHEN ORDERING REPLACEMENT PARTS.

Item No.	Dia. Mkgs.	Part No.	Description	Quantity
Figure 8-1. Parts Assembly (Continued)				
... 70		174 992	.. Knob, Pointer .840 Dia X .250 Id W/Spring Clip-.21	1
... 71		212 949	.. Label, Process	1
... 72		218 041	.. Door, W/Quick Access Ball Fasteners	1
... 73		175 138	.. Box, Louver	1
... 74			Label, (Order by Model and Serial Number)	1
... 75		+212 207	.. Windtunnel, Lh	1
... 76		211 503	.. Insulator, Heat Sink	1
... 77		227 746	.. Gasket, Inductor Mounting	1

+When ordering a component originally displaying a precautionary label, the label should also be ordered.

◆Part of 115V Aux Power Option. (Not Available On French Units)

BE SURE TO PROVIDE MODEL AND SERIAL NUMBER WHEN ORDERING REPLACEMENT PARTS.

Notes

**SOCKET/WRENCH SELECTION TABLE
(U.S. STANDARD)**

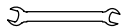

**SOCKET/WRENCH SELECTION TABLE
(METRIC)**

Specifications		Socket or Wrench Size			Specifications		Socket or Wrench Size	
Bolt Diameter	Decimal Equivalent	Bolt	Nut		Bolt Diameter	U.S. Decimal Equivalent	Bolt	Nut
1/4 in	.250 in	3/8 in	7/16 in		6 mm	.2362 in	10 mm	10 mm
5/16 in	.3125 in	1/2 in	9/16 in		8 mm	.3150 in	14 mm	14 mm
3/8 in	.375 in	9/16 in	5/8 in		10 mm	.3937 in	17 mm	17 mm
7/16 in	.4375 in	5/8 in	3/4 in		12 mm	.4724 in	19 mm	19 mm
1/2 in	.500 in	3/4 in	13/16 in		14 mm	.5512 in	22 mm	22 mm
9/16 in	.5625 in	7/8 in	7/8 in		16 mm	.6299 in	24 mm	24 mm
5/8 in	.625 in	15/16 in	1 in		18 mm	.7087 in	27 mm	27 mm
3/4 in	.750 in	1-1/8 in	1-1/8 in		22 mm	.8661 in	32 mm	32 mm
7/8 in	.875 in	1-5/16 in	1-5/16 in		24 mm	.9449 in	36 mm	36 mm
1 in	1.000 in	1-1/2 in	1-1/2 in					

Warranty

Effective January 1, 2007
(Equipment with a serial number preface of "LH" or newer)

This limited warranty supersedes all previous manufacturers warranties and is exclusive with no other guarantees or warranties expressed or implied.

LIMITED WARRANTY – Subject to the terms and conditions below, warrants to its original retail purchaser that new equipment sold after the effective date of this limited warranty is free of defects in material and workmanship at the time it is shipped from factory. THIS WARRANTY IS EXPRESSLY IN LIEU OF ALL OTHER WARRANTIES, EXPRESS OR IMPLIED, INCLUDING THE WARRANTIES OF MERCHANTABILITY AND FITNESS.

Within the warranty periods listed below, manufacturer will repair or replace any warranted parts or components that fail due to such defects in material or workmanship. Manufacturer must be notified in writing within thirty (30) days of such defect or failure, at which time manufacturer will provide instructions on the warranty claim procedures to be followed.

Manufacturer shall honor warranty claims on warranted equipment listed below in the event of such a failure within the warranty time periods. All warranty time periods start on the delivery date of the equipment to the original end-user purchaser, and not to exceed one year after the equipment is shipped to the distributor.

1. 5 Years Parts — 3 Years Labor
 - * Original main power rectifiers
2. 3 Years — Parts and Labor
 - * Transformer/Rectifier Power Sources
 - * Plasma Arc Cutting Power Sources
 - * Process Controllers
 - * Semi-Automatic and Automatic Wire Feeders
 - * Inverter Power Sources (Unless Otherwise Stated)
 - * Water Coolant Systems (Integrated)
 - * Engine Driven Welding Generators
(NOTE: Engines are warranted separately by the engine manufacturer.)
3. 1 Year — Parts and Labor Unless Specified
 - * Motor Driven Guns (w/exception of Spoolmate Spoolguns)
 - * Positioners and Controllers
 - * Automatic Motion Devices
 - * RFCS Foot Controls
 - * Induction Heating Power Sources, Coolers, and Electronic Controls/Recorders
 - * Water Coolant Systems (Non-Integrated)
 - * Flowgauge and Flowmeter Regulators (No Labor)
 - * HF Units
 - * Grids
 - * Spot Welders
 - * Load Banks
 - * Arc Stud Power Sources & Arc Stud Guns
 - * Racks
 - * Running Gear/Trailers
 - * Plasma Cutting Torches (except APT & SAF models)
 - * Field Options
(NOTE: Field options are covered for the remaining warranty period of the product they are installed in, or for a minimum of one year — whichever is greater.)
 - * Bernard-Branded Mig Guns (No Labor)
 - * Weldcraft-Branded TIG Torches (No Labor)
 - * Subarc Wire Drive Assemblies
4. 6 Months — Batteries
5. 90 Days — Parts and Labor
 - * MIG Guns/TIG Torches and Subarc (SAW) Guns

- * Induction Heating Coils and Blankets, Cables, and Non-Electronic Controls
- * APT & SAF Plasma Cutting Torches
- * Remote Controls
- * Accessory Kits
- * Replacement Parts (No Labor)
- * Spoolmate Spoolguns
- * Canvas Covers

Limited Warranty shall not apply to:

1. **Consumable components; such as contact tips, cutting nozzles, contactors, relays, brushes, slip rings, or parts that fail due to normal wear.**
2. Items furnished by manufacturer, but manufactured by others, such as engines or trade accessories. These items are covered by the manufacturer's warranty, if any.
3. Equipment that has been modified by any party other than manufacturer, or equipment that has been improperly installed, improperly operated or misused based upon industry standards, or equipment which has not had reasonable and necessary maintenance, or equipment which has been used for operation outside of the specifications for the equipment.

MANUFACTURER'S PRODUCTS ARE INTENDED FOR PURCHASE AND USE BY COMMERCIAL/INDUSTRIAL USERS AND PERSONS TRAINED AND EXPERIENCED IN THE USE AND MAINTENANCE OF WELDING EQUIPMENT.

In the event of a warranty claim covered by this warranty, the exclusive remedies shall be, at manufacturer's option: (1) repair; or (2) replacement; or, where authorized in writing by manufacturer in appropriate cases, (3) the reasonable cost of repair or replacement at an authorized service station; or (4) payment of or credit for the purchase price (less reasonable depreciation based upon actual use) upon return of the goods at customer's risk and expense. Manufacturer's option of repair or replacement will be F.O.B., Factory at Appleton, Wisconsin, or F.O.B. at an authorized service facility as determined by manufacturer. Therefore no compensation or reimbursement for transportation costs of any kind will be allowed.

TO THE EXTENT PERMITTED BY LAW, THE REMEDIES PROVIDED HEREIN ARE THE SOLE AND EXCLUSIVE REMEDIES. IN NO EVENT SHALL MANUFACTURER BE LIABLE FOR DIRECT, INDIRECT, SPECIAL, INCIDENTAL OR CONSEQUENTIAL DAMAGES (INCLUDING LOSS OF PROFIT), WHETHER BASED ON CONTRACT, TORT OR ANY OTHER LEGAL THEORY.

ANY EXPRESS WARRANTY NOT PROVIDED HEREIN AND ANY IMPLIED WARRANTY, GUARANTY OR REPRESENTATION AS TO PERFORMANCE, AND ANY REMEDY FOR BREACH OF CONTRACT TORT OR ANY OTHER LEGAL THEORY WHICH, BUT FOR THIS PROVISION, MIGHT ARISE BY IMPLICATION, OPERATION OF LAW, CUSTOM OF TRADE OR COURSE OF DEALING, INCLUDING ANY IMPLIED WARRANTY OF MERCHANTABILITY OR FITNESS FOR PARTICULAR PURPOSE, WITH RESPECT TO ANY AND ALL EQUIPMENT FURNISHED BY MANUFACTURER IS EXCLUDED AND DISCLAIMED BY MANUFACTURER.

Some states in the U.S.A. do not allow limitations of how long an implied warranty lasts, or the exclusion of incidental, indirect, special or consequential damages, so the above limitation or exclusion may not apply to you. This warranty provides specific legal rights, and other rights may be available, but may vary from state to state.

In Canada, legislation in some provinces provides for certain additional warranties or remedies other than as stated herein, and to the extent that they may not be waived, the limitations and exclusions set out above may not apply. This Limited Warranty provides specific legal rights, and other rights may be available, but may vary from province to province.



Owner's Record

Please complete and retain with your personal records.

Model Name

Serial/Style Number

Purchase Date

(Date which equipment was delivered to original customer.)

Distributor

Address

City

State

Zip

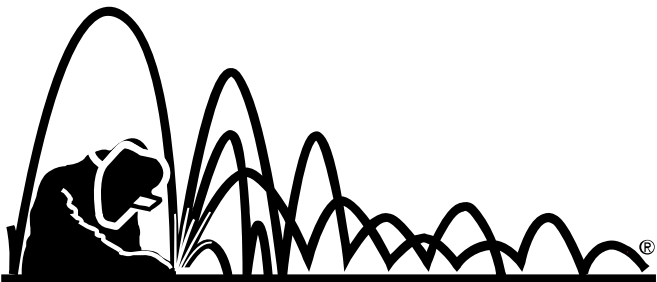

RED-D-ARC

Welderrentals

1-800-245-3660

www.red-d-arc.com

Contact the Delivering Carrier for:

File a claim for loss or damage during shipment.

For assistance in filing or settling claims, contact your distributor and/or equipment manufacturer's Transportation Department.